



**THE DATASHEET OF
IXTY44N10T**



TrenchMV™ Power MOSFET

IXTP44N10T IXTY44N10T

$$V_{DSS} = 100 \text{ V}$$

$$I_{D25} = 44 \text{ A}$$

$$R_{DS(on)} \leq 30 \text{ m}\Omega$$

N-Channel Enhancement Mode
Avalanche Rated

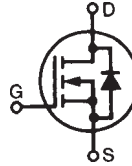

TO-220 (IXTP)

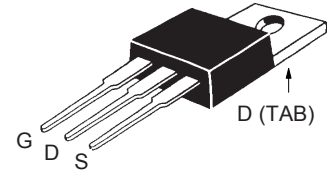

TO-252 AA (IXTY)

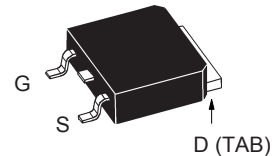

G = Gate
S = Source
D = Drain
TAB = Drain

| Symbol | Test Conditions | Maximum Ratings | |
|------------|--|-----------------|------------------|
| V_{DSS} | $T_J = 25^\circ\text{C}$ to 175°C | 100 | V |
| V_{DGR} | $T_J = 25^\circ\text{C}$ to 175°C ; $R_{GS} = 1 \text{ M}\Omega$ | 100 | V |
| V_{GSM} | Transient | ± 30 | V |
| I_{D25} | $T_C = 25^\circ\text{C}$ | 44 | A |
| I_L | Package Current Limit, RMS TO-252A | 25 | A |
| I_{DM} | $T_C = 25^\circ\text{C}$, pulse width limited by T_{JM} | 140 | A |
| I_{AR} | $T_C = 25^\circ\text{C}$ | 10 | A |
| E_{AS} | $T_C = 25^\circ\text{C}$ | 250 | mJ |
| dv/dt | $I_S \leq I_{DM}$, $di/dt \leq 100 \text{ A}/\mu\text{s}$, $V_{DD} \leq V_{DSS}$ $T_J \leq 175^\circ\text{C}$, $R_G = 18 \Omega$ | 3 | V/ns |
| P_D | $T_C = 25^\circ\text{C}$ | 130 | W |
| T_J | | -55 ... +175 | $^\circ\text{C}$ |
| T_{JM} | | 175 | $^\circ\text{C}$ |
| T_{stg} | | -40 ... +175 | $^\circ\text{C}$ |
| T_L | 1.6 mm (0.062 in.) from case for 10 s | 300 | $^\circ\text{C}$ |
| T_{SOLD} | Plastic body for 10 seconds | 260 | $^\circ\text{C}$ |
| M_d | Mounting torque (TO-220) | 1.13 / 10 | Nm/lb.in. |
| Weight | TO-220 | 3 | g |
| | TO-252 | 0.8 | g |

Features

- Ultra-low On Resistance
- Unclamped Inductive Switching (UIS) rated
- Low package inductance
 - easy to drive and to protect
- 175°C Operating Temperature

Advantages

- Easy to mount
- Space savings
- High power density

Applications

- Automotive
 - Motor Drives
 - 42V Power Bus
 - ABS Systems
- DC/DC Converters and Off-line UPS
- Primary Switch for 24V and 48V Systems
- Distributed Power Architectures and VRMs
- Electronic Valve Train Systems
- High Current Switching Applications
- High Voltage Synchronous Rectifier

| Symbol | Test Conditions ($T_J = 25^\circ\text{C}$ unless otherwise specified) | Characteristic Values | | |
|--------------|--|-----------------------|------|----------------------|
| | | Min. | Typ. | Max. |
| BV_{DSS} | $V_{GS} = 0 \text{ V}$, $I_D = 250 \mu\text{A}$ | 85 | | V |
| $V_{GS(th)}$ | $V_{DS} = V_{GS}$, $I_D = 25 \mu\text{A}$ | 2.5 | | V |
| I_{GSS} | $V_{GS} = \pm 20 \text{ V}$, $V_{DS} = 0 \text{ V}$ | | | $\pm 100 \text{ nA}$ |
| I_{DSS} | $V_{DS} = V_{DSS}$ | | | 1 μA |
| | $V_{GS} = 0 \text{ V}$ $T_J = 150^\circ\text{C}$ | | | 100 μA |
| $R_{DS(on)}$ | $V_{GS} = 10 \text{ V}$, $I_D = 22 \text{ A}$, Notes 1, 2 | 22 | 30 | m Ω |

| Symbol | Test Conditions ($T_J = 25^\circ\text{C}$ unless otherwise specified) | Characteristic Values | | |
|--------------|---|-----------------------|------|------------------------|
| | | Min. | Typ. | Max. |
| g_{fs} | $V_{DS} = 10\text{ V}; I_D = 0.5 I_{D25}$, Note 1 | 13 | 21 | S |
| C_{iss} | | | 1262 | pF |
| C_{oss} | $V_{GS} = 0\text{ V}, V_{DS} = 25\text{ V}, f = 1\text{ MHz}$ | | 190 | pF |
| C_{rss} | | | 43 | pF |
| $t_{d(on)}$ | Resistive Switching Times | | 21 | ns |
| t_r | $V_{GS} = 10\text{ V}, V_{DS} = 0.5 V_{DSS}, I_D = 10\text{ A}$ | | 47 | ns |
| $t_{d(off)}$ | $R_G = 18\ \Omega$ (External) | | 36 | ns |
| t_f | | | 32 | ns |
| $Q_{g(on)}$ | | | 33 | nC |
| Q_{gs} | $V_{GS} = 10\text{ V}, V_{DS} = 0.5 V_{DSS}, I_D = 10\text{ A}$ | | 10 | nC |
| Q_{gd} | | | 11 | nC |
| R_{thJC} | | | | 1.15°C/W |
| R_{thCS} | TO-220 | 0.5 | | $^\circ\text{C/W}$ |

Source-Drain Diode

| Symbol | Test Conditions ($T_J = 25^\circ\text{C}$ unless otherwise specified) | Characteristic Values | | |
|----------|--|-----------------------|------|-------|
| | | Min. | Typ. | Max. |
| I_s | $V_{GS} = 0\text{ V}$ | | | 44 A |
| I_{SM} | Repetitive | | | 140 A |
| V_{SD} | $I_F = 25\text{ A}, V_{GS} = 0\text{ V}$, Note 1 | | | 1.1 V |
| t_{rr} | $I_F = 25\text{ A}, -di/dt = 100\text{ A}/\mu\text{s}$ $V_R = 50\text{ V}, V_{GS} = 0\text{ V}$ | | 100 | ns |

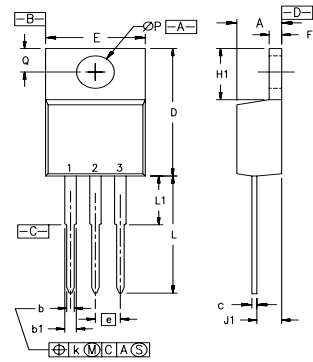
TO-220 (IXTP) Outline

Pins: 1 - Gate 2 - Drain
3 - Source 4, TAB - Drain

| SYM | INCHES | | MILLIMETERS | |
|-----|----------|------|-------------|-------|
| | MIN | MAX | MIN | MAX |
| A | .170 | .190 | 4.32 | 4.83 |
| b | .025 | .040 | 0.64 | 1.02 |
| b1 | .045 | .065 | 1.15 | 1.65 |
| c | .014 | .022 | 0.35 | 0.56 |
| D | .580 | .630 | 14.73 | 16.00 |
| E | .390 | .420 | 9.91 | 10.66 |
| e | .100 BSC | | 2.54 BSC | |
| F | .045 | .055 | 1.14 | 1.40 |
| H1 | .230 | .270 | 5.85 | 6.85 |
| J1 | .090 | .110 | 2.29 | 2.79 |
| k | 0 | .015 | 0 | 0.38 |
| L | .500 | .550 | 12.70 | 13.97 |
| L1 | .110 | .230 | 2.79 | 5.84 |
| ØP | .139 | .161 | 3.53 | 4.08 |
| Q | .100 | .125 | 2.54 | 3.18 |

Notes:

- Pulse test: $t \leq 300\ \mu\text{s}$, duty cycle $d \leq 2\%$;
- On through-hole packages, $R_{DS(on)}$ Kelvin test contact location must be 5 mm or less from the package body.

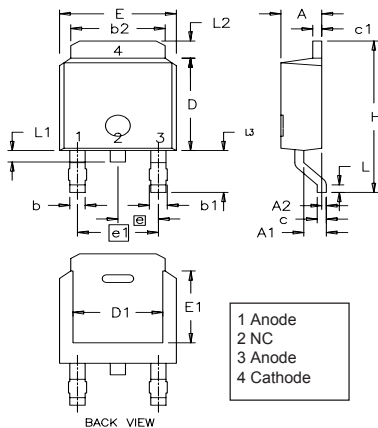
TO-252 (IXTY) Outline

1 Anode
2 NC
3 Anode
4 Cathode

| Dim. | Millimeter | | Inches | |
|------|------------|-------|-----------|-------|
| | Min. | Max. | Min. | Max. |
| A | 2.19 | 2.38 | 0.086 | 0.094 |
| A1 | 0.89 | 1.14 | 0.035 | 0.045 |
| A2 | 0 | 0.13 | 0 | 0.005 |
| b | 0.64 | 0.89 | 0.025 | 0.035 |
| b1 | 0.76 | 1.14 | 0.030 | 0.045 |
| b2 | 5.21 | 5.46 | 0.205 | 0.215 |
| c | 0.46 | 0.58 | 0.018 | 0.023 |
| c1 | 0.46 | 0.58 | 0.018 | 0.023 |
| D | 5.97 | 6.22 | 0.235 | 0.245 |
| D1 | 4.32 | 5.21 | 0.170 | 0.205 |
| E | 6.35 | 6.73 | 0.250 | 0.265 |
| E1 | 4.32 | 5.21 | 0.170 | 0.205 |
| e | 2.28 BSC | | 0.090 BSC | |
| e1 | 4.57 BSC | | 0.180 BSC | |
| H | 9.40 | 10.42 | 0.370 | 0.410 |
| L | 0.51 | 1.02 | 0.020 | 0.040 |
| L1 | 0.64 | 1.02 | 0.025 | 0.040 |
| L2 | 0.89 | 1.27 | 0.035 | 0.050 |
| L3 | 2.54 | 2.92 | 0.100 | 0.115 |

PRELIMINARY TECHNICAL INFORMATION

The product presented herein is under development. The Technical Specifications offered are derived from data gathered during objective characterizations of preliminary engineering lots; but also may yet contain some information supplied during a pre-production design evaluation. IXYS reserves the right to change limits, test conditions, and dimensions without notice.

IXYS reserves the right to change limits, test conditions, and dimensions.

IXYS MOSFETs and IGBTs are covered by 4,835,592 4,931,844 5,049,961 5,237,481 6,162,665 6,404,065 B1 6,683,344 6,727,585 7,005,734 B2
 one or more of the following U.S. patents: 4,850,072 5,017,508 5,063,307 5,381,025 6,259,123 B1 6,534,343 6,710,405B2 6,759,692 7,063,975 B2
 4,881,106 5,034,796 5,187,117 5,486,715 6,306,728 B1 6,583,505 6,710,463 6771478 B2 7,071,537

**Fig. 1. Output Characteristics
@ 25°C**

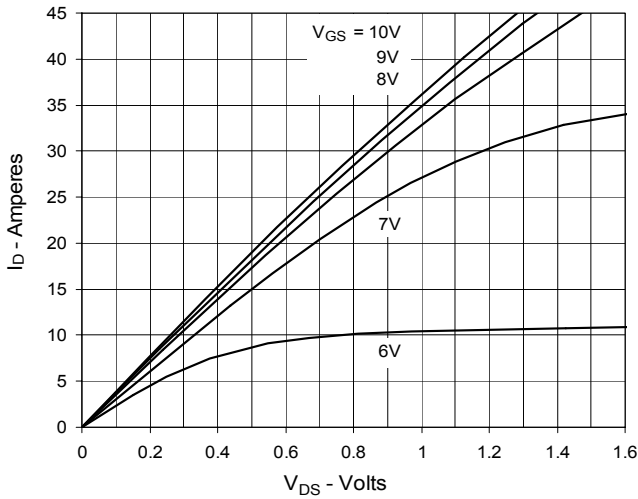

**Fig. 2. Extended Output Characteristics
@ 25°C**

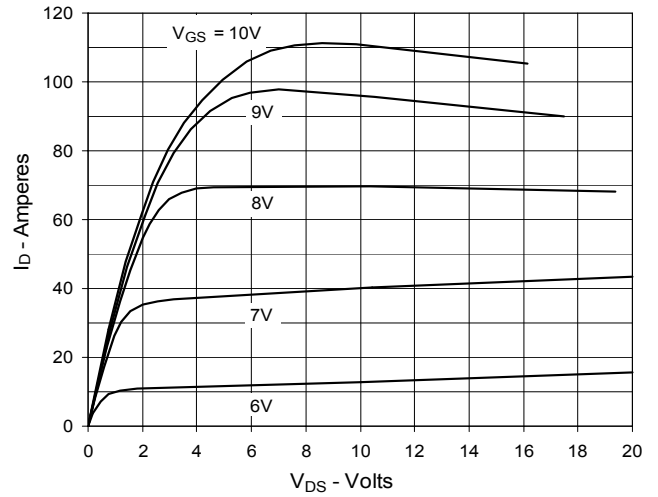

**Fig. 3. Output Characteristics
@ 150°C**

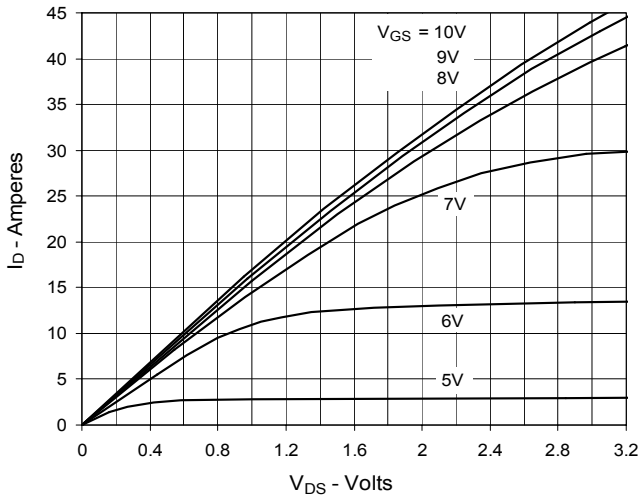

**Fig. 4. $R_{DS(on)}$ Normalized to $I_D = 22A$ Value
vs. Junction Temperature**

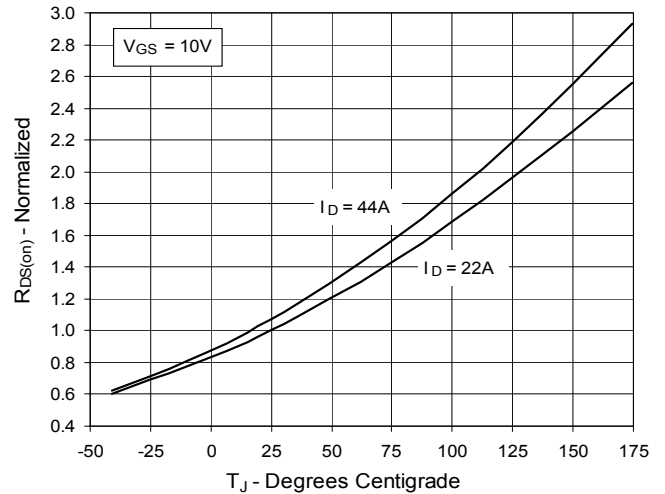

**Fig. 5. $R_{DS(on)}$ Normalized to $I_D = 22A$ Value
vs. Drain Current**

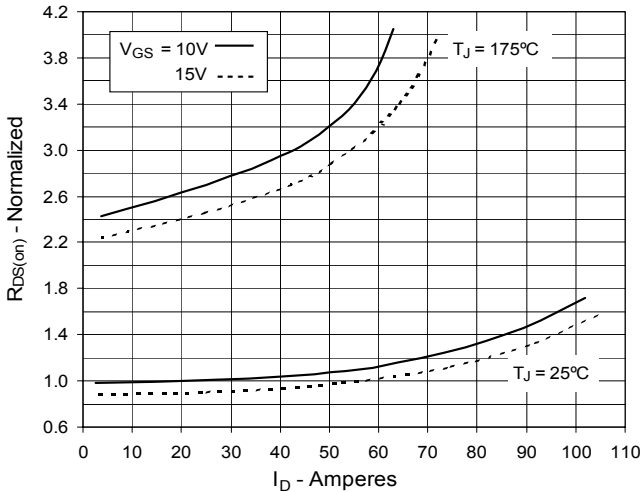

Fig. 6. Drain Current vs. Case Temperature

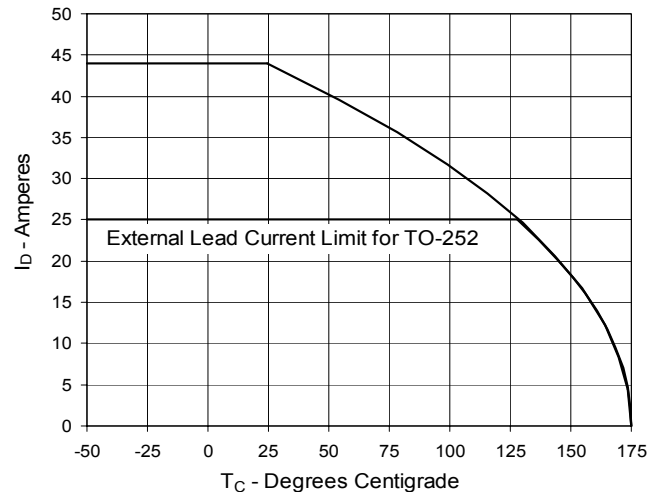

Fig. 7. Input Admittance

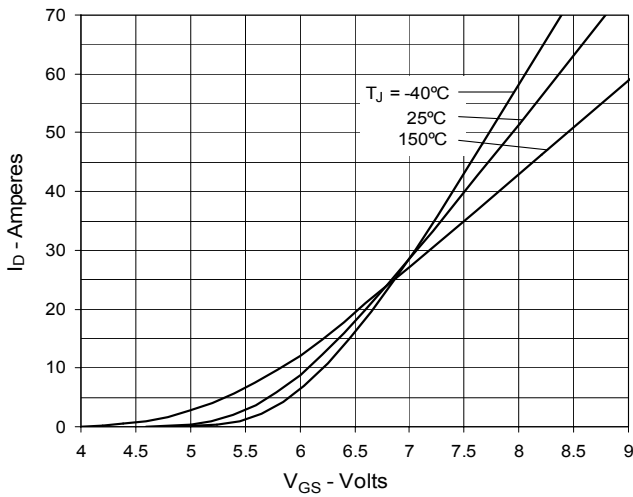

Fig. 8. Transconductance

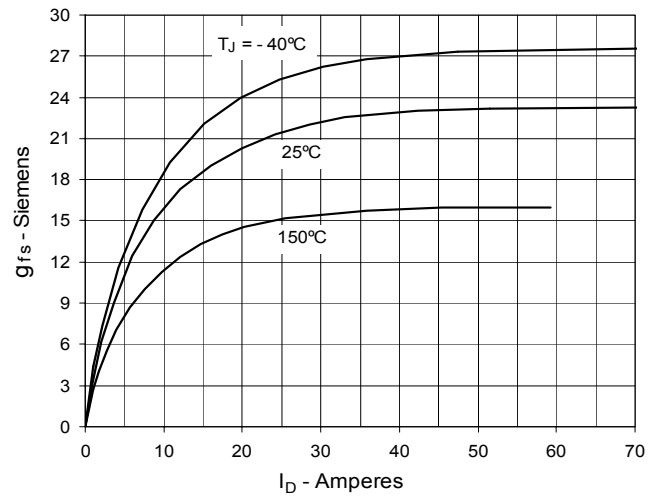

Fig. 9. Forward Voltage Drop of Intrinsic Diode

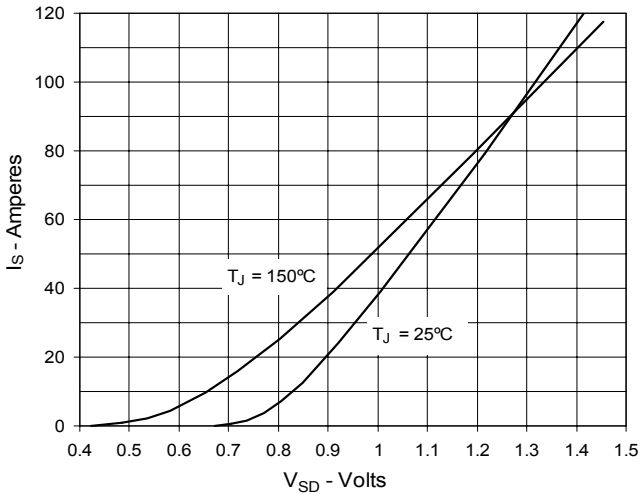

Fig. 10. Gate Charge

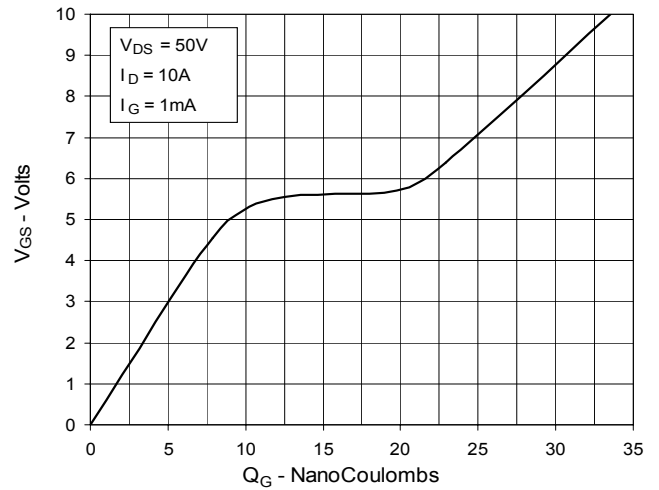

Fig. 11. Capacitance

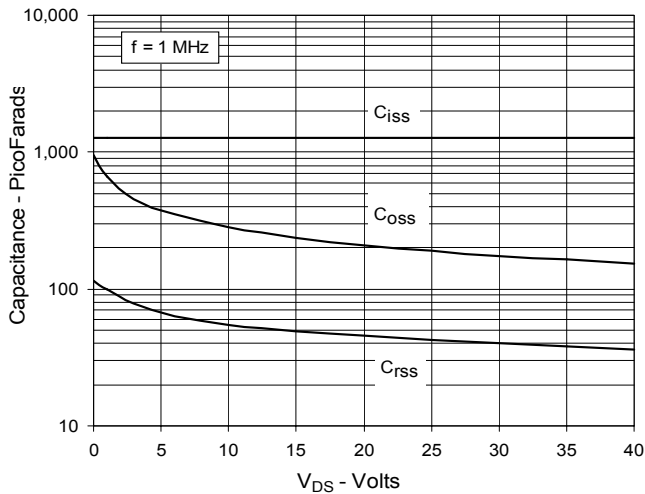
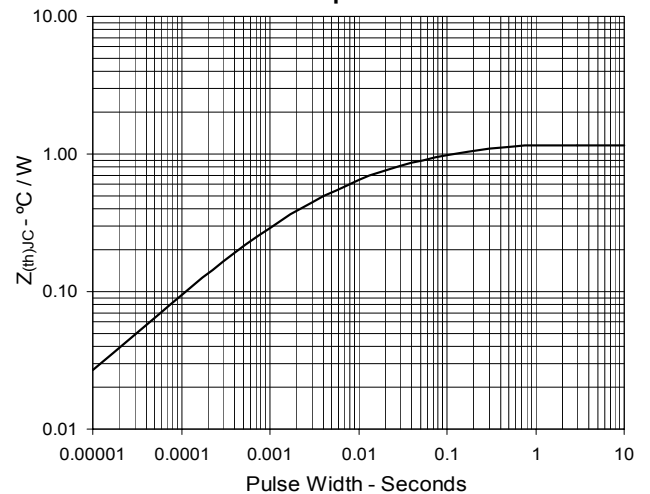
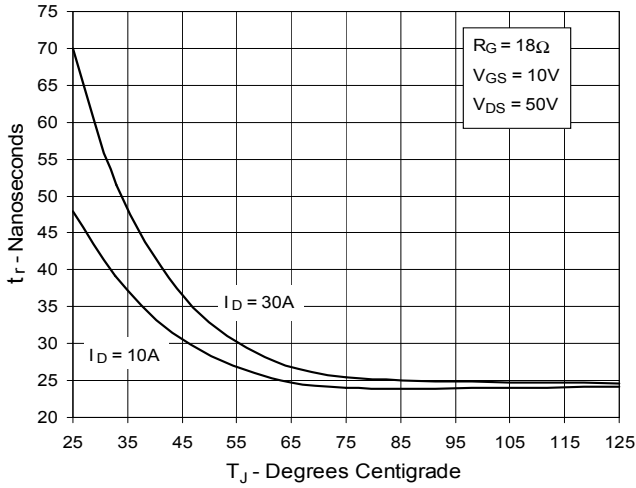

Fig. 12. Maximum Transient Thermal Impedance



**Fig. 13. Resistive Turn-on
Rise Time vs. Junction Temperature**



**Fig. 14. Resistive Turn-on
Rise Time vs. Drain Current**

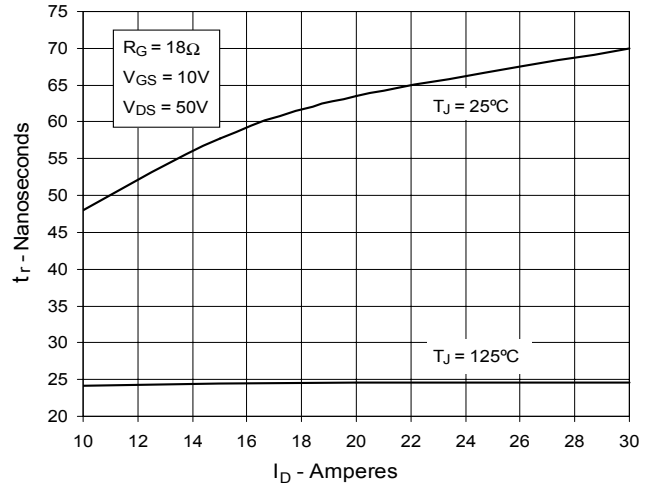

**Fig. 15. Resistive Turn-on
Switching Times vs. Gate Resistance**

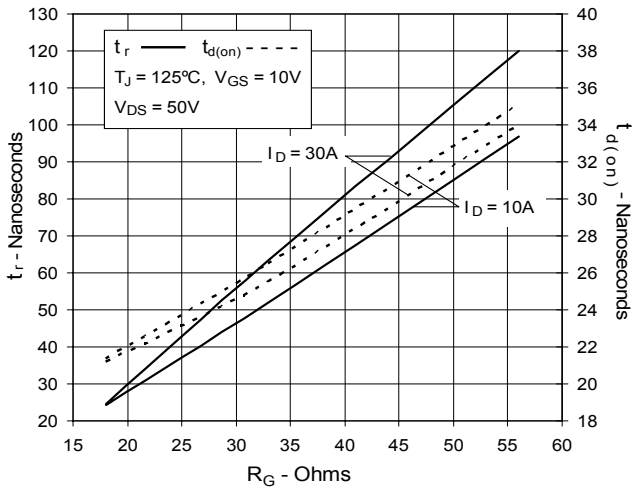

**Fig. 16. Resistive Turn-off
Switching Times vs. Junction Temperature**

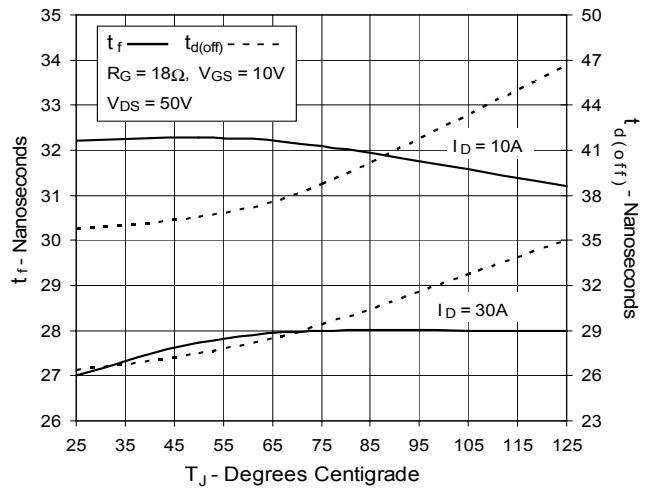

**Fig. 17. Resistive Turn-off
Switching Times vs. Drain Current**

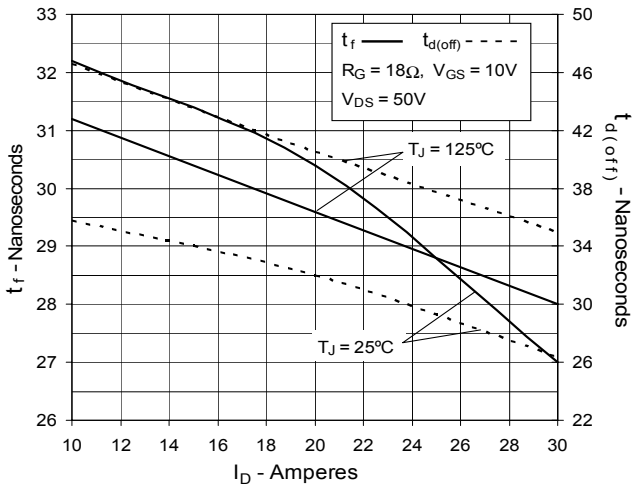

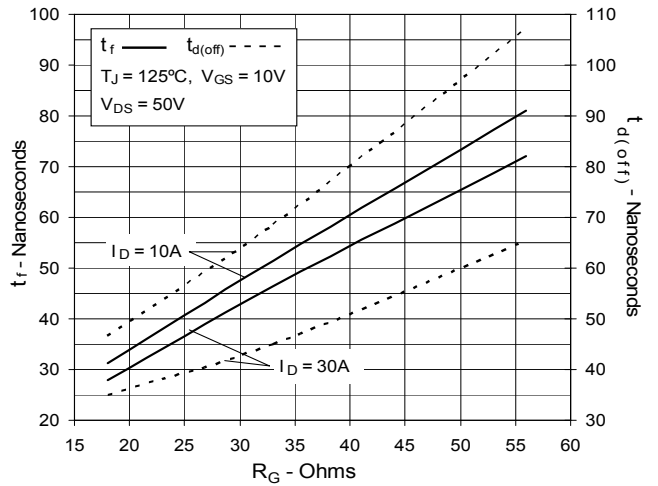

**Fig. 18. Resistive Turn-off
Switching Times vs. Gate Resistance**









Looking for pricing, stock, or lifecycle information?

Click below to explore more details on WIN SOURCE:

-  [View IXTY44N10T on WIN SOURCE](#)
-  [IXYS Information](#)

Optimize Your Supply Chain with WIN SOURCE Solutions

-  Global Sourcing Solution
-  Obsolete Management
-  Cost Control Management
-  Shortage Management
-  Alternative Solution
-  Excess Inventory Management