

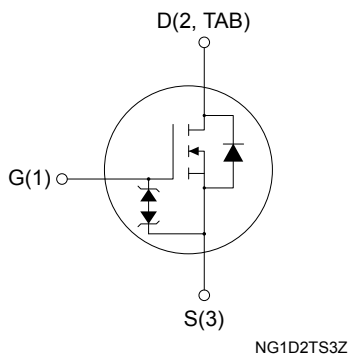

THE DATASHEET OF STD5N60M2

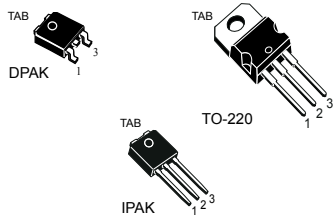

N-channel 600 V, 1.3 Ω typ., 3.5 A, MDmesh™ M2 Power MOSFETs in DPAK, TO-220 and IPAK packages



Features

Order code	$V_{DS@T_{Jmax}}$	$R_{DS(on) max.}$	I_D
STD5N60M2	650 V	1.4 Ω	3.5 A
STP5N60M2			
STU5N60M2			

- Extremely low gate charge
- Excellent output capacitance (C_{OSS}) profile
- 100% avalanche tested
- Zener-protected

Applications

- Switching applications

Description

These devices are N-channel Power MOSFETs developed using the MDmesh™ M2 technology. Thanks to their strip layout and improved vertical structure, these devices exhibit low on-resistance and optimized switching characteristics, rendering them suitable for the most demanding high-efficiency converters.

Product status links

[STD5N60M2](#)
[STP5N60M2](#)
[STU5N60M2](#)

1 Electrical ratings

Table 1. Absolute maximum ratings

Symbol	Parameter	Value	Unit
V_{GS}	Gate-source voltage	± 25	V
I_D	Drain current (continuous) at $T_C = 25\text{ }^\circ\text{C}$	3.5	A
	Drain current (continuous) at $T_C = 100\text{ }^\circ\text{C}$	2.2	
$I_{DM}^{(1)}$	Drain current (pulsed)	14	A
P_{TOT}	Total dissipation at $T_C = 25\text{ }^\circ\text{C}$	45	W
$dv/dt^{(2)}$	Peak diode recovery voltage slope	15	V/ns
$dv/dt^{(3)}$	MOSFET dv/dt ruggedness	50	
T_{stg}	Storage temperature range	-55 to 150	$^\circ\text{C}$
T_j	Operating junction temperature range		

1. Pulse width limited by safe operating area.
2. $I_{SD} \leq 3.5\text{ A}$, $di/dt \leq 400\text{ A}/\mu\text{s}$; $V_{DS\text{ peak}} < V_{(BR)DSS}$, $V_{DD} = 400\text{ V}$.
3. $V_{DS} \leq 480\text{ V}$.

Table 2. Thermal data

Symbol	Parameter	Value			Unit
		DPAK	TO-220	IPAK	
$R_{thj-case}$	Thermal resistance junction-case	2.8			$^\circ\text{C}/\text{W}$
$R_{thj-pcb}^{(1)}$	Thermal resistance junction-pcb	50			
$R_{thj-amb}$	Thermal resistance junction-ambient		62.5	100	

1. When mounted on 1 inch² FR-4, 2 Oz copper board.

Table 3. Avalanche characteristics

Symbol	Parameter	Value	Unit
I_{AR}	Avalanche current, repetitive or not repetitive ⁽¹⁾	0.5	A
E_{AS}	Single pulse avalanche energy ⁽²⁾	80	mJ

1. Pulse width limited by T_{jmax}
2. Starting $T_j = 25\text{ }^\circ\text{C}$, $I_D = I_{AR}$, $V_{DD} = 50\text{ V}$

2 Electrical characteristics

($T_{case} = 25\text{ °C}$ unless otherwise specified)

Table 4. On/off states

Symbol	Parameter	Test conditions	Min.	Typ.	Max.	Unit
$V_{(BR)DSS}$	Drain-source breakdown voltage	$V_{GS} = 0\text{ V}$, $I_D = 1\text{ mA}$	600			V
I_{DSS}	Zero gate voltage drain current	$V_{GS} = 0\text{ V}$, $V_{DS} = 600\text{ V}$			1	μA
		$V_{GS} = 0\text{ V}$, $V_{DS} = 600\text{ V}$, $T_C = 125\text{ °C}$ ⁽¹⁾			100	
I_{GSS}	Gate-body leakage current	$V_{DS} = 0\text{ V}$, $V_{GS} = \pm 25\text{ V}$			± 10	μA
$V_{GS(th)}$	Gate threshold voltage	$V_{DS} = V_{GS}$, $I_D = 250\text{ }\mu\text{A}$	2	3	4	V
$R_{DS(on)}$	Static drain-source on-resistance	$V_{GS} = 10\text{ V}$, $I_D = 1.7\text{ A}$		1.3	1.4	Ω

1. Defined by design, not subject to production test.

Table 5. Dynamic

Symbol	Parameter	Test conditions	Min.	Typ.	Max.	Unit
C_{iss}	Input capacitance	$V_{DS} = 100\text{ V}$, $f = 1\text{ MHz}$, $V_{GS} = 0\text{ V}$	-	211	-	pF
C_{oss}	Output capacitance		-	13	-	
C_{rss}	Reverse transfer capacitance		-	0.75	-	
$C_{oss\ eq.}^{(1)}$	Equivalent output capacitance	$V_{DS} = 0\text{ to }480\text{ V}$, $V_{GS} = 0\text{ V}$	-	19.5	-	pF
R_G	Intrinsic gate resistance	$f = 1\text{ MHz}$ open drain	-	6.2	-	Ω
Q_g	Total gate charge	$V_{DD} = 480\text{ V}$, $I_D = 3.5\text{ A}$, $V_{GS} = 0\text{ to }10\text{ V}$ (see Figure 16. Test circuit for gate charge behavior)	-	8	-	nC
Q_{gs}	Gate-source charge		-	1.6	-	
Q_{gd}	Gate-drain charge		-	4.4	-	

1. $C_{oss\ eq.}$ is defined as a constant equivalent capacitance giving the same charging time as C_{oss} when V_{DS} increases from 0 to 80% V_{DSS} .

Table 6. Switching times

Symbol	Parameter	Test conditions	Min.	Typ.	Max.	Unit
$t_{d(on)}$	Turn-on delay time	$V_{DD} = 300\text{ V}$, $I_D = 1.7\text{ A}$, $R_G = 4.7\text{ }\Omega$, $V_{GS} = 10\text{ V}$ (see Figure 15. Test circuit for resistive load switching times and Figure 20. Switching time waveform)	-	12	-	ns
t_r	Rise time		-	3	-	
$t_{d(off)}$	Turn-off delay time		-	70	-	
t_f	Fall time		-	15	-	

Table 7. Source-drain diode

Symbol	Parameter	Test conditions	Min.	Typ.	Max.	Unit
I_{SD}	Source-drain current		-		3.5	A
$I_{SDM}^{(1)}$	Source-drain current (pulsed)		-		14	A
$V_{SD}^{(2)}$	Forward on voltage	$V_{GS} = 0\text{ V}$, $I_{SD} = 3.5\text{ A}$	-		1.6	V
t_{rr}	Reverse recovery time	$I_{SD} = 3.5\text{ A}$, $di/dt = 100\text{ A}/\mu\text{s}$, $V_{DD} = 60\text{ V}$	-	220		ns
Q_{rr}	Reverse recovery charge		-	1.05		μC
I_{RRM}	Reverse recovery current	(see Figure 17. Test circuit for inductive load switching and diode recovery times)	-	9.5		A
t_{rr}	Reverse recovery time	$I_{SD} = 3.5\text{ A}$, $di/dt = 100\text{ A}/\mu\text{s}$, $V_{DD} = 60\text{ V}$, $T_j = 150\text{ }^\circ\text{C}$	-	314		ns
Q_{rr}	Reverse recovery charge		-	1.5		μC
I_{RRM}	Reverse recovery current		(see Figure 17. Test circuit for inductive load switching and diode recovery times)	-	9.5	

1. Pulse width is limited by safe operating area.
2. Pulse test: pulse duration = 300 μs , duty cycle 1.5 %.

2.1 Electrical characteristics (curves)
Figure 1. Safe operating area for DPAK and IPAK

Figure 2. Thermal impedance for DPAK and IPAK

Figure 3. Safe operating area for TO-220

Figure 4. Thermal impedance for TO-220

Figure 5. Output characteristics

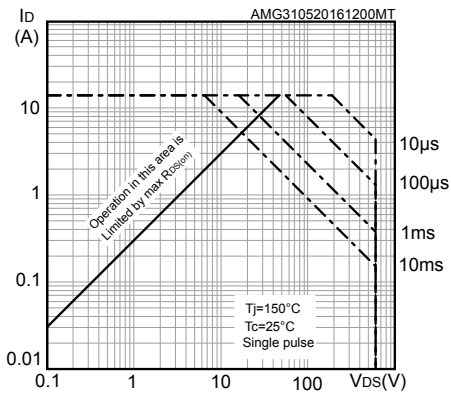
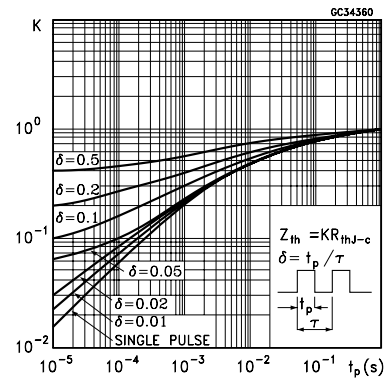
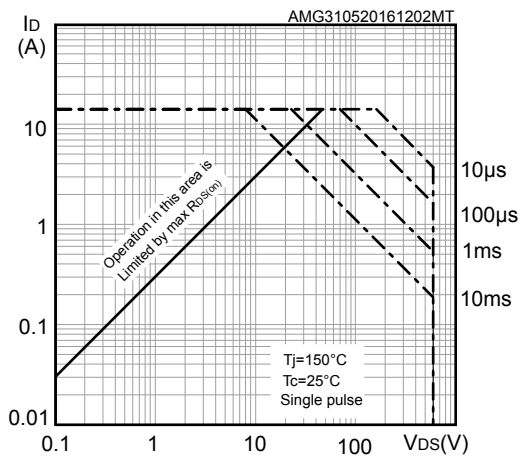
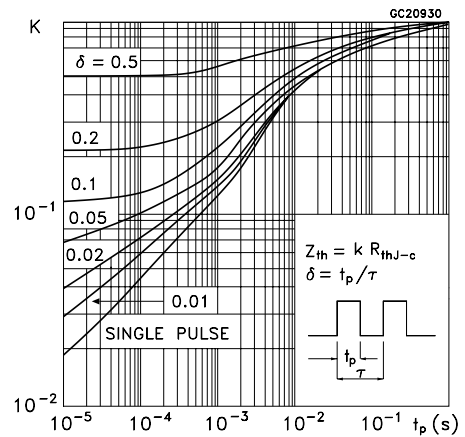
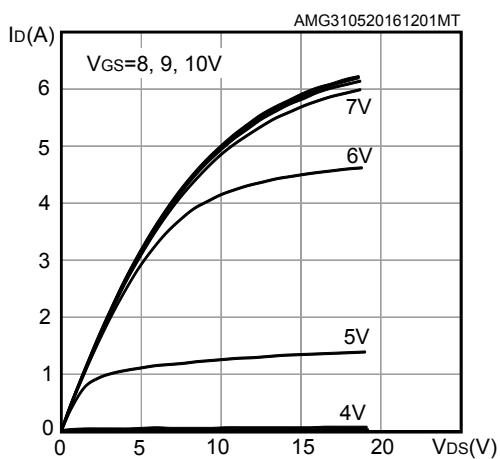
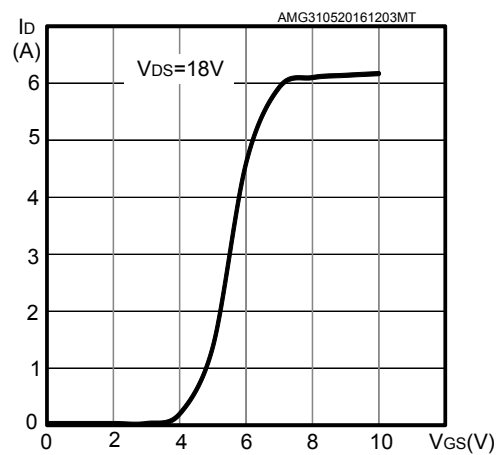
Figure 6. Transfer characteristics

Figure 7. Gate charge vs gate-source voltage

Figure 8. Static drain-source on-resistance

Figure 9. Capacitance variations

Figure 10. Output capacitance stored energy

Figure 11. Normalized gate threshold voltage vs temperature

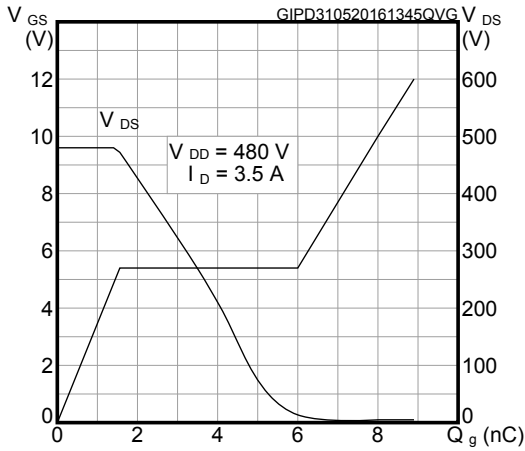
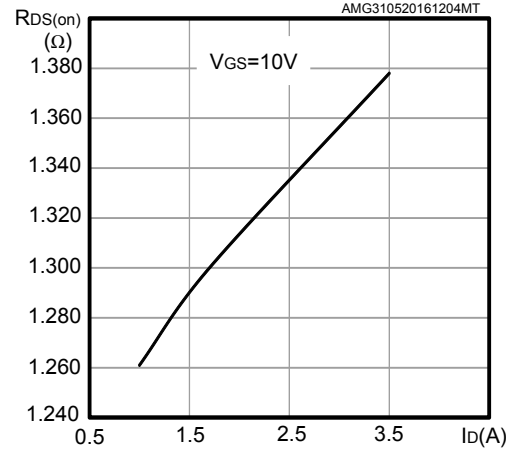
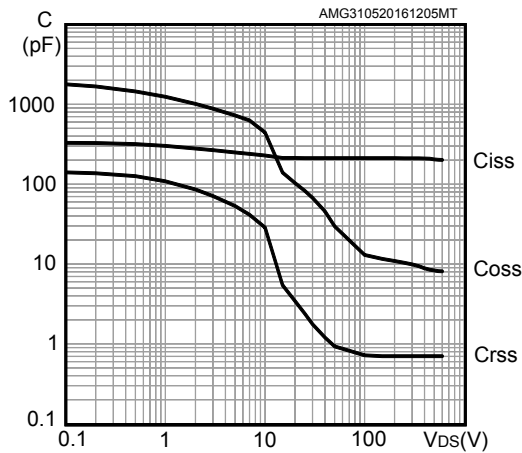
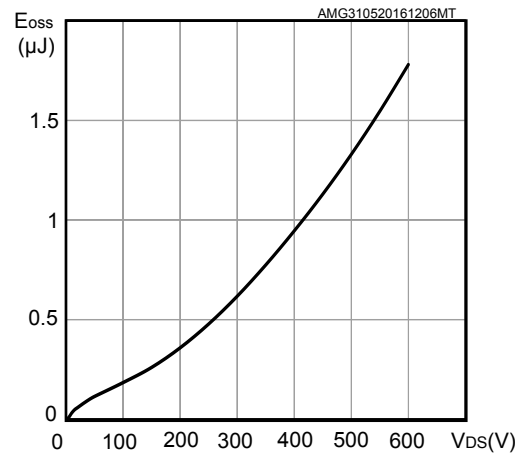
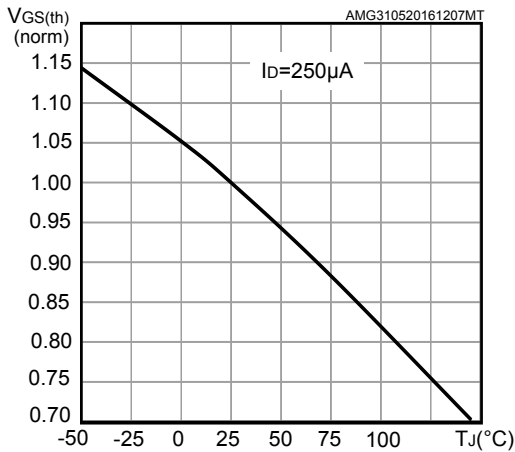
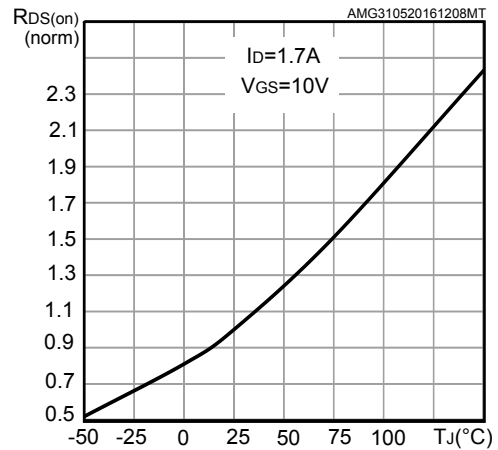
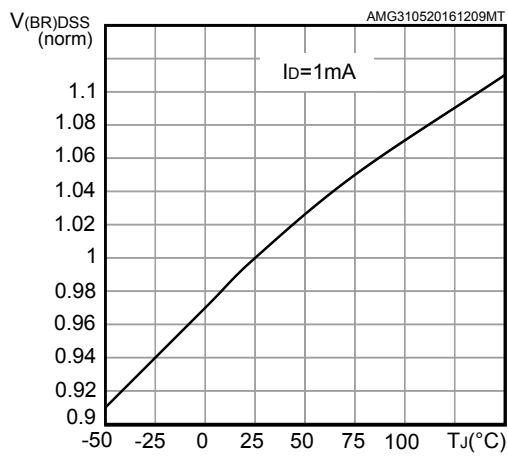
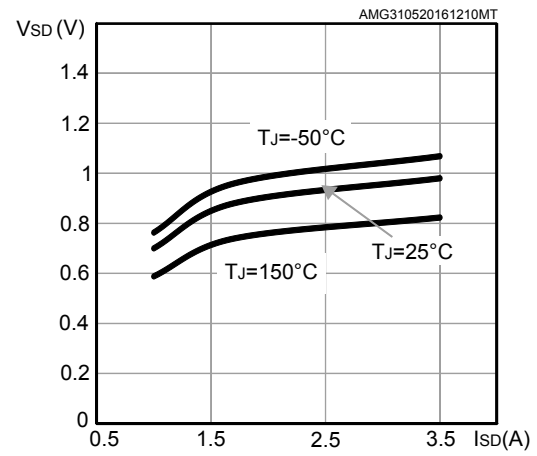
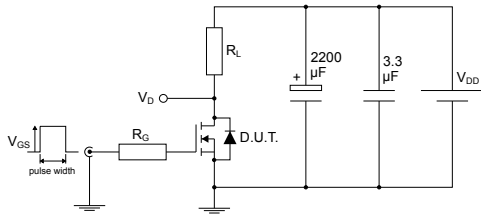
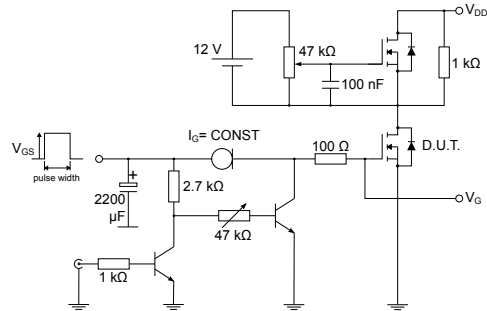
Figure 12. Normalized on-resistance vs temperature

Figure 13. Normalized $V_{(BR)DSS}$ vs temperature

Figure 14. Source-drain diode forward characteristics

3 Test circuits

Figure 15. Test circuit for resistive load switching times

AM01468v1

Figure 16. Test circuit for gate charge behavior

AM01469v1

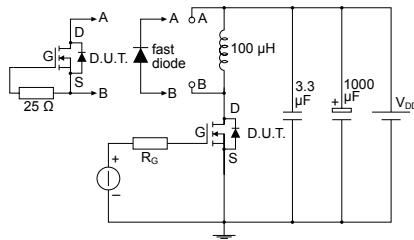
Figure 17. Test circuit for inductive load switching and diode recovery times

AM01470v1

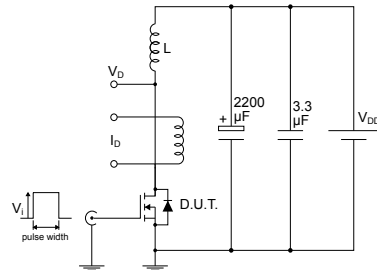
Figure 18. Unclamped inductive load test circuit

AM01471v1

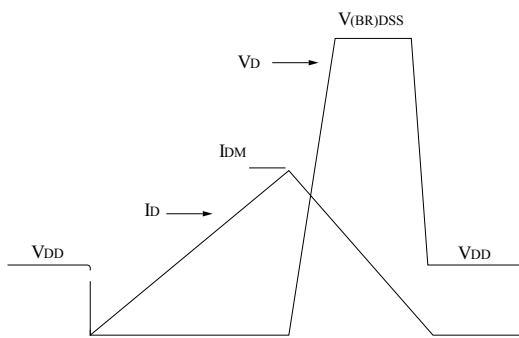
Figure 19. Unclamped inductive waveform

AM01472v1

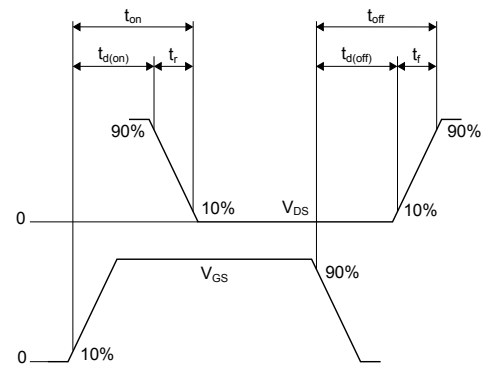
Figure 20. Switching time waveform

AM01473v1

4 Package information

In order to meet environmental requirements, ST offers these devices in different grades of ECOPACK® packages, depending on their level of environmental compliance. ECOPACK® specifications, grade definitions and product status are available at: www.st.com. ECOPACK® is an ST trademark.

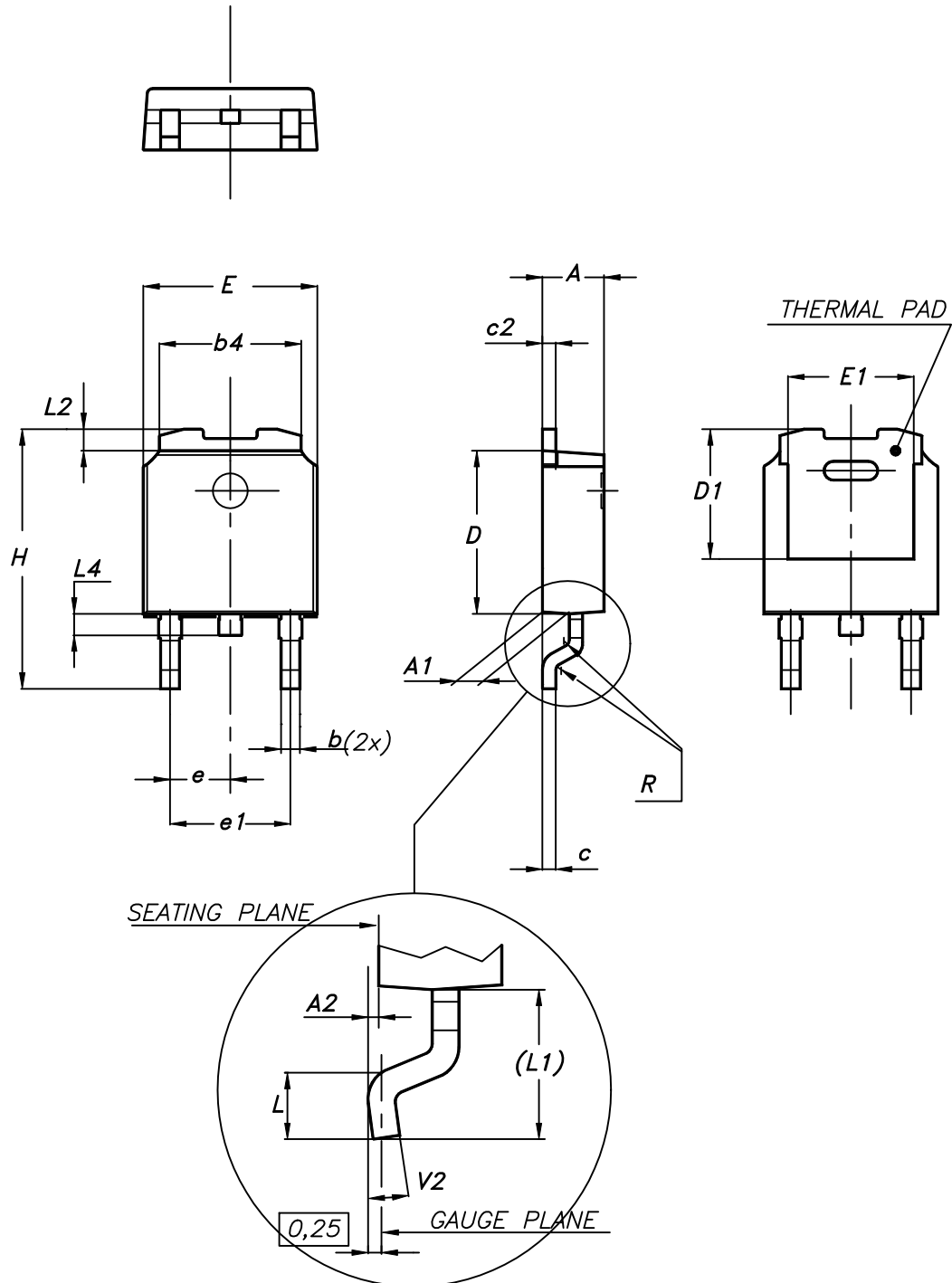
4.1 DPAK (TO-252) type A2 package information
Figure 21. DPAK (TO-252) type A2 package outline

0068772_type-A2_rev25

Table 8. DPAK (TO-252) type A2 mechanical data

Dim.	mm		
	Min.	Typ.	Max.
A	2.20		2.40
A1	0.90		1.10
A2	0.03		0.23
b	0.64		0.90
b4	5.20		5.40
c	0.45		0.60
c2	0.48		0.60
D	6.00		6.20
D1	4.95	5.10	5.25
E	6.40		6.60
E1	5.10	5.20	5.30
e	2.159	2.286	2.413
e1	4.445	4.572	4.699
H	9.35		10.10
L	1.00		1.50
L1	2.60	2.80	3.00
L2	0.65	0.80	0.95
L4	0.60		1.00
R		0.20	
V2	0°		8°

4.2 DPAK (TO-252) type C2 package information

Figure 22. DPAK (TO-252) type C2 package outline

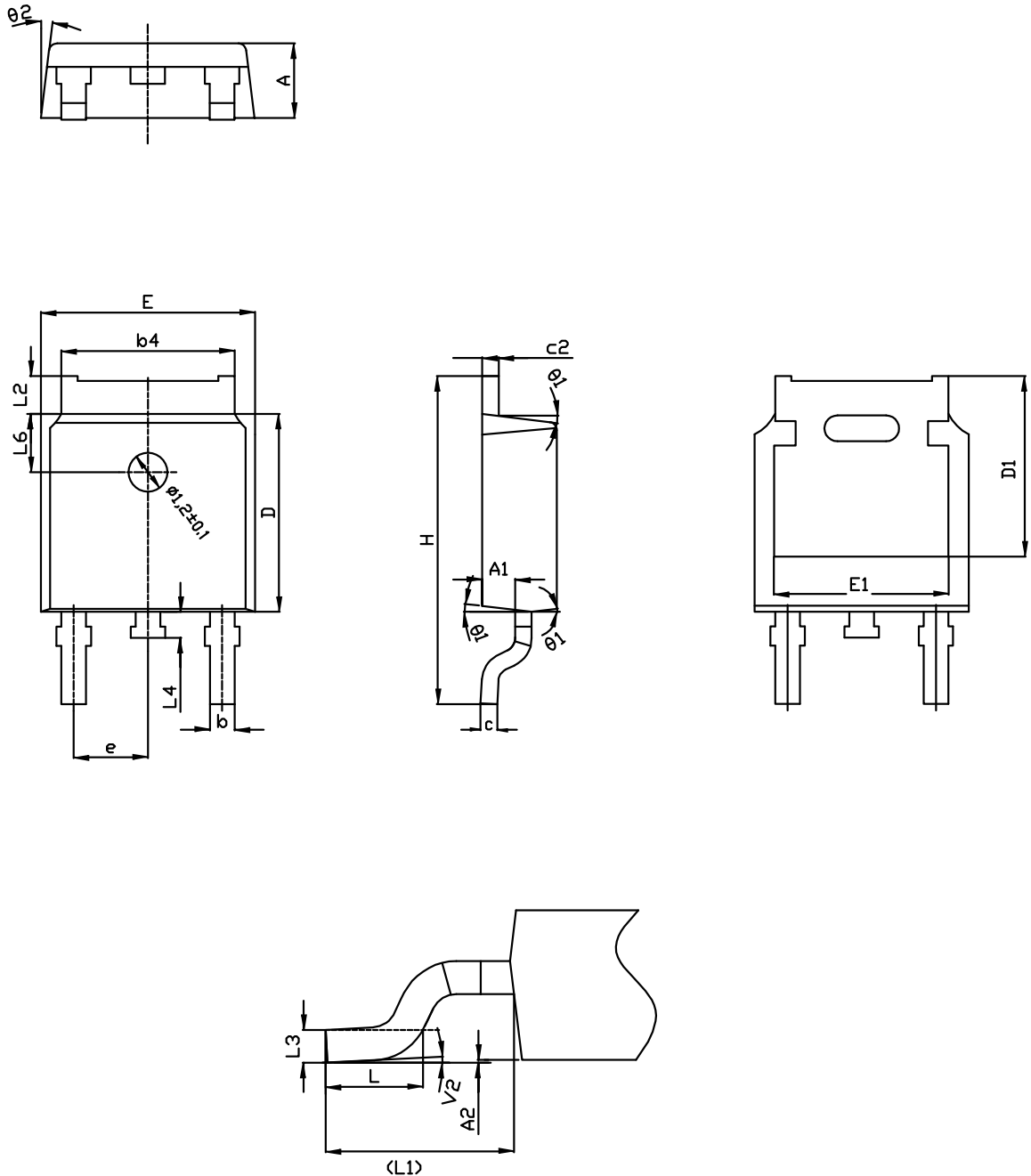

0068772_C2_25

Table 9. DPAK (TO-252) type C2 mechanical data

Dim.	mm		
	Min.	Typ.	Max.
A	2.20	2.30	2.38
A1	0.90	1.01	1.10
A2	0.00		0.10
b	0.72		0.85
b4	5.13	5.33	5.46
c	0.47		0.60
c2	0.47		0.60
D	6.00	6.10	6.20
D1	5.10		5.60
E	6.50	6.60	6.70
E1	5.20		5.50
e	2.186	2.286	2.386
H	9.80	10.10	10.40
L	1.40	1.50	1.70
L1	2.90 REF		
L2	0.90		1.25
L3	0.51 BSC		
L4	0.60	0.80	1.00
L6	1.80 BSC		
θ1	5°	7°	9°
θ2	5°	7°	9°
V2	0°		8°

4.3 DPAK (TO-252) type E package information

Figure 23. DPAK (TO-252) type E package outline

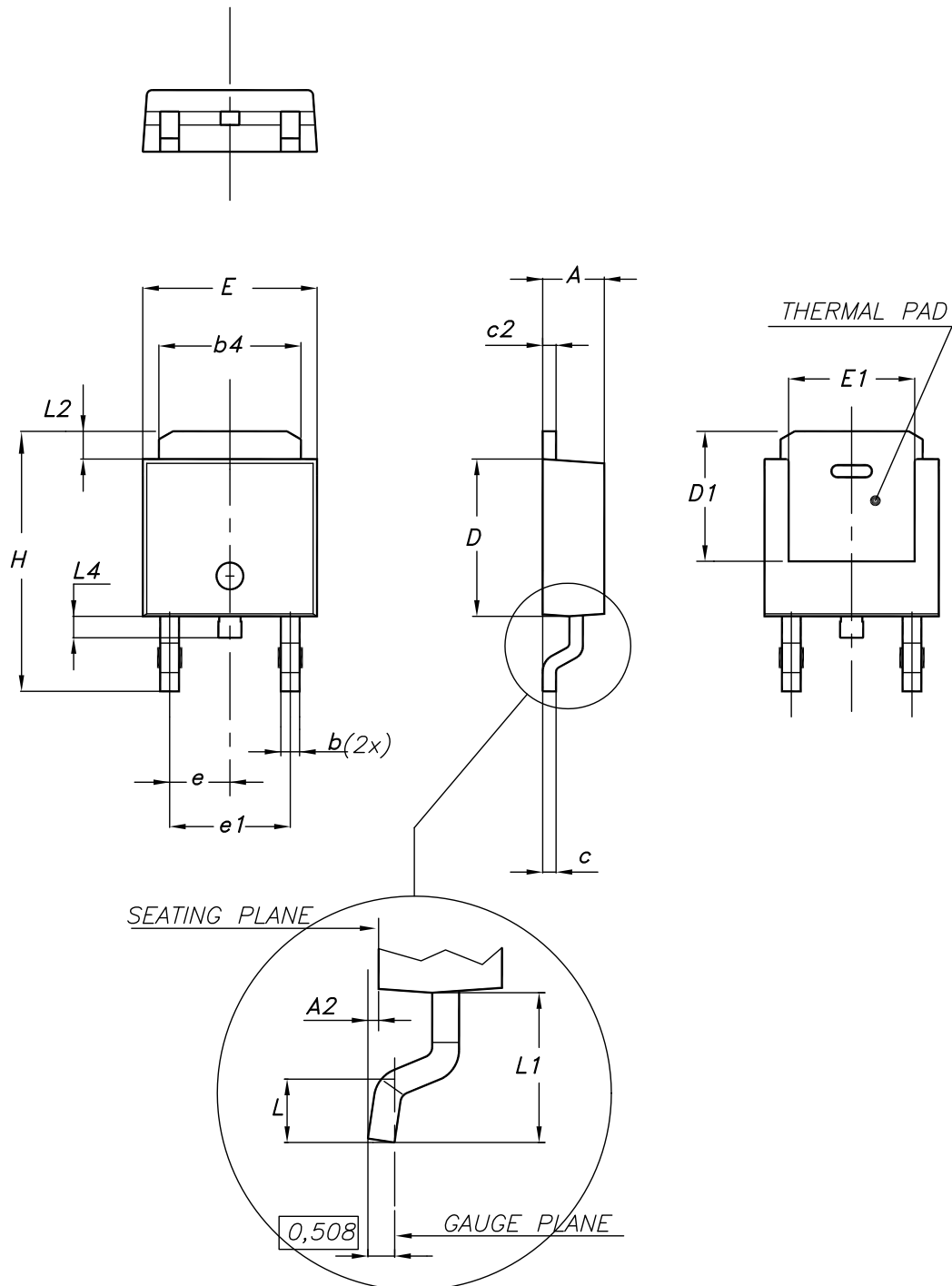

0068772_type-E_rev.25

Table 10. DPAK (TO-252) type E mechanical data

Dim.	mm		
	Min.	Typ.	Max.
A	2.18		2.39
A2			0.13
b	0.65		0.884
b4	4.95		5.46
c	0.46		0.61
c2	0.46		0.60
D	5.97		6.22
D1	5.21		
E	6.35		6.73
E1	4.32		
e		2.286	
e1		4.572	
H	9.94		10.34
L	1.50		1.78
L1		2.74	
L2	0.89		1.27
L4			1.02

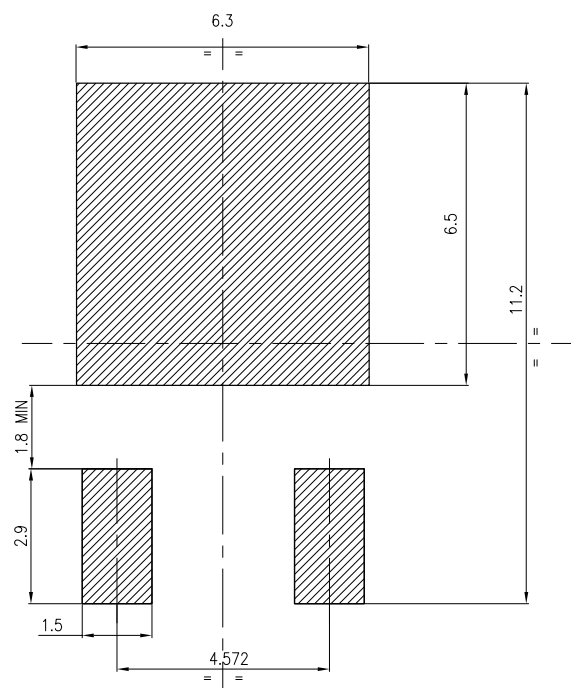
Figure 24. DPAK (TO-252) recommended footprint (dimensions are in mm)

FP_0068772_25

4.4 DPAK (TO-252) packing information

Figure 25. DPAK (TO-252) tape outline

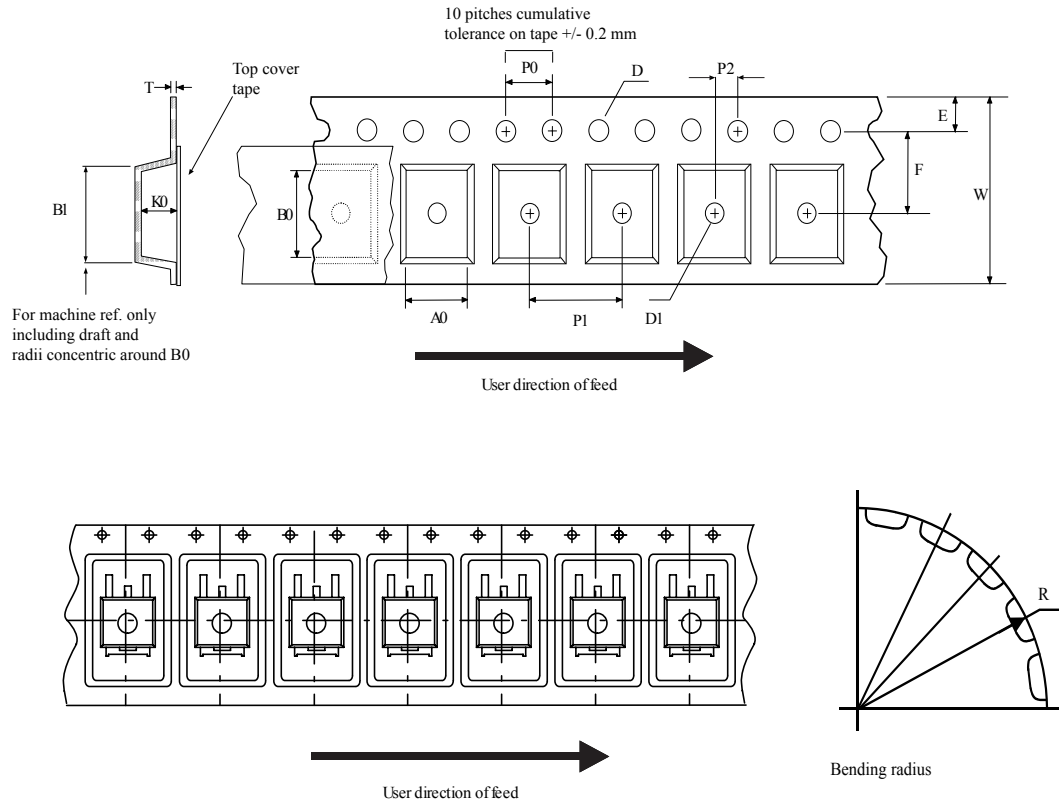

AM08852v1

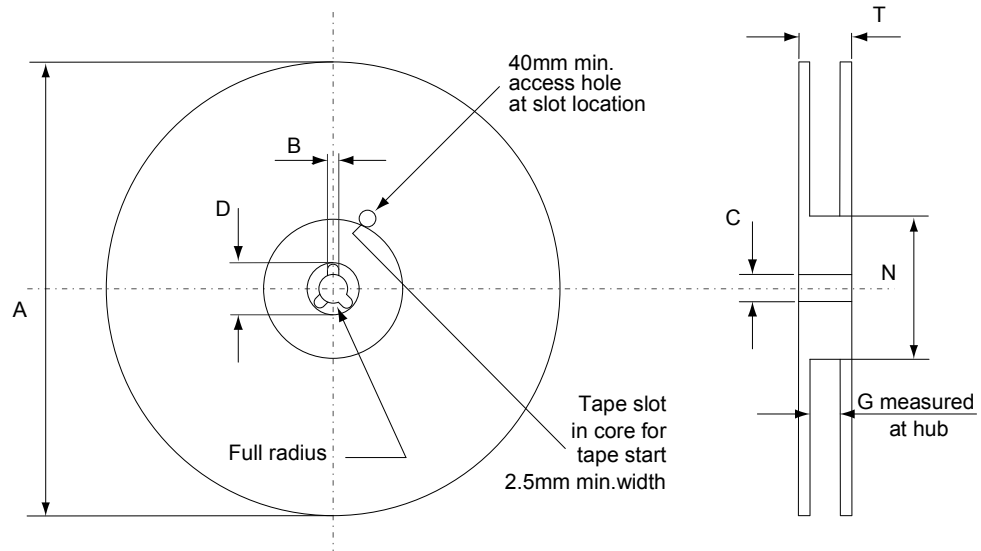
Figure 26. DPAK (TO-252) reel outline

AM06038v1

Table 11. DPAK (TO-252) tape and reel mechanical data

Tape			Reel		
Dim.	mm		Dim.	mm	
	Min.	Max.		Min.	Max.
A0	6.8	7	A		330
B0	10.4	10.6	B	1.5	
B1		12.1	C	12.8	13.2
D	1.5	1.6	D	20.2	
D1	1.5		G	16.4	18.4
E	1.65	1.85	N	50	
F	7.4	7.6	T		22.4
K0	2.55	2.75			
P0	3.9	4.1	Base qty.		2500
P1	7.9	8.1	Bulk qty.		2500
P2	1.9	2.1			
R	40				
T	0.25	0.35			
W	15.7	16.3			

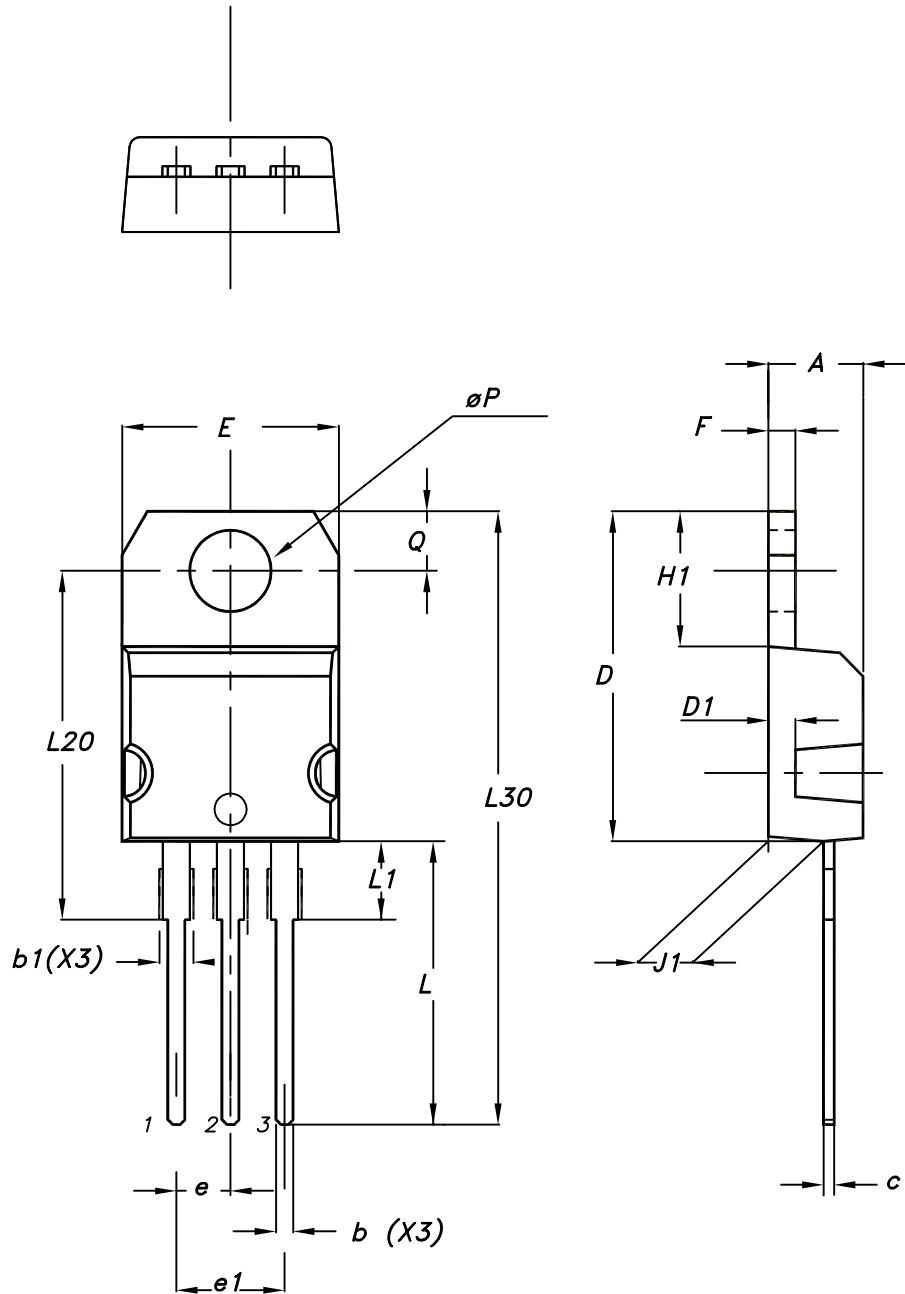
4.5 TO-220 type A package information
Figure 27. TO-220 type A package outline

0015988_typeA_Rev_21

Table 12. TO-220 type A package mechanical data

Dim.	mm		
	Min.	Typ.	Max.
A	4.40		4.60
b	0.61		0.88
b1	1.14		1.55
c	0.48		0.70
D	15.25		15.75
D1		1.27	
E	10.00		10.40
e	2.40		2.70
e1	4.95		5.15
F	1.23		1.32
H1	6.20		6.60
J1	2.40		2.72
L	13.00		14.00
L1	3.50		3.93
L20		16.40	
L30		28.90	
øP	3.75		3.85
Q	2.65		2.95

4.6 IPAk (TO-251) type A package information

Figure 28. IPAk (TO-251) type A package outline

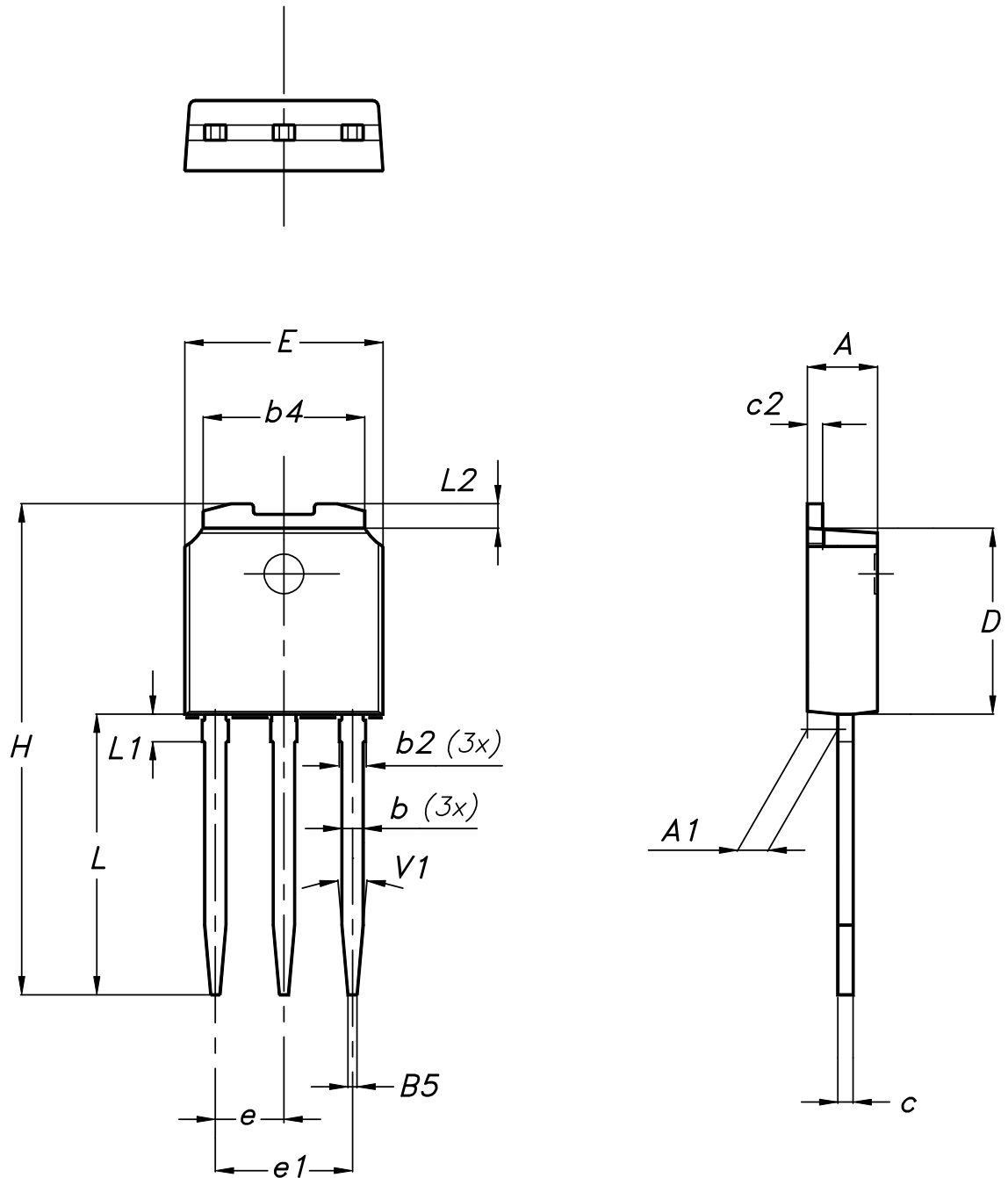

0068771_IK_typeA_rev14

Table 13. IPAK (TO-251) type A package mechanical data

Dim.	mm		
	Min.	Typ.	Max.
A	2.20		2.40
A1	0.90		1.10
b	0.64		0.90
b2			0.95
b4	5.20		5.40
B5		0.30	
c	0.45		0.60
c2	0.48		0.60
D	6.00		6.20
E	6.40		6.60
e		2.28	
e1	4.40		4.60
H		16.10	
L	9.00		9.40
L1	0.80		1.20
L2		0.80	1.00
V1		10°	

4.7 IPAK (TO-251) type C package information

Figure 29. IPAK (TO-251) type C package outline

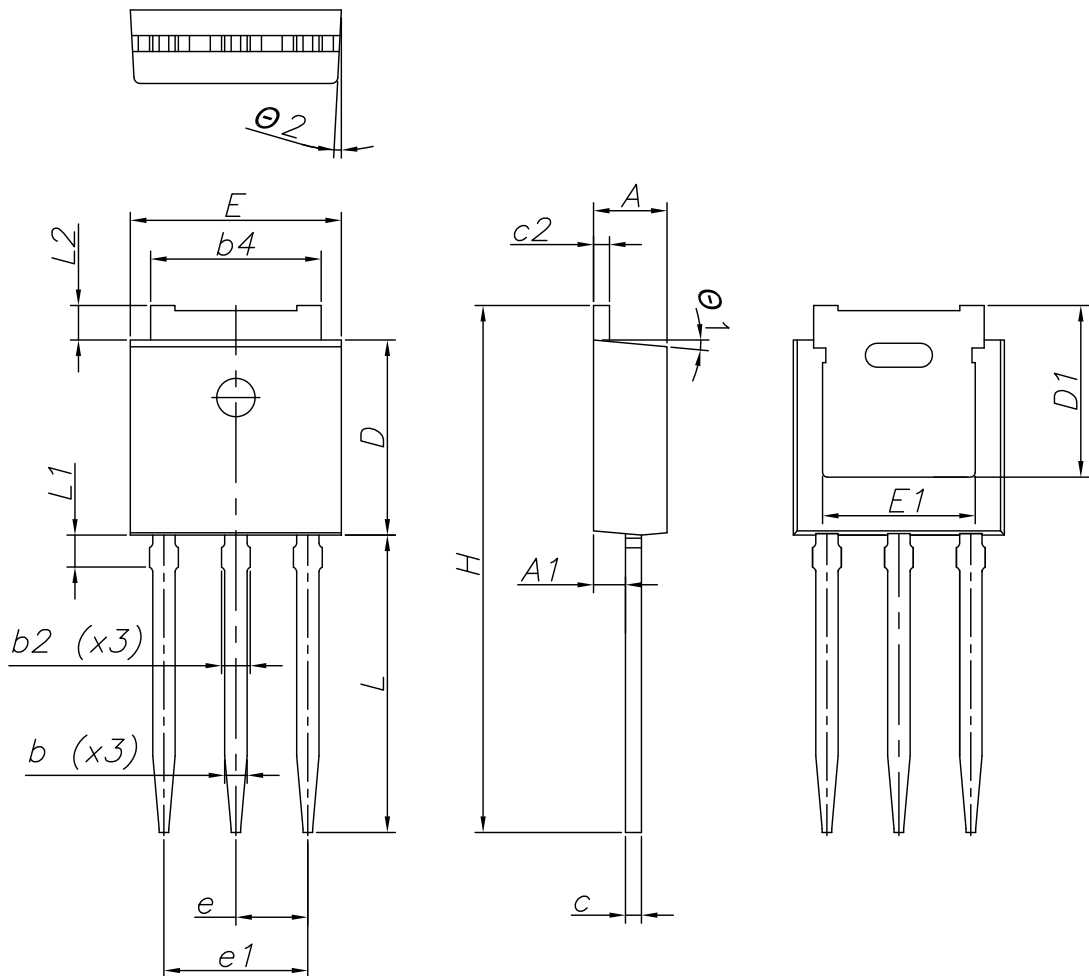

0068771_IK_typeC_rev14

Table 14. IPAK (TO-251) type C package mechanical data

Dim.	mm		
	Min.	Typ.	Max.
A	2.20	2.30	2.35
A1	0.90	1.00	1.10
b	0.66		0.79
b2			0.90
b4	5.23	5.33	5.43
c	0.46		0.59
c2	0.46		0.59
D	6.00	6.10	6.20
D1	5.20	5.37	5.55
E	6.50	6.60	6.70
E1	4.60	4.78	4.95
e	2.20	2.25	2.30
e1	4.40	4.50	4.60
H	16.18	16.48	16.78
L	9.00	9.30	9.60
L1	0.80	1.00	1.20
L2	0.90	1.08	1.25
θ1	3°	5°	7°
θ2	1°	3°	5°

5 Ordering information

Table 15. Ordering information

Order code	Marking	Package	Packing
STD5N60M2	5N60M2	DPAK	Tape and reel
STP5N60M2		TO-220	Tube
STU5N60M2		IPAK	

Revision history

Table 16. Document revision history

Date	Revision	Changes
30-Sep-2013	1	First release.
20-Mar-2014	2	<ul style="list-style-type: none"> – Modified: ID, IDM and note 2 values in Table 2 – Modified: the entire values in Table 4 – Modified: RDS(on) typical and ID values in Table 5 – Modified: the entire typical values, ISD and ISDM in Table 6, 7 and 8 – Updated: Section 4.1: DPAK, STD5N60M2 – Minor text changes
08-Jun-2016	3	<p>Updated title, features, applications and description in cover page. Updated <i>Section 1: "Electrical ratings"</i>, <i>Table 6: "Dynamic"</i> and <i>Section 2.1: "Electrical characteristics (curves)"</i>.</p> <p>Updated IPAK C</p> <p>Minor text changes</p>
16-Jun-2016	4	<p>Updated <i>Figure 1: "Internal schematic diagram"</i>.</p> <p>Updated <i>Table 7: "Switching times"</i> and <i>Table 8: "Source-drain diode"</i>.</p> <p>Minor text changes.</p>
01-Oct-2018	5	<p>Updated Section 4 Package information.</p> <p>Minor text changes</p>

Contents

1	Electrical ratings	2
2	Electrical characteristics	3
2.1	Electrical characteristics (curves)	5
3	Test circuits	8
4	Package information	9
4.1	DPAK (TO-252) type A2 package information	9
4.2	DPAK (TO-252) type C2 package information	11
4.3	DPAK (TO-252) type E package information	13
4.4	DPAK (TO-252) packing information	15
4.5	TO-220 type A package information	17
4.6	IPAK (TO-251) type A package information	19
4.7	IPAK (TO-251) type C package information	21
5	Ordering information	24
	Revision history	25

IMPORTANT NOTICE – PLEASE READ CAREFULLY

STMicroelectronics NV and its subsidiaries (“ST”) reserve the right to make changes, corrections, enhancements, modifications, and improvements to ST products and/or to this document at any time without notice. Purchasers should obtain the latest relevant information on ST products before placing orders. ST products are sold pursuant to ST’s terms and conditions of sale in place at the time of order acknowledgement.

Purchasers are solely responsible for the choice, selection, and use of ST products and ST assumes no liability for application assistance or the design of Purchasers’ products.

No license, express or implied, to any intellectual property right is granted by ST herein.

Resale of ST products with provisions different from the information set forth herein shall void any warranty granted by ST for such product.



ST and the ST logo are trademarks of ST. All other product or service names are the property of their respective owners.

Information in this document supersedes and replaces information previously supplied in any prior versions of this document.





© 2018 STMicroelectronics – All rights reserved

Looking for pricing, stock, or lifecycle information?

Click below to explore more details on WIN SOURCE:

-  [View STD5N60M2 on WIN SOURCE](#)
-  [STMicroelectronics Information](#)

Optimize Your Supply Chain with WIN SOURCE Solutions

-  Global Sourcing Solution
-  Obsolete Management
-  Cost Control Management
-  Shortage Management
-  Alternative Solution
-  Excess Inventory Management