



# THE DATASHEET OF TDA7442D





# TDA7442 TDA7442D

## tone control and surround digitally controlled audio processor

### 1 FEATURES

- 4 STEREO INPUTS
- INPUT ATTENUATION CONTROL IN 0.5dB STEP
- TREBLE AND BASS CONTROL
- TWO SURROUND MODE AVAILABLE WITH 4 SELECTABLE RESPONSES:
  - MUSIC
  - SIMULATED STEREO
- TWO SPEAKER ATTENUATORS:
  - 2 INDEPENDENT SPEAKER CONTROLS IN 1dB STEPS FOR BALANCE FACILITY
  - INDEPENDENT MUTE FUNCTION
- ALL FUNCTIONS PROGRAMMABLE VIA SERIAL BUS
- 2 MONITOR OUTPUT (ONLY FOR TDA7442)

### 2 DESCRIPTION

The TDA7442/42D is volume tone (bass and treble) balance (Left/Right) processors for quality audio applications in TV and Hi-Fi systems.

It reproduces surround sound by using a program-

Figure 1. Packages



Table 1. Order Codes

Part Number	Package
TDA7442	SDIP-32
TDA7442D	SO-28
TDA7442D013TR	Tape & Reel

mable phase shifter. Control of all the functions is accomplished by serial bus.

The AC signal setting is obtained by resistor networks and switches combined with operational amplifiers.

Thanks to the BIPOLAR/CMOS Technology used, Low Distortion, Low Noise and DC stepping are obtained.

Figure 2. Pin Connections (Top views)

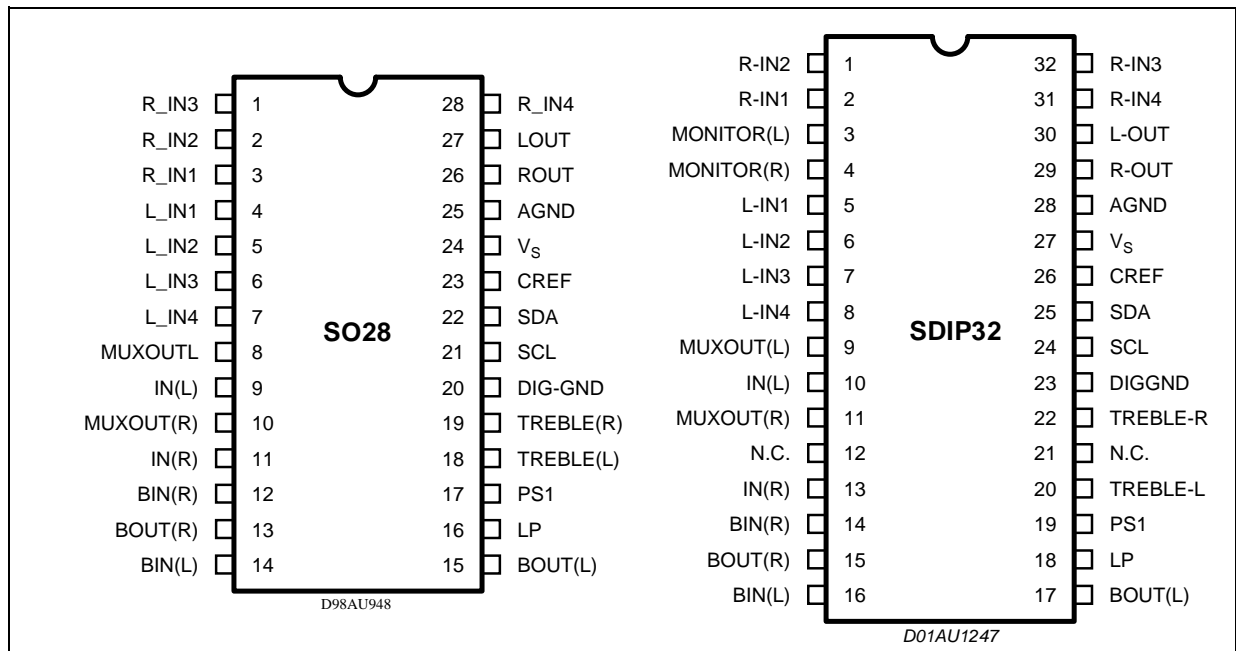

# TDA7442 - TDA7442D

Figure 3. Block Diagram (TDA7442)

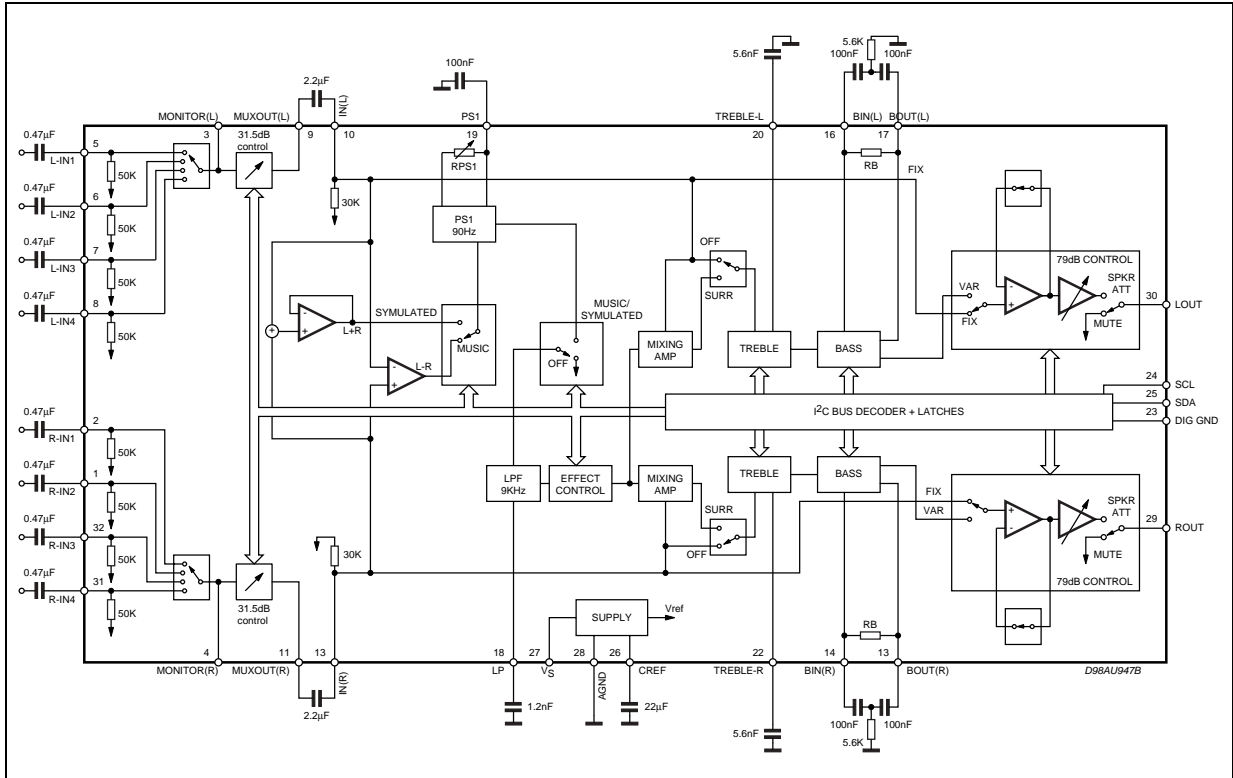

Figure 4. Block Diagram (TDA7442D)

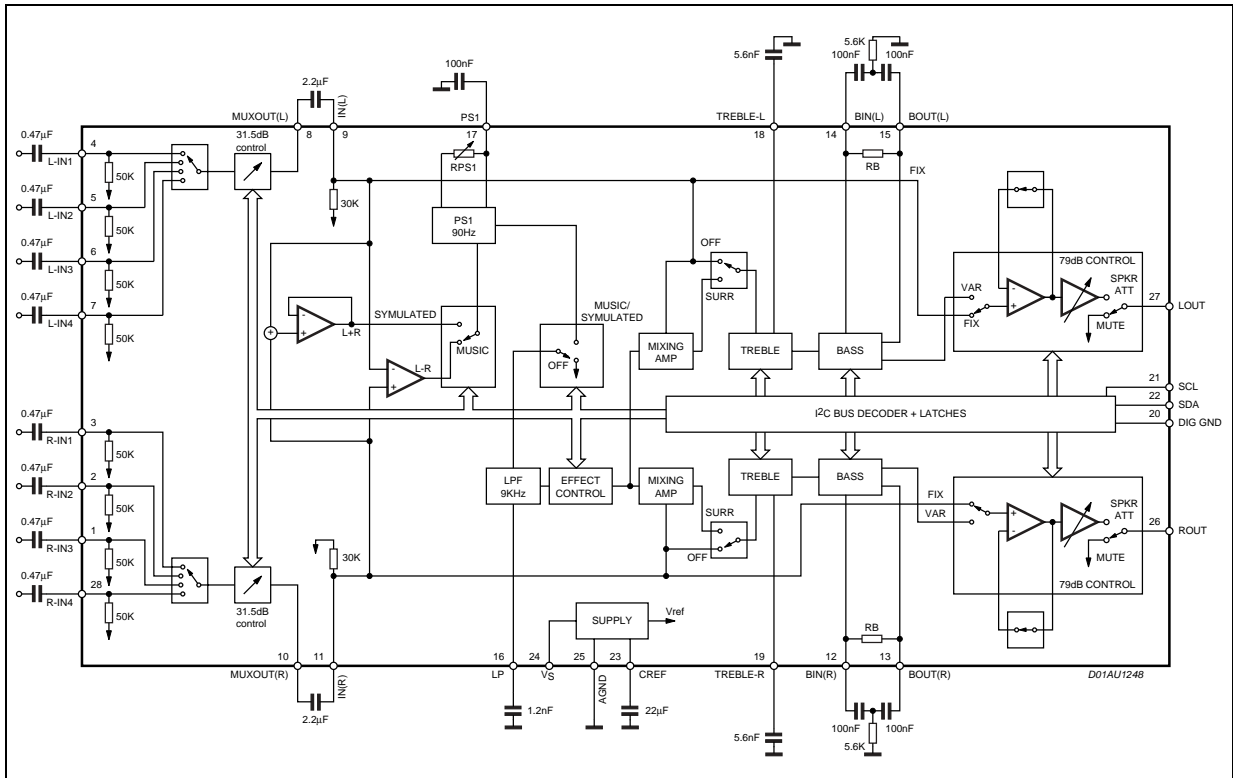

Table 2. Quick Reference Data

Symbol	Parameter	Min.	Typ.	Max.	Unit
V <sub>S</sub>	Supply Voltage	7	9	10.2	V
V <sub>CL</sub>	Max. input signal handling	2			V <sub>rms</sub>
THD	Total Harmonic Distortion V = 1V <sub>rms</sub> f = 1KHz		0.01	0.1	%
S/N	Signal to Noise Ratio V <sub>out</sub> = 1V <sub>rms</sub> (mode = OFF)		106		dB
S <sub>C</sub>	Channel Separation f = 1KHz		90		dB
	Treble Control (2db step)	-14		+14	dB
	Bass Control (2dB step)	-14		+14	dB
	Balance Control 1dB step (L <sub>CH</sub> , R <sub>CH</sub> )	-79		0	dB
	Mute Attenuation		100		dB

Table 3. Thermal Data

Symbol	Parameter	Value	Unit
R <sub>th j-pins</sub>	Thermal Resistance Junction-pins	Max. 85	°C/W

Table 4. Absolute Maximum Ratings

Symbol	Parameter	Value	Unit
V <sub>S</sub>	Operating Supply Voltage	11	V
T <sub>amb</sub>	Operating Ambient Temperature	-10 to 70	°C
T <sub>stg</sub>	Storage Temperature Range	-55 to +150	°C

Table 5. Electrical Characteristics

Refer to the test circuit T<sub>amb</sub> = 25°C, V<sub>S</sub> = 9V, R<sub>L</sub> = 10KΩ, V<sub>in</sub> = 1V<sub>rms</sub>; R<sub>G</sub> = 600Ω, all controls flat (G = 0dB), Effect Ctrl = -6dB, MODE = OFF; f = 1KHz unless otherwise specified.

Symbol	Parameter	Test Condition	Min.	Typ.	Max.	Unit
<b>SUPPLY</b>						
V <sub>S</sub>	Supply Voltage		7	9	10.2	V
I <sub>S</sub>	Supply Current		10	18	26	mA
SVR	Ripple Rejection	L <sub>CH</sub> / R <sub>CH out</sub> , Mode = OFF	60	80		dB
<b>INPUT STAGE</b>						
R <sub>IN</sub>	Input Resistance		35	50	65	KΩ
V <sub>CL</sub>	Clipping Level	THD = 0.3%	2	2.5		V <sub>rms</sub>
C <sub>RANGE</sub>	Control Range			31.5		dB
A <sub>V MIN</sub>	Min. Attenuation		-1	0	1	dB
A <sub>V MAX</sub>	Max. Attenuation		31	31.5	32	dB
A <sub>STEP</sub>	Step Resolution			0.5	1	dB
<b>BASS CONTROL</b>						
G <sub>b</sub>	Control Range	Max. Boost/cut	±11.5	±14.0	±16.0	dB
B <sub>STEP</sub>	Step Resolution		1	2	3	dB
R <sub>B</sub>	Internal Feedback Resistance		32	44	56	KΩ

## TDA7442 - TDA7442D

**Table 5. Electrical Characteristics** (continued)

Refer to the test circuit  $T_{amb} = 25^{\circ}\text{C}$ ,  $V_S = 9\text{V}$ ,  $R_L = 10\text{K}\Omega$ ,  $V_{in} = 1\text{Vrms}$ ;  $R_G = 600\Omega$ , all controls flat ( $G = 0\text{dB}$ ), Effect Ctrl =  $-6\text{dB}$ , MODE = OFF;  $f = 1\text{KHz}$  unless otherwise specified.

Symbol	Parameter	Test Condition	Min.	Typ.	Max.	Unit
<b>TREBLE CONTROL</b>						
$G_t$	Control Range	Max. Boost/cut	+13.0	+14.0	+15.0	dB
$T_{STEP}$	Step Resolution		1	2	3	dB
<b>EFFECT CONTROL</b>						
$C_{RANGE}$	Control Range		-21		-6	dB
$S_{STEP}$	Step Resolution		0.5	1	1.5	dB
<b>SURROUND SOUND MATRIX PHASE</b>						
$R_{PS10}$	Phase Shifter 1: $D1 = 0, D0 = 0$		8.3	11.8	15.2	$\text{K}\Omega$
$R_{PS11}$	Phase Shifter 1: $D1 = 0, D0 = 1$		10	14.1	18.3	$\text{K}\Omega$
$R_{PS12}$	Phase Shifter 1: $D1 = 1, D0 = 0$		12.6	17.9	23.3	$\text{K}\Omega$
$R_{PS13}$	Phase Shifter 1: $D1 = 1, D0 = 1$		26.4	37.3	48.85	$\text{K}\Omega$
<b>SURROUND SOUND MATRIX TEST CONDITION</b> (Phase Resistor Selection $D0=0, D1=1, D2=0, D3=1, D4=0, D5=1, D6=0, D7=1$ )						
$G_{OFF}$	In-phase Gain (OFF)	Mode OFF, Input signal of 1kHz, $1.4 V_{p-p}$ , $R_{in} \rightarrow R_{out}$ , $L_{in} \rightarrow L_{out}$	-1	0	1	dB
$D_{GOFF}$	LR In-phase Gain Difference (OFF)	Mode OFF, Input signal of 1kHz, $1.4 V_{p-p}$ , $R_{in} \rightarrow R_{out}$ , $L_{in} \rightarrow L_{out}$	-1	0	1	dB
$G_{MUS}$	In-phase Gain (Music)	Music mode, Effect Ctrl = $-6\text{dB}$ , Input signal of 1kHz, $1.4 V_{p-p}$ ( $R_{in} \rightarrow R_{out}$ ), ( $L_{in} \rightarrow L_{out}$ )		7		dB
$D_{GMUS}$	LR In-phase Gain Difference (Music)	Music mode, Effect Ctrl = $-6\text{dB}$ , Input signal of 1kHz, $1.4 V_{p-p}$ ( $R_{in} \rightarrow R_{out}$ ) - ( $L_{in} \rightarrow L_{out}$ )		0		dB
<b>SPEAKER ATTENUATORS</b>						
$C_{range}$	Control Range			79		dB
$S_{STEP}$	Step Resolution		-0.5	1	1.5	dB
$E_A$	Attenuation set error	$A_v = 0$ to $-20\text{dB}$	-1.5	0	1.5	dB
		$A_v = -20$ to $-79\text{dB}$	-3	0	2	dB
$V_{DC}$	DC Steps	adjacent att. steps	-3	0	3	mV
$A_{MUTE}$	Output Mute Condition		+70	100		dB
$R_{VEA}$	Input Impedance		21	30	39	$\text{K}\Omega$
<b>AUDIO OUTPUTS</b>						
$N_{O(OFF)}$	Output Noise (OFF)	Output Mute, Flat $B_W = 20\text{Hz}$ to $20\text{KHz}$		4		$\mu\text{Vrms}$
				5		$\mu\text{Vrms}$
$N_{O(MUS)}$	Output Noise (Music)	Mode = Music, $B_W = 20\text{Hz}$ to $20\text{KHz}$ ,		30		mVrms
$N_{O(PSEUDO)}$	Output Noise (Pseudo Stereo)	Mode = Pseudo Stereo $B_W = 20\text{Hz}$ to $20\text{KHz}$ ,		30		mVrms
$d$	Distorsion	$A_v = 0$ ; $V_{in} = 1\text{Vrms}$		0.01	0.1	%
$S_C$	Channel Separation		70	90		dB
$V_{OCL}$	Clipping Level	$d = 0.3\%$	2	2.5		Vrms
$R_{OUT}$	Output Resistance		10	30	50	$\Omega$

**Table 5. Electrical Characteristics** (continued)

Refer to the test circuit  $T_{amb} = 25^{\circ}\text{C}$ ,  $V_S = 9\text{V}$ ,  $R_L = 10\text{K}\Omega$ ,  $V_{in} = 1\text{Vrms}$ ;  $R_G = 600\Omega$ , all controls flat ( $G = 0\text{dB}$ ), Effect Ctrl =  $-6\text{dB}$ , MODE = OFF;  $f = 1\text{KHz}$  unless otherwise specified.

Symbol	Parameter	Test Condition	Min.	Typ.	Max.	Unit
$V_{OUT}$	DC Voltage Level			3.8		V
MONITOR OUTPUTS						
d	Distorsion	$A_v = 0$ ; $V_{in} = 1\text{Vrms}$		0.01	0.1	%
$S_C$	Channel Separation		70	90		dB
$V_{OCL}$	Clipping Level	$d = 0.3\%$	2	2.5		Vrms
$R_{OUT}$	Output Resistance		20	50	70	$\Omega$
$V_{OUT}$	DC Voltage Level			4.5		V
BUS INPUTS						
$V_{IL}$	Input Low Voltage				1	V
$V_{IH}$	Input High Voltage		3			V
$I_{IN}$	Input Current		-5		+5	$\mu\text{A}$
$V_O$	Output Voltage SDA Acknowledge	$I_O = 1.6\text{mA}$			0.4	V

### 3 I<sup>2</sup>C BUS INTERFACE

Data transmission from microprocessor to the TDA7442D and vice versa takes place through the 2 wires I<sup>2</sup>C BUS interface, consisting of the two lines SDA and SCL (pull-up resistors to positive supply voltage must be connected).

#### 3.1 Data Validity

As shown in fig. 5, the data on the SDA line must be stable during the high period of the clock. The HIGH and LOW state of the data line can only change when the clock signal on the SCL line is LOW.

#### 3.2 Start and Stop Conditions

As shown in fig. 6 a start condition is a HIGH to LOW transition of the SDA line while SCL is HIGH. The stop condition is a LOW to HIGH transition of the SDA line while SCL is HIGH.

#### 3.3 Byte Format

Every byte transferred on the SDA line must contain 8 bits. Each byte must be followed by an acknowledge bit. The MSB is transferred first.

#### 3.4 Acknowledge

The master ( $\mu$ P) puts a restive HIGH level on the SDA line during the acknowledge clock pulse (see fig. 3). The peripheral (audio processor) that acknowledges has to pull-down (LOW) the SDA line during this clock pulse.

The audio processor which has been addressed has to generate an acknowledge after the reception of each byte, otherwise the SDA line remains at the HIGH level during the ninth clock pulse. In this case the master transmitter can generate the STOP information in order to abort the transfer.

#### 3.5 Transmission without Acknowledge

Avoiding to detect the acknowledge of the audio processor, the  $\mu$ P can use a simpler transmission: simply it waits one clock without checking the slave acknowledging, and sends the new data.

This approach of course is less protected from misworking.

Figure 5. Data Validity on the I<sup>2</sup>CBUS

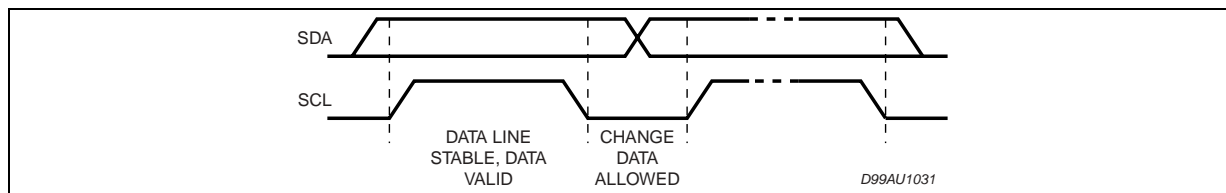

Figure 6. Timing Diagram of I<sup>2</sup>CBUS

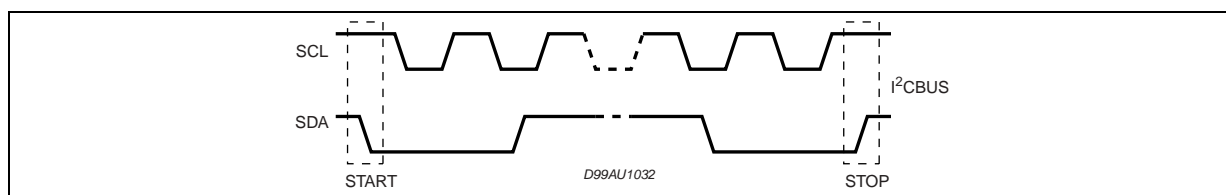
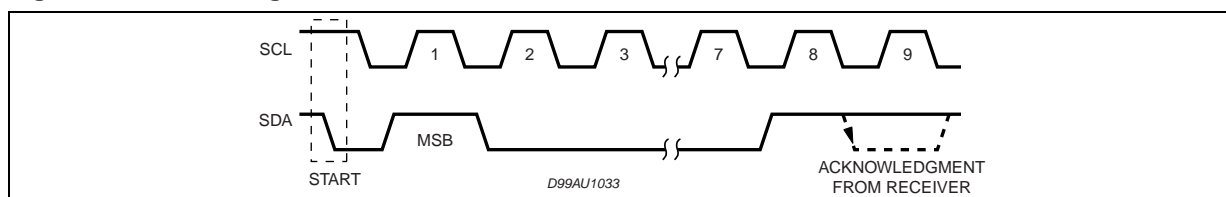

Figure 7. Acknowledge on the I<sup>2</sup>CBUS





## 5 DATA BYTES

Address = 80(HEX)

### 5.1 Function Selection:

The first byte (subaddress)

MSB							LSB		SUBADDRESS
D7	D6	D5	D4	D3	D2	D1	D0		
B	X	X	X	0	0	0	0	INPUT ATTENUATION	
B	X	X	X	0	0	0	1	SURROUND & OUT & EFFECT CONTROL	
B	X	X	X	0	0	1	0	PHASE RESISTOR	
B	X	X	X	0	0	1	1	BASS	
B	X	X	X	0	1	0	0	TREBLE	
B	X	X	X	0	1	0	1	SPEAKER ATTENUATION "L"	
B	X	X	X	0	1	1	0	SPEAKER ATTENUATION "R"	
B	X	X	X	0	1	1	1	NOT ALLOWED	
B	X	X	X	1	0	0	0	NOT ALLOWED	
B	X	X	X	1	0	0	1	INPUT MULTIPLEXER	

B = 1 incremental bus; active

B = 0 no incremental bus;

X = indifferent 0,1

Input Attenuation Selection

MSB							LSB		INPUT ATTENUATION
D7	D6	D5	D4	D3	D2	D1	D0	0.5 dB STEPS	
	1				0	0	0	0	
	1				0	0	1	-0.5	
	1				0	1	0	-1	
	1				0	1	1	-1.5	
	1				1	0	0	-2	
	1				1	0	1	-2.5	
	1				1	1	0	-3	
	1				1	1	1	-3.5	
								<b>4 dB STEPS</b>	
	1	0	0	0				0	
	1	0	0	1				-4	
	1	0	1	0				-8	
	1	0	1	1				-12	
	1	1	0	0				-16	
	1	1	0	1				-20	
	1	1	1	0				-24	
	1	1	1	1				-28	

INPUT ATTENUATION = 0 ~ -31.5dB

## 5.2 Surround Selection

MSB							LSB		
D7	D6	D5	D4	D3	D2	D1	D0	SURROUND MODE	
						0	0	SIMULATED STEREO	
						0	1	MUSIC	
						1	0	OFF	
								OUT	
					0			VAR	
					1			FIX	
								<b>EFFECT CONTROL</b>	
	0	0	0	0				-6	
	0	0	0	1				-7	
	0	0	1	0				-8	
	0	0	1	1				-9	
	0	1	0	0				-10	
	0	1	0	1				-11	
	0	1	1	0				-12	
	0	1	1	1				-13	
	1	0	0	0				-14	
	1	0	0	1				-15	
	1	0	1	0				-16	
	1	0	1	1				-17	
	1	1	0	0				-18	
	1	1	0	1				-19	
	1	1	1	0				-20	
	1	1	1	1				-21	
<b>PHASE RESISTOR SELECTION</b>									
MSB							LSB		SURROUND PHASE RESISTOR
D7	D6	D5	D4	D3	D2	D1	D0	PHASE SHIFT 1 (K $\Omega$ )	
						0	0	12	
						0	1	14	
						1	0	18	
						1	1	37	
<b>BASS SELECTION</b>									
MSB							LSB		BASS
D7	D6	D5	D4	D3	D2	D1	D0	2 dB STEPS	
X	X	X	1	0	0	0	0	-14	
X	X	X	1	0	0	0	1	-12	
X	X	X	1	0	0	1	0	-10	
X	X	X	1	0	0	1	1	-8	
X	X	X	1	0	1	0	0	-6	
X	X	X	1	0	1	0	1	-4	
X	X	X	1	0	1	1	0	-2	
X	X	X	1	0	1	1	1	0	
X	X	X	1	1	1	1	1	0	

5.2 Surround Selection (continued)

MSB								LSB	BASS
D7	D6	D5	D4	D3	D2	D1	D0	2 dB STEPS	
X	X	X	1	1	1	1	0	2	
X	X	X	1	1	1	0	1	4	
X	X	X	1	1	1	0	0	6	
X	X	X	1	1	0	1	1	8	
X	X	X	1	1	0	1	0	10	
X	X	X	1	1	0	0	1	12	
X	X	X	1	1	0	0	0	14	
SPEAKER SELECTION									
MSB								LSB	SPEAKER/ATT
D7	D6	D5	D4	D3	D2	D1	D0	1 dB STEPS	
X					0	0	0	0	
X					0	0	1	-1	
X					0	1	0	-2	
X					0	1	1	-3	
X					1	0	0	-4	
X					1	0	1	-5	
X					1	1	0	-6	
X					1	1	1	-7	
								8 dB STEPS	
X	0	0	0	0				0	
X	0	0	0	1				-8	
X	0	0	1	0				-16	
X	0	0	1	1				-24	
X	0	1	0	0				-32	
X	0	1	0	1				-40	
X	0	1	1	0				-48	
X	0	1	1	1				-56	
X	1	0	0	0				-64	
X	1	0	0	1				-72	
								MUTE	
X	1	0	1	X					
X	1	1	X	X					
X = INDIFFERENT 0,1 SPEAKER ATTENUATION = 0dB ~ -79dB									
TREBLE SELECTION									
MSB								LSB	TREBLE
D7	D6	D5	D4	D3	D2	D1	D0	2 dB STEPS	
0	0	0	0	1	1	1	0	-14	
0	0	0	1	1	1	1	0	-12	
0	0	1	0	1	1	1	0	-10	
0	0	1	1	1	1	1	0	-8	
0	1	0	0	1	1	1	0	-6	
0	1	0	1	1	1	1	0	-4	

## 5.2 Surround Selection (continued)

MSB							LSB	TREBLE
D7	D6	D5	D4	D3	D2	D1	D0	2 dB STEPS
0	1	1	0	1	1	1	0	-2
0	1	1	1	1	1	1	0	0
1	1	1	1	1	1	1	0	0
1	1	1	0	1	1	1	0	2
1	1	0	1	1	1	1	0	4
1	1	0	0	1	1	1	0	6
1	0	1	1	1	1	1	0	8
1	0	1	0	1	1	1	0	10
1	0	0	1	1	1	1	0	12
1	0	0	0	1	1	1	0	14

## INPUT SELECTION

MSB							LSB	INPUT MULTIPLEXER
D7	D6	D5	D4	D3	D2	D1	D0	
X					0	0	0	IN2
X					0	1	0	IN3
X					1	0	0	IN4
X					1	1	0	IN1

X = INDIFFERENT 0,1

SPEAKER ATTENUATION = 0dB ~ -79dB

## TREBLE SELECTION

MSB							LSB	TREBLE
D7	D6	D5	D4	D3	D2	D1	D0	2 dB STEPS
0	0	0	0	1	1	1	0	-14
0	0	0	1	1	1	1	0	-12
0	0	1	0	1	1	1	0	-10
0	0	1	1	1	1	1	0	-8
0	1	0	0	1	1	1	0	-6
0	1	0	1	1	1	1	0	-4
0	1	1	0	1	1	1	0	-2
0	1	1	1	1	1	1	0	0
1	1	1	1	1	1	1	0	0
1	1	1	0	1	1	1	0	2
1	1	0	1	1	1	1	0	4
1	1	0	0	1	1	1	0	6
1	0	1	1	1	1	1	0	8
1	0	1	0	1	1	1	0	10
1	0	0	1	1	1	1	0	12
1	0	0	0	1	1	1	0	14

## INPUT SELECTION

MSB							LSB	INPUT MULTIPLEXER
D7	D6	D5	D4	D3	D2	D1	D0	
X					0	0	0	IN2
X					0	1	0	IN3
X					1	0	0	IN4
X					1	1	0	IN1

Table 6.

POWER ON RESET	
BASS	2dB
TREBLE	0dB
SURROUND & OUT CONTROL+ EFFECT CONTROL	OFF + FIX + MAX ATTENUATION
SPEAKER ATTENUATION L & R	MUTE
INPUT ATTENUATION	MAX ATTENUATION
INPUT	IN1

Figure 8. PIN: TREBLE-L, TREBLE-R

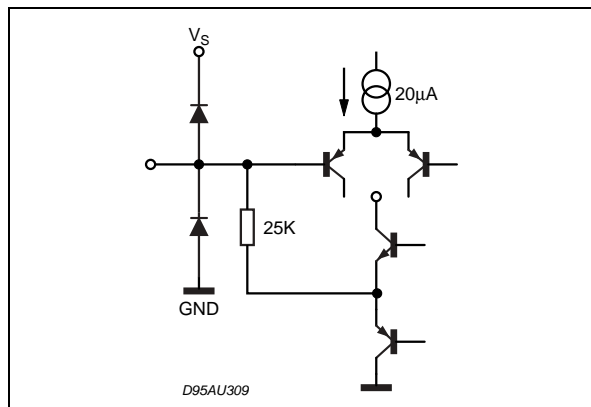

Figure 9. PIN: VOUT REF

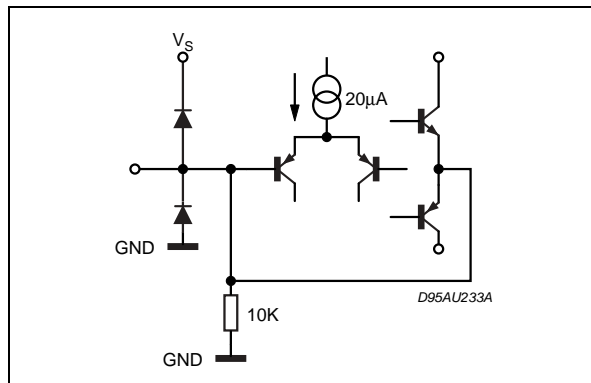

Figure 10. PIN: L-IN, R-IN, L-IN2, R-IN2, L-IN3, R-IN3, L-IN4, R-IN4,

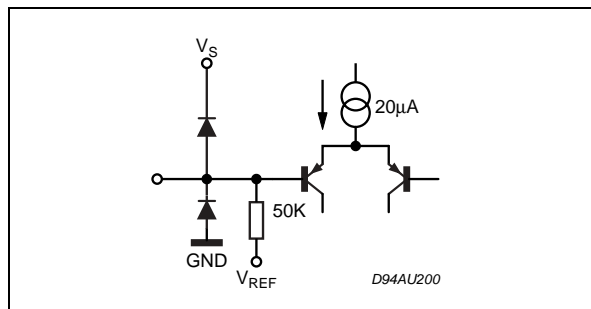

Figure 11. PIN: CREF

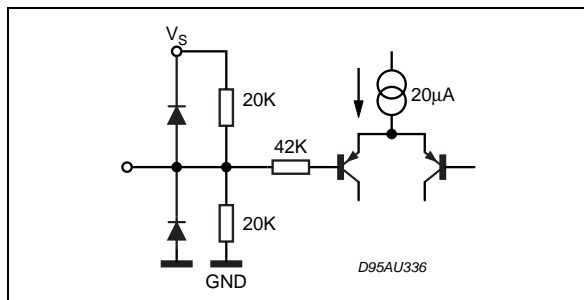

Figure 12. PIN: SCL, SDA

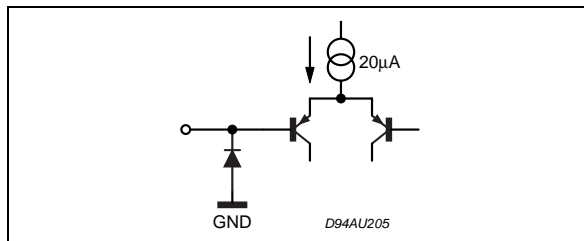

Figure 13. PIN: LP

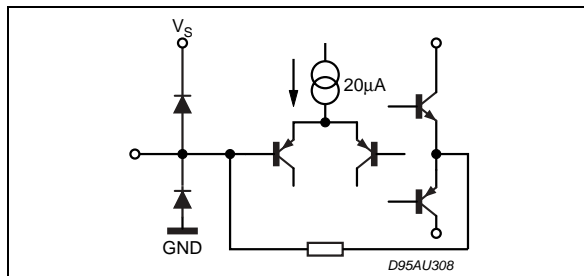

Figure 14. PIN: L-OUT, R-OUT

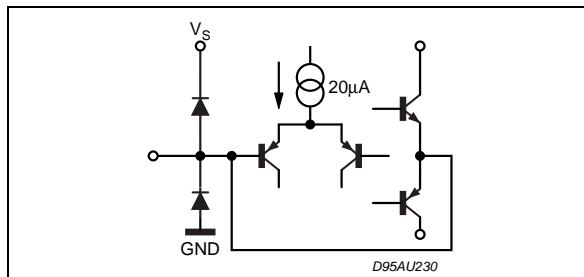

Figure 15. PIN: BASS-LI, BASS-RI

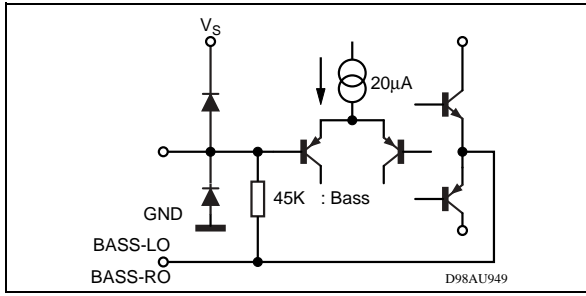

Figure 16. PIN: BASS-LO, BASS-RO

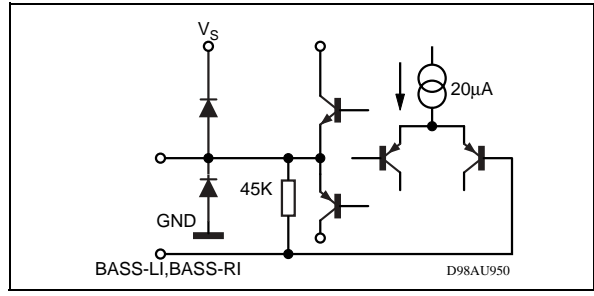

Figure 17. SO-28 Mechanical Data & Package Dimensions

DIM.	mm			inch		
	MIN.	TYP.	MAX.	MIN.	TYP.	MAX.
A			2.65			0.104
a1	0.1		0.3	0.004		0.012
b	0.35		0.49	0.014		0.019
b1	0.23		0.32	0.009		0.013
C		0.5			0.020	
c1	45° (typ.)					
D	17.7		18.1	0.697		0.713
E	10		10.65	0.394		0.419
e		1.27			0.050	
e3		16.51			0.65	
F	7.4		7.6	0.291		0.299
L	0.4		1.27	0.016		0.050
S	8° (max.)					

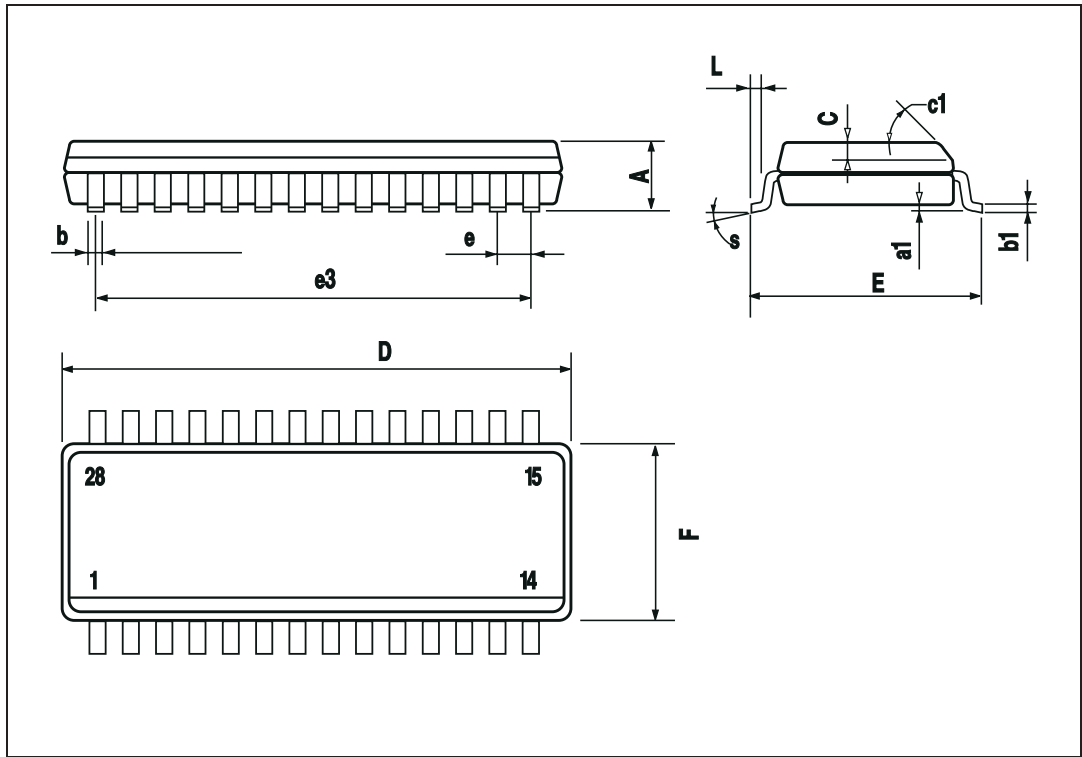
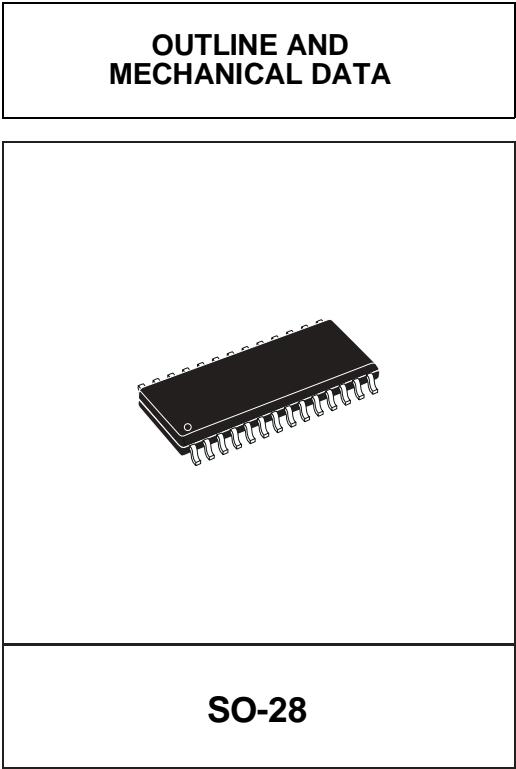
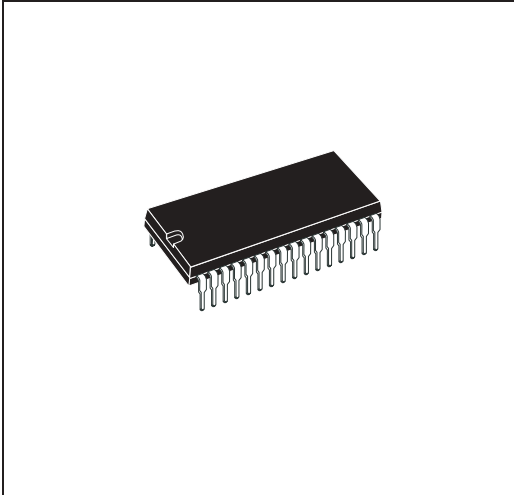

Figure 18. SDIP-32 Mechanical Data & Package Dimensions

DIM.	mm			inch		
	MIN.	TYP.	MAX.	MIN.	TYP.	MAX.
A	3.556	3.759	5.080	0.14	0.147	0.2
A1	0.508			0.020		
A2	3.048	3.556	4.572	0.12	0.14	0.18
B	0.356	0.457	0.584	0.014	0.018	0.023
B1	0.762	1.016	1.397	0.03	0.04	0.055
C	0.203	0.254	0.356	0.008	0.01	0.014
D	27.43	27.94	28.45	1.08	1.1	1.12
E	9.906	10.41	11.05	0.39	0.409	0.433
E1	7.620	8.890	9.398	0.3	0.35	0.37
e		1.778			0.070	
eA		10.16			0.400	
eB			12.70			0.500
L	2.540	3.048	3.810	0.1	0.12	0.15

**OUTLINE AND MECHANICAL DATA**



**SDIP-32  
(Shrink Plastic Dip 32L)**

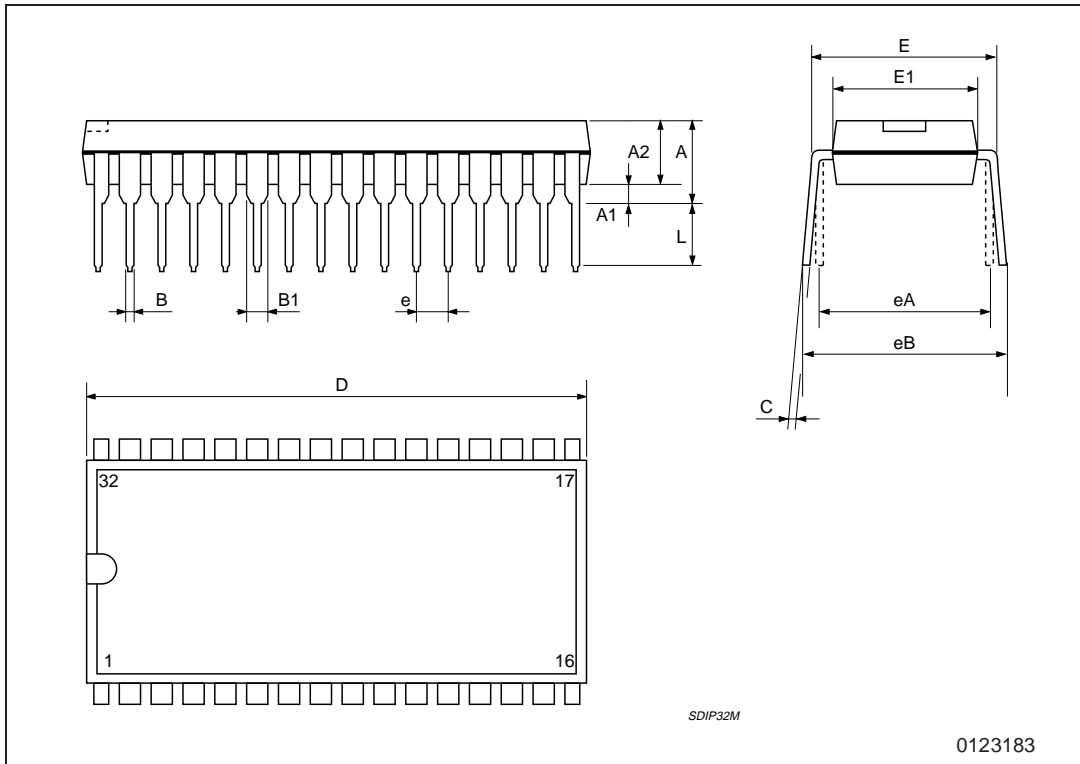

**Table 7. Revision History**

<b>Date</b>	<b>Revision</b>	<b>Description of Changes</b>
January 2001	1	First issue.
June 2004	2	Changed the Style-sheet in compliance to the new "Corporate Technical Publications Design Guide"

Information furnished is believed to be accurate and reliable. However, STMicroelectronics assumes no responsibility for the consequences of use of such information nor for any infringement of patents or other rights of third parties which may result from its use. No license is granted by implication or otherwise under any patent or patent rights of STMicroelectronics. Specifications mentioned in this publication are subject to change without notice. This publication supersedes and replaces all information previously supplied. STMicroelectronics products are not authorized for use as critical components in life support devices or systems without express written approval of STMicroelectronics.

The ST logo is a registered trademark of STMicroelectronics.  
All other names are the property of their respective owners

© 2004 STMicroelectronics - All rights reserved



**STMicroelectronics GROUP OF COMPANIES**

Australia - Belgium - Brazil - Canada - China - Czech Republic - Finland - France - Germany - Hong Kong - India - Israel - Italy - Japan -  
Malaysia - Malta - Morocco - Singapore - Spain - Sweden - Switzerland - United Kingdom - United States

[www.st.com](http://www.st.com)

## Looking for pricing, stock, or lifecycle information?

Click below to explore more details on WIN SOURCE:

-  [View TDA7442D](#) on WIN SOURCE
-  [STMicroelectronics](#) Information

## Optimize Your Supply Chain with WIN SOURCE Solutions

-  Global Sourcing Solution
-  Obsolete Management
-  Cost Control Management
-  Shortage Management
-  Alternative Solution
-  Excess Inventory Management