



THE DATASHEET OF SN65LBC180RSAR



Low-Power RS-485 Line Driver and Receiver Pairs

1 Features

- Designed for high-speed multipoint Data transmission over long cables
- Operate with pulse durations as low as 30 ns
- Low supply current: 5 mA maximum
- Meet or exceed the requirements of ANSI standard RS-485 and ISO 8482:1987(E)
- 3-State outputs for party-line buses
- Common-mode voltage range of -7 V to 12 V
- Thermal shutdown protection prevents driver damage from bus contention
- Positive and negative output current limiting
- Pin compatible with the SN75ALS180

2 Description

The SN55LBC180, SN65LBC180 and SN75LBC180 differential driver and receiver pairs are monolithic integrated circuits designed for bidirectional data communication over long cables that take on the characteristics of transmission lines. They are balanced, or differential, voltage mode devices that meet or exceed the requirements of industry standards ANSI RS-485 and ISO 8482:1987(E). These devices are designed using the TI proprietary LinBiCMOS™ with the low-power consumption of CMOS and the precision and robustness of bipolar transistors in the same circuit.

Package Information

PART NUMBER	PACKAGE ⁽¹⁾	BODY SIZE (NOM)
SN75LBC180 SN65LBC180	N (PDIP)	19.3 mm x 63.5 mm
	D (SOIC)	8.65 mm x 3.91 mm
SN55LBC180	RSA (QFN)	4 mm x 4 mm
	RSA (QFN)	4 mm x 4 mm

(1) For all available packages, see the orderable addendum at the end of the data sheet.

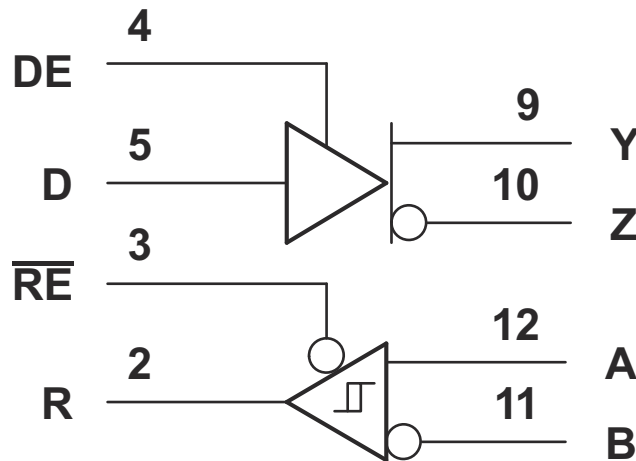

Logic Diagram (positive logic)



Table of Contents

1 Features	1	8 Detailed Description	15
2 Description	1	8.1 Function Tables.....	15
3 Description (Continued)	2	8.2 Schematics of Inputs and Outputs.....	16
4 Revision History	3	9 Application and Implementation	17
5 Pin Configuration and Functions	4	9.1 Application Information.....	17
6 Specifications	5	10 Device and Documentation Support	18
6.1 Absolute Maximum Ratings.....	5	10.1 Receiving Notification of Documentation Updates..	18
6.2 Dissipation Rating Table.....	5	10.2 Support Resources.....	18
6.3 Recommended Operating Conditions.....	5	10.3 Trademarks.....	18
6.4 Thermal Information Table.....	6	10.4 Electrostatic Discharge Caution.....	18
6.5 Driver Section.....	6	10.5 Glossary.....	18
6.6 Receiver Section.....	7	11 Mechanical, Packaging, and Orderable Information	18
6.7 Typical Characteristics.....	9		
7 Parameter Measurement Information	12		

3 Description (Continued)

The SN55LBC180, SN65LBC180 and SN75LBC180 combine a differential line driver and receiver with 3-state outputs and operate from a single 5-V supply. The driver and receiver have active-high and active-low enables, respectively, which can be externally connected to function as a direction control. The driver differential outputs and the receiver differential inputs are connected to separate terminals for full-duplex operation and are designed to present minimum loading to the bus whether disabled or powered off ($V_{CC} = 0$). These parts feature a wide common-mode voltage range making them suitable for point-to-point or multipoint data-bus applications.

The devices also provide positive and negative output-current limiting and thermal shutdown for protection from line fault conditions. The line driver shuts down at a junction temperature of approximately 172°C.

The SN75LBC180 is characterized for operation over the commercial temperature range of 0°C to 70°C. The SN65LBC180 is characterized over the industrial temperature range of –40°C to 85°C.

The SN55LBC180 is characterized for operation over the military temperature range of –55°C to 125°C.

4 Revision History

NOTE: Page numbers for previous revisions may differ from page numbers in the current version.

Changes from Revision H (June 2022) to Revision I (October 2022) Page

- Changed RSA (QFN) values in the *Thermal Information Table*6

Changes from Revision G (April 2009) to Revision H (June 2022) Page

- Changed the Ordering Information Table to the *Package Information* table..... 1
- Added the *Pin Configuration and Functions* 4
- Added the *Thermal Information Table*6
- Fixed the typo in the unit for the Receiver enable I_{IH} to change the unit from A to μ A..... 7
- Updated [Figure 6-1](#), [Figure 6-2](#), and [Figure 6-3](#), limiting the x-axis to a maximum of 70 mA driver output current.....9
- Updated [Figure 9-1](#) to remove legacy terminology 17

Changes from Revision F (March 2009) to Revision G (April 2009) Page

- Added 3 ESD rows to the *Absolute Maximum Ratings*5

Changes from Revision E (February 2006) to Revision F (March 2009) Page

- Changed Differential to RS-485 in the data sheet title..... 1
- Added device number SN55LBC180 1
- Changed the word *both* to *these* 1
- Added the Ordering Information Table..... 1
- Changed the *Description (Continued)* section..... 2
- Changed and moved the *Function Tables* from the front page to the *Description (Continued)* section..... 2
- Deleted condition, moved cross reference..... 5
- Added all symbols in text that were not appearing in the PDF..... 5
- Deleted T_A row from the *Absolute Maximum Ratings* 5
- Added the last column to *Dissipation Rating Table* 5
- Added a row to T_A in the *Recommended Operating Conditions* for SN55LBC180..... 5
- Added SN55LB180 to the $|V_{OD}|$ row..... 6
- Change: moved 5 max values to the min column (-1.5, -50, -100, -0.8, -0.8)..... 7
- Added the *Switching Characteristics: SN55LBC180* table 8
- Changed moved schematics to the Typical Characteristics section..... 16

5 Pin Configuration and Functions

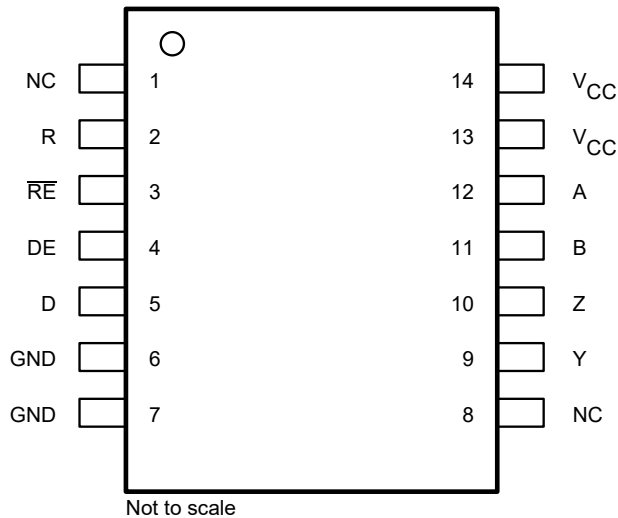

**Figure 5-1. D OR N Package (SOIC)
(Top View)**

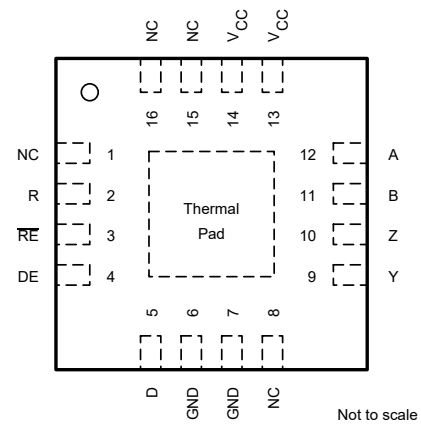

**Figure 5-2. RSA Package (QFN)
(Top View)**

Table 5-1. Pin Functions

PIN NAME	PIN NO		TYPE ⁽¹⁾	DESCRIPTION
	D Or N	RSA		
NC	1	1	NC	No internal connection
R	2	2	O	Receiver output
RE	3	3	I	Receiver enable input. Active low.
DE	4	4	I	Driver enable input. Active high
D	5	5	I	Driver input pin
GND	6, 7	6, 7	G	Ground connection. Pins 6 and 7 are connected together internally.
NC	8	8	NC	No internal connection
Y	9	9	O	Bus output port (complementary to Z)
Z	10	10	O	Bus output port (complementary to Y)
B	11	11	I	Bus input port (complementary to A)
A	12	12	I	Bus input port (complementary to B)
V _{CC}	13, 14	13, 14	P	Supply input pins. Pins 13 and 14 are connected together internally.
NC	N/A	15, 16	NC	No internal connection

(1) Signal Types: I = Input, O = Output, P= Power input,

6 Specifications

6.1 Absolute Maximum Ratings

See note (1)

			UNIT	
V _{CC}	Supply voltage range (2)	-0.3 to 7	V	
V _{BUS}	Bus voltage range (A, B, Y, Z)(2)	-10 to 15	V	
	Voltage range at D, R, DE, \overline{RE} (2)	-0.3 to V _{CC} + 0.5	V	
	Continuous total power dissipation(3)	Internally limited		
	Total power dissipation	See Dissipation Rating Table		
T _{stg}	Storage temperature range	-65 to 150	°C	
I _O	Receiver output current range	-50 to 50	mA	
ESD	Electrostatic discharge	HBM (Human Body Model) EIA/JESD22-A114	±4	kV
		MM (Machine Model) EIA/JESD22-A115	400	V
		CDM (Charge Device Model) EIA/JESD22-C101	1.5	kV

- (1) Stresses beyond those listed under *absolute maximum ratings* may cause permanent damage to the device. These are stress ratings only, and functional operation of the device at these or any other conditions beyond those indicated under *recommended operating conditions* is not implied. Exposure to absolute-maximum-rated conditions for extended periods may affect device reliability.
- (2) All voltage values are with respect to GND.
- (3) The maximum operating junction temperature is internally limited. Use the dissipation rating table to operate below this temperature.

6.2 Dissipation Rating Table

PACKAGE(1)	T _A ≤ 25°C POWER RATING	DERATING FACTOR ABOVE T _A = 25°C	T _A = 70°C POWER RATING	T _A = 85°C POWER RATING	T _A = 125°C POWER RATING
D	950 mW	7.6 mW/°C	608 mW	494 mW	—
N	1150 mW	9.2 mW/°C	736 mW	598 mW	—
RSA	3333 mW	26.67 mW/°C	2133 mW	1733 mW	400 mW

- (1) For the most current package and ordering information, see the Package Option Addendum at the end of this document, or see the TI Web site at www.ti.com.

6.3 Recommended Operating Conditions

		MIN	NOM	MAX	UNIT	
V _{CC}	Supply voltage	4.75	5	5.25	V	
V _{IH}	High-level input voltage	D, DE, and \overline{RE}		2	V	
V _{IL}	Low-level input voltage	D, DE, and \overline{RE}		0.8	V	
V _{ID}	Differential input voltage			-6(1)	6	V
V _O , V _I , or V _{IC}	Voltage at any bus terminal (separately or common mode)	A, B, Y, or Z		-7(1)	12	V
I _{OH}	High-level output current	Y or Z		-60	mA	
		R		-8		
I _{OL}	Low-level output current	Y or Z		60	mA	
		R		8		
T _A	Operating free-air temperature	SN55LBC180		-55	125	°C
		SN65LBC180		-40	85	
		SN75LBC180		0	70	

- (1) The algebraic convention where the least positive (more negative) limit is designated minimum, is used in this data sheet for the differential input voltage, voltage at any bus terminal, operating temperature, input threshold voltage, and common-mode output voltage.

6.4 Thermal Information Table

THERMAL METRIC ⁽¹⁾		D (SOIC)	N (PDIP)	RSA (QFN)	UNIT
		14 Pins	14 Pins	16 Pins	
$R_{\theta JA}$	Junction-to-ambient thermal resistance	93.2	53.4	38.7	°C/W
$R_{\theta JC(top)}$	Junction-to-case (top) thermal resistance	47.5	40.0	35.6	°C/W
$R_{\theta JB}$	Junction-to-board thermal resistance	49.4	33.2	17.5	°C/W
Ψ_{JT}	Junction-to-top characterization parameter	11.2	19.0	1.1	°C/W
Ψ_{JB}	Junction-to-board characterization parameter	48.9	32.9	17.5	°C/W
$R_{\theta JC(bot)}$	Junction-to-case (bottom) thermal resistance	n/a	n/a	7.9	°C/W

(1) For more information about traditional and new thermal metrics, see the [Semiconductor and IC package thermal metrics](#) application report.

6.5 Driver Section

6.5.1 Electrical Characteristics

over recommended operating conditions (unless otherwise noted)

PARAMETER		TEST CONDITIONS		MIN	TYP ⁽¹⁾	MAX	UNIT
V_{IK}	Input clamp voltage	$I_I = -18 \text{ mA}$				-1.5	V
$ V_{OD} $	Differential output voltage magnitude ⁽²⁾	$R_L = 54 \Omega$, See Figure 7-1	SN55LBC180	1	2.5	5	V
			SN65LBC180	1.1	2.5	5	
			SN75LBC180	1.5	2.5	5	
		$R_L = 60 \Omega$, See Figure 7-2	SN55LBC180	1	2.5	5	
			SN65LBC180	1.1	2	5	
			SN75LBC180	1.5	2	5	
$\Delta V_{OD} $	Change in magnitude of differential output voltage ⁽³⁾	See Figure 7-1 and Figure 7-2				±0.2	V
V_{OC}	Common-mode output voltage			1	2.5	3	V
$\Delta V_{OC} $	Change in magnitude of common-mode output voltage ⁽³⁾	$R_L = 54 \Omega$,	See Figure 7-1			±0.2	V
I_O	Output current with power off	$V_{CC} = 0$,	$V_O = -7 \text{ V to } 12 \text{ V}$			±100	µA
I_{OZ}	High-impedance-state output current	$V_O = -7 \text{ V to } 12 \text{ V}$				±100	µA
I_{IH}	High-level input current	$V_I = 2.4 \text{ V}$				100	µA
I_{IL}	Low-level input current	$V_I = 0.4 \text{ V}$				100	µA
I_{OS}	Short-circuit output current	$-7 \text{ V} \leq V_O \leq 12 \text{ V}$				±250	mA
I_{CC}	Supply current	Receiver disabled	Outputs enabled			5	mA
			Outputs disabled			3	

(1) All typical values are at $V_{CC} = 5 \text{ V}$ and $T_A = 25^\circ\text{C}$.

(2) The minimum V_{OD} specification may not fully comply with ANSI RS-485 at operating temperatures below 0°C . System designers should take the possibly lower output signal into account in determining the maximum signal-transmission distance.

(3) $\Delta|V_{OD}|$ and $\Delta|V_{OC}|$ are the changes in the steady-state magnitude of V_{OD} and V_{OC} , respectively, that occur when the input is changed from a high level to a low level.

6.5.2 Switching Characteristics

 $V_{CC} = 5\text{ V}$, $T_A = 25^\circ\text{C}$

PARAMETER		TEST CONDITIONS		MIN	TYP	MAX	UNIT
$t_{d(OD)}$	Differential output delay time	$R_L = 54\ \Omega$,	See Figure 7-3	7	12	18	ns
$t_{t(OD)}$	Differential output transition time			5	10	20	ns
t_{PZH}	Output enable time to high level	$R_L = 110\ \Omega$,	See Figure 7-4			35	ns
t_{PZL}	Output enable time to low level	$R_L = 110\ \Omega$,	See Figure 7-5			35	ns
t_{PHZ}	Output disable time from high level	$R_L = 110\ \Omega$,	See Figure 7-4			50	ns
t_{PLZ}	Output disable time from low level	$R_L = 110\ \Omega$,	See Figure 7-5			35	ns

6.5.3 Switching Characteristics: SN55LBC180

 $V_{CC} = 5\text{ V}$, $T_A = 25^\circ\text{C}$

PARAMETER		TEST CONDITIONS		MIN	TYP	MAX	UNIT
$t_{d(OD)}$	Differential output delay time	$R_L = 54\ \Omega$,	See Figure 7-3		15		ns
$t_{t(OD)}$	Differential output transition time				21		ns
t_{PZH}	Output enable time to high level	$R_L = 110\ \Omega$,	See Figure 7-4		32		ns
t_{PHZ}	Output disable time from high level				55		
t_{PZL}	Output enable time to low level	$R_L = 110\ \Omega$,	See Figure 7-5		32		ns
t_{PLZ}	Output disable time from low level				20		

6.6 Receiver Section

6.6.1 Electrical Characteristics

over recommended operating conditions (unless otherwise noted)

PARAMETER		TEST CONDITIONS		MIN	TYP	MAX	UNIT
V_{IT+}	Positive-going input threshold voltage	$I_O = -8\text{ mA}$				0.2	V
V_{IT-}	Negative-going input threshold voltage	$I_O = 8\text{ mA}$		-0.2			V
V_{hys}	Hysteresis voltage ($V_{IT+} - V_{IT-}$)				45		mV
V_{IK}	Enable-input clamp voltage	$I_I = -18\text{ mA}$		-1.5			V
V_{OH}	High-level output voltage	$V_{ID} = 200\text{ mV}$,	$I_{OH} = -8\text{ mA}$	3.5	4.5		V
V_{OL}	Low-level output voltage	$V_{ID} = -200\text{ mV}$,	$I_{OL} = 8\text{ mA}$		0.3	0.5	V
I_{OZ}	High-impedance-state output current	$V_O = 0\text{ V to }V_{CC}$				± 20	μA
I_{IH}	High-level enable-input current	$V_{IH} = 2.4\text{ V}$		-50			μA
I_{IL}	Low-level enable-input current	$V_{IL} = 0.4\text{ V}$		-100			μA
I_I	Bus input current	$V_I = 12\text{ V}$, $V_{CC} = 5\text{ V}$,	Other input at 0 V		0.7	1	mA
		$V_I = 12\text{ V}$, $V_{CC} = 0\text{ V}$,	Other input at 0 V		0.8	1	
		$V_I = -7\text{ V}$, $V_{CC} = 5\text{ V}$,	Other input at 0 V	-0.8	-0.5		
		$V_I = -7\text{ V}$, $V_{CC} = 0\text{ V}$,	Other input at 0 V	-0.8	-0.5		
I_{CC}	Supply current	Driver disabled	Outputs enabled			5	mA
			Outputs disabled			3	

6.6.2 Switching Characteristics

$V_{CC} = 5\text{ V}$, $T_A = 25^\circ\text{C}$

PARAMETER		TEST CONDITIONS	MIN	TYP	MAX	UNIT
t_{PHL}	Propagation delay time, high- to low-level output	$V_{ID} = -1.5\text{ V to }1.5\text{ V}$, See Figure 7-6	11	22	33	ns
t_{PLH}	Propagation delay time, low- to high-level output		11	22	33	ns
$t_{sk(p)}$	Pulse skew ($ t_{PHL} - t_{PLH} $)		3	6	ns	
t_t	Transition time		5	8	ns	
t_{PZH}	Output enable time to high level	See Figure 7-7			35	ns
t_{PZL}	Output enable time to low level				30	ns
t_{PHZ}	Output disable time from high level				35	ns
t_{PLZ}	Output disable time from low level				30	ns

6.6.3 Switching Characteristics: SN55LBC180

$V_{CC} = 5\text{ V}$, $T_A = 25^\circ\text{C}$

PARAMETER		TEST CONDITIONS	MIN	TYP	MAX	UNIT
t_{PHL}	Propagation delay time, high- to low-level output	$V_{ID} = -1.5\text{ V to }1.5\text{ V}$, See Figure 7-6		26		ns
t_{PLH}	Propagation delay time, low- to high-level output			23		ns
$t_{sk(p)}$	Pulse skew ($ t_{PHL} - t_{PLH} $)			3		ns
$t_{sk(p)t}$	Transition time			4		ns
t_{PZH}	Output enable time to high level	See Figure 7-4		30		ns
t_{PHZ}	Output disable time from high level			26		ns
t_{PZL}	Output enable time to low level			30		ns
t_{PLZ}	Output disable time from low level			30		ns

6.7 Typical Characteristics

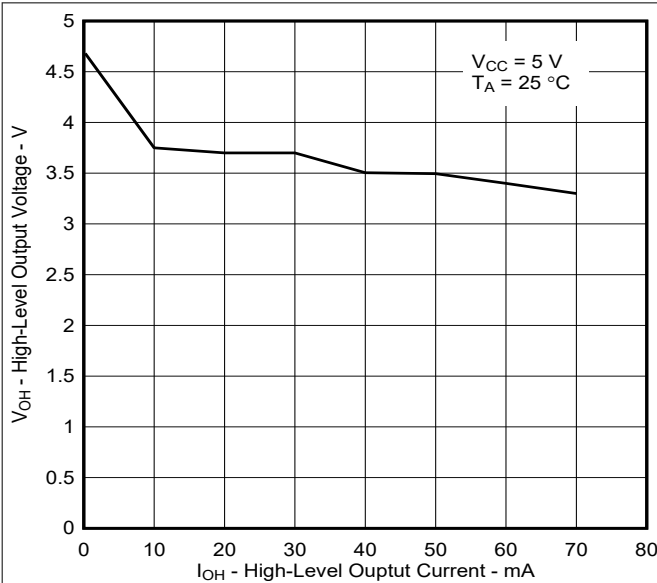

Figure 6-1. Driver High-Level Output Voltage vs High-Level Output Current

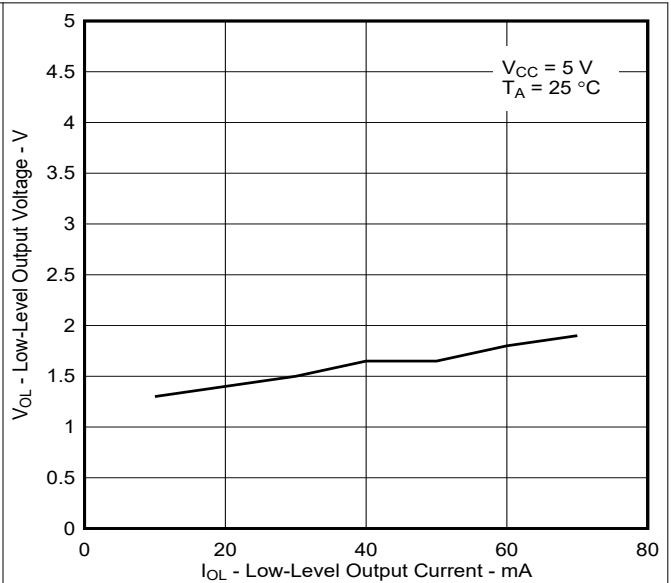

Figure 6-2. Driver Low-Level Output Voltage vs Low-Level Output Current

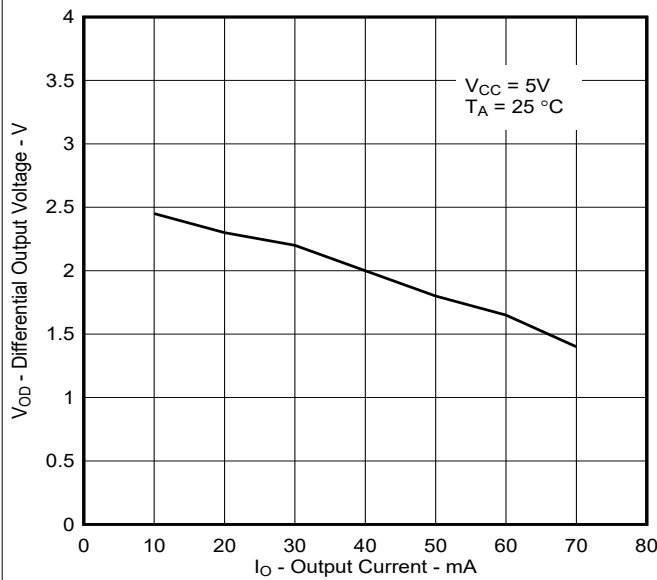

Figure 6-3. Driver Differential Output Voltage vs Output Current

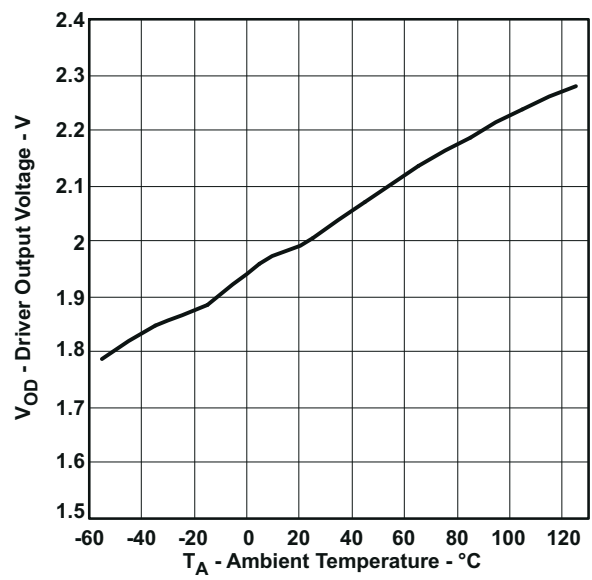

Figure 6-4. Driver Differential Output Voltage vs Free-Air Temperature

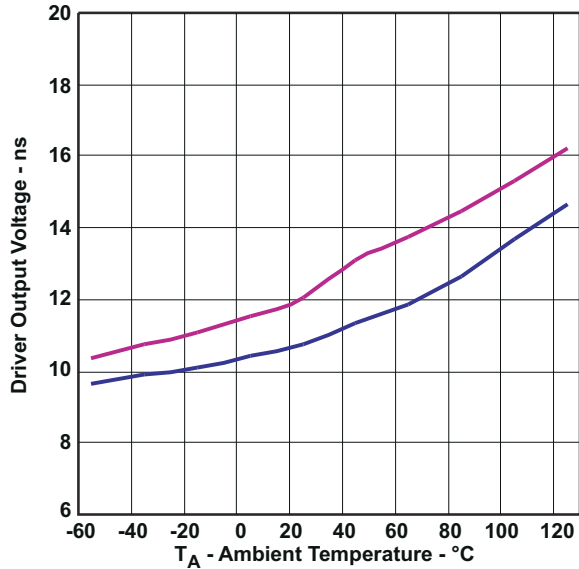

Figure 6-5. Driver Differential Delay Times vs Free-Air Temperature

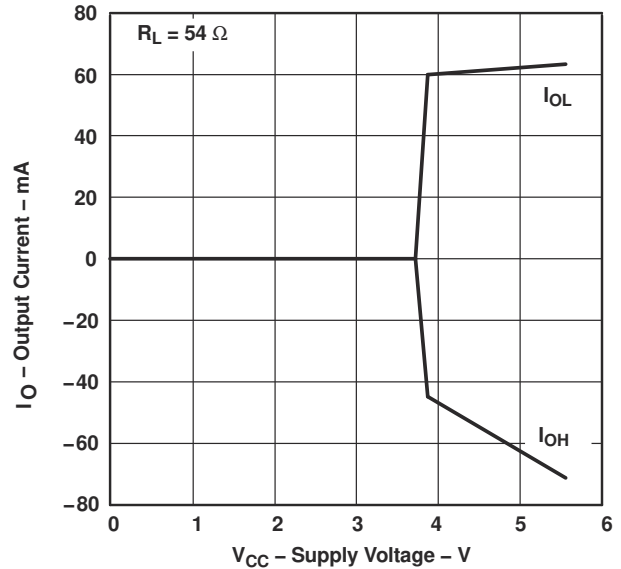

Figure 6-6. Driver Output Current vs Supply Voltage

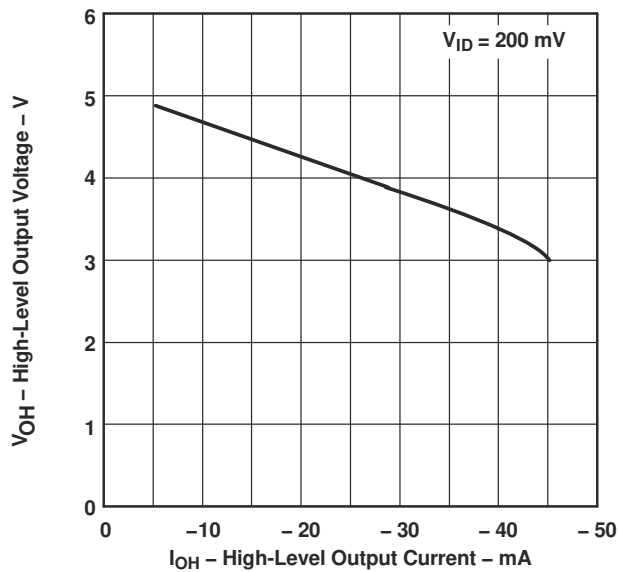

Figure 6-7. Receiver High-Level Output Voltage vs High-Level Output Current

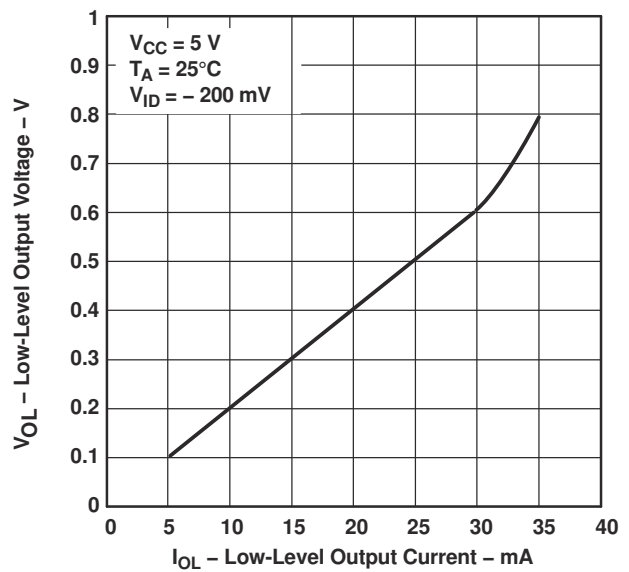

Figure 6-8. Receiver Low-Level Output Voltage vs Low-Level Output Current

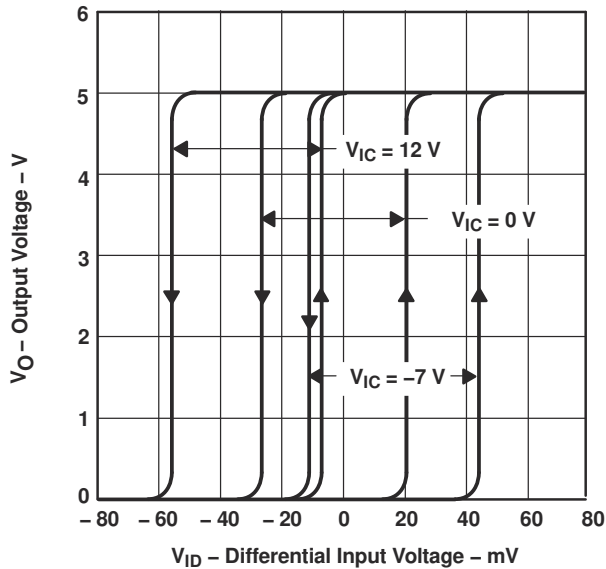

Figure 6-9. Receiver Output Voltage vs Differential Input Voltage

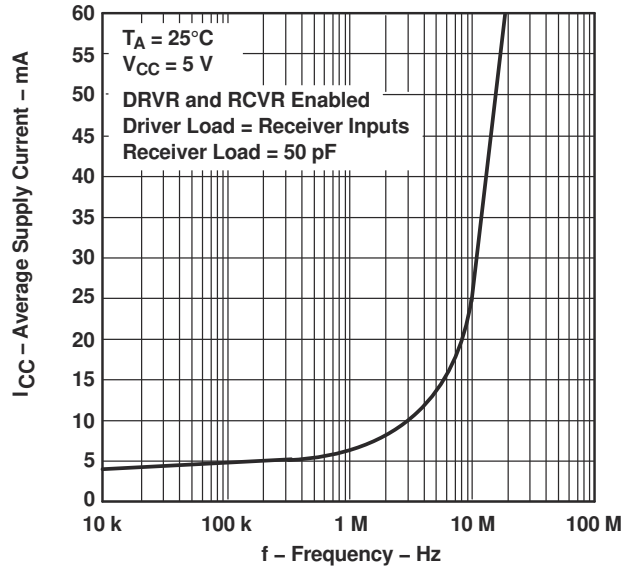

Figure 6-10. Average Supply Current vs Frequency

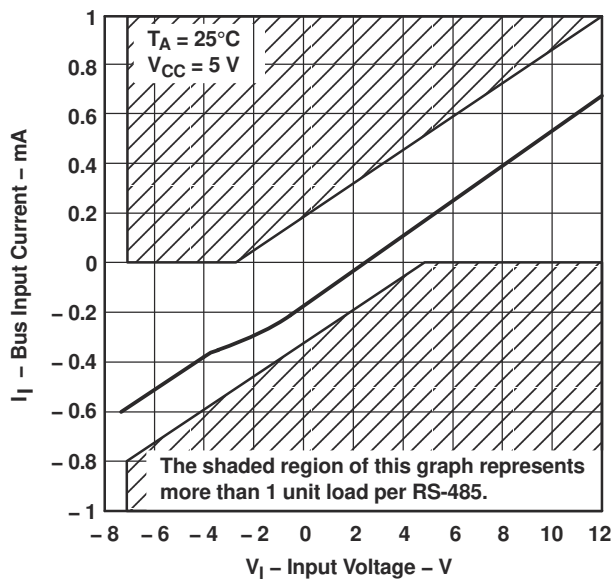

Figure 6-11. Receiver Bus Input Current vs Input Voltage (Complementary Input at 0 V)

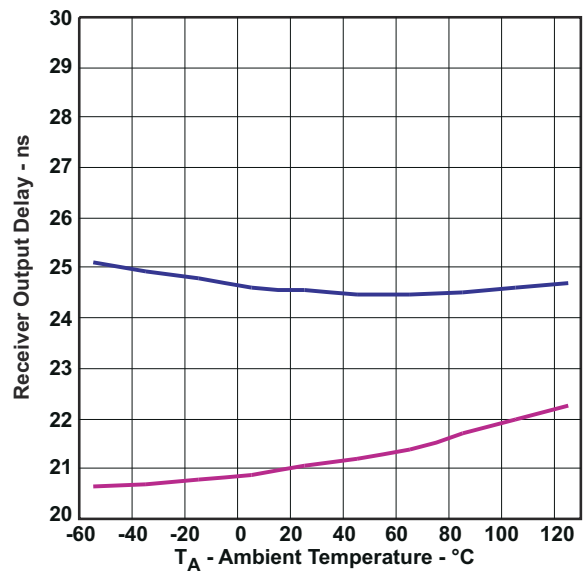

Figure 6-12. Receiver Propagation DELAY T_I vs Free-Air Temperature

7 Parameter Measurement Information

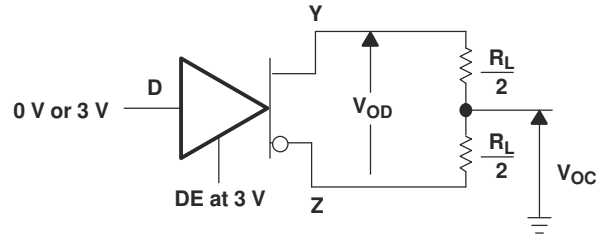

Figure 7-1. Differential and Common-Mode Output Voltages

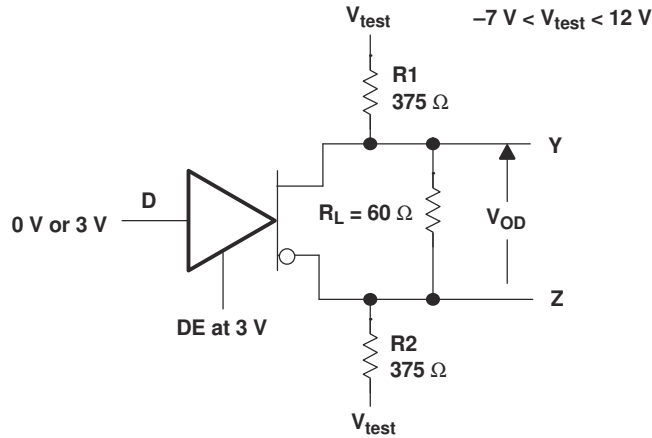
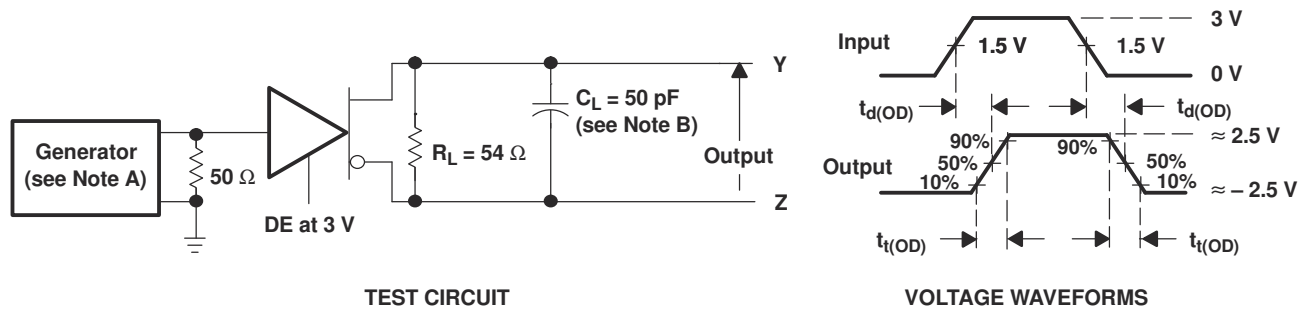

Figure 7-2. Driver V_{OD} Test Circuit



NOTES: A. The input pulse is supplied by a generator having the following characteristics: PRR > 1 MHz, 50% duty cycle, $t_r \leq 6$ ns, $t_f \leq 6$ ns, $Z_O = 50 \Omega$.
 B. C_L includes probe and jig capacitance.

Figure 7-3. Driver Test Circuit and Differential Output Delay and Transition Time Voltage Waveforms

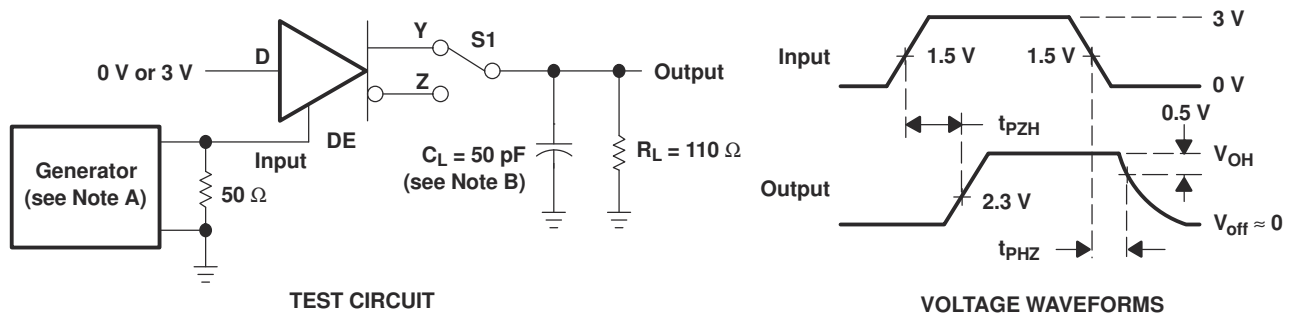

Figure 7-4. Driver Test Circuit and Enable and Disable Time Waveforms

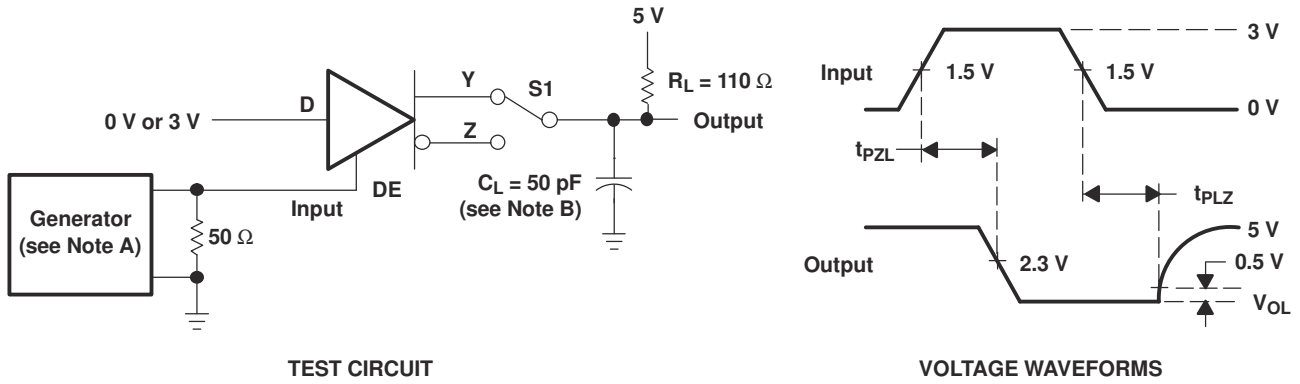
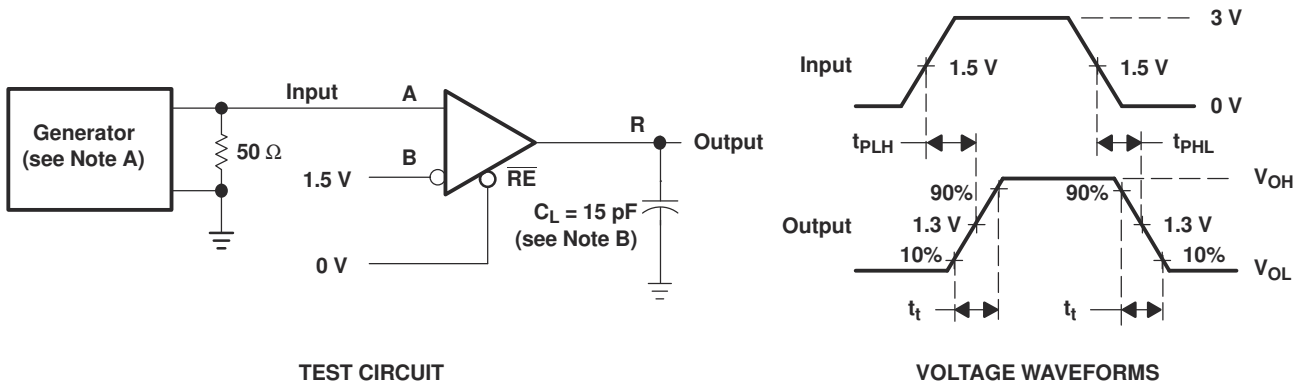
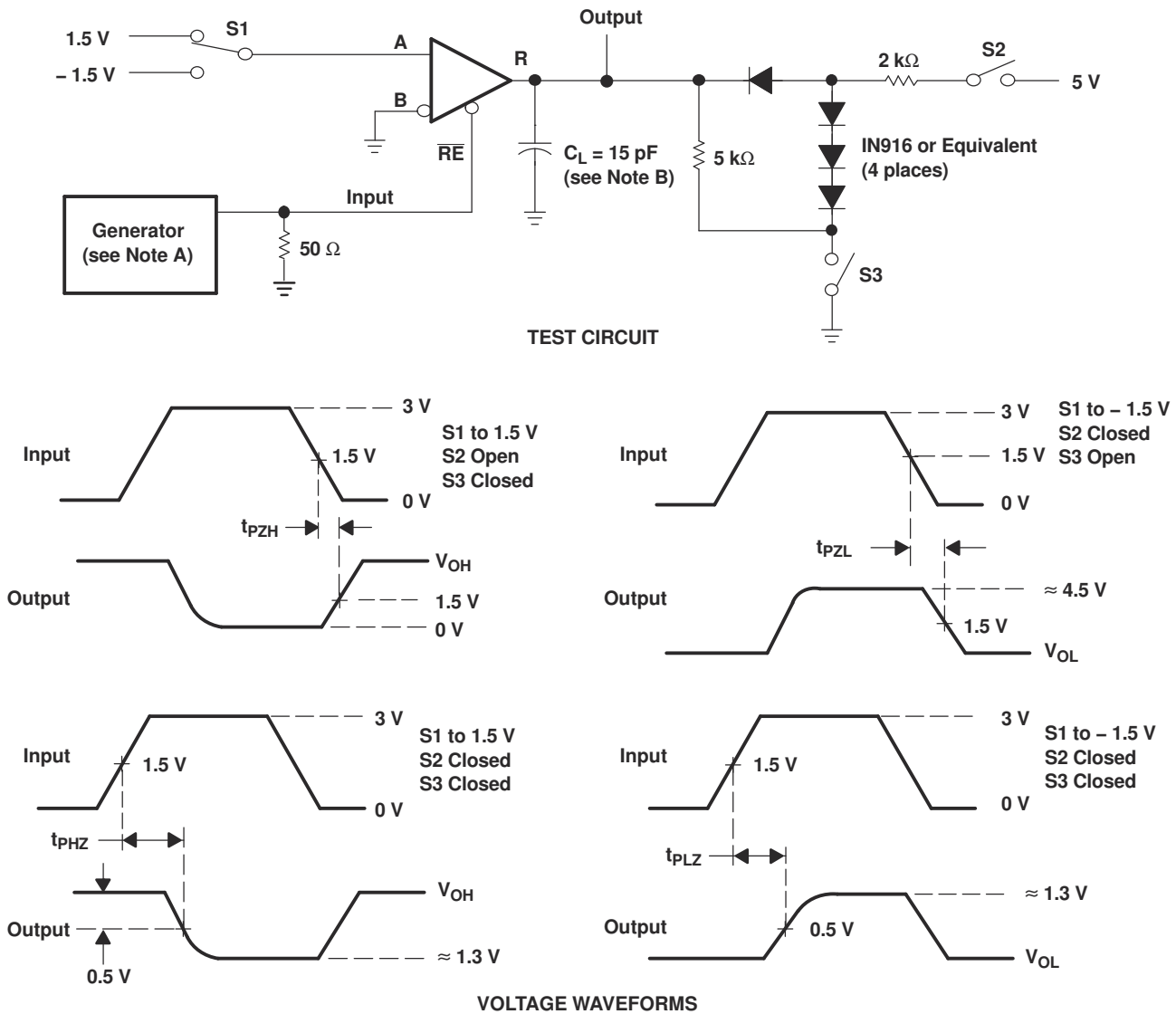

Figure 7-5. Driver Test Circuit and Enable and Disable Time Voltage Waveforms



- NOTES: A. The input pulse is supplied by a generator having the following characteristics: PRR \leq 1 MHz, 50% duty cycle, $t_r \leq$ 6 ns, $t_f \leq$ 6 ns, $Z_O = 50 \Omega$.
 B. C_L includes probe and jig capacitance.

Figure 7-6. Receiver Test Circuit and Propagation Delay Time Voltage Waveforms



- NOTES: A. The input pulse is supplied by a generator having the following characteristics: $PRR \leq 1$ MHz, 50% duty cycle, $t_r \leq 6$ ns, $t_f \leq 6$ ns, $Z_O = 50 \Omega$.
 B. C_L includes probe and jig capacitance.

Figure 7-7. Receiver Output Enable and Disable Times

8 Detailed Description

8.1 Function Tables

Table 8-1. DRIVER

INPUT D ⁽¹⁾	ENABLE DE	OUTPUTS	
		Y	Z
H	H	H	L
L	H	L	H
X	L	Z	Z

(1) H = high level, L = low level, ? = Indeterminate, X = irrelevant,
Z = high impedance (off)

Table 8-2. RECEIVER

DIFFERENTIAL INPUTS A-B	ENABLE RE	OUTPUT R	
		Y	Z
$V_{ID} \geq 0.2\text{ V}$	L	H	
$-0.2\text{ V} < V_{ID} < 0.2\text{ V}$	L	?	
$V_{ID} \leq -0.2\text{ V}$	L	L	
X	H	Z	
Open circuit	L	H	

8.2 Schematics of Inputs and Outputs

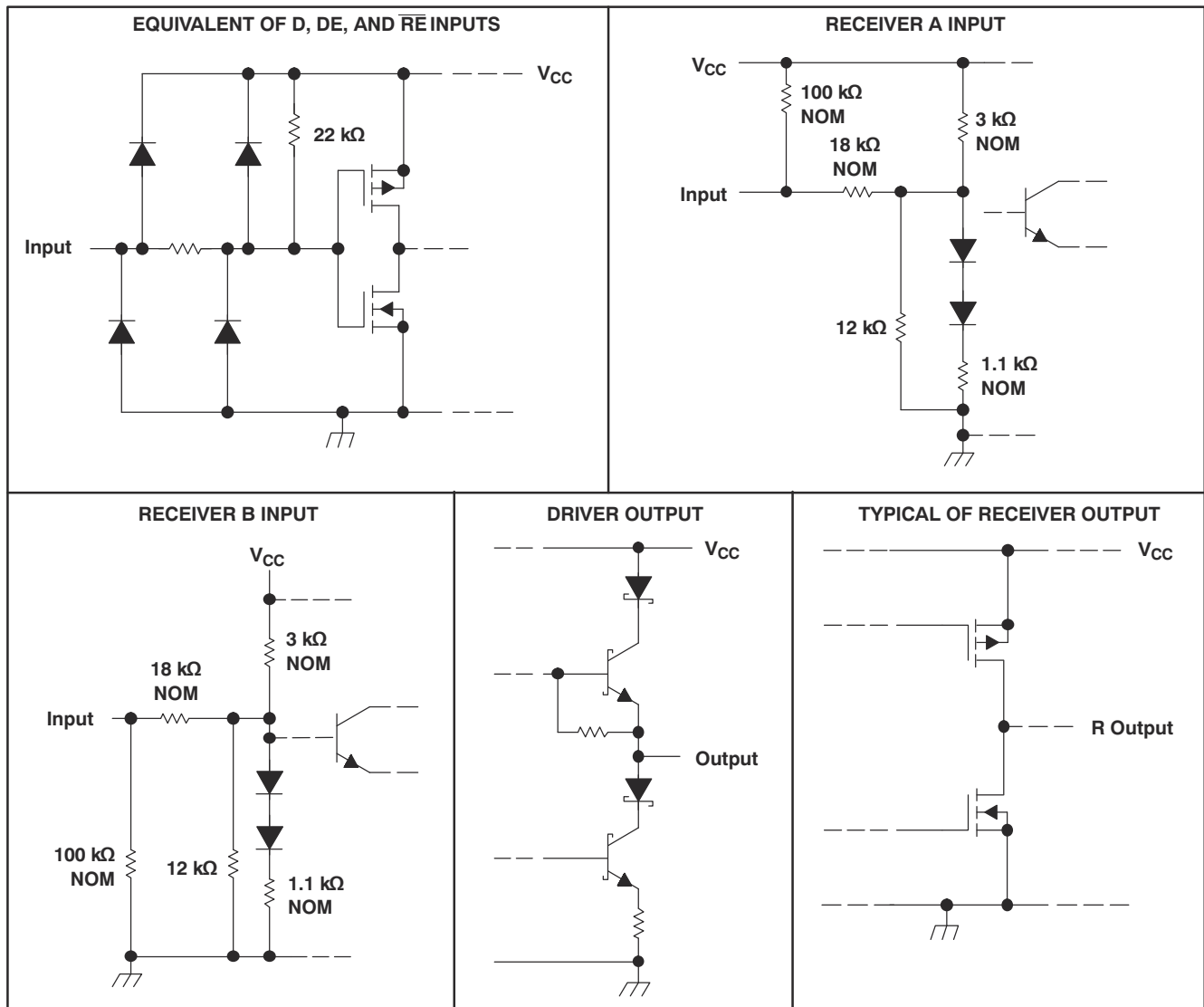

9 Application and Implementation

Note

Information in the following applications sections is not part of the TI component specification, and TI does not warrant its accuracy or completeness. TI's customers are responsible for determining suitability of components for their purposes, as well as validating and testing their design implementation to confirm system functionality.

9.1 Application Information

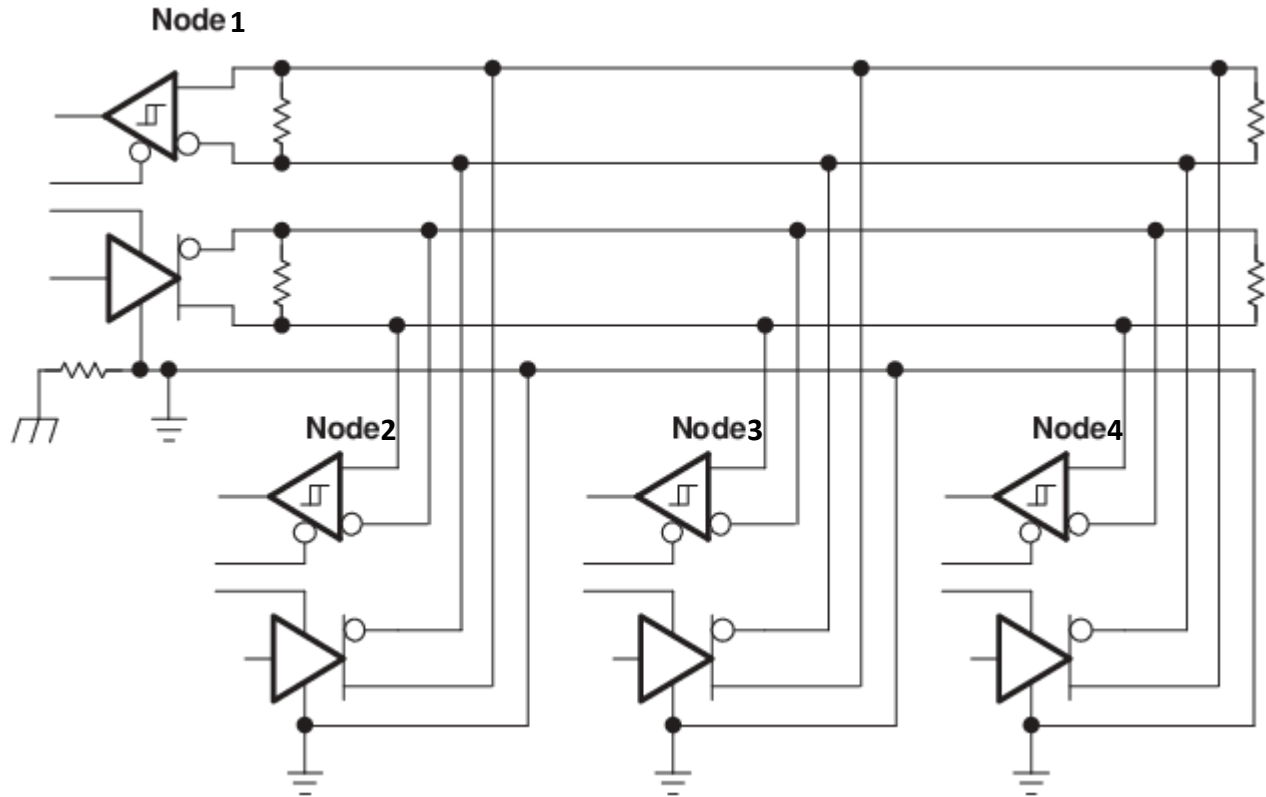

Figure 9-1. Full Duplex Application Circuit

10 Device and Documentation Support

10.1 Receiving Notification of Documentation Updates

To receive notification of documentation updates, navigate to the device product folder on ti.com. Click on *Subscribe to updates* to register and receive a weekly digest of any product information that has changed. For change details, review the revision history included in any revised document.

10.2 Support Resources

TI E2E™ [support forums](#) are an engineer's go-to source for fast, verified answers and design help — straight from the experts. Search existing answers or ask your own question to get the quick design help you need.

Linked content is provided "AS IS" by the respective contributors. They do not constitute TI specifications and do not necessarily reflect TI's views; see TI's [Terms of Use](#).

10.3 Trademarks

LinBiCMOS™ is a trademark of Texas Instruments.

TI E2E™ is a trademark of Texas Instruments.

All trademarks are the property of their respective owners.

10.4 Electrostatic Discharge Caution



This integrated circuit can be damaged by ESD. Texas Instruments recommends that all integrated circuits be handled with appropriate precautions. Failure to observe proper handling and installation procedures can cause damage.

ESD damage can range from subtle performance degradation to complete device failure. Precision integrated circuits may be more susceptible to damage because very small parametric changes could cause the device not to meet its published specifications.

10.5 Glossary

[TI Glossary](#) This glossary lists and explains terms, acronyms, and definitions.

11 Mechanical, Packaging, and Orderable Information

The following pages include mechanical, packaging, and orderable information. This information is the most current data available for the designated devices. This data is subject to change without notice and revision of this document. For browser-based versions of this data sheet, refer to the left-hand navigation.

PACKAGING INFORMATION

Orderable Device	Status (1)	Package Type	Package Drawing	Pins	Package Qty	Eco Plan (2)	Lead finish/ Ball material (6)	MSL Peak Temp (3)	Op Temp (°C)	Device Marking (4/5)	Samples
SN55LBC180RSAR	ACTIVE	QFN	RSA	16	3000	RoHS & Green	NIPDAU	Level-2-260C-1 YEAR	-55 to 125	SN55 LBC180	Samples
SN65LBC180DR	ACTIVE	SOIC	D	14	2500	RoHS & Green	NIPDAU	Level-1-260C-UNLIM	-40 to 85	6LB180	Samples
SN65LBC180DRG4	ACTIVE	SOIC	D	14	2500	RoHS & Green	NIPDAU	Level-1-260C-UNLIM	-40 to 85	6LB180	Samples
SN65LBC180N	ACTIVE	PDIP	N	14	25	RoHS & Green	NIPDAU	N / A for Pkg Type	-40 to 85	SN65LBC180N	Samples
SN65LBC180RSAR	ACTIVE	QFN	RSA	16	3000	RoHS & Green	NIPDAU	Level-2-260C-1 YEAR	-40 to 85	BL180	Samples
SN75LBC180N	ACTIVE	PDIP	N	14	25	RoHS & Green	NIPDAU	N / A for Pkg Type	0 to 70	SN75LBC180N	Samples

(1) The marketing status values are defined as follows:

ACTIVE: Product device recommended for new designs.

LIFEBUY: TI has announced that the device will be discontinued, and a lifetime-buy period is in effect.

NRND: Not recommended for new designs. Device is in production to support existing customers, but TI does not recommend using this part in a new design.

PREVIEW: Device has been announced but is not in production. Samples may or may not be available.

OBSOLETE: TI has discontinued the production of the device.

(2) **RoHS:** TI defines "RoHS" to mean semiconductor products that are compliant with the current EU RoHS requirements for all 10 RoHS substances, including the requirement that RoHS substance do not exceed 0.1% by weight in homogeneous materials. Where designed to be soldered at high temperatures, "RoHS" products are suitable for use in specified lead-free processes. TI may reference these types of products as "Pb-Free".

RoHS Exempt: TI defines "RoHS Exempt" to mean products that contain lead but are compliant with EU RoHS pursuant to a specific EU RoHS exemption.

Green: TI defines "Green" to mean the content of Chlorine (Cl) and Bromine (Br) based flame retardants meet JS709B low halogen requirements of <=1000ppm threshold. Antimony trioxide based flame retardants must also meet the <=1000ppm threshold requirement.

(3) MSL, Peak Temp. - The Moisture Sensitivity Level rating according to the JEDEC industry standard classifications, and peak solder temperature.

(4) There may be additional marking, which relates to the logo, the lot trace code information, or the environmental category on the device.

(5) Multiple Device Markings will be inside parentheses. Only one Device Marking contained in parentheses and separated by a "~" will appear on a device. If a line is indented then it is a continuation of the previous line and the two combined represent the entire Device Marking for that device.

(6) Lead finish/Ball material - Orderable Devices may have multiple material finish options. Finish options are separated by a vertical ruled line. Lead finish/Ball material values may wrap to two lines if the finish value exceeds the maximum column width.

Important Information and Disclaimer: The information provided on this page represents TI's knowledge and belief as of the date that it is provided. TI bases its knowledge and belief on information provided by third parties, and makes no representation or warranty as to the accuracy of such information. Efforts are underway to better integrate information from third parties. TI has taken and continues to take reasonable steps to provide representative and accurate information but may not have conducted destructive testing or chemical analysis on incoming materials and chemicals. TI and TI suppliers consider certain information to be proprietary, and thus CAS numbers and other limited information may not be available for release.

In no event shall TI's liability arising out of such information exceed the total purchase price of the TI part(s) at issue in this document sold by TI to Customer on an annual basis.

OTHER QUALIFIED VERSIONS OF SN55LBC180, SN75LBC180 :

- Catalog : [SN75LBC180](#)
- Military : [SN55LBC180](#)

NOTE: Qualified Version Definitions:

- Catalog - TI's standard catalog product
- Military - QML certified for Military and Defense Applications

TAPE AND REEL INFORMATION

QUADRANT ASSIGNMENTS FOR PIN 1 ORIENTATION IN TAPE

*All dimensions are nominal

Device	Package Type	Package Drawing	Pins	SPQ	Reel Diameter (mm)	Reel Width W1 (mm)	A0 (mm)	B0 (mm)	K0 (mm)	P1 (mm)	W (mm)	Pin1 Quadrant
SN55LBC180RSAR	QFN	RSA	16	3000	330.0	12.4	4.25	4.25	1.15	8.0	12.0	Q2
SN65LBC180DR	SOIC	D	14	2500	330.0	16.4	6.5	9.0	2.1	8.0	16.0	Q1
SN65LBC180RSAR	QFN	RSA	16	3000	330.0	12.4	4.25	4.25	1.15	8.0	12.0	Q2

TAPE AND REEL BOX DIMENSIONS



*All dimensions are nominal

Device	Package Type	Package Drawing	Pins	SPQ	Length (mm)	Width (mm)	Height (mm)
SN55LBC180RSAR	QFN	RSA	16	3000	367.0	367.0	35.0
SN65LBC180DR	SOIC	D	14	2500	356.0	356.0	35.0
SN65LBC180RSAR	QFN	RSA	16	3000	367.0	367.0	35.0

TUBE

*All dimensions are nominal

Device	Package Name	Package Type	Pins	SPQ	L (mm)	W (mm)	T (μm)	B (mm)
SN65LBC180N	N	PDIP	14	25	506	13.97	11230	4.32
SN75LBC180N	N	PDIP	14	25	506	13.97	11230	4.32

D (R-PDSO-G14)

PLASTIC SMALL OUTLINE



- NOTES:
- A. All linear dimensions are in inches (millimeters).
 - B. This drawing is subject to change without notice.
 -  Body length does not include mold flash, protrusions, or gate burrs. Mold flash, protrusions, or gate burrs shall not exceed 0.006 (0,15) each side.
 -  Body width does not include interlead flash. Interlead flash shall not exceed 0.017 (0,43) each side.
 - E. Reference JEDEC MS-012 variation AB.

D (R-PDSO-G14)

PLASTIC SMALL OUTLINE



- NOTES:
- All linear dimensions are in millimeters.
 - This drawing is subject to change without notice.
 - Publication IPC-7351 is recommended for alternate designs.
 - Laser cutting apertures with trapezoidal walls and also rounding corners will offer better paste release. Customers should contact their board assembly site for stencil design recommendations. Refer to IPC-7525 for other stencil recommendations.
 - Customers should contact their board fabrication site for solder mask tolerances between and around signal pads.

N (R-PDIP-T**)

PLASTIC DUAL-IN-LINE PACKAGE

16 PINS SHOWN

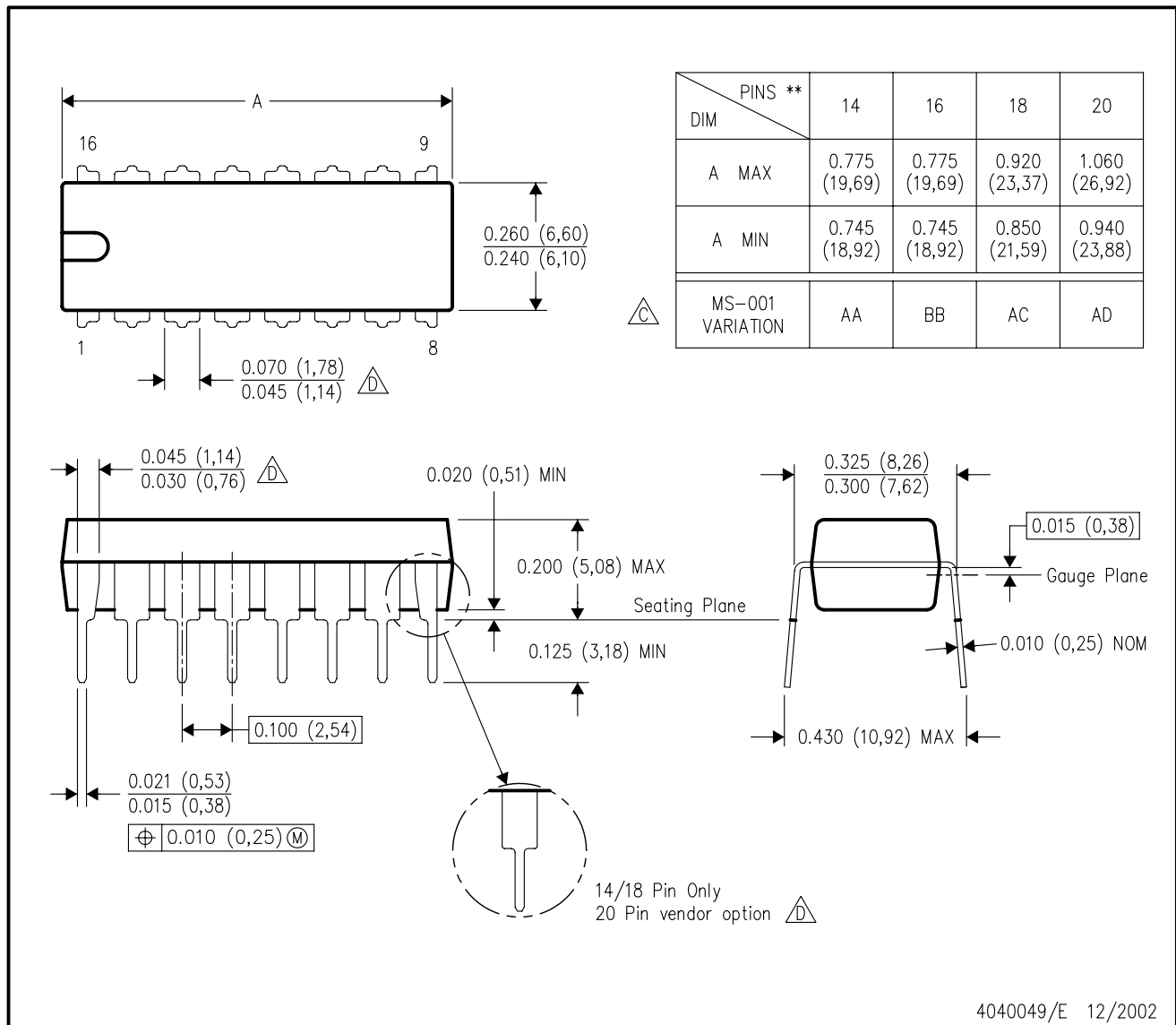

- NOTES:
- A. All linear dimensions are in inches (millimeters).
 - B. This drawing is subject to change without notice.
 - Falls within JEDEC MS-001, except 18 and 20 pin minimum body length (Dim A).
 - The 20 pin end lead shoulder width is a vendor option, either half or full width.

RSA (S-PVQFN-N16)

PLASTIC QUAD FLATPACK NO-LEAD

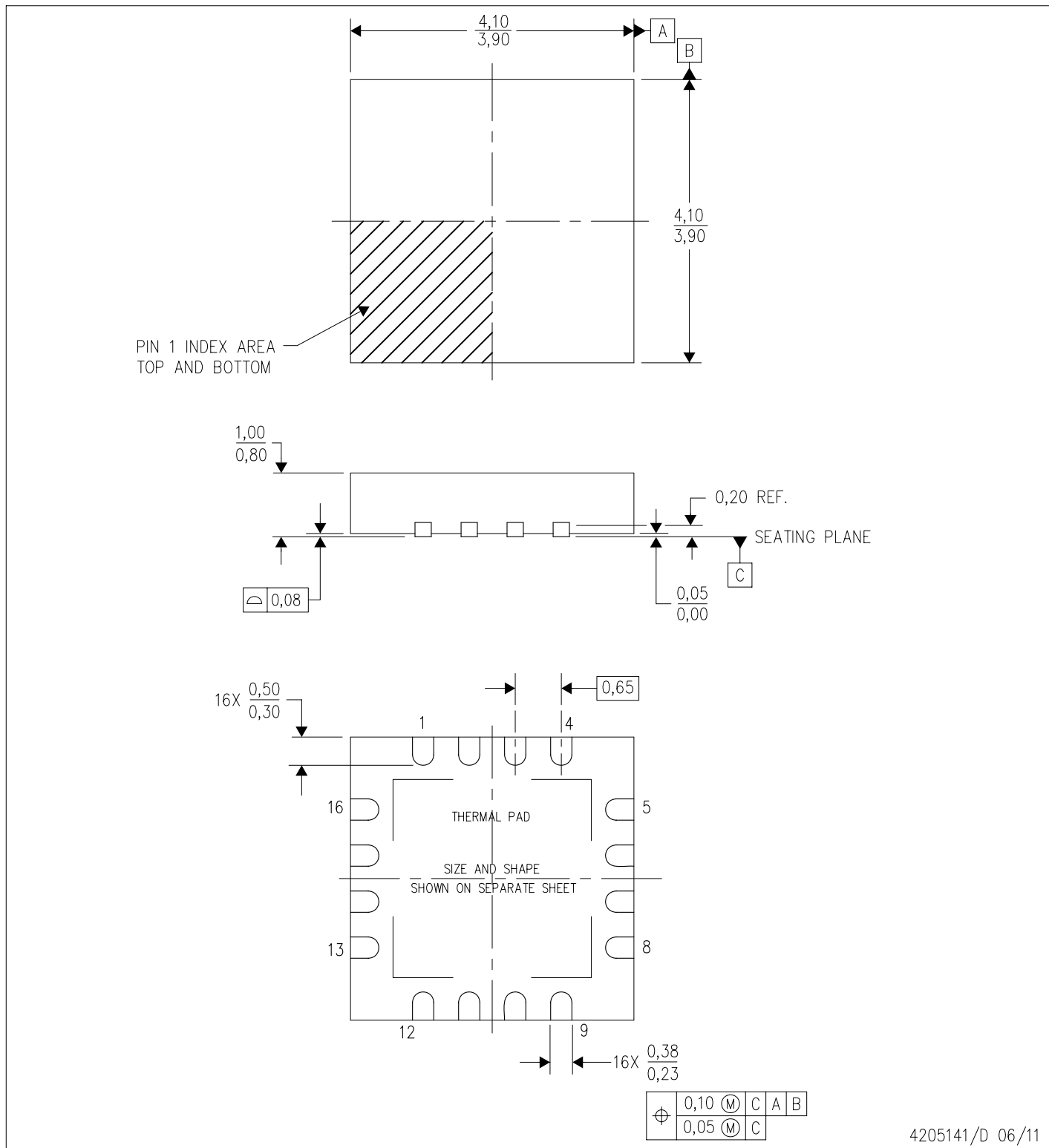

- NOTES:
- All linear dimensions are in millimeters. Dimensioning and tolerancing per ASME Y14.5M-1994.
 - This drawing is subject to change without notice.
 - Quad Flatpack, No-leads (QFN) package configuration.
 - The package thermal pad must be soldered to the board for thermal and mechanical performance.
 - See the additional figure in the Product Data Sheet for details regarding the exposed thermal pad features and dimensions.
 - Falls within JEDEC MO-220.

THERMAL INFORMATION

This package incorporates an exposed thermal pad that is designed to be attached directly to an external heatsink. The thermal pad must be soldered directly to the printed circuit board (PCB). After soldering, the PCB can be used as a heatsink. In addition, through the use of thermal vias, the thermal pad can be attached directly to the appropriate copper plane shown in the electrical schematic for the device, or alternatively, can be attached to a special heatsink structure designed into the PCB. This design optimizes the heat transfer from the integrated circuit (IC).

For information on the Quad Flatpack No-Lead (QFN) package and its advantages, refer to Application Report, QFN/SON PCB Attachment, Texas Instruments Literature No. SLUA271. This document is available at www.ti.com.

The exposed thermal pad dimensions for this package are shown in the following illustration.

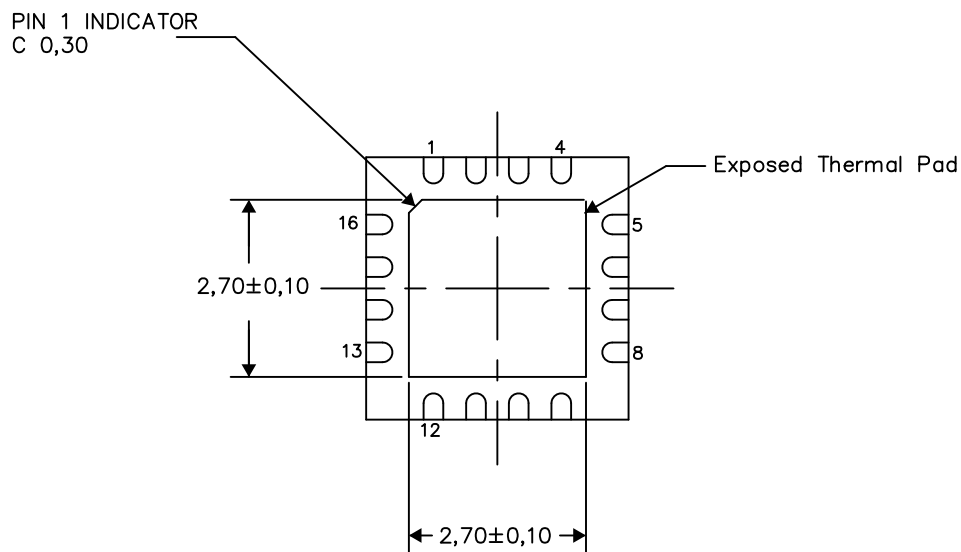

Bottom View

Exposed Thermal Pad Dimensions

4206364-2/0 09/15

NOTES:

A. All linear dimensions are in millimeters

RSA (S-PVQFN-N16)

PLASTIC QUAD FLATPACK NO-LEAD

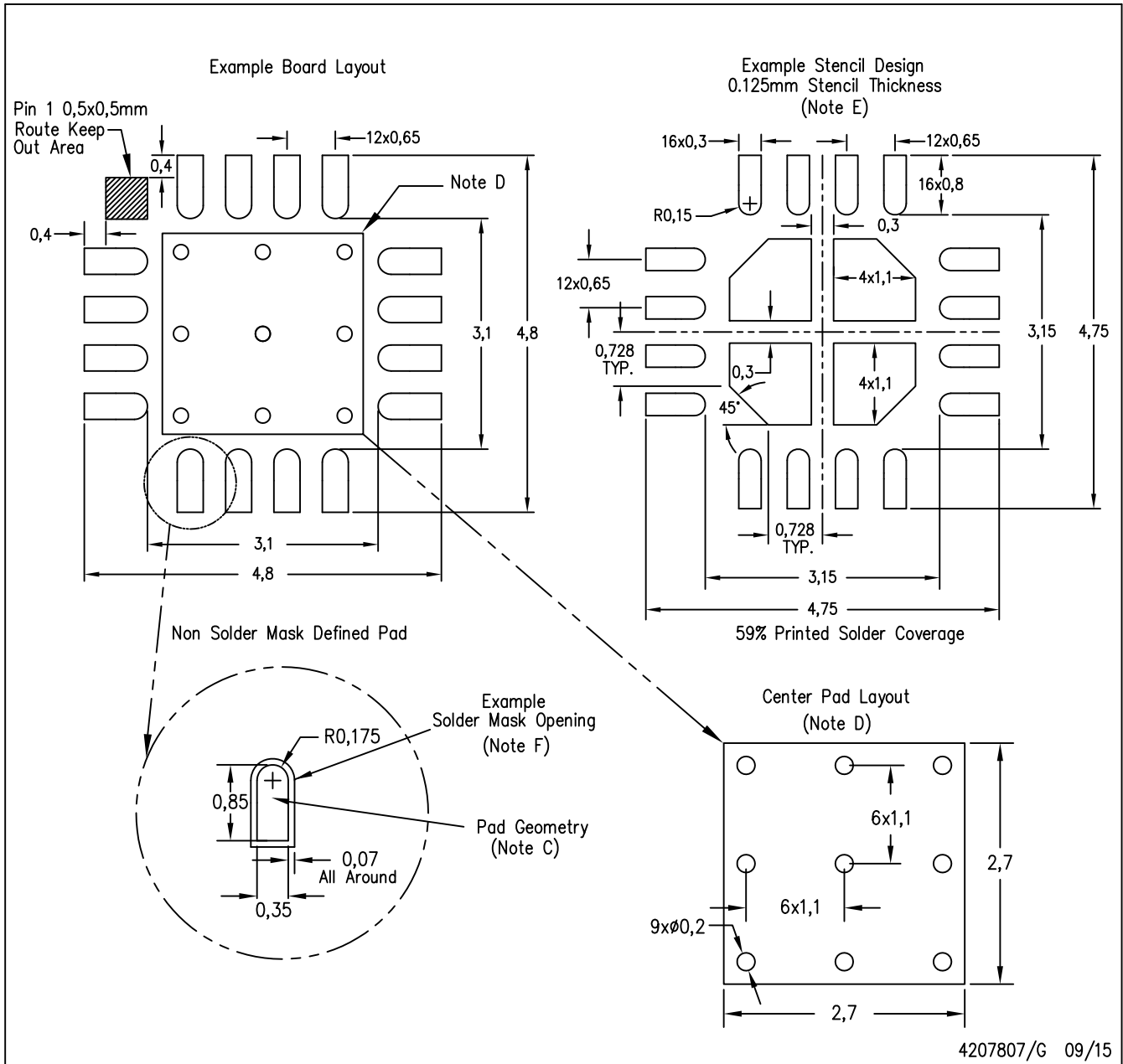

- NOTES:
- A. All linear dimensions are in millimeters.
 - B. This drawing is subject to change without notice.
 - C. Publication IPC-7351 is recommended for alternate designs.
 - D. This package is designed to be soldered to a thermal pad on the board. Refer to Application Note, QFN Packages, Texas Instruments Literature No. SLUA271, and also the Product Data Sheets for specific thermal information, via requirements, and recommended board layout. These documents are available at www.ti.com <<http://www.ti.com>>.
 - E. Laser cutting apertures with trapezoidal walls and also rounding corners will offer better paste release. Customers should contact their board assembly site for stencil design recommendations. Refer to IPC 7525 for stencil design considerations.
 - F. Customers should contact their board fabrication site for solder mask tolerances.

IMPORTANT NOTICE AND DISCLAIMER

TI PROVIDES TECHNICAL AND RELIABILITY DATA (INCLUDING DATA SHEETS), DESIGN RESOURCES (INCLUDING REFERENCE DESIGNS), APPLICATION OR OTHER DESIGN ADVICE, WEB TOOLS, SAFETY INFORMATION, AND OTHER RESOURCES "AS IS" AND WITH ALL FAULTS, AND DISCLAIMS ALL WARRANTIES, EXPRESS AND IMPLIED, INCLUDING WITHOUT LIMITATION ANY IMPLIED WARRANTIES OF MERCHANTABILITY, FITNESS FOR A PARTICULAR PURPOSE OR NON-INFRINGEMENT OF THIRD PARTY INTELLECTUAL PROPERTY RIGHTS.

These resources are intended for skilled developers designing with TI products. You are solely responsible for (1) selecting the appropriate TI products for your application, (2) designing, validating and testing your application, and (3) ensuring your application meets applicable standards, and any other safety, security, regulatory or other requirements.

These resources are subject to change without notice. TI grants you permission to use these resources only for development of an application that uses the TI products described in the resource. Other reproduction and display of these resources is prohibited. No license is granted to any other TI intellectual property right or to any third party intellectual property right. TI disclaims responsibility for, and you will fully indemnify TI and its representatives against, any claims, damages, costs, losses, and liabilities arising out of your use of these resources.

TI's products are provided subject to [TI's Terms of Sale](#) or other applicable terms available either on [ti.com](https://www.ti.com) or provided in conjunction with such TI products. TI's provision of these resources does not expand or otherwise alter TI's applicable warranties or warranty disclaimers for TI products.

TI objects to and rejects any additional or different terms you may have proposed.

Mailing Address: Texas Instruments, Post Office Box 655303, Dallas, Texas 75265
Copyright © 2024, Texas Instruments Incorporated

Looking for pricing, stock, or lifecycle information?

Click below to explore more details on WIN SOURCE:

 [View SN65LBC180RSAR on WIN SOURCE](#)

 [Texas Instruments](#) Information

Optimize Your Supply Chain with WIN SOURCE Solutions

-  Global Sourcing Solution
-  Obsolete Management
-  Cost Control Management
-  Shortage Management
-  Alternative Solution
-  Excess Inventory Management