



**THE DATASHEET OF
DS91D180TMAX/NOPB**



DS91D180/DS91C180 100 MHz M-LVDS Line Driver/Receiver Pair

 Check for Samples: [DS91C180](#), [DS91D180](#)

FEATURES

- DC to 100+ MHz / 200+ Mbps Low Power, Low EMI Operation
- Optimal for ATCA, uTCA Clock Distribution Networks
- Meets or Exceeds TIA/EIA-899 M-LVDS Standard
- Wide Input Common Mode Voltage for Increased Noise Immunity
- DS91D180 has Type 1 Receiver Input
- DS91C180 has Type 2 Receiver Input for Fail-Safe Functionality
- Industrial Temperature Range
- Space Saving SOIC-14 Package (JEDEC MS-012)

DESCRIPTION

The DS91D180 and DS91C180 are 100 MHz M-LVDS (Multipoint Low Voltage Differential Signaling) line driver/receiver pairs designed for applications that utilize multipoint networks (e.g. clock distribution in ATCA and uTCA based systems). M-LVDS is a bus interface standard (TIA/EIA-899) optimized for multidrop networks. Controlled edge rates, tight input receiver thresholds and increased drive strength are some of the key enhancements that make M-LVDS devices an ideal choice for distributing signals via multipoint networks.

The DS91D180/DS91C180 driver input accepts LVTTTL/LVCMOS signals and converts them to differential M-LVDS signal levels. The DS91D180/DS91C180 receiver accepts low voltage differential signals (LVDS, B-LVDS, M-LVDS, LVPECL and CML) and converts them to 3V LVCMOS signals. The DS91D180 device has a M-LVDS type 1 receiver input with no offset. The DS91C180 device has a type 2 receiver input which enable failsafe functionality.

Typical Application in an ATCA Clock Distribution Network

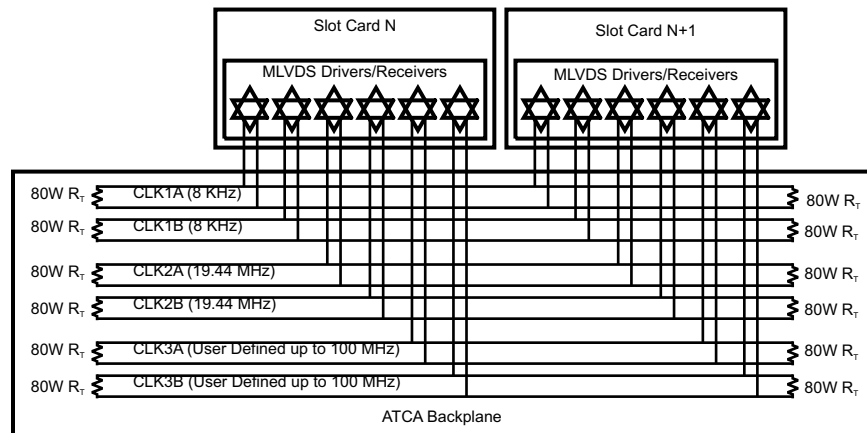

Please be aware that an important notice concerning availability, standard warranty, and use in critical applications of Texas Instruments semiconductor products and disclaimers thereto appears at the end of this data sheet.

All trademarks are the property of their respective owners.

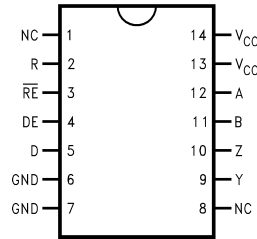

**Figure 1. Connection Diagram
Top View
See Package Number D0014A**

Logic Diagram

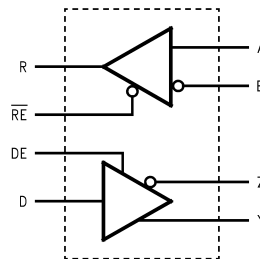

M-LVDS Receiver Types

The EIA/TIA-899 M-LVDS standard specifies two different types of receiver input stages. A type 1 receiver has a conventional threshold that is centered at the midpoint of the input amplitude, $V_{ID}/2$. A type 2 receiver has a built in offset that is 100mV greater than $V_{ID}/2$. The type 2 receiver offset acts as a failsafe circuit where open or short circuits at the input will always result in the output stage being driven to a low logic state.

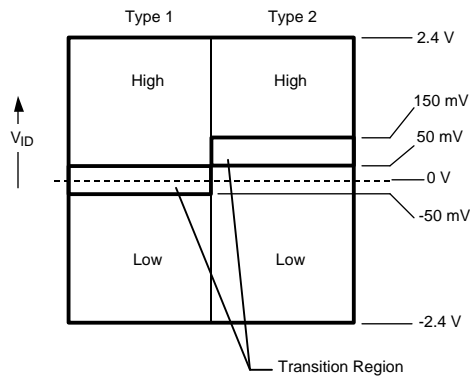

Figure 2. M-LVDS Receiver Input Thresholds



These devices have limited built-in ESD protection. The leads should be shorted together or the device placed in conductive foam during storage or handling to prevent electrostatic damage to the MOS gates.

Absolute Maximum Ratings ⁽¹⁾⁽²⁾

Supply Voltage, V_{CC}		-0.3V to +4V
Control Input Voltages		-0.3V to ($V_{CC} + 0.3V$)
Driver Input Voltage		-0.3V to ($V_{CC} + 0.3V$)
Driver Output Voltages		-1.8V to +4.1V
Receiver Input Voltages		-1.8V to +4.1V
Receiver Output Voltage		-0.3V to ($V_{CC} + 0.3V$)
Maximum Package Power Dissipation at +25°C	SOIC Package	1.1 W
	Derate SOIC Package	8.8 mW/°C above +25°C
Thermal Resistance (4-Layer, 2 oz. Cu, JEDEC)	θ_{JA}	113.7 °C/W
	θ_{JC}	36.9 °C/W
Maximum Junction Temperature		150°C
Storage Temperature Range		-65°C to +150°C
Lead Temperature (Soldering, 4 seconds)		260°C
ESD Ratings:	(HBM 1.5k Ω , 100pF)	≥ 5 kV
	(EIAJ 0 Ω , 200pF)	≥ 250 V
	(CDM 0 Ω , 0pF)	≥ 1000 V

- (1) "Absolute Maximum Ratings" are those beyond which the safety of the device cannot be ensured. They are not meant to imply that the device should be operated at these limits. The tables of "Electrical Characteristics" provide conditions for actual device operation.
- (2) If Military/Aerospace specified devices are required, please contact the TI Sales Office/Distributors for availability and specifications.

Recommended Operating Conditions

	Min	Typ	Max	Units
Supply Voltage, V_{CC}	3.0	3.3	3.6	V
Voltage at Any Bus Terminal (Separate or Common-Mode)	-1.4		+3.8	V
Differential Input Voltage V_{ID}			2.4	V
High Level Input Voltage V_{IH}	2.0		V_{CC}	V
Low Level Input Voltage V_{IL}	0		0.8	V
Operating Free Air Temperature T_A	-40	+25	+85	°C

Electrical Characteristics

 Over recommended operating supply and temperature ranges unless otherwise specified. ⁽¹⁾⁽²⁾⁽³⁾⁽⁴⁾

Symbol	Parameter	Conditions	Min	Typ	Max	Units
M-LVDS Driver						
$ V_{YZ} $	Differential output voltage magnitude	$R_L = 50\Omega$, $C_L = 5pF$ Figure 3 and Figure 5	480		650	mV
ΔV_{YZ}	Change in differential output voltage magnitude between logic states		-50	0	+50	mV
$V_{OS(SS)}$	Steady-state common-mode output voltage	$R_L = 50\Omega$, $C_L = 5pF$ Figure 3 and Figure 4	0.3	1.8	2.1	V
$ \Delta V_{OS(SS)} $	Change in steady-state common-mode output voltage between logic states		0		+50	mV
$V_{OS(PP)}$	Peak-to-peak common-mode output voltage	($V_{OS(PP)}$ @ 500KHz clock)		143		mV
$V_{Y(OC)}$	Maximum steady-state open-circuit output voltage	Figure 6	0		2.4	V
$V_{Z(OC)}$	Maximum steady-state open-circuit output voltage		0		2.4	V
$V_{P(H)}$	Voltage overshoot, low-to-high level output	$R_L = 50\Omega$, $C_L = 5pF$, $C_D = 0.5pF$ Figure 8 and Figure 9 ⁽⁵⁾			1.2 V_{SS}	V
$V_{P(L)}$	Voltage overshoot, high-to-low level output		-0.2 V_{SS}			V
I_{IH}	High-level input current (LVTTTL inputs)	$V_{IH} = 2.0V$	-15		15	μA

- (1) All currents into device pins are positive; all currents out of device pins are negative. All voltages are referenced to device ground unless otherwise specified.
- (2) All typicals are given for $V_{CC} = 3.3V$ and $T_A = 25^\circ C$.
- (3) The algebraic convention, in which the least positive (most negative) limit is designated as minimum, is used in this datasheet.
- (4) C_L includes fixture capacitance and C_D includes probe capacitance.
- (5) Not production tested. Ensured by a statistical analysis on a sample basis at the time of characterization.

Electrical Characteristics (continued)

Over recommended operating supply and temperature ranges unless otherwise specified. ⁽¹⁾⁽²⁾⁽³⁾⁽⁴⁾

Symbol	Parameter	Conditions	Min	Typ	Max	Units	
I_{IL}	Low-level input current (LVTTTL inputs)	$V_{IL} = 0.8V$	-15		15	μA	
V_{IKL}	Input Clamp Voltage (LVTTTL inputs)	$I_{IN} = -18\text{ mA}$	-1.5			V	
I_{OS}	Differential short-circuit output current	Figure 7	-43		43	mA	
M-LVDS Receiver							
V_{IT+}	Positive-going differential input voltage threshold	See Function Tables	Type 1		20	50	mV
			Type 2		94	150	mV
V_{IT-}	Negative-going differential input voltage threshold	See Function Tables	Type 1	-50	20		mV
			Type 2	50	94		mV
V_{OH}	High-level output voltage	$I_{OH} = -8\text{ mA}$	2.4	2.7		V	
V_{OL}	Low-level output voltage	$I_{OL} = 8\text{ mA}$		0.28	0.4	V	
I_{OZ}	TRI-STATE output current	$V_O = 0V$ or $3.6V$	-10		10	μA	
I_{OSR}	Short circuit Receiver output current (LVTTTL Output)	$V_O = 0V$	-90	-48		mA	
M-LVDS Bus (Input and Output) Pins							
I_A, I_Y	Receiver input or driver high-impedance output current	$V_{A,Y} = 3.8V, V_{B,Z} = 1.2V, DE = GND$			32	μA	
		$V_{A,Y} = 0V$ or $2.4V, V_{B,Z} = 1.2V, DE = GND$	-20		+20	μA	
		$V_{A,Y} = -1.4V, V_{B,Z} = 1.2V, DE = GND$	-32			μA	
I_B, I_Z	Receiver input or driver high-impedance output current	$V_{B,Z} = 3.8V, V_{A,Y} = 1.2V, DE = GND$			32	μA	
		$V_{B,Z} = 0V$ or $2.4V, V_{A,Y} = 1.2V, DE = GND$	-20		+20	μA	
		$V_{B,Z} = -1.4V, V_{A,Y} = 1.2V, DE = GND$	-32			μA	
I_{AB}, I_{YZ}	Receiver input or driver high-impedance output differential current ($I_A - I_B$ or $I_Y - I_Z$)	$V_{A,Y} = V_{B,Z}, -1.4V \leq V \leq 3.8V, DE = GND$	-4		+4	μA	
$I_{A(OFF)}, I_{Y(OFF)}$	Receiver input or driver high-impedance output power-off current	$V_{A,Y} = 3.8V, V_{B,Z} = 1.2V, DE = 0V, 0V \leq V_{CC} \leq 1.5V$			32	μA	
		$V_{A,Y} = 0V$ or $2.4V, V_{B,Z} = 1.2V, DE = 0V, 0V \leq V_{CC} \leq 1.5V$	-20		+20	μA	
		$V_{A,Y} = -1.4V, V_{B,Z} = 1.2V, DE = 0V, 0V \leq V_{CC} \leq 1.5V$	-32			μA	
$I_{B(OFF)}, I_{Z(OFF)}$	Receiver input or driver high-impedance output power-off current	$V_{B,Z} = 3.8V, V_{A,Y} = 1.2V, DE = 0V, 0V \leq V_{CC} \leq 1.5V$			32	μA	
		$V_{B,Z} = 0V$ or $2.4V, V_{A,Y} = 1.2V, DE = 0V, 0V \leq V_{CC} \leq 1.5V$	-20		+20	μA	
		$V_{B,Z} = -1.4V, V_{A,Y} = 1.2V, DE = 0V, 0V \leq V_{CC} \leq 1.5V$	-32			μA	
$I_{AB(OFF)}, I_{YZ(OFF)}$	Receiver input or driver high-impedance output power-off differential current ($I_{A(OFF)} - I_{B(OFF)}$ or $I_{Y(OFF)} - I_{Z(OFF)}$)	$V_{A,Y} = V_{B,Z}, -1.4V \leq V \leq 3.8V, DE = 0V, 0V \leq V_{CC} \leq 1.5V$	-4		+4	μA	
C_A, C_B	Receiver input capacitance	$V_{CC} = OPEN$		5.1		pF	
C_Y, C_Z	Driver output capacitance			8.5		pF	
C_{AB}	Receiver input differential capacitance			2.5		pF	
C_{YZ}	Driver output differential capacitance			5.5		pF	

Electrical Characteristics (continued)

 Over recommended operating supply and temperature ranges unless otherwise specified. ⁽¹⁾⁽²⁾⁽³⁾⁽⁴⁾

Symbol	Parameter	Conditions	Min	Typ	Max	Units
$C_{A/B}$, $C_{Y/Z}$	Receiver input or driver output capacitance balance (C_A/C_B or C_Y/C_Z)			1.0		
SUPPLY CURRENT (V_{CC})						
I_{CCD}	Driver Supply Current	$R_L = 50\Omega$, $DE = V_{CC}$, $\overline{RE} = V_{CC}$		17	29.5	mA
I_{CCZ}	TRI-STATE Supply Current	$DE = GND$, $\overline{RE} = V_{CC}$		7	9.0	mA
I_{CCR}	Receiver Supply Current	$DE = GND$, $\overline{RE} = GND$		14	18.5	mA
I_{CCB}	Supply Current, Driver and Receiver Enabled	$DE = V_{CC}$, $\overline{RE} = GND$		20	29.5	mA

Switching Characteristics

 Over recommended operating supply and temperature ranges unless otherwise specified. ^{(1) (2)}

Symbol	Parameter	Conditions	Min	Typ	Max	Units
DRIVER AC SPECIFICATION						
t_{PLH}	Differential Propagation Delay Low to High	$R_L = 50\Omega$, $C_L = 5\text{ pF}$,	1.0	3.4	5.5	ns
t_{PHL}	Differential Propagation Delay High to Low	$C_D = 0.5\text{ pF}$	1.0	3.1	5.5	ns
t_{SKD1} ($t_{sk(p)}$)	Pulse Skew $ t_{PLHD} - t_{PHLD} $ ^{(3) (4)}	Figure 8 and Figure 9		300	420	ps
t_{SKD3}	Part-to-Part Skew ^{(5) (4)}				1.9	ns
t_{TLH} (t_r)	Rise Time ⁽⁴⁾		1.0	1.8	3.0	ns
t_{THL} (t_f)	Fall Time ⁽⁴⁾		1.0	1.8	3.0	ns
t_{PZH}	Enable Time (Z to Active High)	$R_L = 50\Omega$, $C_L = 5\text{ pF}$,			8	ns
t_{PZL}	Enable Time (Z to Active Low)	$C_D = 0.5\text{ pF}$			8	ns
t_{PLZ}	Disable Time (Active Low to Z)	Figure 10 and Figure 11			8	ns
t_{PHZ}	Disable Time (Active High to Z)				8	ns
t_{JIT}	Random Jitter, RJ ⁽⁴⁾	100MHz clock pattern ⁽⁶⁾		2.5	5.5	psrms
f_{MAX}	Maximum Data Rate		200			Mbps
RECEIVER AC SPECIFICATION						
t_{PLH}	Propagation Delay Low to High	$C_L = 15\text{ pF}$	2.0	4.7	7.5	ns
t_{PHL}	Propagation Delay High to Low	Figure 12 Figure 13 and Figure 14	2.0	5.3	7.5	ns
t_{SKD1} ($t_{sk(p)}$)	Pulse Skew $ t_{PLHD} - t_{PHLD} $ ⁽³⁾⁽⁴⁾			0.6	1.9	ns
t_{SKD3}	Part-to-Part Skew ⁽⁵⁾⁽⁴⁾				1.5	ns
t_{TLH} (t_r)	Rise Time ⁽⁴⁾		0.5	1.2	3.0	ns
t_{THL} (t_f)	Fall Time ⁽⁴⁾		0.5	1.2	3.0	ns
t_{PZH}	Enable Time (Z to Active High)	$R_L = 500\Omega$, $C_L = 15\text{ pF}$			10	ns
t_{PZL}	Enable Time (Z to Active Low)	Figure 15 and Figure 16			10	ns
t_{PLZ}	Disable Time (Active Low to Z)				10	ns
t_{PHZ}	Disable Time (Active High to Z)				10	ns
f_{MAX}	Maximum Data Rate		200			Mbps

 (1) All typicals are given for $V = 3.3V$ and $T_A = 25^\circ C$.

 (2) C_L includes fixture capacitance and C_D includes probe capacitance.

 (3) t_{SKD1} , $|t_{PLHD} - t_{PHLD}|$, is the magnitude difference in differential propagation delay time between the positive going edge and the negative going edge of the same channel.

(4) Not production tested. Ensured by a statistical analysis on a sample basis at the time of characterization.

 (5) t_{SKD3} , Part-to-Part Skew, is defined as the difference between the minimum and maximum specified differential propagation delays. This specification applies to devices at the same V_{CC} and within $5^\circ C$ of each other within the operating temperature range.

(6) Stimulus and fixture jitter has been subtracted.

Test Circuits and Waveforms

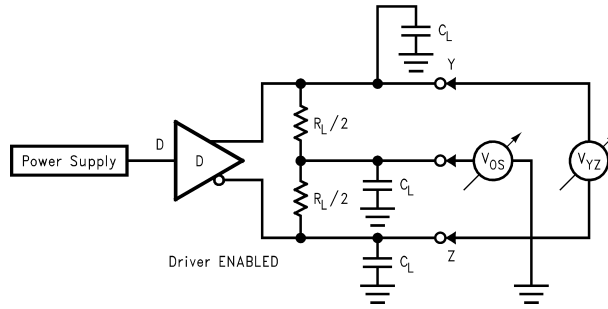

Figure 3. Differential Driver Test Circuit

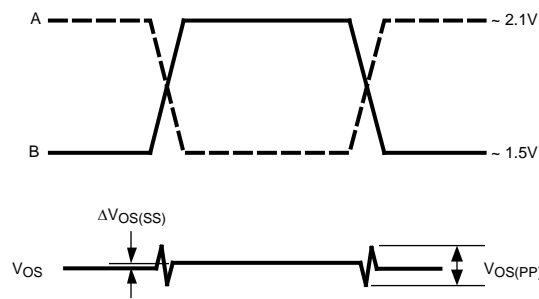

Figure 4. Differential Driver Waveforms

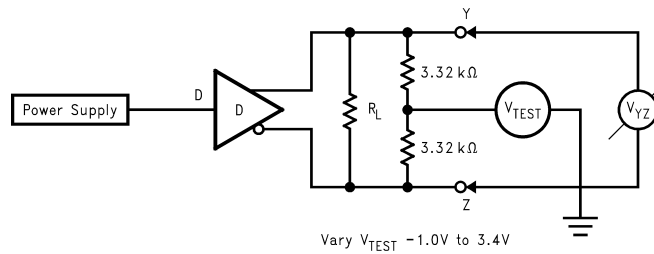

Figure 5. Differential Driver Full Load Test Circuit

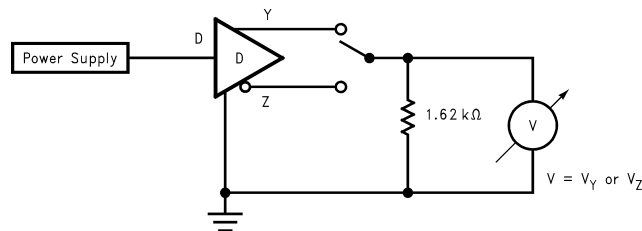

Figure 6. Differential Driver DC Open Test Circuit

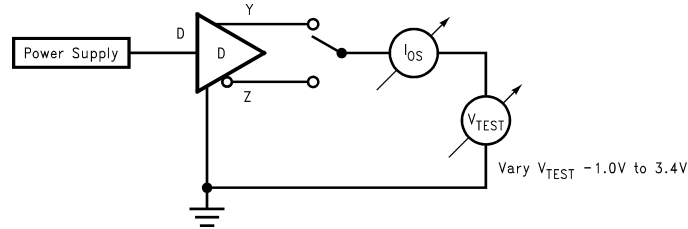

Figure 7. Differential Driver Short-Circuit Test Circuit

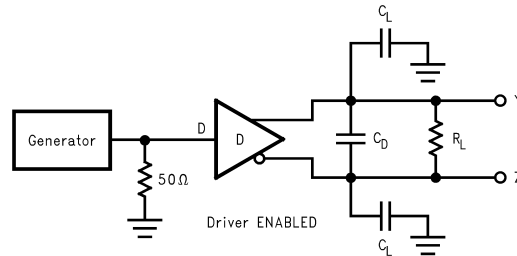

Figure 8. Driver Propagation Delay and Transition Time Test Circuit

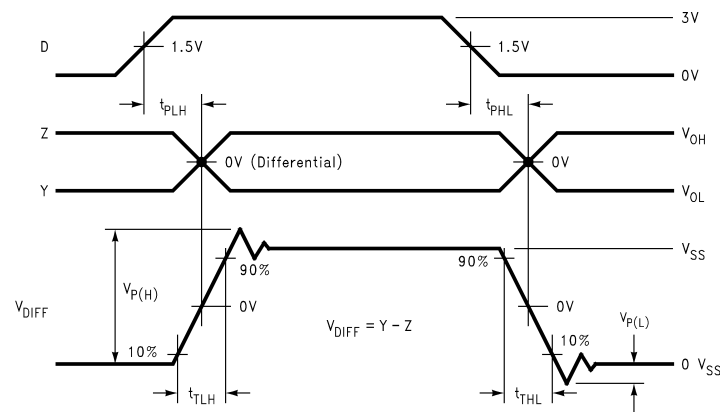

Figure 9. Driver Propagation Delays and Transition Time Waveforms

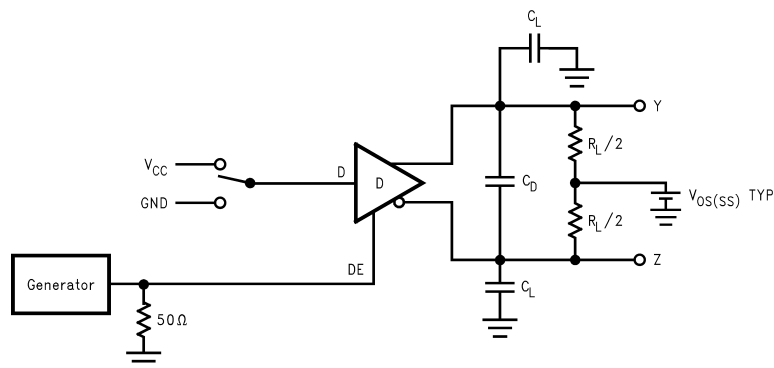

Figure 10. Driver TRI-STATE Delay Test Circuit

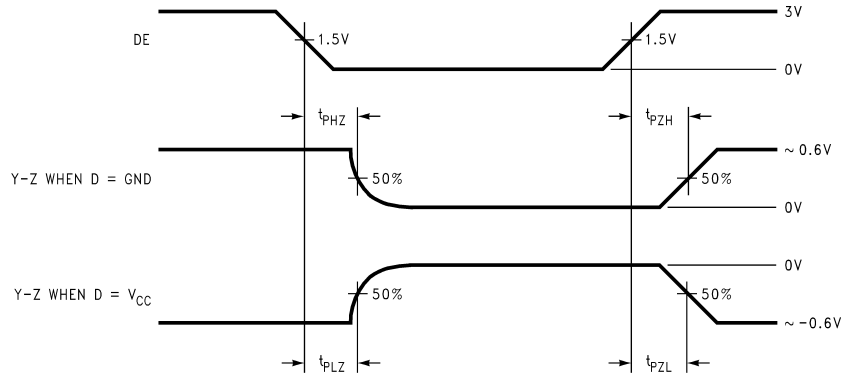

Figure 11. Driver TRI-STATE Delay Waveforms

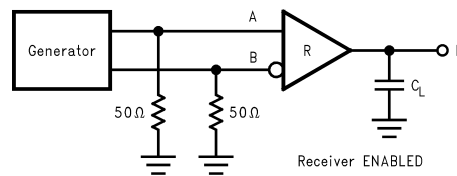

Figure 12. Receiver Propagation Delay and Transition Time Test Circuit

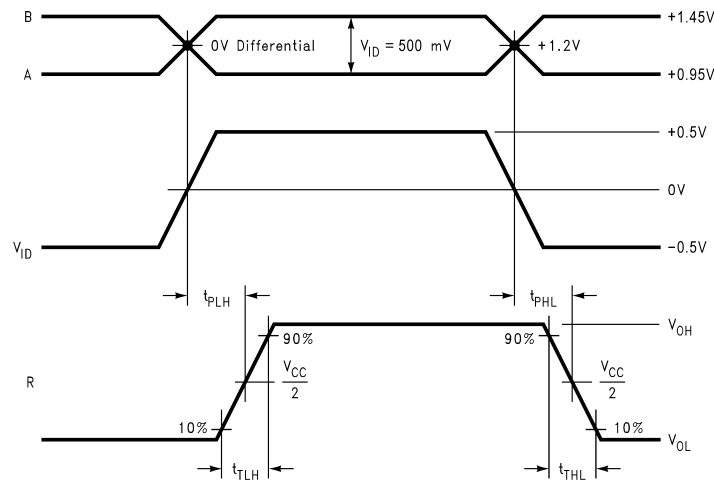

Figure 13. Type 1 Receiver Propagation Delay and Transition Time Waveforms

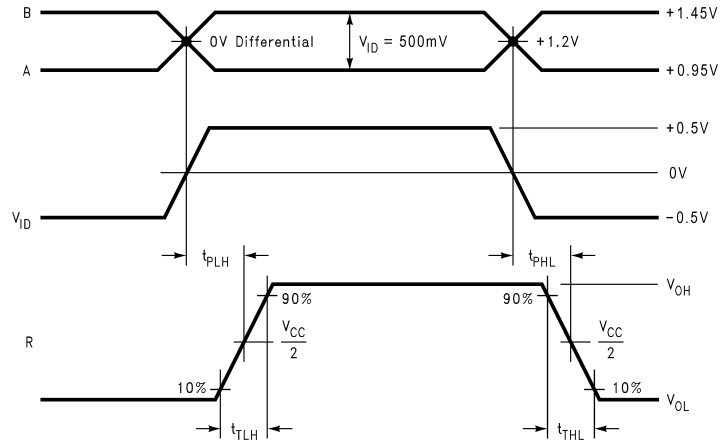

Figure 14. Type 2 Receiver Propagation Delay and Transition Time Waveforms

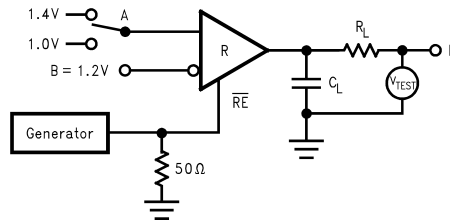

Figure 15. Receiver TRI-STATE Delay Test Circuit

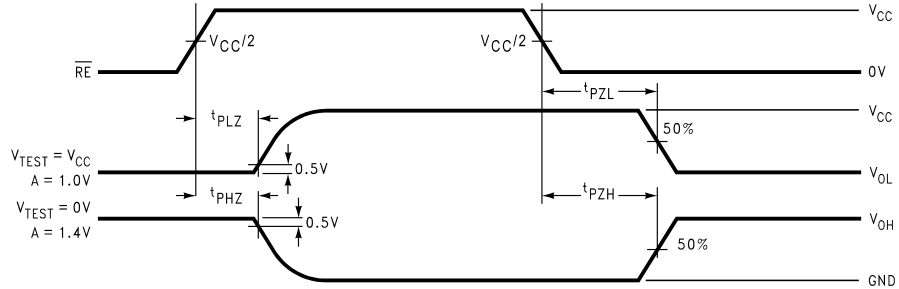

Figure 16. Receiver TRI-STATE Delay Waveforms

FUNCTION TABLES

Table 1. DS91D180/DS91C180 Transmitting⁽¹⁾

Inputs		Outputs	
DE	D	Z	Y
2.0V	2.0V	L	H
2.0V	0.8V	H	L
0.8V	X	Z	Z

- (1) X — Don't care condition
Z — High impedance state

Table 2. DS91D180 Receiving⁽¹⁾

Inputs		Output
\overline{RE}	A - B	R
0.8V	$\geq +0.05V$	H
0.8V	$\leq -0.05V$	L
0.8V	0V	X
2.0V	X	Z

- (1) X — Don't care condition
Z — High impedance state

Table 3. DS91C180 Receiving⁽¹⁾

Inputs		Output
\overline{RE}	A - B	R
0.8V	$\geq +0.15V$	H
0.8V	$\leq +0.05V$	L
0.8V	0V	L
2.0V	X	Z

- (1) X — Don't care condition
Z — High impedance state

Table 4. DS91D180 Receiver Input Threshold Test Voltages⁽¹⁾

Applied Voltages		Resulting Differential Input Voltage	Resulting Common-Mode Input Voltage	Receiver Output
V_{IA}	V_{IB}	V_{ID}	V_{IC}	R
2.400V	0.000V	2.400V	1.200V	H
0.000V	2.400V	-2.400V	1.200V	L
3.800V	3.750V	0.050V	3.775V	H
3.750V	3.800V	-0.050V	3.775V	L
-1.400V	-1.350V	-0.050V	-1.375V	H
-1.350V	-1.400V	0.050V	-1.375V	L

- (1) H — High Level
L — Low Level
Output state assumes that the receiver is enabled ($\overline{RE} = L$)

Table 5. DS91C180 Receiver Input Threshold Test Voltages⁽¹⁾

Applied Voltages		Resulting Differential Input Voltage	Resulting Common-Mode Input Voltage	Receiver Output
V_{IA}	V_{IB}	V_{ID}	V_{IC}	R
2.400V	0.000V	2.400V	1.200V	H
0.000V	2.400V	-2.400V	1.200V	L
3.800V	3.650V	0.150V	3.725V	H
3.800V	3.750V	0.050V	3.775V	L
-1.250V	-1.400V	0.150V	-1.325V	H
-1.350V	-1.400V	0.050V	-1.375V	L

- (1) H — High Level
 L — Low Level
 Output state assumes that the receiver is enabled ($\overline{RE} = L$)

PIN DESCRIPTIONS

Pin No.	Name	Description
1, 8	NC	No connect.
2	R	Receiver output pin
3	\overline{RE}	Receiver enable pin: When \overline{RE} is high, the receiver is disabled. When \overline{RE} is low or open, the receiver is enabled.
4	DE	Driver enable pin: When DE is low, the driver is disabled. When DE is high, the driver is enabled.
5	D	Driver input pin
6, 7	GND	Ground pin
9	Y	Non-inverting driver output pin
10	Z	Inverting driver output pin
11	B	Inverting receiver input pin
12	A	Non-inverting receiver input pin
13, 14	V_{CC}	Power supply pin, +3.3V \pm 0.3V

REVISION HISTORY

Changes from Revision L (April 2013) to Revision M	Page
• Changed layout of National Data Sheet to TI format	11

PACKAGING INFORMATION

Orderable Device	Status (1)	Package Type	Package Drawing	Pins	Package Qty	Eco Plan (2)	Lead/Ball Finish (6)	MSL Peak Temp (3)	Op Temp (°C)	Device Marking (4/5)	Samples
DS91C180TMA/NOPB	ACTIVE	SOIC	D	14	55	Green (RoHS & no Sb/Br)	CU SN	Level-1-260C-UNLIM	-40 to 85	DS91C180 TMA	Samples
DS91C180TMAX/NOPB	ACTIVE	SOIC	D	14	2500	Green (RoHS & no Sb/Br)	CU SN	Level-1-260C-UNLIM	-40 to 85	DS91C180 TMA	Samples
DS91D180TMA/NOPB	ACTIVE	SOIC	D	14	55	Green (RoHS & no Sb/Br)	CU SN	Level-1-260C-UNLIM	-40 to 85	DS91D180 TMA	Samples
DS91D180TMAX/NOPB	ACTIVE	SOIC	D	14	2500	Green (RoHS & no Sb/Br)	CU SN	Level-1-260C-UNLIM	-40 to 85	DS91D180 TMA	Samples

(1) The marketing status values are defined as follows:

ACTIVE: Product device recommended for new designs.

LIFEBUY: TI has announced that the device will be discontinued, and a lifetime-buy period is in effect.

NRND: Not recommended for new designs. Device is in production to support existing customers, but TI does not recommend using this part in a new design.

PREVIEW: Device has been announced but is not in production. Samples may or may not be available.

OBsolete: TI has discontinued the production of the device.

(2) **RoHS:** TI defines "RoHS" to mean semiconductor products that are compliant with the current EU RoHS requirements for all 10 RoHS substances, including the requirement that RoHS substance do not exceed 0.1% by weight in homogeneous materials. Where designed to be soldered at high temperatures, "RoHS" products are suitable for use in specified lead-free processes. TI may reference these types of products as "Pb-Free".

RoHS Exempt: TI defines "RoHS Exempt" to mean products that contain lead but are compliant with EU RoHS pursuant to a specific EU RoHS exemption.

Green: TI defines "Green" to mean the content of Chlorine (Cl) and Bromine (Br) based flame retardants meet JS709B low halogen requirements of <=1000ppm threshold. Antimony trioxide based flame retardants must also meet the <=1000ppm threshold requirement.

(3) MSL, Peak Temp. - The Moisture Sensitivity Level rating according to the JEDEC industry standard classifications, and peak solder temperature.

(4) There may be additional marking, which relates to the logo, the lot trace code information, or the environmental category on the device.

(5) Multiple Device Markings will be inside parentheses. Only one Device Marking contained in parentheses and separated by a "-" will appear on a device. If a line is indented then it is a continuation of the previous line and the two combined represent the entire Device Marking for that device.

(6) Lead/Ball Finish - Orderable Devices may have multiple material finish options. Finish options are separated by a vertical ruled line. Lead/Ball Finish values may wrap to two lines if the finish value exceeds the maximum column width.

Important Information and Disclaimer: The information provided on this page represents TI's knowledge and belief as of the date that it is provided. TI bases its knowledge and belief on information provided by third parties, and makes no representation or warranty as to the accuracy of such information. Efforts are underway to better integrate information from third parties. TI has taken and

continues to take reasonable steps to provide representative and accurate information but may not have conducted destructive testing or chemical analysis on incoming materials and chemicals. TI and TI suppliers consider certain information to be proprietary, and thus CAS numbers and other limited information may not be available for release.

In no event shall TI's liability arising out of such information exceed the total purchase price of the TI part(s) at issue in this document sold by TI to Customer on an annual basis.

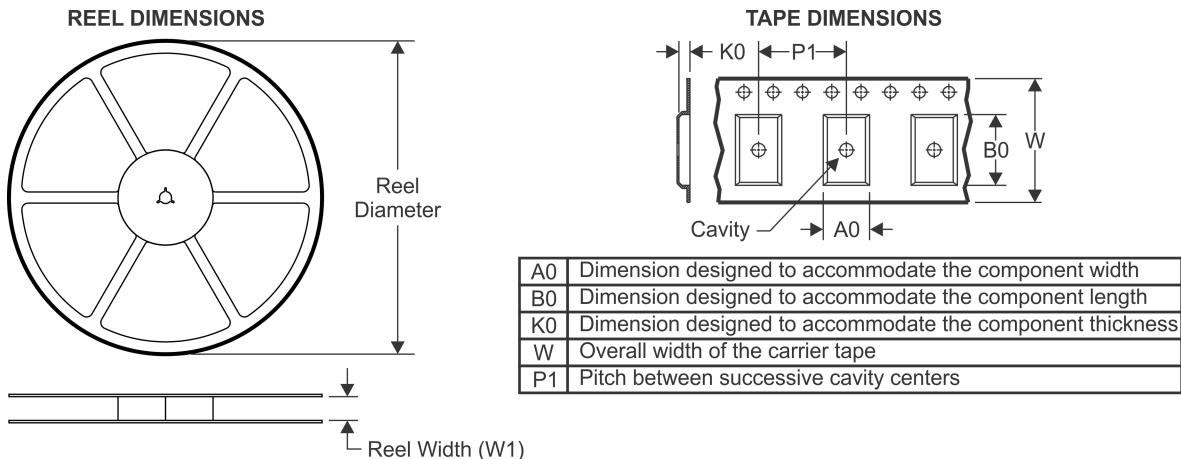
TAPE AND REEL INFORMATION

QUADRANT ASSIGNMENTS FOR PIN 1 ORIENTATION IN TAPE

*All dimensions are nominal

Device	Package Type	Package Drawing	Pins	SPQ	Reel Diameter (mm)	Reel Width W1 (mm)	A0 (mm)	B0 (mm)	K0 (mm)	P1 (mm)	W (mm)	Pin1 Quadrant
DS91C180TMAX/NOPB	SOIC	D	14	2500	330.0	16.4	6.5	9.35	2.3	8.0	16.0	Q1
DS91D180TMAX/NOPB	SOIC	D	14	2500	330.0	16.4	6.5	9.35	2.3	8.0	16.0	Q1

TAPE AND REEL BOX DIMENSIONS



*All dimensions are nominal

Device	Package Type	Package Drawing	Pins	SPQ	Length (mm)	Width (mm)	Height (mm)
DS91C180TMAX/NOPB	SOIC	D	14	2500	367.0	367.0	35.0
DS91D180TMAX/NOPB	SOIC	D	14	2500	367.0	367.0	35.0

D (R-PDSO-G14)

PLASTIC SMALL OUTLINE



- NOTES:
- A. All linear dimensions are in inches (millimeters).
 - B. This drawing is subject to change without notice.
 -  Body length does not include mold flash, protrusions, or gate burrs. Mold flash, protrusions, or gate burrs shall not exceed 0.006 (0,15) each side.
 -  Body width does not include interlead flash. Interlead flash shall not exceed 0.017 (0,43) each side.
 - E. Reference JEDEC MS-012 variation AB.

D (R-PDSO-G14)

PLASTIC SMALL OUTLINE



- NOTES:
- A. All linear dimensions are in millimeters.
 - B. This drawing is subject to change without notice.
 - C. Publication IPC-7351 is recommended for alternate designs.
 - D. Laser cutting apertures with trapezoidal walls and also rounding corners will offer better paste release. Customers should contact their board assembly site for stencil design recommendations. Refer to IPC-7525 for other stencil recommendations.
 - E. Customers should contact their board fabrication site for solder mask tolerances between and around signal pads.

IMPORTANT NOTICE AND DISCLAIMER

TI PROVIDES TECHNICAL AND RELIABILITY DATA (INCLUDING DATASHEETS), DESIGN RESOURCES (INCLUDING REFERENCE DESIGNS), APPLICATION OR OTHER DESIGN ADVICE, WEB TOOLS, SAFETY INFORMATION, AND OTHER RESOURCES "AS IS" AND WITH ALL FAULTS, AND DISCLAIMS ALL WARRANTIES, EXPRESS AND IMPLIED, INCLUDING WITHOUT LIMITATION ANY IMPLIED WARRANTIES OF MERCHANTABILITY, FITNESS FOR A PARTICULAR PURPOSE OR NON-INFRINGEMENT OF THIRD PARTY INTELLECTUAL PROPERTY RIGHTS.

These resources are intended for skilled developers designing with TI products. You are solely responsible for (1) selecting the appropriate TI products for your application, (2) designing, validating and testing your application, and (3) ensuring your application meets applicable standards, and any other safety, security, or other requirements. These resources are subject to change without notice. TI grants you permission to use these resources only for development of an application that uses the TI products described in the resource. Other reproduction and display of these resources is prohibited. No license is granted to any other TI intellectual property right or to any third party intellectual property right. TI disclaims responsibility for, and you will fully indemnify TI and its representatives against, any claims, damages, costs, losses, and liabilities arising out of your use of these resources.

TI's products are provided subject to TI's Terms of Sale (www.ti.com/legal/termsofsale.html) or other applicable terms available either on ti.com or provided in conjunction with such TI products. TI's provision of these resources does not expand or otherwise alter TI's applicable warranties or warranty disclaimers for TI products.

Mailing Address: Texas Instruments, Post Office Box 655303, Dallas, Texas 75265
Copyright © 2019, Texas Instruments Incorporated

Looking for pricing, stock, or lifecycle information?

Click below to explore more details on WIN SOURCE:

 [View DS91D180TMAX/NOPB on WIN SOURCE](#)

 [Texas Instruments](#) Information

Optimize Your Supply Chain with WIN SOURCE Solutions

-  Global Sourcing Solution
-  Obsolete Management
-  Cost Control Management
-  Shortage Management
-  Alternative Solution
-  Excess Inventory Management