



**THE DATASHEET OF  
TPS40211DGQRG4**



## TPS4021x 4.5-V to 52-V Input Current Mode Boost Controller

### 1 Features

- For Boost, Flyback, SEPIC, LED Drive Apps
- Wide Input Operating Voltage: 4.5 V to 52 V
- Adjustable Oscillator Frequency
- Fixed Frequency Current Mode Control
- Internal Slope Compensation
- Integrated Low-Side Driver
- Programmable Closed-Loop Soft-Start
- Overcurrent Protection
- External Synchronization Capable
- Reference 700 mV (TPS40210), 260 mV (TPS40211)
- Low Current Disable Function
- Create a Custom Design Using the TPS4021x with the [WEBENCH Power Designer](#)

### 2 Applications

- LED Lighting
- Industrial Control Systems
- Battery Powered Systems

### 3 Description

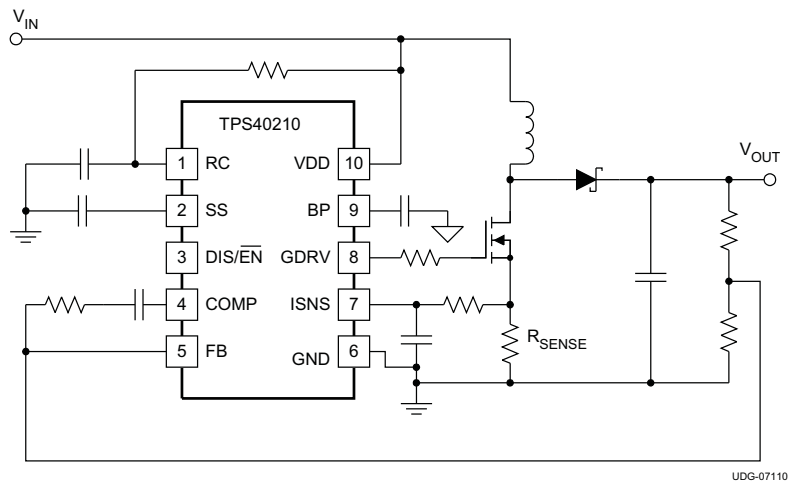
The TPS40210 and TPS40211 are wide-input voltage (4.5 V to 52 V), nonsynchronous boost controllers. They are suitable for topologies which require a grounded source N-channel FET including boost, flyback, SEPIC and various LED Driver applications. The device features include programmable soft-start, overcurrent protection with automatic retry and programmable oscillator frequency. Current mode control provides improved transient response and simplified loop compensation. The main difference between the two parts is the reference voltage to which the error amplifier regulates the FB pin.

#### Device Information<sup>(1)</sup>

PART NUMBER	PACKAGE	BODY SIZE (NOM)
TPS40210	HVSSOP (10)	3.05 mm x 4.98 mm
TPS40211	VSON (10)	3.10 mm x 3.10 mm

(1) For all available packages, see the orderable addendum at the end of the datasheet.

#### Simplified Schematic



## Table of Contents

<p><b>1 Features</b> ..... 1</p> <p><b>2 Applications</b> ..... 1</p> <p><b>3 Description</b> ..... 1</p> <p><b>4 Revision History</b>..... 2</p> <p><b>5 Pin Configuration and Functions</b> ..... 3</p> <p><b>6 Specifications</b>..... 3</p> <p>    6.1 Absolute Maximum Ratings ..... 3</p> <p>    6.2 ESD Ratings ..... 4</p> <p>    6.3 Recommended Operating Conditions..... 4</p> <p>    6.4 Thermal Information ..... 4</p> <p>    6.5 Electrical Characteristics..... 4</p> <p>    6.6 Typical Characteristics ..... 6</p> <p><b>7 Detailed Description</b> ..... 10</p> <p>    7.1 Overview ..... 10</p> <p>    7.2 Functional Block Diagram ..... 10</p> <p>    7.3 Feature Description..... 11</p>	<p>    7.4 Device Functional Modes..... 23</p> <p><b>8 Application and Implementation</b> ..... 24</p> <p>    8.1 Application Information..... 24</p> <p>    8.2 Typical Applications ..... 24</p> <p><b>9 Power Supply Recommendations</b> ..... 35</p> <p><b>10 Layout</b>..... 35</p> <p>    10.1 Layout Guidelines ..... 35</p> <p>    10.2 Layout Example ..... 35</p> <p><b>11 Device and Documentation Support</b> ..... 38</p> <p>    11.1 Device Support..... 38</p> <p>    11.2 Documentation Support ..... 38</p> <p>    11.3 Related Links ..... 39</p> <p>    11.4 Trademarks ..... 39</p> <p>    11.5 Electrostatic Discharge Caution..... 39</p> <p>    11.6 Glossary ..... 39</p> <p><b>12 Mechanical, Packaging, and Orderable Information</b> ..... 39</p>
---	--

## 4 Revision History

NOTE: Page numbers for previous revisions may differ from page numbers in the current version.

### Changes from Revision E (October 2011) to Revision F

**Page**

<ul style="list-style-type: none"> <li>• Added Updated Land Pattern ..... 1</li> <li>• Added <i>ESD Ratings</i> table, <i>Feature Description</i> section, <i>Device Functional Modes</i>, <i>Application and Implementation</i> section, <i>Power Supply Recommendations</i> section, <i>Layout</i> section, <i>Device and Documentation Support</i> section, and <i>Mechanical, Packaging, and Orderable Information</i> section ..... 1</li> </ul>	<p>1</p> <p>1</p>
---	-------------------

### Changes from Revision D (April 2010) to Revision E

**Page**

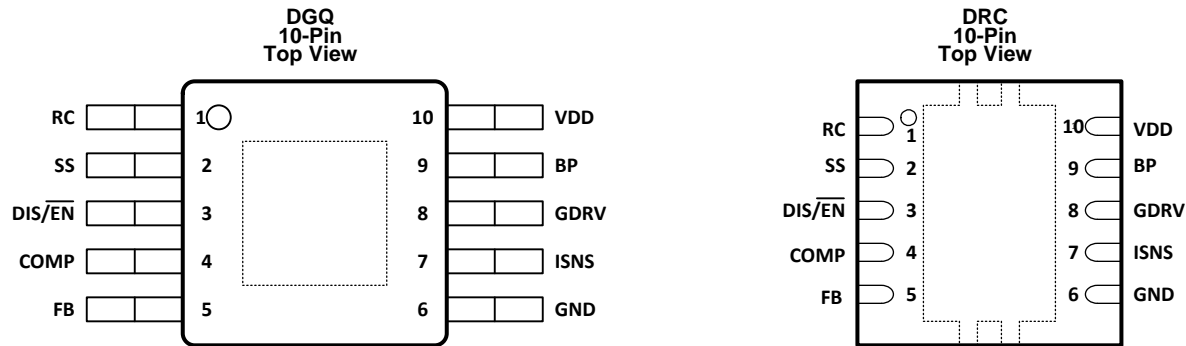
<ul style="list-style-type: none"> <li>• Changed the Revision date from D, April 2010 to E, October 2011 ..... 1</li> <li>• Added Q1 and Q3 to Figure 36 by illustrator..... 33</li> </ul>	<p>1</p> <p>33</p>
--	--------------------

### Changes from Revision C (October 2008) to Revision D

**Page**

<ul style="list-style-type: none"> <li>• Changed <math>C_{ISNS}</math> to <math>C_{IFLT}</math> ..... 19</li> <li>• Changed <math>C_{ISNS}</math> to <math>C_{IFLT}</math> ..... 19</li> <li>• Changed equations 22 and 23 ..... 20</li> <li>• Changed corrected equation 25 ..... 21</li> <li>• Added "R1 is the high side feedback resistor in <math>\Omega</math>" and " <math>f_L</math> is the desired loop crossover frequency, in Hz" ..... 21</li> <li>• Changed paragraph with new input..... 21</li> <li>• Changed capacitor value from <math>\mu F</math> to F ..... 21</li> <li>• Changed 0.2 with 0.1 in MIN col in Design Example Specifications table ..... 25</li> <li>• Deleted text from Peak efficiency row ..... 25</li> <li>• Changed 10 V with 8 V in <math>T_{OP}</math> conditions column ..... 25</li> <li>• Changed 42.8% to 42.9% in eq 32..... 26</li> <li>• Added (<math>V_{FD}</math>) and changed approximate duty cycle from 42.8% to 42.9% ..... 26</li> <li>• Changed equations 32, 34, 35, 36, 37, 38 and 39..... 26</li> <li>• Changed equations 47, 48, 49, 50, 51 and 53 ..... 28</li> <li>• Changed equations 58, 60, 61, 62 ..... 29</li> </ul>	<p>19</p> <p>19</p> <p>20</p> <p>21</p> <p>21</p> <p>21</p> <p>21</p> <p>25</p> <p>25</p> <p>25</p> <p>26</p> <p>26</p> <p>26</p> <p>28</p> <p>29</p>
---	---

## 5 Pin Configuration and Functions



### Pin Functions

PIN		I/O	DESCRIPTION
NAME	NO.		
BP	9	O	Regulator output pin. Connect a 1.0 $\mu$ F bypass capacitor from this pin to GND.
COMP	4	O	Error amplifier output. Connect control loop compensation network between COMP pin and FB pin.
DIS/ $\overline{\text{EN}}$	3	I	Disable pin. Pulling this pin high, places the part into a shutdown mode. Shutdown mode is characterized by a very low quiescent current. While in shutdown mode, the functionality of all blocks is disabled and the BP regulator is shut down. This pin has an internal 1 M $\Omega$ pull-down resistor to GND. Leaving this pin unconnected enables the device.
FB	5	I	Error amplifier inverting input. Connect a voltage divider from the output to this pin to set output voltage. Compensation network is connected between this pin and COMP.
GDRV	8	O	Connect the gate of the power N channel MOSFET to this pin.
GND	6	-	Device ground.
ISNS	7	I	Current sense pin. Connect an external current sensing resistor between this pin and GND. The voltage on this pin is used to provide current feedback in the control loop and detect an overcurrent condition. An overcurrent condition is declared when ISNS pin voltage exceeds the overcurrent threshold voltage, 150 mV typical.
RC	1	I	Switching frequency setting pin. Connect a resistor from RC pin to VDD of the IC power supply and a capacitor from RC to GND.
SS	2	I	Soft-start time programming pin. Connect capacitor from SS pin to GND to program converter soft-start time. This pin also functions as a timeout timer when the power supply is in an overcurrent condition.
VDD	10	I	System input voltage. Connect a local bypass capacitor from this pin to GND. Depending on the amount of required slope compensation, this pin can be connected to the converter output. See <a href="#">Application Information</a> section for additional details.

## 6 Specifications

### 6.1 Absolute Maximum Ratings

over operating free-air temperature range unless otherwise noted<sup>(1)</sup>

		MIN	MAX	UNIT
Input voltage	VDD	-0.3	52	V
	RC, SS, FB, DIS/ $\overline{\text{EN}}$	-0.3	10	
	ISNS	-0.3	8	
Output voltage	COMP, BP, GDRV	-0.3	9	
T <sub>J</sub>	Operating junction temperature	-40	150	°C
T <sub>stg</sub>	Storage temperature	-55	150	°C

(1) Stresses beyond those listed under [Absolute Maximum Ratings](#) may cause permanent damage to the device. These are stress ratings only, and functional operation of the device at these or any other conditions beyond those indicated under [Recommended Operating Conditions](#) is not implied. Exposure to absolute-maximum-rated conditions for extended periods may affect device reliability.

## 6.2 ESD Ratings

		VALUE	UNIT
V <sub>(ESD)</sub>	Electrostatic discharge	Human-body model (HBM), per ANSI/ESDA/JEDEC JS-001 <sup>(1)</sup>	±1500
		Charged-device model (CDM), per JEDEC specification JESD22-C101 <sup>(2)</sup>	±1500
			V

(1) JEDEC document JEP155 states that 500-V HBM allows safe manufacturing with a standard ESD control process.

(2) JEDEC document JEP157 states that 250-V CDM allows safe manufacturing with a standard ESD control process.

## 6.3 Recommended Operating Conditions

		MIN	MAX	UNIT
V <sub>DD</sub>	Input voltage	4.5	52	V
T <sub>J</sub>	Operating Junction temperature	-40	125	°C

## 6.4 Thermal Information

THERMAL METRIC <sup>(1)</sup>		TPS40210	TPS40211	UNIT
		HVSSOP	VSON	
		10 PINS	10 PINS	
R <sub>θJA</sub>	Junction-to-ambient thermal resistance	67.2	47.2	°C/W
R <sub>θJC(top)</sub>	Junction-to-case (top) thermal resistance	50.5	74.6	
R <sub>θJB</sub>	Junction-to-board thermal resistance	41.0	22.2	
ψ <sub>JT</sub>	Junction-to-top characterization parameter	2.4	2.9	
ψ <sub>JB</sub>	Junction-to-board characterization parameter	40.7	22.4	
R <sub>θJC(bot)</sub>	Junction-to-case (bottom) thermal resistance	15.6	8.8	

(1) For more information about traditional and new thermal metrics, see the *IC Package Thermal Metrics* application report, [SPRA953](#).

## 6.5 Electrical Characteristics

T<sub>J</sub> = -40°C to 125°C, V<sub>DD</sub> = 12V<sub>dc</sub>, all parameters at zero power dissipation (unless otherwise noted)

PARAMETER		TEST CONDITIONS		MIN	TYP	MAX	UNIT
<b>VOLTAGE REFERENCE</b>							
V <sub>FB</sub>	Feedback voltage range	TPS40210	COMP = FB, 4.5 ≤ V <sub>DD</sub> ≤ 52 V, T <sub>J</sub> = 25°C	693	700	707	mV
		TPS40211	COMP=FB, 4.5 ≤ V <sub>DD</sub> ≤ 52 V, T <sub>J</sub> = 25°C	254	260	266	
		TPS40210	COMP = FB, 4.5 ≤ V <sub>DD</sub> ≤ 52 V, -40°C ≤ T <sub>J</sub> ≤ 125°C	686	700	714	
		TPS40211	COMP = FB, 4.5 ≤ V <sub>DD</sub> ≤ 52 V, -40°C ≤ T <sub>J</sub> ≤ 125°C	250	260	270	
<b>INPUT SUPPLY</b>							
V <sub>DD</sub>	Input voltage range			4.5		52	V
I <sub>DD</sub>	Operating current	4.5 ≤ V <sub>DD</sub> ≤ 52 V, no switching, V <sub>DIS</sub> < 0.8			1.5	2.5	mA
		2.5 ≤ V <sub>DIS</sub> ≤ 7 V			10	20	μA
		V <sub>DD</sub> < V <sub>UVLO(on)</sub> , V <sub>DIS</sub> < 0.8				530	μA
<b>UNDERVOLTAGE LOCKOUT</b>							
V <sub>UVLO(on)</sub>	Turn on threshold voltage			4.00	4.25	4.50	V
V <sub>UVLO(hyst)</sub>	UVLO hysteresis			140	195	240	mV
<b>OSCILLATOR</b>							
f <sub>OSC</sub>	Oscillator frequency range <sup>(1)</sup>			35		1000	kHz
	Oscillator frequency	R <sub>RC</sub> = 182 kΩ, C <sub>RC</sub> = 330 pF		260	300	340	
Frequency line regulation		4.5 ≤ V <sub>DD</sub> ≤ 52 V		-20%		7%	
V <sub>SLP</sub>	Slope compensation ramp			520	620	720	mV

(1) Ensured by design. Not production tested.

**Electrical Characteristics (continued)**
 $T_J = -40^{\circ}\text{C}$  to  $125^{\circ}\text{C}$ ,  $V_{DD} = 12V_{dc}$ , all parameters at zero power dissipation (unless otherwise noted)

PARAMETER		TEST CONDITIONS	MIN	TYP	MAX	UNIT
<b>PWM</b>						
$t_{ON(min)}$	Minimum pulse width	$V_{DD} = 12\text{ V}^{(1)}$		275	400	ns
		$V_{DD} = 30\text{ V}$		90	200	
$t_{OFF(min)}$	Minimum off time			170	200	
$V_{VLY}$	Valley voltage			1.2		V
<b>SOFT-START</b>						
$V_{SS(ofst)}$	Offset voltage from SS pin to error amplifier input			700		mV
$R_{SS(chg)}$	Soft-start charge resistance		320	430	600	k $\Omega$
$R_{SS(dchg)}$	Soft-start discharge resistance		840	1200	1600	
<b>ERROR AMPLIFIER</b>						
GBWP	Unity gain bandwidth product <sup>(1)</sup>		1.5	3.0		MHz
$A_{OL}$	Open loop gain <sup>(1)</sup>		60	80		dB
$I_{B(FB)}$	Input bias current (current out of FB pin)			100	300	nA
$I_{COMP(src)}$	Output source current	$V_{FB} = 0.6\text{ V}$ , $V_{COMP} = 1\text{ V}$	100	250		$\mu\text{A}$
$I_{COMP(snk)}$	Output sink current	$V_{FB} = 1.2\text{ V}$ , $V_{COMP} = 1\text{ V}$	1.2	2.5		mA
<b>OVERCURRENT PROTECTION</b>						
$V_{ISNS(oc)}$	Overcurrent detection threshold (at ISNS pin)	$4.5 \leq V_{DD} < 52\text{ V}$ , $-40^{\circ}\text{C} \leq T_J \leq 125^{\circ}\text{C}$	120	150	180	mV
$D_{OC}$	Overcurrent duty cycle <sup>(1)</sup>				2%	
$V_{SS(rst)}$	Overcurrent reset threshold voltage (at SS pin)		100	150	350	mV
$T_{BLNK}$	Leading edge blanking <sup>(1)</sup>			75		ns
<b>CURRENT SENSE AMPLIFIER</b>						
$A_{CS}$	Current sense amplifier gain		4.2	5.6	7.2	V/V
$I_{B(ISNS)}$	Input bias current			1	3	$\mu\text{A}$
<b>DRIVER</b>						
$I_{GDRV(src)}$	Gate driver source current	$V_{GDRV} = 4\text{ V}$ , $T_J = 25^{\circ}\text{C}$	375	400		mA
$I_{GDRV(snk)}$	Gate driver sink current	$V_{GDRV} = 4\text{ V}$ , $T_J = 25^{\circ}\text{C}$	330	400		
<b>LINEAR REGULATOR</b>						
$V_{BP}$	Bypass voltage output	$0\text{ mA} < I_{BP} < 15\text{ mA}$	7	8	9	V
<b>DISABLE/ENABLE</b>						
$V_{DIS(en)}$	Turn-on voltage		0.7		1.3	V
$V_{DIS(hys)}$	Hysteresis voltage		25	130	220	mV
$R_{DIS}$	DIS pin pulldown resistance		0.7	1.1	1.5	M $\Omega$

## 6.6 Typical Characteristics

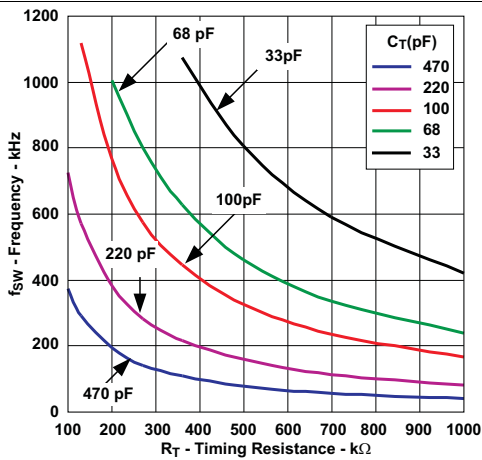


Figure 1. Frequency vs Timing Resistance

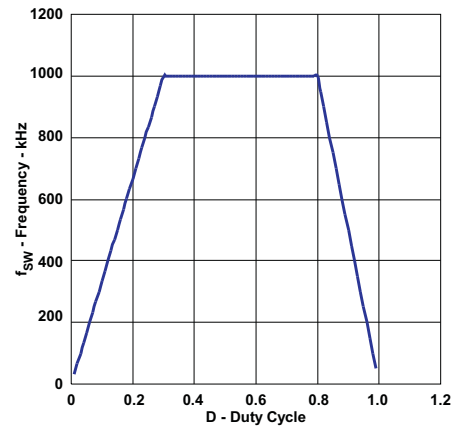


Figure 2. Switching Frequency vs Duty Cycle

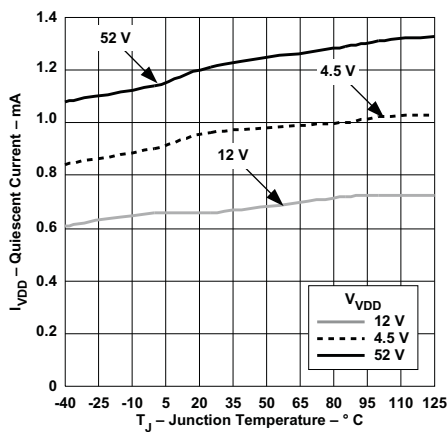


Figure 3. Quiescent Current vs Junction Temperature

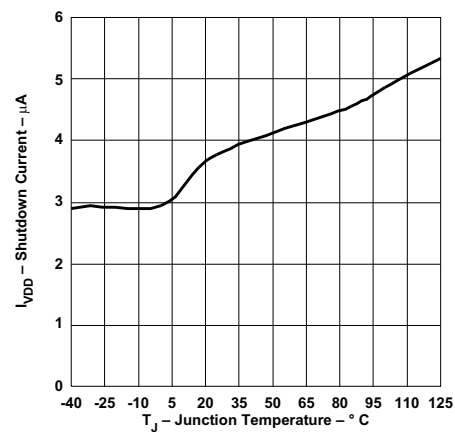


Figure 4. Shutdown Current vs Junction Temperature

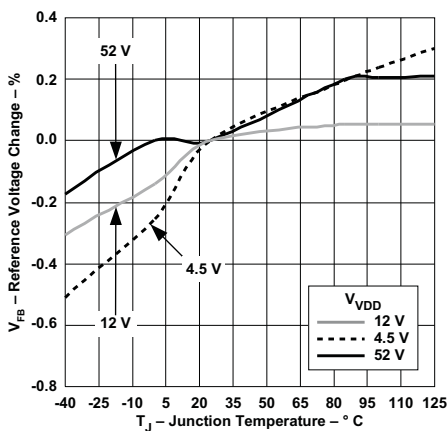


Figure 5. Reference Voltage Change vs Junction Temperature

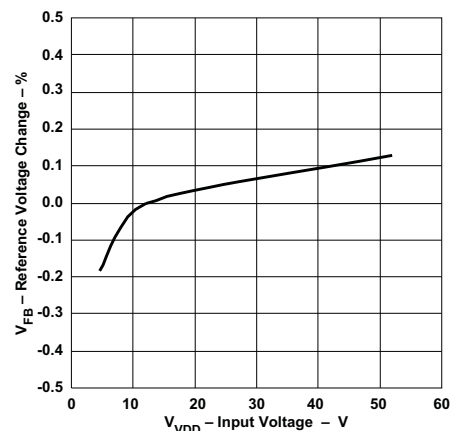


Figure 6. Reference Voltage Change vs Input Voltage

Typical Characteristics (continued)

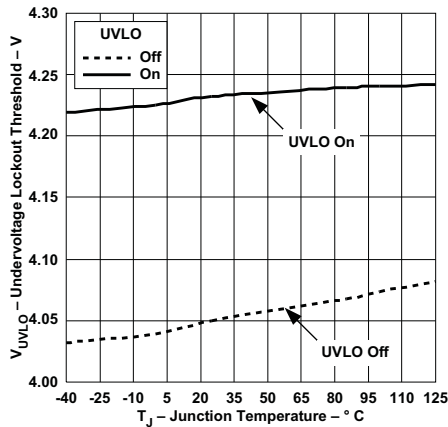


Figure 7. Undervoltage Lockout Threshold vs Junction Temperature

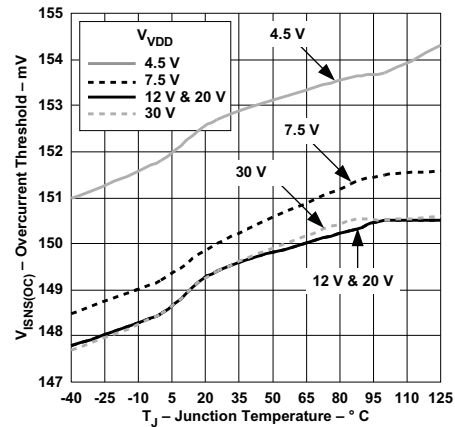


Figure 8. Overcurrent Threshold vs Junction Temperature

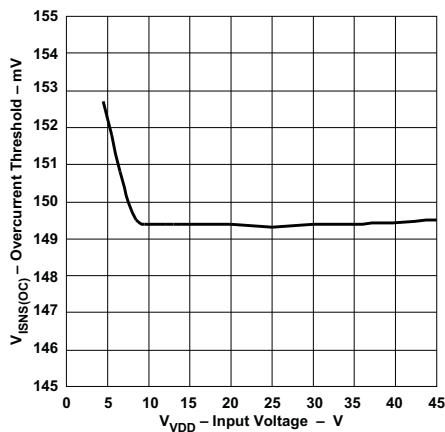


Figure 9. Overcurrent Threshold vs Input Voltage

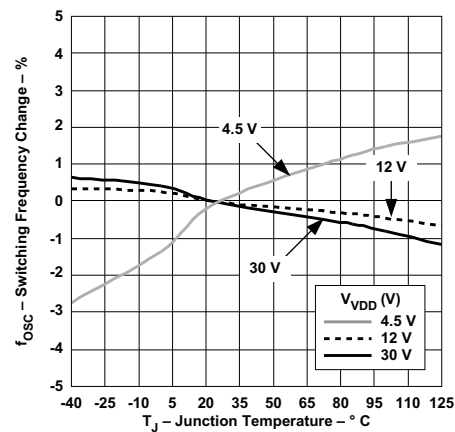


Figure 10. Switching Frequency Change vs Junction Temperature

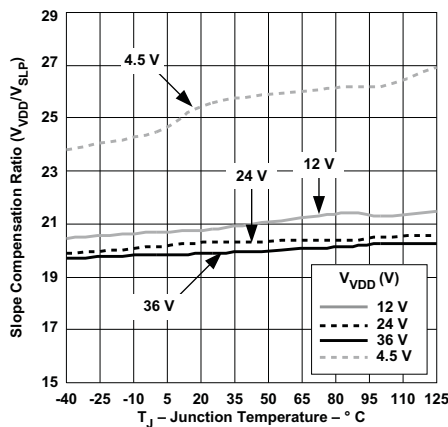


Figure 11. Oscillator Amplitude vs Junction Temperature

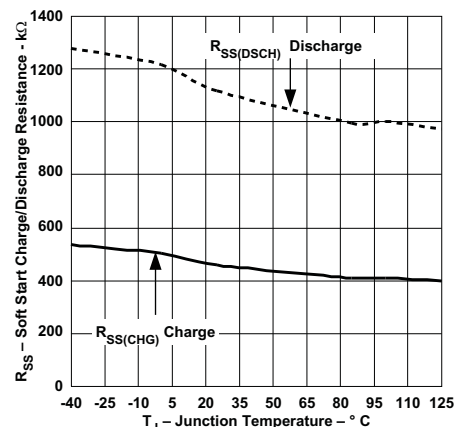


Figure 12. Soft-Start Charge/Discharge Resistance vs Junction Temperature

Typical Characteristics (continued)

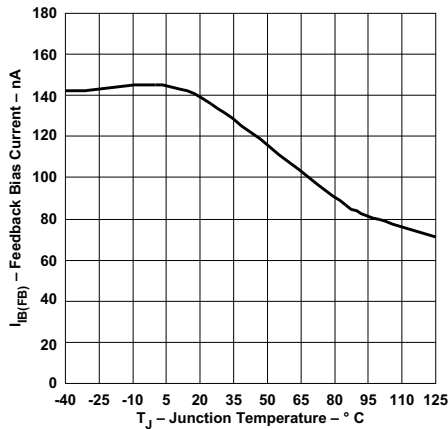


Figure 13. FB Bias Current vs Junction Temperature

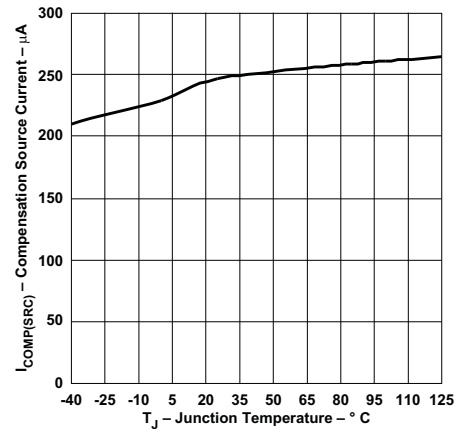


Figure 14. Compensation Source Current vs Junction Temperature

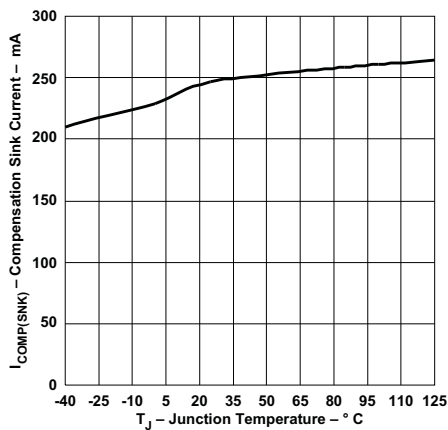


Figure 15. Compensation Sink Current vs Junction Temperature

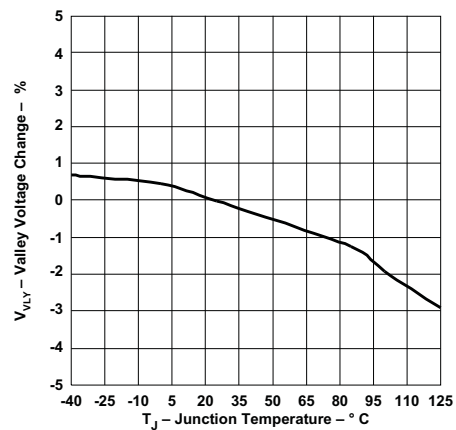


Figure 16. Valley Voltage Change vs Junction Temperature

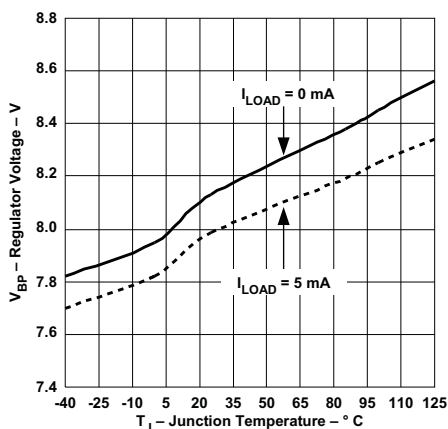


Figure 17. Regulator Voltage vs Junction Temperature

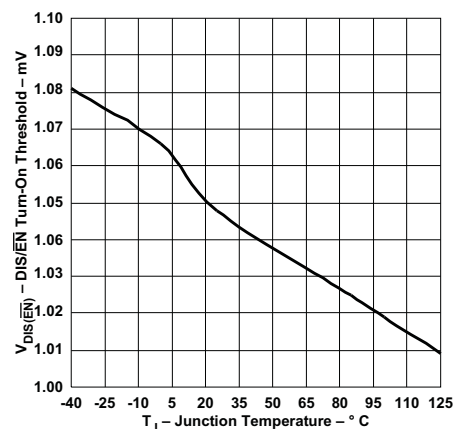
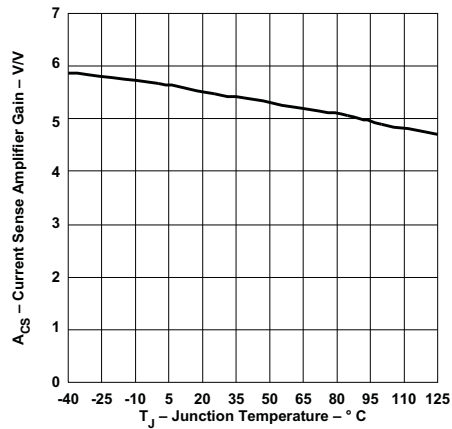


Figure 18. DIS/EN Turn-On Threshold vs Junction Temperature

**Typical Characteristics (continued)**



**Figure 19. Current Sense Amplifier Gain vs Junction Temperature**

## 7 Detailed Description

### 7.1 Overview

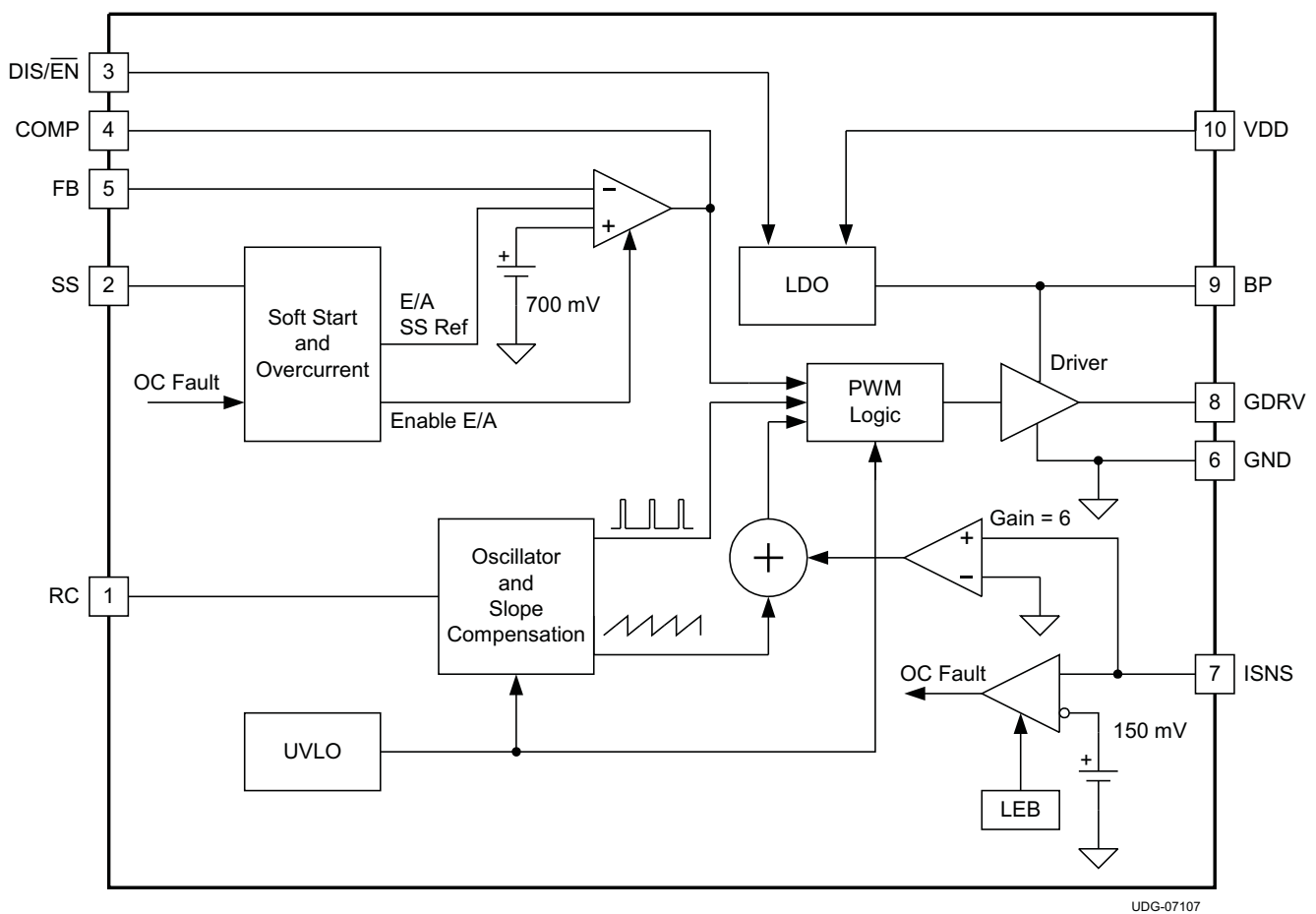
The TPS4021x is a peak current-mode control low-side controller with a built in 400-mA gate driver designed to drive n-channel MOSFETs at a fixed frequency. The frequency is adjustable from 35 kHz to 1000 kHz. Small size combined with complete functionality makes the part both versatile and easy to use.

The controller uses a low-value current-sensing resistor in series with the power MOSFET's source connection to detect switching current. When the voltage drop across this resistor exceeds 150 mV, the part enters an hiccup fault mode with a time period set by the external soft-start capacitor.

The TPS40210 uses voltage feedback to an error amplifier that is biased by a precision 700-mV reference. The TPS40211 has a lower 260-mV reference for higher efficiency in LED drive applications. Internal slope compensation eliminates the characteristic sub-harmonic instability of peak current mode control with duty cycles of 50% or greater.

The TPS4021x also incorporates a soft-start feature where the output follows a slowly rising soft-start voltage, preventing output-voltage overshoot. The DIS/EN disables the TPS40210 putting it in a low quiescent current shutdown mode.

### 7.2 Functional Block Diagram



## 7.3 Feature Description

### 7.3.1 Soft-Start

The soft-start feature of the TPS40210/11 is a closed-loop soft-start, meaning that the output voltage follows a linear ramp that is proportional to the ramp generated at the SS pin. This ramp is generated by an internal resistor connected from the BP pin to the SS pin and an external capacitor connected from the SS pin to GND. The SS pin voltage ( $V_{SS}$ ) is level shifted down by approximately  $V_{SS(ofst)}$  (approximately 700 mV) and sent to one of the “+” (the “+” input with the lowest voltage dominates) inputs of the error amplifier. When this level shifted voltage ( $V_{SSE}$ ) starts to rise at time  $t_1$  (see Figure 20), the output voltage the controller expects, rises as well. Since  $V_{SSE}$  starts at near 0 V, the controller attempts to regulate the output voltage from a starting point of zero volts. It cannot do this due to the converter architecture. The output voltage starts from the input voltage less the drop across the diode ( $V_{IN} - V_D$ ) and rises from there. The point at which the output voltage starts to rise ( $t_2$ ) is the point where the  $V_{SSE}$  ramp passes the point where it is commanding more output voltage than ( $V_{IN} - V_D$ ). This voltage level is labeled  $V_{SSE(1)}$ . The time required for the output voltage to ramp from a theoretical zero to the final regulated value (from  $t_1$  to  $t_3$ ) is determined by the time it takes for the capacitor connected to the SS pin ( $C_{SS}$ ) to rise through a 700-mV range, beginning at  $V_{SS(ofst)}$  above GND.

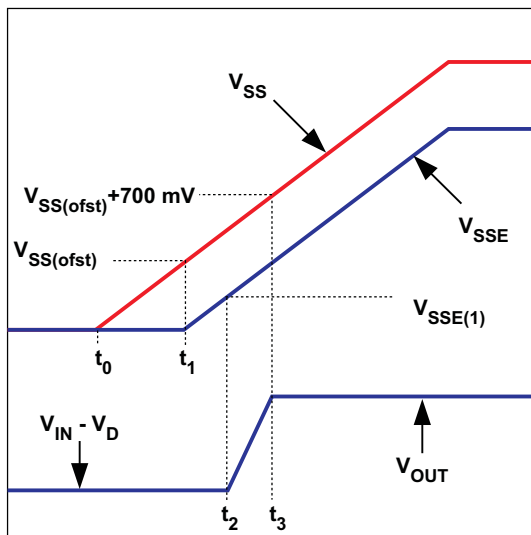


Figure 20. SS Pin Voltage and Output Voltage

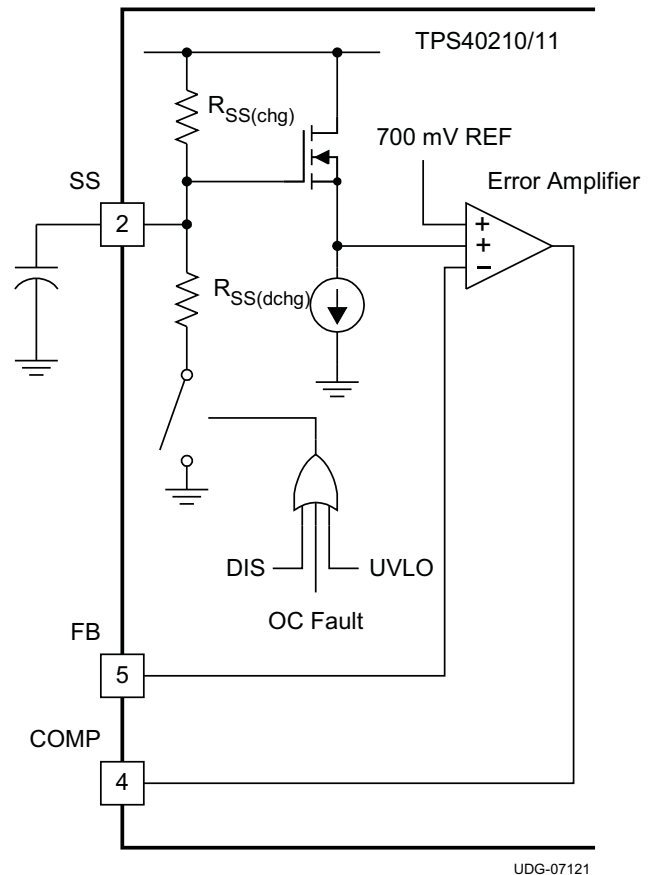


Figure 21. SS Pin Functional Circuit

## Feature Description (continued)

The required capacitance for a given soft-start time  $t_3 - t_1$  in [Figure 20](#) is calculated in [Equation 1](#).

$$C_{SS} = \frac{t_{SS}}{R_{SS} \times \ln \left( \frac{V_{BP} - V_{SS(ofst)}}{V_{BP} - (V_{SS(ofst)} + V_{FB})} \right)}$$

where

- $t_{SS}$  is the soft-start time, in seconds
  - $R_{SS(chg)}$  is the SS charging resistance in  $\Omega$ , typically 500 k $\Omega$
  - $C_{SS}$  is the value of the capacitor on the SS pin, in F
  - $V_{BP}$  is the value of the voltage on the BP pin, in V
  - $V_{SS(ofst)}$  is the approximate level shift from the SS pin to the error amplifier (~700 mV)
  - $V_{FB}$  is the error amplifier reference voltage, 700 mV typical
- (1)

Note that  $t_{SS}$  is the time it takes for the output voltage to rise from 0 V to the final output voltage. Also note the tolerance on  $R_{SS(chg)}$  given in the electrical specifications table. This contributes to some variability in the output voltage rise time and margin must be applied to account for it in design.

Also take note of  $V_{BP}$ . Its value varies depending on input conditions. For example, a converter operating from a slowly rising input initializes  $V_{BP}$  at a fairly low value and increases during the entire startup sequence. If the controller has a voltage above 8V at the input and the DIS pin is used to stop and then restart the converter,  $V_{BP}$  is approximately 8V for the entire startup sequence. The higher the voltage on BP, the shorter the startup time is and conversely, the lower the voltage on BP, the longer the startup time is.

The soft-start time ( $t_{SS}$ ) must be chosen long enough so that the converter can start up without going into an overcurrent state. Since the over current state is triggered by sensing the peak voltage on the ISNS pin, that voltage must be kept below the overcurrent threshold voltage  $V_{ISNS(oc)}$ . The voltage on the ISNS pin is a function of the load current of the converter, the rate of rise of the output voltage and the output capacitance, and the current sensing resistor. The total output current that must be supported by the converter is the sum of the charging current required by the output capacitor and any external load that must be supplied during startup. This current must be less than the  $I_{OUT(oc)}$  value used in [Equation 15](#) or [Equation 16](#) (depending on the operating mode of the converter) to determine the current sense resistor value. In these equations, the actual input voltage at the time that the controller reaches the final output voltage is the important input voltage to use in the calculations. If the input voltage is slowly rising and is at less than the nominal input voltage when the startup time ends, the output current limit is less than  $I_{OUT(oc)}$  at the nominal input voltage. The output capacitor charging current must be reduced (decrease  $C_{OUT}$  or increase the  $t_{SS}$ ) or  $I_{OUT(oc)}$  must be increased and a new value for  $R_{ISNS}$  calculated.

$$I_{C(chg)} = \left[ \frac{C_{OUT} \times V_{OUT}}{t_{SS}} \right]$$
(2)

$$t_{SS} > \left[ \frac{C_{OUT} \times V_{OUT}}{(I_{OUT(oc)} - I_{EXT})} \right]$$

where

- $I_{C(chg)}$  is the output capacitor charging current in A
  - $C_{OUT}$  is the total output capacitance in F
  - $V_{OUT}$  is the output voltage in V
  - $t_{SS}$  is the soft-start time from [Equation 1](#)
  - $I_{OUT(oc)}$  is the desired over current trip point in A
  - $I_{EXT}$  is any external load current in A
- (3)

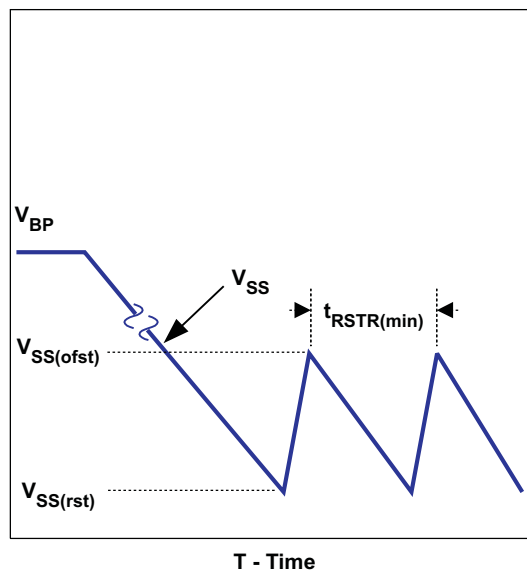
## Feature Description (continued)

The capacitor on the SS pin ( $C_{SS}$ ) also plays a role in overcurrent functionality. It is used as the timer between restart attempts. The SS pin is connected to GND through a resistor,  $R_{SS(dchg)}$ , whenever the controller senses an overcurrent condition. Switching stops and nothing else happens until the SS pin discharges to the soft-start reset threshold,  $V_{SS(rst)}$ . At this point, the SS pin capacitor is allowed to charge again through the charging resistor  $R_{SS(chg)}$ , and the controller restarts from that point. The shortest time between restart attempts occurs when the SS pin discharges from  $V_{SS(ofst)}$  (approximately 700 mV) to  $V_{SS(rst)}$  (150 mV) and then back to  $V_{SS(ofst)}$  and switching resumes. In actuality, this is a conservative estimate since switching does not resume until the  $V_{SSE}$  ramp rises to a point where it is commanding more output voltage than exists at the output of the controller. This occurs at some SS pin voltage greater than  $V_{SS(ofst)}$  and depends on the voltage that remains on the output overvoltage the converter while switching has been halted. The fastest restart time can be calculated by using [Equation 4](#), [Equation 5](#), and [Equation 6](#).

$$t_{DCHG} = R_{SS(dchg)} \times C_{SS} \times \ln \left( \frac{V_{SS(ofst)}}{V_{SS(rst)}} \right) \quad (4)$$

$$t_{CHG} = R_{SS(chg)} \times C_{SS} \times \ln \left( \frac{(V_{BP} - V_{SS(rst)})}{(V_{BP} - V_{SS(ofst)})} \right) \quad (5)$$

$$t_{RSTRT(min)} = t_{CHG} + t_{DCHG} \quad (6)$$



**Figure 22. Soft-Start during Overcurrent**

### 7.3.2 BP Regulator

The TPS40210/11 has an on board linear regulator that supplies power for the internal circuitry of the controller, including the gate driver. This regulator has a nominal output voltage of 8 V and must be bypassed with a 1- $\mu$ F capacitor. If the voltage at the VDD pin is less than 8 V, the voltage on the BP pin will also be less and the gate drive voltage to the external FET is reduced from the nominal 8 V. This should be considered when choosing a FET for the converter.

## Feature Description (continued)

Connecting external loads to this regulator can be done, but care must be taken to ensure that the thermal rating of the device is observed since there is no thermal shutdown feature in this controller. Exceeding the thermal ratings cause out of specification behavior and can lead to reduced reliability. The controller dissipates more power when there is an external load on the BP pin and is tested for dropout voltage for up to 5mA load. When the controller is in the disabled state, the BP pin regulator also shuts off so loads connected there power down as well. When the controller is disabled with the DIS/EN pin, this regulator is turned off.

The total power dissipation in the controller can be calculated as follows. The total power is the sum of  $P_Q$ ,  $P_G$  and  $P_E$ .

$$P_Q = V_{VDD} \times I_{VDD(en)} \quad (7)$$

$$P_G = V_{VDD} \times Q_g \times f_{SW} \quad (8)$$

$$P_E = V_{VDD} \times I_{EXT}$$

where

- $P_Q$  is the quiescent power of the device in W
- $V_{DD}$  is the VDD pin voltage in V
- $I_{DD(en)}$  is the quiescent current of the controller when enabled but not switching in A
- $P_G$  is the power dissipated by driving the gate of the FET in W
- $Q_g$  is the total gate charge of the FET at the voltage on the BP pin in C
- $f_{SW}$  is the switching frequency in Hz
- $P_E$  is the dissipation caused by external loading of the BP pin in W
- $I_{EXT}$  is the external load current in A

### 7.3.3 Shutdown (DIS/ $\overline{EN}$ Pin)

The DIS/ $\overline{EN}$  pin is an active high shutdown command for the controller. Pulling this pin above 1.2 V causes the controller to completely shut down and enter a low current consumption state. In this state, the regulator connected to the BP pin is turned off. There is an internal 1.1-M $\Omega$  pulldown resistor connected to this pin that keeps the pin at GND level when left floating. If this function is not used in an application, it is best to connect this pin to GND.

### 7.3.4 Minimum On-Time and Off-Time Considerations

The TPS40210 has a minimum off-time of approximately 200 ns and a minimum on-time of 300 ns. These two constraints place limitations on the operating frequency that can be used for a given input to output conversion ratio. See [Figure 2](#) for the maximum frequency that can be used for a given duty cycle.

The duty cycle at which the converter operates is dependent on the mode in which the converter is running. If the converter is running in discontinuous conduction mode, the duty cycle varies with changes to the load much more than it does when running in continuous conduction mode.

In continuous conduction mode, the duty cycle is related primarily to the input and output voltages.

$$\frac{V_{OUT} + V_D}{V_{IN}} = \frac{1}{1-D} \quad (10)$$

$$D = \left( 1 - \left( \frac{V_{IN}}{V_{OUT} + V_D} \right) \right) \quad (11)$$

In discontinuous mode the duty cycle is a function of the load, input and output voltages, inductance and switching frequency.

$$D = \frac{2 \times (V_{OUT} + V_D) \times I_{OUT} \times L \times f_{SW}}{(V_{IN})^2} \quad (12)$$

## Feature Description (continued)

All converters using a diode as the freewheeling or catch component have a load current level at which they transition from discontinuous conduction to continuous conduction. This is the point where the inductor current just falls to zero. At higher load currents, the inductor current does not fall to zero but remains flowing in a positive direction and assumes a trapezoidal wave shape as opposed to a triangular wave shape. This load boundary between discontinuous conduction and continuous conduction can be found for a set of converter parameters as follows.

$$I_{OUT(crit)} = \frac{(V_{OUT} + V_D - V_{IN}) \times (V_{IN})^2}{2 \times (V_{OUT} + V_D)^2 \times f_{SW} \times L} \quad (13)$$

For loads higher than the result of Equation 13, the duty cycle is given by Equation 11 and for loads less than the results of Equation 13, the duty cycle is given Equation 12. For Equations 1 through 4, the variable definitions are as follows.

- $V_{OUT}$  is the output voltage of the converter in V
- $V_D$  is the forward conduction voltage drop across the rectifier or catch diode in V
- $V_{IN}$  is the input voltage to the converter in V
- $I_{OUT}$  is the output current of the converter in A
- L is the inductor value in H
- $f_{SW}$  is the switching frequency in Hz

### 7.3.5 Setting the Oscillator Frequency

The oscillator frequency is determined by a resistor and capacitor connected to the RC pin of the TPS40210. The capacitor is charged to a level of approximately  $V_{DD}/20$  by current flowing through the resistor and is then discharged by a transistor internal to the TPS40210. The required resistor for a given oscillator frequency is found from either Figure 1 or Equation 14.

$$R_T = \frac{1}{5.8 \times 10^{-8} \times f_{SW} \times C_T + 8 \times 10^{-10} \times f_{SW}^2 + 1.4 \times 10^{-7} \times f_{SW} - 1.5 \times 10^{-4} + 1.7 \times 10^{-6} \times C_T - 4 \times 10^{-9} \times C_T^2}$$

where

- $R_T$  is the timing resistance in k $\Omega$
  - $f_{SW}$  is the switching frequency in kHz
  - $C_T$  is the timing capacitance in pF
- (14)

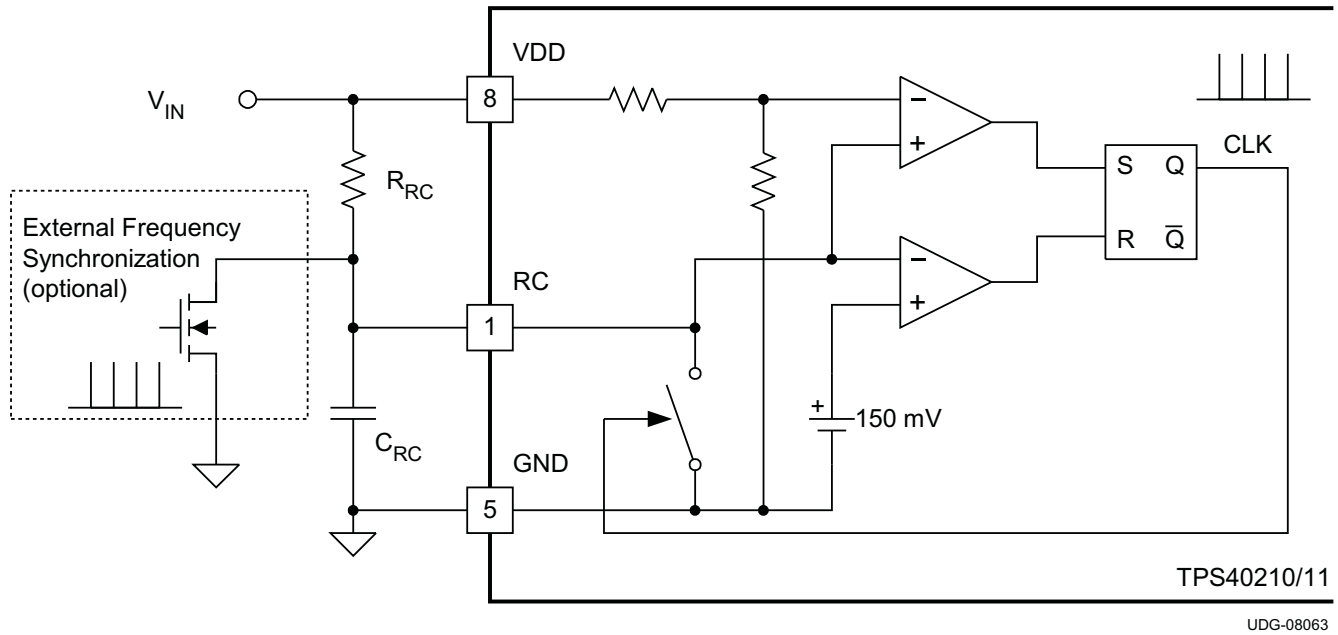
For most applications a capacitor in the range of 68 pF to 120 pF gives the best results. Resistor values should be limited to between 100 k $\Omega$  and 1 M $\Omega$  as well. If the resistor value falls below 100 k $\Omega$ , decrease the capacitor size and recalculate the resistor value for the desired frequency. As the capacitor size decreases below 47 pF, the accuracy of Equation 14 degrades and empirical means may be needed to fine tune the timing component values to achieve the desired switching frequency.

### 7.3.6 Synchronizing the Oscillator

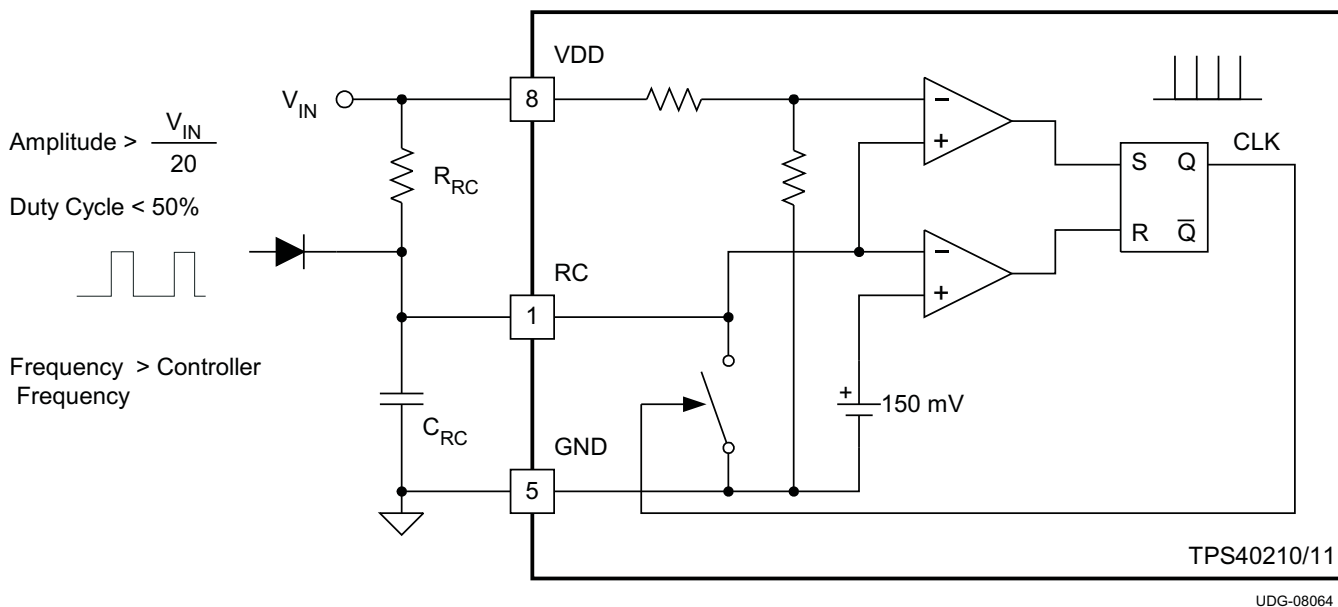
The TPS40210 and TPS40211 can be synchronized to an external clock source. Figure 23 shows the functional diagram of the oscillator. When synchronizing the oscillator to an external clock, the RC pin must be pulled below 150 mV for 20 ns or more. The external clock frequency must be higher than the free running frequency of the converter as well. When synchronizing the controller, if the RC pin is held low for an excessive amount of time, erratic operation may occur. The maximum amount of time that the RC pin should be held low is 50% of a nominal output pulse, or 10% of the period of the synchronization frequency. If the external clock signal cannot operate with a low enough duty cycle to limit the amount of time the RC pin is held low, a resistor and capacitor can be added at the gate of the synchronization MOSFET. The capacitor should be added in series with the gate of the MOSFET to AC couple the rising edge of the synchronization signal. The resistor should be added from the gate of the MOSFET to ground to turn off the MOSFET. Typical values for the resistor and capacitor are 220 pF and 1 k $\Omega$ .

**Feature Description (continued)**

Under circumstances where the duty cycle is less than 50%, a Schottky diode connected from the RC pin to an external clock may be used to synchronize the oscillator. The cathode of the diode is connected to the RC pin. The trip point of the oscillator is set by an internal voltage divider to be 1/20 of the input voltage. The clock signal must have an amplitude higher than this trip point. When the clock goes low, it allows the reset current to restart the RC ramp, synchronizing the oscillator to the external clock. This provides a simple, single-component method for clock synchronization.



**Figure 23. Oscillator Functional Diagram**



**Figure 24. Diode Connected Synchronization**

## Feature Description (continued)

### 7.3.7 Current Sense and Overcurrent

The TPS4021x is a current mode controller that uses a resistor in series with the source terminal power FET to sense current for both the current mode control and overcurrent protection. The device enters a current limit state if the voltage on the ISNS pin exceeds the current limit threshold voltage  $V_{ISNS(oc)}$  from the electrical specifications table. When this happens the controller discharges the SS capacitor through a relatively high impedance and then attempt to restart. The amount of output current that causes this to happen is dependent on several variables in the converter.

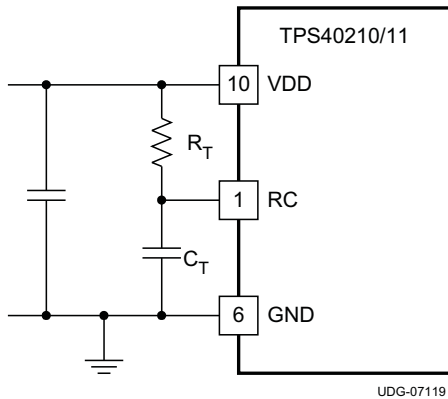


Figure 25. Oscillator Components

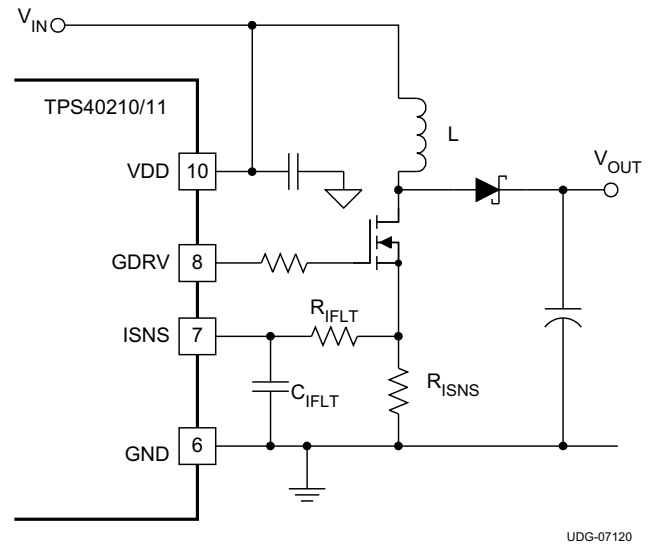


Figure 26. Current Sense Components

The load current overcurrent threshold is set by proper choice of  $R_{ISNS}$ . If the converter is operating in discontinuous mode the current sense resistor is found in Equation 15.

$$R_{ISNS} = \frac{f_{SW} \times L \times V_{ISNS(oc)}}{\sqrt{2 \times L \times f_{SW} \times I_{OUT(oc)} \times (V_{OUT} + V_D - V_{IN})}} \quad (15)$$

If the converter is operating in continuous conduction mode  $R_{ISNS}$  can be found in Equation 16.

$$R_{ISNS} = \frac{V_{ISNS}}{\left(\frac{I_{OUT}}{1-D}\right) + \left(\frac{I_{RIPPLE}}{2}\right)} = \frac{V_{ISNS}}{\left(\frac{I_{OUT}}{(1-D)}\right) + \left(\frac{D \times V_{IN}}{2 \times f_{SW} \times L}\right)}$$

where

- $R_{ISNS}$  is the value of the current sense resistor in  $\Omega$ .
- $V_{ISNS(oc)}$  is the overcurrent threshold voltage at the ISNS pin (from electrical specifications)
- $D$  is the duty cycle (from Equation 11)
- $f_{SW}$  is the switching frequency in Hz
- $V_{IN}$  is the input voltage to the power stage in V (see text)
- $L$  is the value of the inductor in H
- $I_{OUT(oc)}$  is the desired overcurrent trip point in A
- $V_D$  is the drop across the diode in Figure 26

(16)

## Feature Description (continued)

The TPS40210/11 has a fixed undervoltage lockout (UVLO) that allows the controller to start at a typical input voltage of 4.25 V. If the input voltage is slowly rising, the converter might have less than its designed nominal input voltage available when it has reached regulation. As a result, this may decrease the apparent current limit load current value and must be taken into consideration when selecting  $R_{ISNS}$ . The value of  $V_{IN}$  used to calculate  $R_{ISNS}$  must be the value at which the converter finishes startup. The total converter output current at startup is the sum of the external load current and the current required to charge the output capacitor(s). See the [Soft-Start](#) section of this datasheet for information on calculating the required output capacitor charging current.

The topology of the standard boost converter has no method to limit current from the input to the output in the event of a short circuit fault on the output of the converter. If protection from this type of event is desired, it is necessary to use some secondary protection scheme, such as a fuse, or rely on the current limit of the upstream power source.

### 7.3.8 Current Sense and Sub-Harmonic Instability

A characteristic of peak current mode control results in a condition where the current control loop can exhibit instability. This results in alternating long and short pulses from the pulse width modulator. The voltage loop maintains regulation and does not oscillate, but the output ripple voltage increases. The condition occurs only when the converter is operating in continuous conduction mode and the duty cycle is 50% or greater. The cause of this condition is described in Texas Instruments literature number [SLUA101](#), available at [www.ti.com](http://www.ti.com). The remedy for this condition is to apply a compensating ramp from the oscillator to the signal going to the pulse width modulator. In the TPS40210/11 the oscillator ramp is applied in a fixed amount to the pulse width modulator. The slope of the ramp is given in [Equation 17](#).

$$s_e = f_{SW} \times \left( \frac{V_{VDD}}{20} \right) \quad (17)$$

To ensure that the converter does not enter into sub-harmonic instability, the slope of the compensating ramp signal must be at least half of the down slope of the current ramp signal. Since the compensating ramp is fixed in the TPS40210/11, this places a constraint on the selection of the current sense resistor.

The down slope of the current sense wave form at the pulse width modulator is described in [Equation 18](#).

$$m_2 = \frac{A_{CS} \times R_{ISNS} \times (V_{OUT} + V_D - V_{IN})}{L} \quad (18)$$

Since the slope compensation ramp must be at least half, and preferably equal to the down slope of the current sense waveform seen at the pulse width modulator, a maximum value is placed on the current sense resistor when operating in continuous mode at 50% duty cycle or greater. For design purposes, some margin should be applied to the actual value of the current sense resistor. As a starting point, the actual resistor chosen should be 80% or less that the value calculated in [Equation 19](#). This equation calculates the resistor value that makes the slope compensation ramp equal to one half of the current ramp downslope. Values no more than 80% of this result would be acceptable.

$$R_{ISNS(max)} = \frac{V_{VDD} \times L \times f_{SW}}{60 \times (V_{OUT} + V_D - V_{IN})}$$

where

- $S_e$  is the slope of the voltage compensating ramp applied to the pulse width modulator in V/s
- $f_{SW}$  is the switching frequency in Hz
- $V_{DD}$  is the voltage at the VDD pin in V
- $m_2$  is the down slope of the current sense waveform seen at the pulse width modulator in V/s
- $R_{ISNS}$  is the value of the current sense resistor in  $\Omega$
- $V_{OUT}$  is the converter output voltage  $V_{IN}$  is the converter power stage input voltage
- $V_D$  is the drop across the diode in [Figure 26](#)

(19)

## Feature Description (continued)

It is possible to increase the voltage compensation ramp slope by connecting the VDD pin to the output voltage of the converter instead of the input voltage as shown in [Figure 26](#). This can help in situations where the converter design calls for a large ripple current value in relation to the desired output current limit setting.

### NOTE

Connecting the VDD pin to the output voltage of the converter affects the startup voltage of the converter since the controller undervoltage lockout (UVLO) circuit monitors the VDD pin and senses the input voltage less the diode drop before startup. The effect is to increase the startup voltage by the value of the diode voltage drop.

If an acceptable  $R_{ISNS}$  value is not available, the next higher value can be used and the signal from the resistor divided down to an acceptable level by placing another resistor in parallel with  $C_{IFLT}$ .

### 7.3.9 Current Sense Filtering

In most cases, a small filter placed on the ISNS pin improves performance of the converter. These are the components  $R_{IFLT}$  and  $C_{IFLT}$  in [Figure 26](#). The time constant of this filter should be approximately 10% of the nominal pulse width of the converter. The pulse width can be found using [Equation 20](#).

$$t_{ON} = \frac{D}{f_{SW}} \quad (20)$$

The suggested time constant is then

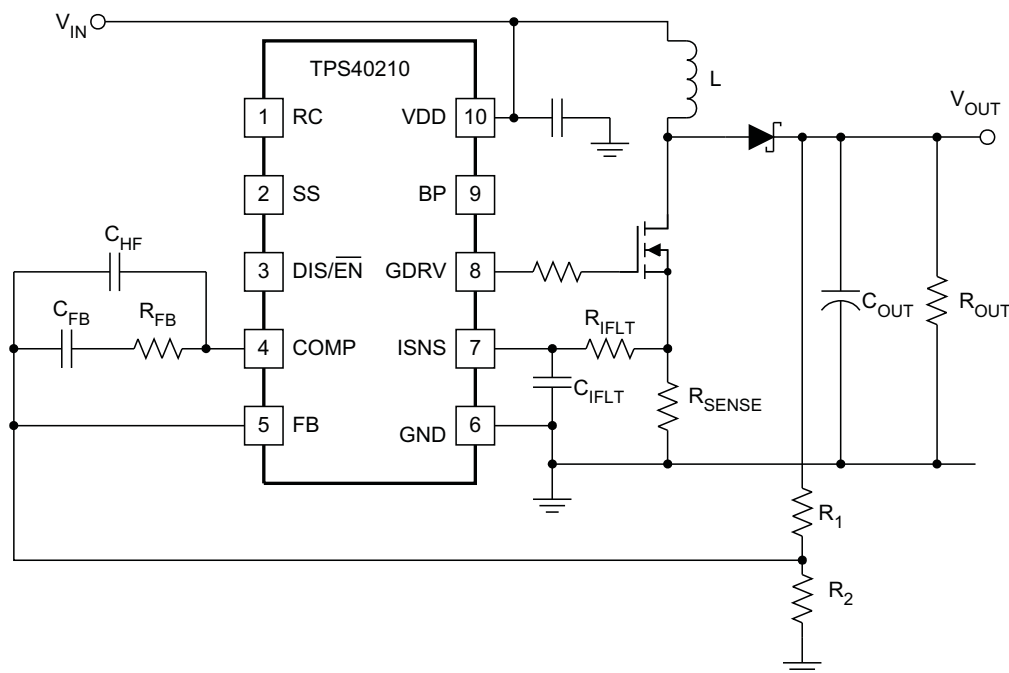
$$R_{IFLT} \times C_{IFLT} = 0.1 \times t_{ON} \quad (21)$$

The range of  $R_{IFLT}$  should be from about 1 k $\Omega$  to 5 k $\Omega$  for best results. Higher values can be used but this raises the impedance of the ISNS pin connection more than necessary and can lead to noise pickup issues in some layouts.  $C_{IFLT}$  should be located as close as possible to the ISNS pin as well to provide noise immunity.

### 7.3.10 Control Loop Considerations

There are two methods to design a suitable control loop for the TPS4021x. The first and preferred if equipment is available is to use a frequency response analyzer to measure the open loop modulator and power stage gain and to then design compensation to fit that. The usage of these tools for this purpose is well documented with the literature that accompanies the tool and is not be discussed here.

The second option is to make an initial guess at compensation, and then evaluate the transient response of the system to see if the compensation is acceptable to the application or not. For most systems, an adequate response can be obtained by simply placing a series resistor and capacitor ( $R_{FB}$  and  $C_{FB}$ ) from the COMP pin to the FB pin as shown in [Figure 27](#). The initial compensation selection can be done more accurately with aid of WEBENCH<sup>®</sup> to select the components or the average Spice model to simulate the open loop modulator and power stage gain.

**Feature Description (continued)**


UDG-07177

**Figure 27. Basic Compensation Network**

The natural phase characteristics of most capacitors used for boost outputs combined with the current mode control provide adequate phase margin when using this type of compensation. To determine an initial starting point for the compensation, the desired crossover frequency must be considered when estimating the control to output gain. The model used is a current source into the output capacitor and load.

When using these equations, the loop bandwidth should be no more than 20% of the switching frequency,  $f_{SW}$ . A more reasonable loop bandwidth would be 10% of the switching frequency. Be sure to evaluate the transient response of the converter over the expected load range to ensure acceptable operation.

$$|K_{CO}| = g_M \times |Z_{OUT}(f_{CO})| \quad (22)$$

$$g_M = \frac{0.13 \times \sqrt{L \times \frac{f_{SW}}{R_{OUT}}}}{(R_{ISNS})^2 \times (120 \times R_{ISNS} + L \times f_{SW})} \quad (23)$$

$$|Z_{OUT}| = R_{OUT} \times \sqrt{\frac{(1 + (2\pi \times f_L \times R_{ESR} \times C_{OUT})^2)}{1 + ((R_{OUT})^2 + 2 \times R_{OUT} \times R_{ESR} + (R_{ESR})^2) \times (2\pi \times f_L \times C_{OUT})^2}}$$

where

- $K_{CO}$  is the control to output gain of the converter, in V/V
- $g_M$  is the transconductance of the power stage and modulator, in S
- $R_{OUT}$  is the output load equivalent resistance, in  $\Omega$
- $Z_{OUT}$  is the output impedance, including the output capacitor, in  $\Omega$
- $R_{ISNS}$  is the value of the current sense resistor, in  $\Omega$
- $L$  is the value of the inductor, in H

## Feature Description (continued)

- $C_{OUT}$  is the value of the output capacitance, in F
- $R_{ESR}$  is the equivalent series resistance of  $C_{OUT}$ , in  $\Omega$
- $f_{SW}$  is the switching frequency, in Hz
- $f_L$  is the desired crossover frequency for the control loop, in Hz

(24)

These equations assume that the operation is discontinuous and that the load is purely resistive. The gain in continuous conduction can be found by evaluating [Equation 23](#) at the resistance that gives the critical conduction current for the converter. Loads that are more like current sources give slightly higher gains than predicted here. To find the gain of the compensation network required for a control loop of bandwidth  $f_L$ , take the reciprocal of [Equation 22](#).

$$K_{COMP} = \frac{1}{|K_{CO}|} \quad (25)$$

The GBWP of the error amplifier is only guaranteed to be at least 1.5MHz. If  $K_{COMP}$  multiplied by  $f_L$  is greater than 750 kHz, reduce the desired loop crossover frequency until this condition is satisfied. This ensures that the high-frequency pole from the error amplifier response with the compensation network in place does not cause excessive phase lag at  $f_L$  and decreased phase margin in the loop.

The RC network connected from COMP to FB places a zero in the compensation response. That zero should be approximately 1/10th of the desired crossover frequency,  $f_L$ . With that being the case,  $R_{FB}$  and  $C_{FB}$  can be found from [Equation 26](#) and [Equation 27](#)

$$R_{FB} = \frac{R1}{|K_{CO}|} = R1 \times K_{COMP} \quad (26)$$

$$C_{FB} = \frac{10}{2\pi \times f_L \times R_{FB}}$$

where

- R1 is the high side feedback resistor in [Figure 27](#), in  $\Omega$
- $f_L$  is the desired loop crossover frequency, in Hz

(27)

Thought not strictly necessary, it is recommended that a capacitor be added between COMP and FB to provide high-frequency noise attenuation in the control loop circuit. This capacitor introduces another pole in the compensation response. The allowable location of that pole frequency determines the capacitor value. As a starting point, the pole frequency should be  $10 \times f_L$ . The value of  $C_{HF}$  can be found from [Equation 28](#).

$$C_{HF} = \frac{1}{20\pi \times f_L \times R_{FB}} \quad (28)$$

While the error amplifier GBWP will usually be higher, it can be as low as 1.5MHz. If  $10 \times K_{Comp} \times f_L > 1.5\text{MHz}$ , the error amplifier gain-bandwidth product may limit the high-frequency response below that of the high-frequency capacitor. To maintain a consistent high-frequency gain roll-off,  $C_{HF}$  can be calculated by [Equation 29](#).

$$C_{HF} = \frac{1}{2\pi \times 1.5 \times (10)^6 \times R_{FB}}$$

where

- $C_{HF}$  is the high-frequency roll-off capacitor value in F
- $R_{FB}$  is the mid band gain setting resistor value in  $\Omega$

(29)

## Feature Description (continued)

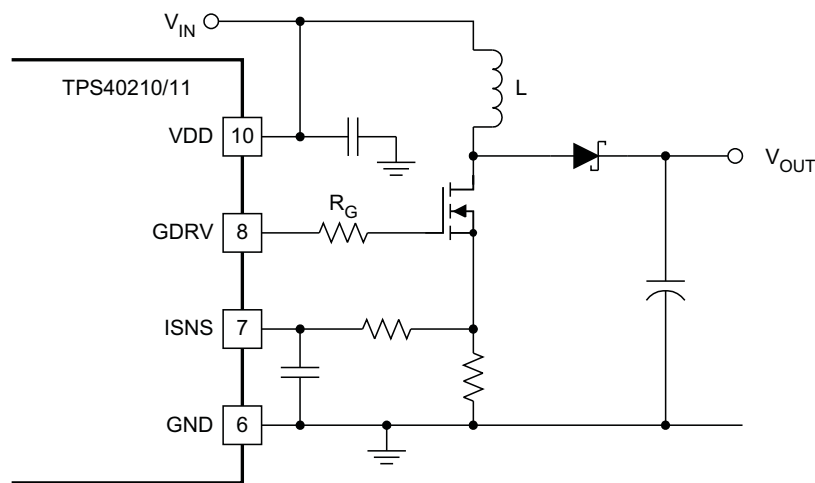
### 7.3.11 Gate Drive Circuit

Some applications benefit from the addition of a resistor connected between the GDRV pin and the gate of the switching MOSFET. In applications that have particularly stringent load regulation (under 0.75%) requirements and operate from input voltages above 5 V, or are sensitive to pulse jitter in the discontinuous conduction region, this resistor is recommended. The recommended starting point for the value of this resistor can be calculated from [Equation 30](#).

$$R_G = \frac{105}{Q_G}$$

where

- $Q_G$  is the MOSFET total gate charge at 8V,  $V_{GS}$  in nC
- $R_G$  is the suggested starting point gate resistance in  $\Omega$  (30)



UDG-07196

**Figure 28. Gate Drive Resistor**

### 7.3.12 TPS40211

The only difference between the TPS40210 and the TPS40211 is the reference voltage that the error amplifier uses to regulate the output voltage. The TPS40211 uses a 260-mV reference and is intended for applications where the output is actually a current instead of a regulated voltage. A typical example of an application of this type is an LED driver. An example schematic is shown in [Figure 29](#).

## Feature Description (continued)

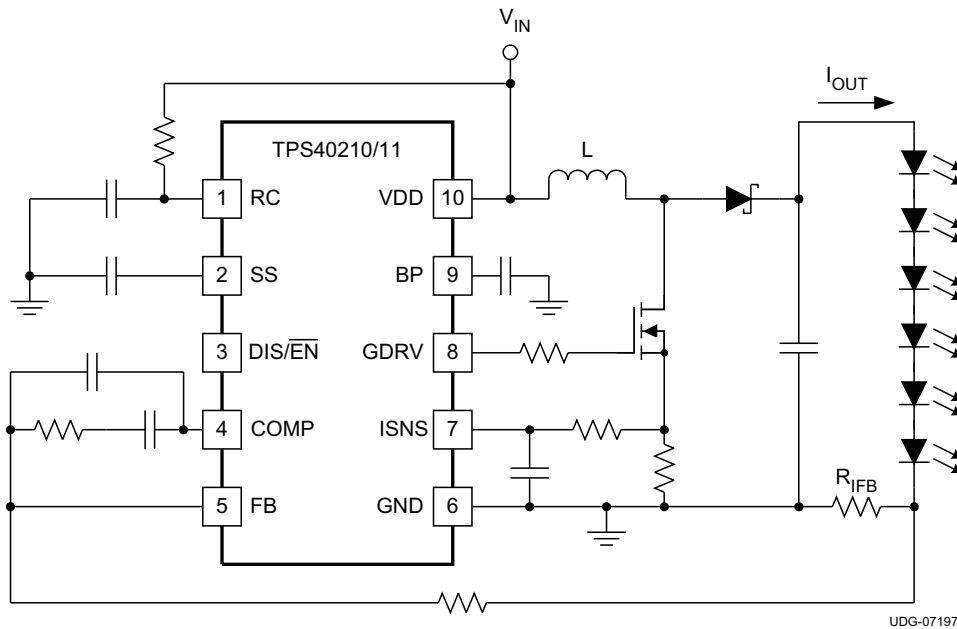


Figure 29. Typical LED Drive Schematic

The current in the LED string is set by the choice of the resistor  $R_{ISNS}$  as shown in Equation 31.

$$R_{IFB} = \frac{V_{FB}}{I_{OUT}}$$

where

- $R_{IFB}$  is the value of the current sense resistor for the LED string in  $\Omega$
- $V_{FB}$  is the reference voltage for the TPS40211 in V (0.260V typ.)
- $I_{OUT}$  is the desired DC current in the LED string in A

(31)

## 7.4 Device Functional Modes

### 7.4.1 Operation Near Minimum Input Voltage

The TPS4021x is designed to operate with input voltages above 4.5 V. The typical VDD UVLO threshold is 4.25 V and the device may operate at input voltages down to the UVLO voltage. At input voltages below the actual UVLO voltage, the device will not switch. When  $V_{VDD}$  passes the UVLO threshold the device will become active. Switching is enabled and the soft-start sequence is initiated. The TPS4021x will ramp up the output voltage at the rate determined by the external capacitor at the soft-start pin.

### 7.4.2 Operation With DIS/EN Pin

The DIS/EN pin has a 1.2-V typical threshold which can be used to disable the TPS4021x. With DIS/EN forced above this threshold voltage the device is disabled and switching is inhibited even if  $V_{VDD}$  is above its UVLO threshold. Hysteresis on the DIS/EN pin threshold gives a typical turn-on threshold of 1.05 V. If the DIS/EN is left floating or is pulled below the 1.05-V threshold while  $V_{VDD}$  is above its UVLO threshold, the device becomes active. Switching is enabled and the soft-start sequence is initiated. The TPS4021x will ramp up the output voltage at the rate determined by the external capacitor at the soft-start pin.

## 8 Application and Implementation

### NOTE

Information in the following applications sections is not part of the TI component specification, and TI does not warrant its accuracy or completeness. TI's customers are responsible for determining suitability of components for their purposes. Customers should validate and test their design implementation to confirm system functionality.

### 8.1 Application Information

The TPS4021x is a 4.5-V to 52-V low-side controller with an integrated gate driver for a low-side N-channel MOSFET. This device is typically used in a boost topology to convert a lower DC voltage to a higher DC voltage with a peak current limit set by an external current sense resistor. It can also be configured in a SEPIC, Flyback and LED drive applications. In higher current applications, the maximum current can also be limited by the thermal performance of the external MOSFET and rectifying diode switch. Use the following design procedure to select external components for the TPS4021x. The design procedure illustrates the design of a typical boost regulator with the TPS40210. Alternatively, use the WEBENCH software to generate a complete design. The WEBENCH software uses an iterative design procedure and accesses a comprehensive database of components when generating a design.

### 8.2 Typical Applications

#### 8.2.1 12-V to 24-V Nonsynchronous Boost Regulator

The following example illustrates the design process and component selection for a 12-V to 24-V nonsynchronous boost regulator using the TPS40210 controller.

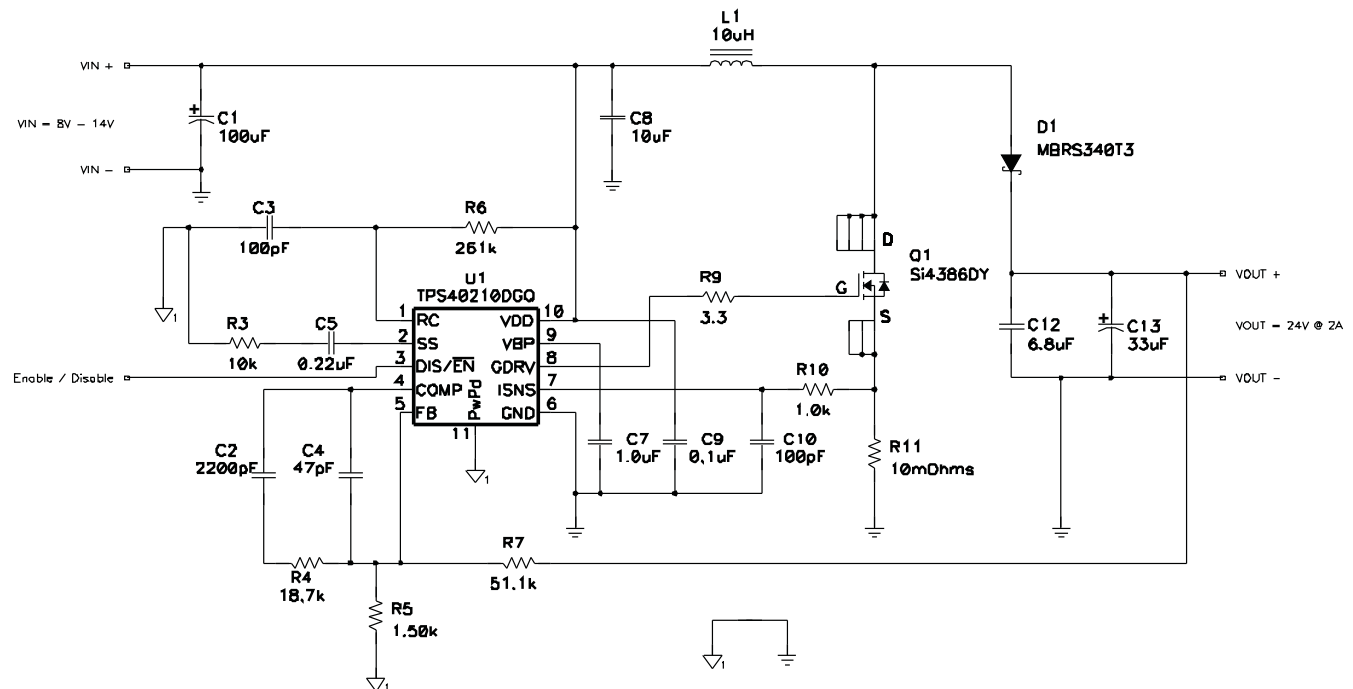


Figure 30. TPS40210 Design Example – 12-V to 24-V at 2 A

## Typical Applications (continued)

### 8.2.1.1 Design Requirements

**Table 1. TPS40210 Design Example Specifications**

PARAMETER		TEST CONDITIONS	MIN	TYP	MAX	UNIT
<b>INPUT CHARACTERISTICS</b>						
$V_{IN}$	Input voltage		8	12	14	V
$I_{IN}$	Input current		4.4			A
	No load input current		0.05			
$V_{IN(UVLO)}$	Input undervoltage lockout		4.5			V
<b>OUTPUT CHARACTERISTICS</b>						
$V_{OUT}$	Output voltage		23.5	24.0	24.5	V
	Line regulation		1%			
	Load regulation		1%			
$V_{OUT(ripple)}$	Output voltage ripple		500			mV <sub>PP</sub>
$I_{OUT}$	Output current	$8\text{ V} \leq V_{IN} \leq 14\text{ V}$	0.1	1	2.0	A
$I_{OCP}$	Output overcurrent inception point		3.5			
	Transient response					
$\Delta I$	Load step		1			A
	Load slew rate		1			A/ $\mu$ s
	Overshoot threshold voltage		500			mV
	Settling time		5			ms
<b>SYSTEM CHARACTERISTICS</b>						
$f_{SW}$	Switching frequency		600			kHz
$\eta_{PK}$	Peak efficiency	$V_{IN} = 12\text{ V}$	95%			
$\eta$	Full load efficiency	$V_{IN} = 12\text{ V}, I_{OUT} = 2\text{ A}$	94%			
$T_{OP}$	Operating temperature range	$8\text{ V} \leq V_{IN} \leq 14\text{ V}, I_{OUT} \leq 2\text{ A}$	25			°C
<b>MECHANICAL DIMENSIONS</b>						
W	Width		1.5			inch
L	Length		1.5			
h	Height		0.5			

### 8.2.1.2 Detailed Design Procedure

#### 8.2.1.2.1 Custom Design with WEBENCH Tools

[Click here](#) to create a custom design using the TPS40210 device with the WEBENCH® Power Designer.

1. Start by entering your  $V_{IN}$ ,  $V_{OUT}$  and  $I_{OUT}$  requirements.
2. Optimize your design for key parameters like efficiency, footprint and cost using the optimizer dial and compare this design with other possible solutions from Texas Instruments.
3. WEBENCH Power Designer provides you with a customized schematic along with a list of materials with real time pricing and component availability.
4. In most cases, you will also be able to:
  - Run electrical simulations to see important waveforms and circuit performance,
  - Run thermal simulations to understand the thermal performance of your board,
  - Export your customized schematic and layout into popular CAD formats,
  - Print PDF reports for the design, and share your design with colleagues.
5. Get more information about WEBENCH tools at [www.ti.com/webench](http://www.ti.com/webench).

#### 8.2.1.2.2 Duty Cycle Estimation

The duty cycle of the main switching MOSFET is estimated using [Equation 32](#) and [Equation 33](#).

**Typical Applications (continued)**

$$D_{\text{MIN}} \approx \frac{V_{\text{OUT}} - V_{\text{IN(max)}} + V_{\text{FD}}}{V_{\text{OUT}} + V_{\text{FD}}} = \frac{24\text{ V} - 14\text{ V} + 0.5\text{ V}}{24\text{ V} + 0.5\text{ V}} = 42.9\% \quad (32)$$

$$D_{\text{MAX}} \approx \frac{V_{\text{OUT}} - V_{\text{IN(min)}} + V_{\text{FD}}}{V_{\text{OUT}} + V_{\text{FD}}} = \frac{24\text{ V} - 8\text{ V} + 0.5\text{ V}}{24\text{ V} + 0.5\text{ V}} = 67.3\% \quad (33)$$

Using an estimated forward drop ( $V_{\text{FD}}$ ) of 0.5V for a schottky rectifier diode, the approximate duty cycle is 42.9% (minimum) to 67.3% (maximum).

**8.2.1.2.3 Inductor Selection**

The peak-to-peak ripple is chosen to be 30% of the maximum input current.

$$I_{\text{RIPPLE(max)}} = 0.3 \times \frac{I_{\text{OUT(max)}}}{1 - D_{\text{MIN}}} = 0.3 \times \frac{2}{1 - 0.429} = 1.05\text{ A} \quad (34)$$

## Typical Applications (continued)

The minimum inductor size can be estimated using [Equation 35](#).

$$L_{\text{MIN}} \approx \frac{V_{\text{IN(max)}}}{I_{\text{RIPPLE(max)}}} \times D_{\text{MIN}} \times \frac{1}{f_{\text{SW}}} = \frac{14\text{ V}}{1.05\text{ A}} \times 0.429 \times \frac{1}{600\text{ kHz}} = 9.5\text{ }\mu\text{H} \quad (35)$$

The next higher standard inductor value of 10  $\mu\text{H}$  is selected. The ripple current for nominal and minimum  $V_{\text{IN}}$  is estimated by [Equation 36](#) and [Equation 37](#).

$$I_{\text{RIPPLE}(V_{\text{in,typ}})} \approx \frac{V_{\text{IN}}}{L} \times D \times \frac{1}{f_{\text{SW}}} = \frac{12\text{ V}}{10\text{ }\mu\text{H}} \times 0.50 \times \frac{1}{600\text{ kHz}} = 1.02\text{ A} \quad (36)$$

$$I_{\text{RIPPLE}(V_{\text{inmin}})} \approx \frac{V_{\text{IN}}}{L} \times D \times \frac{1}{f_{\text{SW}}} = \frac{8\text{ V}}{10\text{ }\mu\text{H}} \times 0.673 \times \frac{1}{600\text{ kHz}} = 0.90\text{ A} \quad (37)$$

The worst case peak-to-peak ripple current occurs at 50% duty cycle ( $V_{\text{IN}} = 12.25\text{ V}$ ) and is estimated as 1.02A. Worst case RMS current through the inductor is approximated by [Equation 38](#).

$$I_{\text{Lrms}} = \sqrt{\left(I_{\text{L(avg)}}\right)^2 + \left(\frac{1}{\sqrt{2}}I_{\text{RIPPLE}}\right)^2} \approx \sqrt{\left(\frac{I_{\text{OUT(max)}}}{1-D_{\text{MAX}}}\right)^2 + \left(\frac{1}{\sqrt{2}}I_{\text{RIPPLE}(V_{\text{inmin}})}\right)^2} = \sqrt{\left(\frac{2}{1-0.673}\right)^2 + \left(\frac{1}{\sqrt{2}} \times 0.90\text{ A}\right)^2} = 6.13\text{ Arms} \quad (38)$$

The worst case RMS inductor current is 6.13 Arms. The peak inductor current is estimated by [Equation 39](#).

$$I_{\text{Lpeak}} \approx \frac{I_{\text{OUT(max)}}}{1-D_{\text{MAX}}} + \left(\frac{1}{\sqrt{2}}\right)I_{\text{RIPPLE}(V_{\text{inmin}})} = \frac{2}{1-0.673} + \left(\frac{1}{\sqrt{2}}\right)0.90 = 6.57\text{ A} \quad (39)$$

A 10- $\mu\text{H}$  inductor with a minimum RMS current rating of 6.13A and minimum saturation current rating of 6.57 A must be selected. A TDK RLF12560T-100M-7R5 7.5-A 10- $\mu\text{H}$  inductor is selected.

This inductor power dissipation is estimated by [Equation 40](#).

$$P_{\text{L}} \approx \left(I_{\text{Lrms}}\right)^2 \times \text{DCR} \quad (40)$$

The TDK RLF12560T-100M-7R5 12.4-m $\Omega$  DCR dissipates 466-mW of power.

### 8.2.1.2.4 Rectifier Diode Selection

A low forward voltage drop schottky diode is used as a rectifier diode to reduce its power dissipation and improve efficiency. Using 80% derating on  $V_{\text{OUT}}$  for ringing on the switch node, the rectifier diode minimum reverse breakdown voltage is given by [Equation 41](#).

$$V_{(\text{BR})\text{R(min)}} \geq \frac{V_{\text{OUT}}}{0.8} = 1.25 \times V_{\text{OUT}} = 1.25 \times 24\text{ V} = 30\text{ V} \quad (41)$$

The diode must have reverse breakdown voltage greater than 30 V. The rectifier diode peak and average currents are estimated by [Equation 42](#) and [Equation 43](#).

$$I_{\text{D(avg)}} \approx I_{\text{OUT(max)}} = 2\text{ A} \quad (42)$$

$$I_{\text{D(peak)}} = I_{\text{L(peak)}} = 6.57\text{ A} \quad (43)$$

The power dissipation in the diode is estimated by [Equation 44](#).

$$P_{\text{D(max)}} \approx V_{\text{FD}} \times I_{\text{D(avg)}} = 0.5\text{ V} \times 2\text{ A} = 1\text{ W} \quad (44)$$

For this design, the maximum power dissipation is estimated as 1 W. Reviewing 30-V and 40-V schottky diodes, the MBRS340T3, 40-V, 3-A diode in an SMC package is selected. This diode has a forward voltage drop of 0.48 V at 6 A, so the conduction power dissipation is approximately 960 mW, less than half its rated power dissipation.

## Typical Applications (continued)

### 8.2.1.2.5 Output Capacitor Selection

Output capacitors must be selected to meet the required output ripple and transient specifications.

$$C_{OUT} = 8 \frac{I_{OUT} \times D}{V_{OUT(ripple)}} \times \frac{1}{f_{SW}} = 8 \left( \frac{2A \times 0.673}{500mV} \right) \times \frac{1}{600kHz} = 36\mu F \quad (45)$$

$$ESR = \frac{7}{8} \times \frac{V_{OUT(ripple)}}{I_{L(peak)} - I_{OUT}} = \frac{7}{8} \times \frac{500mV}{6.57A - 2A} = 96m\Omega \quad (46)$$

A Panasonic EEEFC1V330P 35-V 33- $\mu$ F, 120-m $\Omega$  bulk capacitor and a 6.8- $\mu$ F ceramic capacitor are selected to provide the required capacitance and ESR at the switching frequency. The combined capacitance of 39.8  $\mu$ F and ESR of 60 m $\Omega$  are used in compensation calculations.

### 8.2.1.2.6 Input Capacitor Selection

Since a boost converter has continuous input current, the input capacitor senses only the inductor ripple current. The input capacitor value can be calculated by [Equation 47](#) and [Equation 48](#).

$$C_{IN} > \frac{I_{RIPPLE}}{4 \times V_{IN(ripple)} \times f_{SW}} = \frac{1.02A}{4 \times 60mV \times 600kHz} = 7.1\mu F \quad (47)$$

$$ESR < \frac{V_{IN(ripple)}}{2 \times I_{RIPPLE}} = \frac{60mV}{2 \times 1.02A} = 29m\Omega \quad (48)$$

For this design to meet a maximum input ripple of 60mV (1/2% of  $V_{IN}$  nominal), a minimum 7.1- $\mu$ F input capacitor with ESR less than 29m $\Omega$  is needed. A 10- $\mu$ F, X7R ceramic capacitor is selected.

### 8.2.1.2.7 Current Sense and Current Limit

The maximum allowable current sense resistor value is limited by both the current limit and sub-harmonic stability. These two limitations are given by [Equation 49](#) and [Equation 50](#).

$$R_{ISNS} < \frac{V_{ISNS(OC)MIN}}{1.1 \times (I_{L(peak)} + I_{Drive})} = \frac{120mV}{1.1 \times (6.57A + 0.50A)} = 15.4m\Omega \quad (49)$$

$$R_{ISNS} < \frac{V_{IN(MAX)} \times L \times f_{SW}}{60 \times (V_{OUT} + V_{FD} - V_{IN})} = \frac{14V \times 10\mu H \times 600kHz}{60 \times (24V + 0.48V - 14V)} = 134m\Omega \quad (50)$$

With 10% margin on the current limit trip point (the 1.1 factor) and assuming a maximum gate drive current of 500 mA, the current limit requires a resistor less than 15.4 m $\Omega$  and stability requires a sense resistor less than 134 m $\Omega$ . A 10-m $\Omega$  resistor is selected. Approximately 2 m $\Omega$  of routing resistance is added in compensation calculations.

The power dissipation in  $R_{ISNS}$  is calculated by [Equation 51](#).

$$P_{R_{ISNS}} = (I_{LRMS})^2 \cdot R_{ISNS} \cdot D \quad (51)$$

At maximum duty cycle, this is 0.253 W.

### 8.2.1.2.8 Current Sense Filter

To remove switching noise from the current sense, an RC filter is placed between the current sense resistor and the ISNS pin. A resistor with a value between 1 k $\Omega$  and 5 k $\Omega$  is selected and a capacitor value is calculated by [Equation 52](#).

$$C_{IFLT} = \frac{0.1 \times D_{MIN}}{f_{SW} \times R_{IFLT}} = \frac{0.1 \times 0.429}{600kHz \times 1k\Omega} = 71pF \quad (52)$$

For a 1-k $\Omega$  filter resistor, 71pF is calculated and a 100-pF capacitor is selected.

## Typical Applications (continued)

### 8.2.1.2.9 Switching MOSFET Selection

The TPS40210 drives a ground referenced N-channel FET. The  $R_{DS(on)}$  and gate charge are estimated based on the desired efficiency target.

$$P_{DISS(total)} \approx P_{OUT} \times \left( \frac{1}{\eta} - 1 \right) = V_{OUT} \times I_{OUT} \times \left( \frac{1}{\eta} - 1 \right) = 24 \text{ V} \times 2 \text{ A} \times \left( \frac{1}{0.95} - 1 \right) = 2.526 \text{ W} \quad (53)$$

For a target of 95% efficiency with a 24-V Input voltage at 2 A, maximum power dissipation is limited to 2.526 W. The main power dissipating devices are the MOSFET, inductor, diode, current sense resistor and the integrated circuit, the TPS40210.

$$P_{FET} < P_{DISS(total)} - P_L - P_D - P_{Risns} - V_{IN(max)} \times I_{VDD(max)} \quad (54)$$

This leaves 812 mW of power dissipation for the MOSFET. This can likely cause an SO-8 MOSFET to get too hot, so power dissipation is limited to 500 mW. Allowing half for conduction and half for switching losses, we can determine a target  $R_{DS(on)}$  and  $Q_{GS}$  for the MOSFET by [Equation 55](#) and [Equation 56](#).

$$Q_{GS} < \frac{3 \times P_{FET} \times I_{DRIVE}}{2 \times V_{OUT} \times I_{OUT} \times f_{SW}} = \frac{3 \times 0.50 \text{ W} \times 0.50 \text{ A}}{2 \times 24 \text{ V} \times 2 \text{ A} \times 600 \text{ kHz}} = 13.0 \text{ nC} \quad (55)$$

A target MOSFET gate-to-source charge of less than 13.0 nC is calculated to limit the switching losses to less than 250 mW.

$$R_{DS(on)} < \frac{P_{FET}}{2 \times (I_{RMS})^2 \times D} = \frac{0.50 \text{ W}}{2 \times 6.13^2 \times 0.673} = 9.9 \text{ m}\Omega \quad (56)$$

A target MOSFET  $R_{DS(on)}$  of 9.9 m $\Omega$  is calculated to limit the conduction losses to less than 250 mW. Reviewing 30-V and 40-V MOSFETs, an Si4386DY 9-m $\Omega$  MOSFET is selected. A gate resistor was added per [Equation 30](#). The maximum gate charge at  $V_{GS} = 8 \text{ V}$  for the Si4386DY is 33.2 nC, this implies  $R_G = 3.3 \Omega$ .

### 8.2.1.2.10 Feedback Divider Resistors

The primary feedback divider resistor ( $R_{FB}$ ) from  $V_{OUT}$  to FB should be selected between 10 k $\Omega$  and 100 k $\Omega$  to maintain a balance between power dissipation and noise sensitivity. For a 24-V output a high feedback resistance is desirable to limit power dissipation so  $R_{FB} = 51.1 \text{ k}\Omega$  is selected.

$$R_{BIAS} = \frac{V_{FB} \times R_{FB}}{V_{OUT} - V_{FB}} = \frac{0.700 \text{ V} \times 51.1 \text{ k}\Omega}{24 \text{ V} - 0.700 \text{ V}} = 1.53 \text{ k}\Omega \quad (57)$$

$R_{BIAS} = 1.50 \text{ k}\Omega$  is selected.

### 8.2.1.2.11 Error Amplifier Compensation

Compensation selection can be done with aid of WEBENCH to select compensation components or with the aid of the average Spice model to simulate the open loop modulator and power stage gain. Alternatively the following procedure gives a good starting point.

While current mode control typically only requires Type II compensation, it is desirable to layout for Type III compensation to increase flexibility during design and development. Current mode control boost converters have higher gain with higher output impedance, so it is necessary to calculate the control loop gain at the maximum output impedance, estimated by [Equation 58](#).

$$R_{OUT(max)} = \frac{V_{OUT}}{I_{OUT(min)}} = \frac{24 \text{ V}}{0.1 \text{ A}} = 240 \Omega \quad (58)$$

## Typical Applications (continued)

The transconductance of the TPS40210 current mode control can be estimated by [Equation 59](#).

$$g_M = \frac{0.13 \times \sqrt{L \times \frac{f_{SW}}{R_{OUT}}}}{(R_{ISNS})^2 \times (120 \times R_{ISNS} + L \times f_{SW})} = \frac{0.13 \times \sqrt{10 \mu\text{H} \times \frac{600 \text{kHz}}{240 \Omega}}}{(12 \text{m}\Omega)^2 \times (120 \times 12 \text{m}\Omega + 10 \mu\text{H} \times 600 \text{kHz})} = 19.2 \text{ A/V} \quad (59)$$

The maximum output impedance  $Z_{OUT}$ , can be estimated by [Equation 60](#).

$$|Z_{OUT}(f)| = R_{OUT} \times \sqrt{\frac{(1 + (2\pi \times f \times R_{ESR} \times C_{OUT})^2)}{1 + ((R_{OUT})^2 + 2 \times R_{OUT} \times R_{ESR} + (R_{ESR})^2) \times (2\pi \times f \times C_{OUT})^2}} \quad (60)$$

$$|Z_{OUT}(f_L)| = 240 \Omega \times \sqrt{\frac{(1 + (2\pi \times 30 \text{kHz} \times 60 \text{m}\Omega \times 39.8 \mu\text{F})^2)}{1 + ((240 \Omega)^2 + 2 \times 240 \Omega \times 60 \text{m}\Omega + (60 \text{m}\Omega)^2) \times (2\pi \times 30 \text{kHz} \times 39.8 \mu\text{F})^2}} = 0.146 \Omega \quad (61)$$

At the desired crossover frequency ( $f_L$ ) of 30 kHz,  $Z_{OUT}$  becomes 0.146  $\Omega$ .

The modulator gain at the desired cross-over can be estimated by [Equation 62](#).

$$|K_{CO}| = g_M \times |Z_{OUT}(f_{CO})| = 19.2 \text{ A/V} \times 0.146 \Omega = 2.80 \quad (62)$$

The feedback compensation network needs to be designed to provide an inverse gain at the cross-over frequency for unity loop gain. This sets the compensation mid-band gain at a value calculated in [Equation 63](#).

$$K_{COMP} = \frac{1}{|K_{CO}|} = \frac{1}{2.80} = 0.357 \quad (63)$$

To set the mid-band gain of the error amplifier to  $K_{COMP}$  use [Equation 64](#).

$$R4 = R7 \times K_{COMP} = \frac{R7}{|K_{CO}|} = \frac{51.1 \text{k}\Omega}{2.80} = 18.2 \text{k}\Omega \quad (64)$$

R4 = 18.7 k $\Omega$  selected.

Place the zero at 1/10th of the desired cross-over frequency.

$$C2 = \frac{10}{2\pi \times f_L \times R4} = \frac{10}{2\pi \times 30 \text{kHz} \times 18.7 \text{k}\Omega} = 2837 \text{pF} \quad (65)$$

C2 = 2200 pF selected.

Place a high-frequency pole at about 5 times the desired cross-over frequency and less than one-half the unity gain bandwidth of the error amplifier:

$$C4 \approx \frac{1}{10\pi \times f_L \times R4} = \frac{1}{10\pi \times 30 \text{kHz} \times 18.7 \text{k}\Omega} = 56.74 \text{pF} \quad (66)$$

$$C4 > \frac{1}{\pi \times \text{GBW} \times R4} = \frac{1}{\pi \times 1.5 \text{MHz} \times 18.7 \text{k}\Omega} = 11.35 \text{pF} \quad (67)$$

C4 = 47 pF selected.

### 8.2.1.2.12 RC Oscillator

The RC oscillator calculation is given as shown in [Equation 14](#) in the datasheet, substituting 100 for  $C_T$  and 600 for  $f_{SW}$ . For a 600-kHz switching frequency, a 100pF capacitor is selected and a 262-k $\Omega$  resistor is calculated (261-k $\Omega$  selected).

## Typical Applications (continued)

### 8.2.1.2.13 Soft-Start Capacitor

Since  $V_{DD} > 8\text{ V}$ , the soft-start capacitor is selected by using [Equation 68](#) to calculate the value.

$$C_{SS} = 20 \times T_{SS} \times 10^{-6} \quad (68)$$

For  $T_{SS} = 12\text{ ms}$ ,  $C_{SS} = 240\text{ nF}$ . A 220-nF capacitor is selected.

### 8.2.1.2.14 Regulator Bypass

A regulator bypass (BP) capacitor of  $1.0\text{ }\mu\text{F}$  is selected per the datasheet recommendation.

### 8.2.1.2.15 Bill of Materials

**Table 2. Bill of Materials**

REFERENCE DESIGNATOR	DESCRIPTION	SIZE	PART NUMBER	MANUFACTURER
C1	100 $\mu\text{F}$ , aluminum capacitor, SM, $\pm 20\%$ , 35 V	0.406 x 0.457	EEEF1V101P	Panasonic
C2	2200 pF, ceramic capacitor, 25 V, X7R, 20%	0603	Std	Std
C3	100 pF, ceramic capacitor, 16 V, C0G, 10%	0603	Std	Std
C4	47 pF, ceramic capacitor, 16V, X7R, 20%	0603	Std	Std
C5	0.22 $\mu\text{F}$ , ceramic capacitor, 16 V, X7R, 20%	0603	Std	Std
C7	1.0 $\mu\text{F}$ , ceramic capacitor, 16 V, X5R, 20%	0603	Std	Std
C8	10 $\mu\text{F}$ , ceramic capacitor, 25 V, X7R, 20%	0805	C3225X7R1E106M	TDK
C9	0.1 $\mu\text{F}$ , ceramic capacitor, 50 V, X7R, 20%	0603	Std	Std
C10	100 pF, ceramic capacitor, 16 V, X7R, 20%	0603	Std	Std
D1	Schottky diode, 3 A, 40 V	SMC	MBRS340T3	On Semi
L1	10 $\mu\text{H}$ , inductor, SMT, 7.5 A, 12.4 m $\Omega$	0.325 x 0.318 inch	RLF12560T-100M-7R5	TDK
Q1	MOSFET, N-channel, 40 V, 14 A, 9m $\Omega$	SO-8	Si4840DY	Vishay
R3	10 k $\Omega$ , chip resistor, 1/16 W, 5%	0603	Std	Std
R4	18.7 k $\Omega$ , chip resistor, 1/16 W, 1%	0603	Std	Std
R5	1.5 k $\Omega$ , chip resistor, 1/16 W, 1%	0603	Std	Std
R6	261 k $\Omega$ , chip resistor, 1/16 W, 1%	0603	Std	Std
R7	51.1 k $\Omega$ , chip resistor, 1/16 W, 1%	0603	Std	Std
R9	3.3 $\Omega$ , chip resistor, 1/16 W, 5%	0603	Std	Std
R10	1.0 k $\Omega$ , chip resistor, 1/16 W, 5%	0603	Std	Std
R11	10 m $\Omega$ , chip resistor, 1/2 W, 2%	1812	Std	Std
U1	IC, 4.5 V-52 V I/P, current mode boost controller	DGQ10	TPS40210DGQ	TI

8.2.1.3 Application Curves

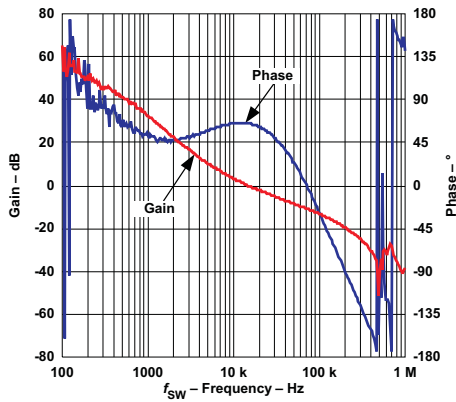


Figure 31. Gain and Phase vs Frequency

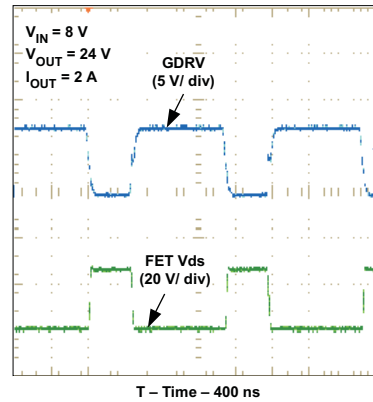


Figure 32. FET VDS and VGS Voltages vs Time

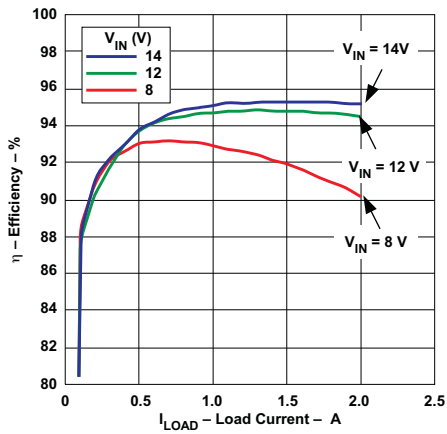


Figure 33. Efficiency vs Load Current

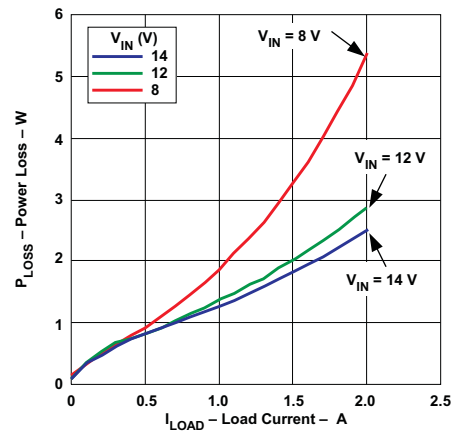


Figure 34. Power Loss vs Load Current

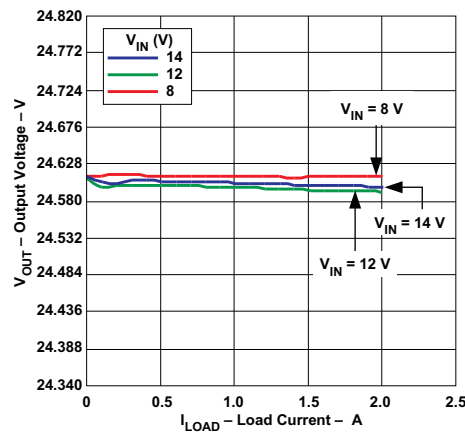
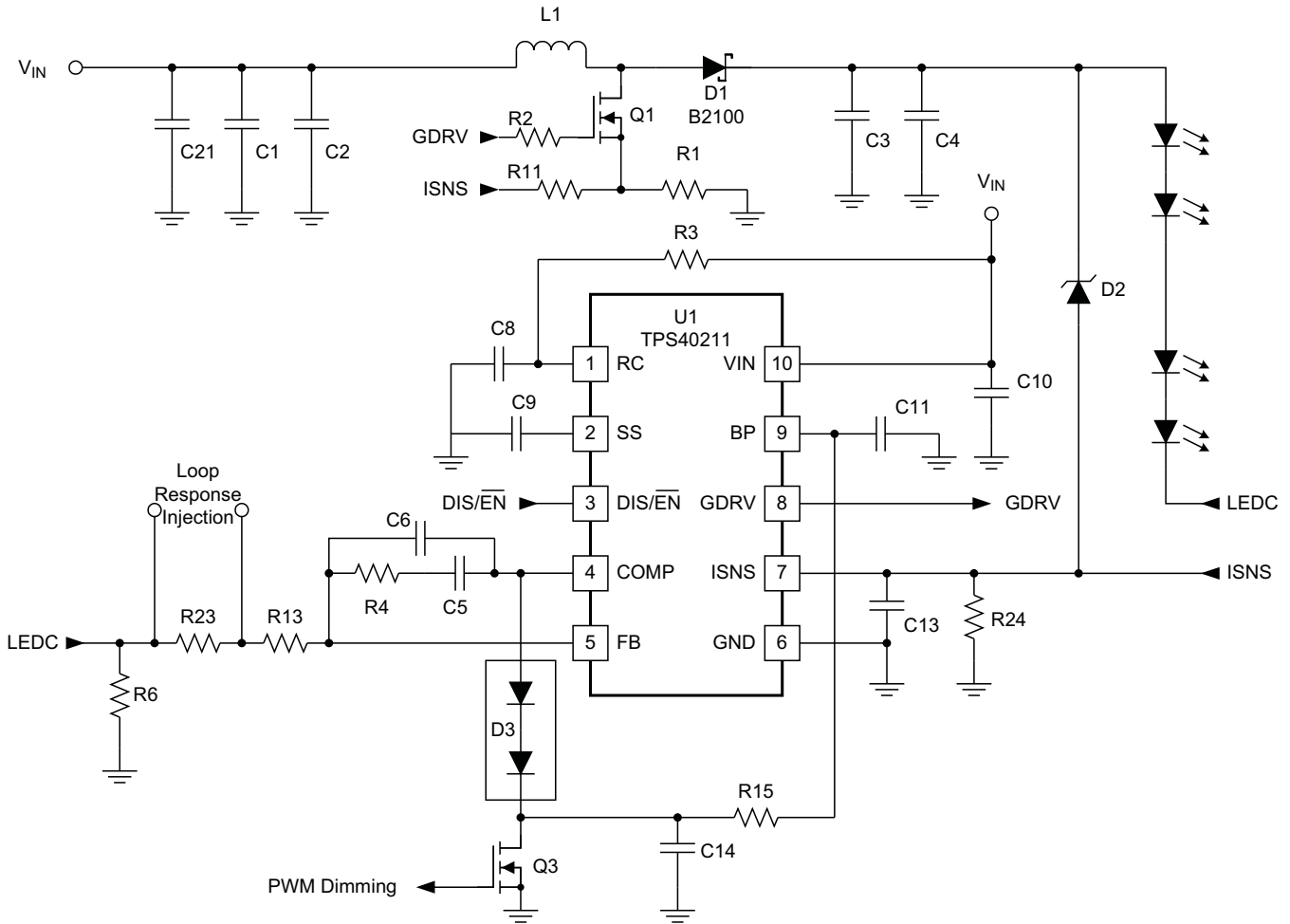


Figure 35. Output Voltage vs Load Current

### 8.2.2 12-V Input, 700-mA LED Driver, Up to 35-V LED String

This application uses the TPS40211 as a boost controller that drives a string of LED diodes. The feedback point for this circuit is a sense resistor in series with this string. The low 260 mV reference minimizes power wasted in this resistor, and maintains the LED current at a value given by  $0.26/R6$ . As the input voltage is varied, the duty cycle changes to maintain the LED current at a constant value so that the light intensity does not change with large input voltage variations.



UDG-08015

Figure 36. 12-V Input, 700-mA LED Driver, Up to 35-V LED String

#### 8.2.2.1 Design Requirements

Table 3. TPS40211 Design Example Specifications

PARAMETER		MIN	TYP	MAX	UNIT
<b>INPUT CHARACTERISTICS</b>					
$V_{IN}$	Input voltage	8	12	20	V
<b>OUTPUT CHARACTERISTICS</b>					
$V_{OUT}$	Output voltage			35	V
$I_{OUT}$	Output current		0.7		A
<b>SYSTEM CHARACTERISTICS</b>					
$f_{SW}$	Switching frequency		400		kHz

**8.2.2.2 Detailed Design Procedure**
**Table 4. TPS40211 LED Driver Bill of Materials**

REFERENCE DESIGNATOR	TYPE	DESCRIPTION	SIZE	
C1,C2	Capacitor	10 $\mu$ F, 25 V	1206	
C3, C4		2.2 $\mu$ F, 100 V	1210	
C5		1 nF, NPO	0603	
C6		100 pF, NPO	0603	
C8		100 pF	0603	
C9		0.1 $\mu$ F	0603	
C10		0.1 $\mu$ F, 25 V	0805	
C11		1 $\mu$ F, 25 V	1206	
C13		220 pF	0603	
C14		10 nF, X7R	0603	
C21		330 $\mu$ F, 25V electrolytic		
D1		Diode	B2100, SHTKY, 100 V, 2 A	SMB
D2			BZT52C43	SOD-123
D3			MMBD7000	SOT-23
L1	Inductor	Würth 7447709100, 10 $\mu$ H, 6 A	12mm x 12mm x 10mm	
Q1	MOSFET	Si7850DP, 60 V, 31 m $\Omega$	SO-8	
Q3		2N7002, 60 V, 0.1 A	SOT-23	
R1	Resistor	15 m $\Omega$	2512	
R2		3.01 $\Omega$	0805	
R3		402 k $\Omega$	0603	
R4		14.3 k $\Omega$	0603	
R6		0.36 $\Omega$	2512	
R11		1 k $\Omega$	0603	
R13		30.1 k $\Omega$	0603	
R15		49.9 k $\Omega$	0603	
R24		10 k $\Omega$	0603	
R23		10 $\Omega$	0603	
U1		Integrated circuit	TPS40211	DRC-10

## 9 Power Supply Recommendations

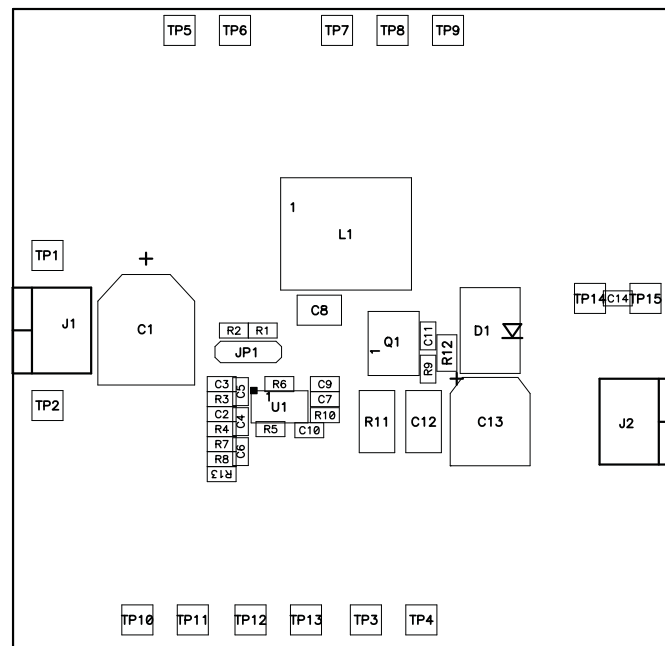
The TPS4021x is designed to operate from an input voltage supply range between 4.5 V and 52 V. This input supply should remain within the input voltage range of the TPS4021x. If the input supply is located more than a few inches from the buck power stage controlled by the TPS4021x, additional bulk capacitance may be required in addition to ceramic-bypass capacitors. An electrolytic capacitor with a value of 100  $\mu$ F is a typical choice.

## 10 Layout

### 10.1 Layout Guidelines

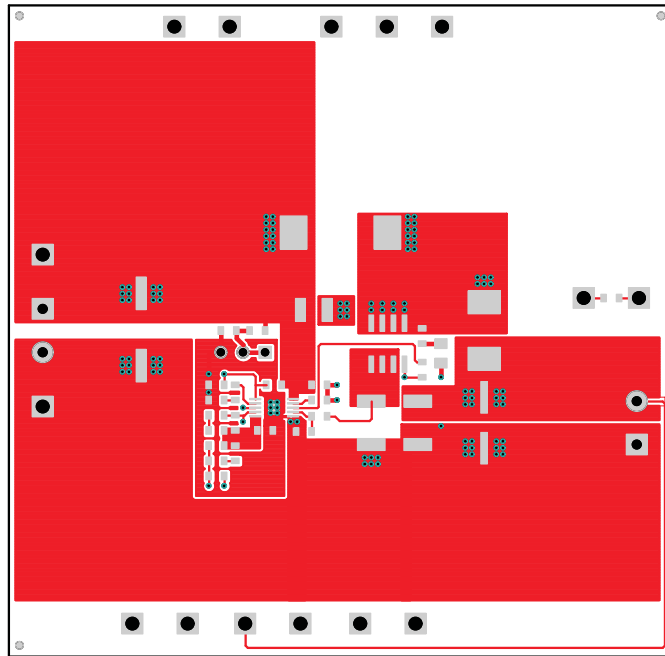
- For the maximum effectiveness from C9, place it near the VDD pin of the controller. Excessive high frequency noise on VDD during switching degrades overall regulation as the load increases.
- Keep the output loop (Q1-D1-C12-R11) as small as possible. A larger loop can degrade current limit accuracy and increase radiated emissions.
- For best current limit accuracy keep the ISNS filter components C10 and R10 near the ISNS and GND pins.
- Avoid connecting traces carrying large AC currents through a ground plane. Instead, use PCB traces on the top layer to conduct the AC current and use the ground plane as a noise shield.
- Split the ground plane as necessary to keep noise away from the TPS4021x and noise sensitive areas such as components connected to the RC pin, FB pin, COMP pin and SS pin. Also keep these noise sensitive components close to the TPS4021x IC.
- Keep C7 near the BP and GND pins to provide good bypass for the BP regulator.
- The GDRV trace should be as close as possible to the power FET gate to minimize parasitic resistance and inductance in the trace. The parasitics should also be minimized in the return path from the source of the MOSFET, through the sense resistor and back to the GND pin.
- Keep the SW node as physically small as possible to minimize parasitic capacitance and radiated emissions.
- For good output voltage regulation, Kelvin connections should be brought from the load to the top FB resistor R7.

### 10.2 Layout Example

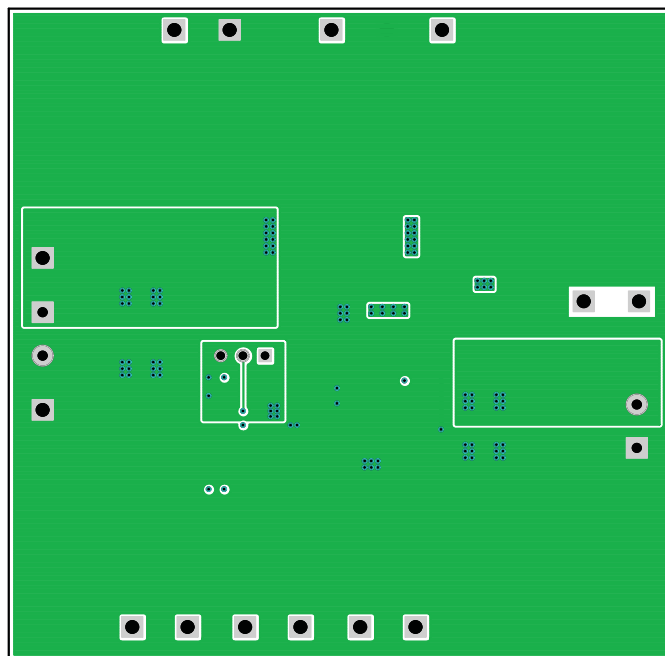


**Figure 37. Component Placement**

**Layout Example (continued)**

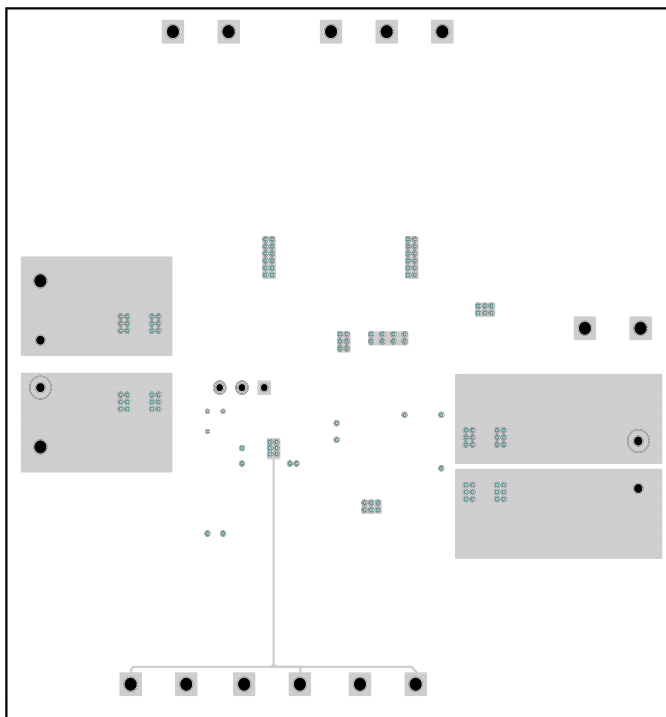


**Figure 38. Top Copper**

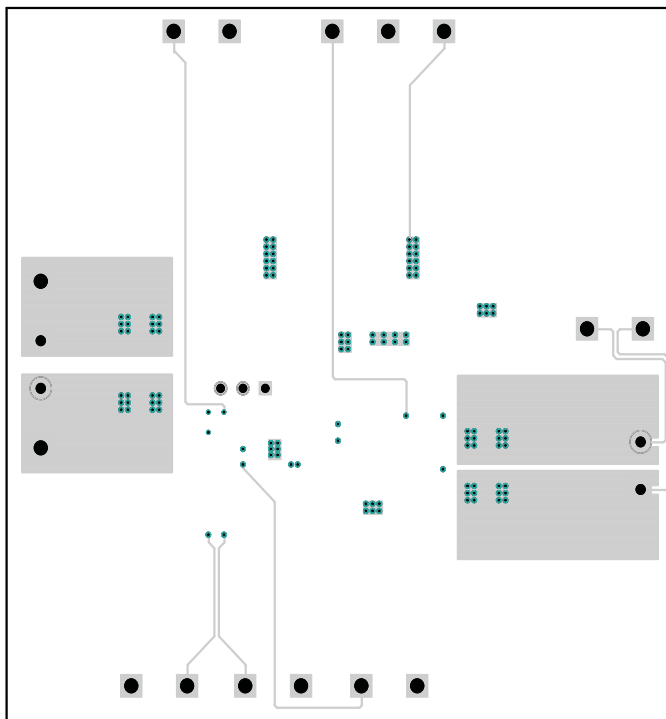


**Figure 39. Bottom Copper Viewed From Top**

**Layout Example (continued)**



**Figure 40. Internal 1 Copper Viewed From Top**



**Figure 41. Internal 2 Copper Viewed From Top**

## 11 Device and Documentation Support

### 11.1 Device Support

#### 11.1.1 Third-Party Products Disclaimer

TI'S PUBLICATION OF INFORMATION REGARDING THIRD-PARTY PRODUCTS OR SERVICES DOES NOT CONSTITUTE AN ENDORSEMENT REGARDING THE SUITABILITY OF SUCH PRODUCTS OR SERVICES OR A WARRANTY, REPRESENTATION OR ENDORSEMENT OF SUCH PRODUCTS OR SERVICES, EITHER ALONE OR IN COMBINATION WITH ANY TI PRODUCT OR SERVICE.

#### 11.1.2 Related Devices

The following devices have characteristics similar to the TPS40210 and may be of interest.

**Table 5. Related Parts**

DEVICE	DESCRIPTION
TPS6100x	Single- and Dual-Cell Boost Converter with Start-up into Full Load
TPS6101x	High Efficiency 1-Cell and 2-Cell Boost Converters
TPS6300x	High Efficiency Single Inductor Buck-Boost Converter with 1.8A Switches

### 11.2 Documentation Support

#### 11.2.1 Custom Design with WEBENCH Tools

[Click here](#) to create a custom design using the TPS40210 device with the WEBENCH<sup>®</sup> Power Designer.

1. Start by entering your  $V_{IN}$ ,  $V_{OUT}$  and  $I_{OUT}$  requirements.
2. Optimize your design for key parameters like efficiency, footprint and cost using the optimizer dial and compare this design with other possible solutions from Texas Instruments.
3. WEBENCH Power Designer provides you with a customized schematic along with a list of materials with real time pricing and component availability.
4. In most cases, you will also be able to:
  - Run electrical simulations to see important waveforms and circuit performance,
  - Run thermal simulations to understand the thermal performance of your board,
  - Export your customized schematic and layout into popular CAD formats,
  - Print PDF reports for the design, and share your design with colleagues.
5. Get more information about WEBENCH tools at [www.ti.com/webench](http://www.ti.com/webench).

#### 11.2.2 Receiving Notification of Documentation Updates

To receive notification of documentation updates, navigate to the device product folder on ti.com. In the upper right corner, click on *Alert me* to register and receive a weekly digest of any product information that has changed. For change details, review the revision history included in any revised document.

#### 11.2.3 References

These references may be found on the web at [www.power.ti.com](http://www.power.ti.com) under Technical Documents. Many design tools and links to additional references, may also be found at [www.power.ti.com](http://www.power.ti.com)

1. *Design and Application Guide for High Speed MOSFET Gate Drive Circuits*, SEM 1400, 2001 Seminar Series
2. *Designing Stable Control Loops*, SEM 1400, 2001 Seminar Series
3. Additional PowerPAD<sup>™</sup> information may be found in Applications Briefs [SLMA002](#) and [SLMA004](#)
4. QFN/SON PCB Attachment, [SLUA271](#), June 2002

### 11.3 Related Links

The table below lists quick access links. Categories include technical documents, support and community resources, tools and software, and quick access to sample or buy.

**Table 6. Related Links**

PARTS	PRODUCT FOLDER	SAMPLE & BUY	TECHNICAL DOCUMENTS	TOOLS & SOFTWARE	SUPPORT & COMMUNITY
TPS40210	<a href="#">Click here</a>	<a href="#">Click here</a>	<a href="#">Click here</a>	<a href="#">Click here</a>	<a href="#">Click here</a>
TPS40211	<a href="#">Click here</a>	<a href="#">Click here</a>	<a href="#">Click here</a>	<a href="#">Click here</a>	<a href="#">Click here</a>

### 11.4 Trademarks

PowerPAD is a trademark of Texas Instruments.

WEBENCH is a registered trademark of Texas Instruments.

All other trademarks are the property of their respective owners.

### 11.5 Electrostatic Discharge Caution



This integrated circuit can be damaged by ESD. Texas Instruments recommends that all integrated circuits be handled with appropriate precautions. Failure to observe proper handling and installation procedures can cause damage.

ESD damage can range from subtle performance degradation to complete device failure. Precision integrated circuits may be more susceptible to damage because very small parametric changes could cause the device not to meet its published specifications.

### 11.6 Glossary

[SLYZ022](#) — *TI Glossary*.

This glossary lists and explains terms, acronyms, and definitions.

## 12 Mechanical, Packaging, and Orderable Information

The following pages include mechanical, packaging, and orderable information. This information is the most current data available for the designated devices. This data is subject to change without notice and revision of this document. For browser-based versions of this data sheet, refer to the left-hand navigation.

**PACKAGING INFORMATION**

Orderable Device	Status (1)	Package Type	Package Drawing	Pins	Package Qty	Eco Plan (2)	Lead/Ball Finish (6)	MSL Peak Temp (3)	Op Temp (°C)	Device Marking (4/5)	Samples
TPS40210DGQ	ACTIVE	MSOP-PowerPAD	DGQ	10	80	Green (RoHS & no Sb/Br)	CU NIPDAU   CU NIPDAUAG	Level-1-260C-UNLIM	-40 to 125	40210	<a href="#">Samples</a>
TPS40210DGQG4	ACTIVE	MSOP-PowerPAD	DGQ	10	80	Green (RoHS & no Sb/Br)	CU NIPDAUAG	Level-1-260C-UNLIM	-40 to 125	40210	<a href="#">Samples</a>
TPS40210DGQR	ACTIVE	MSOP-PowerPAD	DGQ	10	2500	Green (RoHS & no Sb/Br)	CU NIPDAU   CU NIPDAUAG	Level-1-260C-UNLIM	-40 to 125	40210	<a href="#">Samples</a>
TPS40210DGQRG4	ACTIVE	MSOP-PowerPAD	DGQ	10	2500	Green (RoHS & no Sb/Br)	CU NIPDAUAG	Level-1-260C-UNLIM	-40 to 125	40210	<a href="#">Samples</a>
TPS40210DRCR	ACTIVE	VSON	DRC	10	3000	Green (RoHS & no Sb/Br)	CU NIPDAU	Level-2-260C-1 YEAR	-40 to 125	4210	<a href="#">Samples</a>
TPS40210DRCT	ACTIVE	VSON	DRC	10	250	Green (RoHS & no Sb/Br)	CU NIPDAU	Level-2-260C-1 YEAR	-40 to 125	4210	<a href="#">Samples</a>
TPS40211DGQ	ACTIVE	MSOP-PowerPAD	DGQ	10	80	Green (RoHS & no Sb/Br)	CU NIPDAU   CU NIPDAUAG	Level-1-260C-UNLIM	-40 to 125	40211	<a href="#">Samples</a>
TPS40211DGQR	ACTIVE	MSOP-PowerPAD	DGQ	10	2500	Green (RoHS & no Sb/Br)	CU NIPDAU   CU NIPDAUAG	Level-1-260C-UNLIM	-40 to 125	40211	<a href="#">Samples</a>
TPS40211DRCR	ACTIVE	VSON	DRC	10	3000	Green (RoHS & no Sb/Br)	CU NIPDAU	Level-2-260C-1 YEAR	-40 to 125	4211	<a href="#">Samples</a>
TPS40211DRCRG4	ACTIVE	VSON	DRC	10	3000	Green (RoHS & no Sb/Br)	CU NIPDAU	Level-2-260C-1 YEAR	-40 to 125	4211	<a href="#">Samples</a>
TPS40211DRCT	ACTIVE	VSON	DRC	10	250	Green (RoHS & no Sb/Br)	CU NIPDAU	Level-2-260C-1 YEAR	-40 to 125	4211	<a href="#">Samples</a>

(1) The marketing status values are defined as follows:

**ACTIVE:** Product device recommended for new designs.

**LIFEBUY:** TI has announced that the device will be discontinued, and a lifetime-buy period is in effect.

**NRND:** Not recommended for new designs. Device is in production to support existing customers, but TI does not recommend using this part in a new design.

**PREVIEW:** Device has been announced but is not in production. Samples may or may not be available.

**OBSOLETE:** TI has discontinued the production of the device.

(2) **RoHS:** TI defines "RoHS" to mean semiconductor products that are compliant with the current EU RoHS requirements for all 10 RoHS substances, including the requirement that RoHS substance do not exceed 0.1% by weight in homogeneous materials. Where designed to be soldered at high temperatures, "RoHS" products are suitable for use in specified lead-free processes. TI may reference these types of products as "Pb-Free".

**RoHS Exempt:** TI defines "RoHS Exempt" to mean products that contain lead but are compliant with EU RoHS pursuant to a specific EU RoHS exemption.

**Green:** TI defines "Green" to mean the content of Chlorine (Cl) and Bromine (Br) based flame retardants meet JS709B low halogen requirements of <=1000ppm threshold. Antimony trioxide based flame retardants must also meet the <=1000ppm threshold requirement.

- (3) MSL, Peak Temp. - The Moisture Sensitivity Level rating according to the JEDEC industry standard classifications, and peak solder temperature.
- (4) There may be additional marking, which relates to the logo, the lot trace code information, or the environmental category on the device.
- (5) Multiple Device Markings will be inside parentheses. Only one Device Marking contained in parentheses and separated by a "~" will appear on a device. If a line is indented then it is a continuation of the previous line and the two combined represent the entire Device Marking for that device.
- (6) Lead/Ball Finish - Orderable Devices may have multiple material finish options. Finish options are separated by a vertical ruled line. Lead/Ball Finish values may wrap to two lines if the finish value exceeds the maximum column width.

**Important Information and Disclaimer:**The information provided on this page represents TI's knowledge and belief as of the date that it is provided. TI bases its knowledge and belief on information provided by third parties, and makes no representation or warranty as to the accuracy of such information. Efforts are underway to better integrate information from third parties. TI has taken and continues to take reasonable steps to provide representative and accurate information but may not have conducted destructive testing or chemical analysis on incoming materials and chemicals. TI and TI suppliers consider certain information to be proprietary, and thus CAS numbers and other limited information may not be available for release.

In no event shall TI's liability arising out of such information exceed the total purchase price of the TI part(s) at issue in this document sold by TI to Customer on an annual basis.

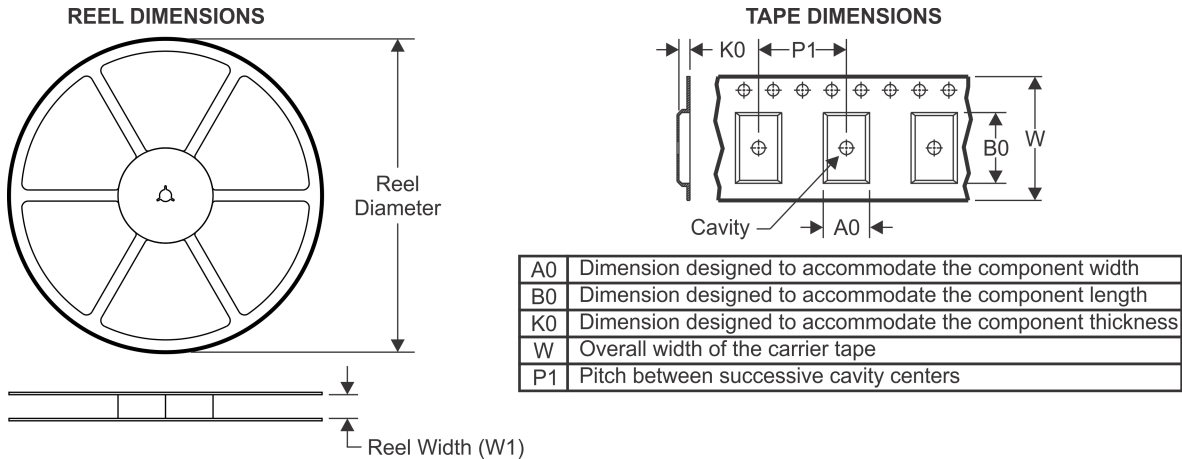
**OTHER QUALIFIED VERSIONS OF TPS40210, TPS40211 :**

- Automotive: [TPS40210-Q1](#), [TPS40211-Q1](#)
- Enhanced Product: [TPS40210-EP](#)

NOTE: Qualified Version Definitions:

- Automotive - Q100 devices qualified for high-reliability automotive applications targeting zero defects
- Enhanced Product - Supports Defense, Aerospace and Medical Applications

## TAPE AND REEL INFORMATION

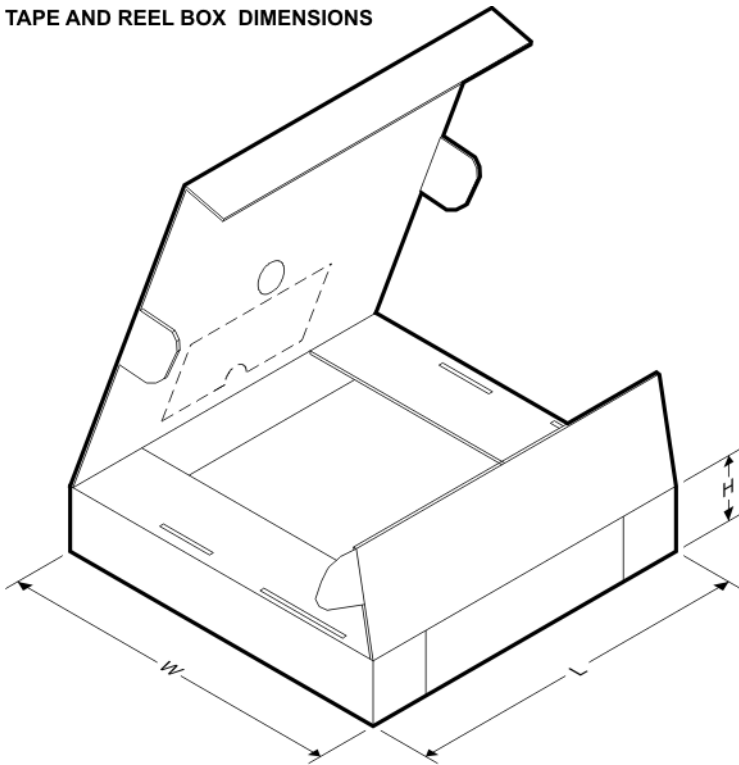


### QUADRANT ASSIGNMENTS FOR PIN 1 ORIENTATION IN TAPE



\*All dimensions are nominal

Device	Package Type	Package Drawing	Pins	SPQ	Reel Diameter (mm)	Reel Width W1 (mm)	A0 (mm)	B0 (mm)	K0 (mm)	P1 (mm)	W (mm)	Pin1 Quadrant
TPS40210DGQR	MSOP-Power PAD	DGQ	10	2500	330.0	12.4	5.3	3.3	1.3	8.0	12.0	Q1
TPS40210DGQR	MSOP-Power PAD	DGQ	10	2500	330.0	12.4	5.3	3.4	1.4	8.0	12.0	Q1
TPS40210DRCR	VSON	DRC	10	3000	330.0	12.4	3.3	3.3	1.1	8.0	12.0	Q2
TPS40210DRCT	VSON	DRC	10	250	180.0	12.4	3.3	3.3	1.1	8.0	12.0	Q2
TPS40211DGQR	MSOP-Power PAD	DGQ	10	2500	330.0	12.4	5.3	3.4	1.4	8.0	12.0	Q1
TPS40211DRCR	VSON	DRC	10	3000	330.0	12.4	3.3	3.3	1.1	8.0	12.0	Q2
TPS40211DRCT	VSON	DRC	10	250	180.0	12.4	3.3	3.3	1.1	8.0	12.0	Q2

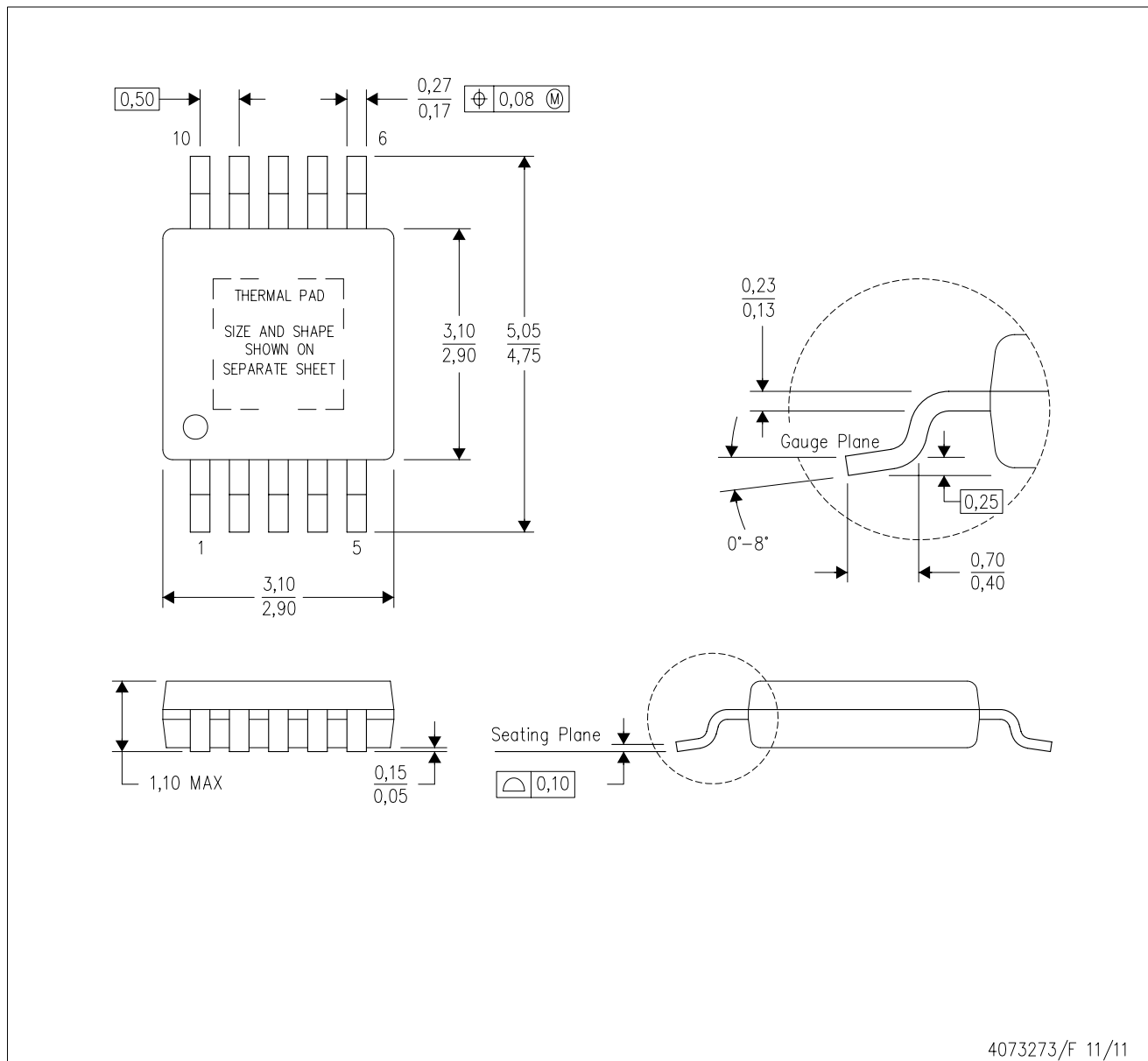
**TAPE AND REEL BOX DIMENSIONS**


\*All dimensions are nominal

Device	Package Type	Package Drawing	Pins	SPQ	Length (mm)	Width (mm)	Height (mm)
TPS40210DGQR	MSOP-PowerPAD	DGQ	10	2500	346.0	346.0	35.0
TPS40210DGQR	MSOP-PowerPAD	DGQ	10	2500	364.0	364.0	27.0
TPS40210DRCR	VSON	DRC	10	3000	367.0	367.0	35.0
TPS40210DRCT	VSON	DRC	10	250	210.0	185.0	35.0
TPS40211DGQR	MSOP-PowerPAD	DGQ	10	2500	364.0	364.0	27.0
TPS40211DRCR	VSON	DRC	10	3000	367.0	367.0	35.0
TPS40211DRCT	VSON	DRC	10	250	210.0	185.0	35.0

DGQ (S-PDSO-G10)

PowerPAD™ PLASTIC SMALL OUTLINE



4073273/F 11/11

- NOTES:
- A. All linear dimensions are in millimeters.
  - B. This drawing is subject to change without notice.
  - C. Body dimensions do not include mold flash or protrusion not to exceed 0,15.
  - D. This package is designed to be soldered to a thermal pad on the board. Refer to Technical Brief, PowerPad Thermally Enhanced Package, Texas Instruments Literature No. SLMA002 for information regarding recommended board layout. This document is available at [www.ti.com](http://www.ti.com) <<http://www.ti.com>>.
  - E. See the additional figure in the Product Data Sheet for details regarding the exposed thermal pad features and dimensions.
  - F. Falls within JEDEC MO-187 variation BA-T.

PowerPAD is a trademark of Texas Instruments.

DGQ (S-PDSO-G10)

PowerPAD™ PLASTIC SMALL OUTLINE

## THERMAL INFORMATION

This PowerPAD™ package incorporates an exposed thermal pad that is designed to be attached to a printed circuit board (PCB). The thermal pad must be soldered directly to the PCB. After soldering, the PCB can be used as a heatsink. In addition, through the use of thermal vias, the thermal pad can be attached directly to the appropriate copper plane shown in the electrical schematic for the device, or alternatively, can be attached to a special heatsink structure designed into the PCB. This design optimizes the heat transfer from the integrated circuit (IC).

For additional information on the PowerPAD package and how to take advantage of its heat dissipating abilities, refer to Technical Brief, PowerPAD Thermally Enhanced Package, Texas Instruments Literature No. SLMA002 and Application Brief, PowerPAD Made Easy, Texas Instruments Literature No. SLMA004. Both documents are available at [www.ti.com](http://www.ti.com).

The exposed thermal pad dimensions for this package are shown in the following illustration.



Top View

Exposed Thermal Pad Dimensions

4206324-2/H 12/14

NOTE: A. All linear dimensions are in millimeters

PowerPAD is a trademark of Texas Instruments



- NOTES:
- A. All linear dimensions are in millimeters.
  - B. This drawing is subject to change without notice.
  - C. Customers should place a note on the circuit board fabrication drawing not to alter the center solder mask defined pad.
  - D. This package is designed to be soldered to a thermal pad on the board. Refer to Technical Brief, PowerPad Thermally Enhanced Package, Texas Instruments Literature No. SLMA002, SLMA004, and also the Product Data Sheets for specific thermal information, via requirements, and recommended board layout. These documents are available at [www.ti.com](http://www.ti.com) <<http://www.ti.com>>. Publication IPC-7351 is recommended for alternate designs.
  - E. Laser cutting apertures with trapezoidal walls and also rounding corners will offer better paste release. Customers should contact their board assembly site for stencil design recommendations. Example stencil design based on a 50% volumetric metal load solder paste. Refer to IPC-7525 for other stencil recommendations.
  - F. Customers should contact their board fabrication site for solder mask tolerances between and around signal pads.

PowerPAD is a trademark of Texas Instruments

DGQ (S-PDSO-G10)

PowerPAD™ PLASTIC SMALL OUTLINE

## THERMAL INFORMATION

This PowerPAD™ package incorporates an exposed thermal pad that is designed to be attached to a printed circuit board (PCB). The thermal pad must be soldered directly to the PCB. After soldering, the PCB can be used as a heatsink. In addition, through the use of thermal vias, the thermal pad can be attached directly to the appropriate copper plane shown in the electrical schematic for the device, or alternatively, can be attached to a special heatsink structure designed into the PCB. This design optimizes the heat transfer from the integrated circuit (IC).

For additional information on the PowerPAD package and how to take advantage of its heat dissipating abilities, refer to Technical Brief, PowerPAD Thermally Enhanced Package, Texas Instruments Literature No. SLMA002 and Application Brief, PowerPAD Made Easy, Texas Instruments Literature No. SLMA004. Both documents are available at [www.ti.com](http://www.ti.com).

The exposed thermal pad dimensions for this package are shown in the following illustration.



Top View

Exposed Thermal Pad Dimensions

4206324-7/H 12/14

NOTE: A. All linear dimensions are in millimeters

PowerPAD is a trademark of Texas Instruments



- NOTES:
- A. All linear dimensions are in millimeters.
  - B. This drawing is subject to change without notice.
  - C. Customers should place a note on the circuit board fabrication drawing not to alter the center solder mask defined pad.
  - D. This package is designed to be soldered to a thermal pad on the board. Refer to Technical Brief, PowerPAD Thermally Enhanced Package, Texas Instruments Literature No. SLMA002, SLMA004, and also the Product Data Sheets for specific thermal information, via requirements, and recommended board layout. These documents are available at [www.ti.com](http://www.ti.com) <<http://www.ti.com>>. Publication IPC-7351 is recommended for alternate designs.
  - E. Laser cutting apertures with trapezoidal walls and also rounding corners will offer better paste release. Customers should contact their board assembly site for stencil design recommendations. Example stencil design based on a 50% volumetric metal load solder paste. Refer to IPC-7525 for other stencil recommendations.
  - F. Customers should contact their board fabrication site for solder mask tolerances between and around signal pads.

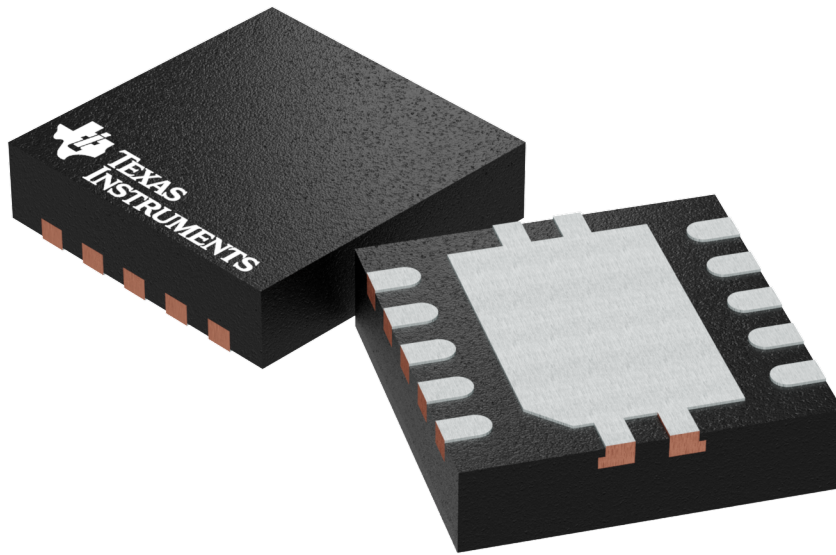
PowerPAD is a trademark of Texas Instruments

## GENERIC PACKAGE VIEW

DRC 10

VSON - 1 mm max height

PLASTIC SMALL OUTLINE - NO LEAD



Images above are just a representation of the package family, actual package may vary.  
Refer to the product data sheet for package details.

4204102-3/M

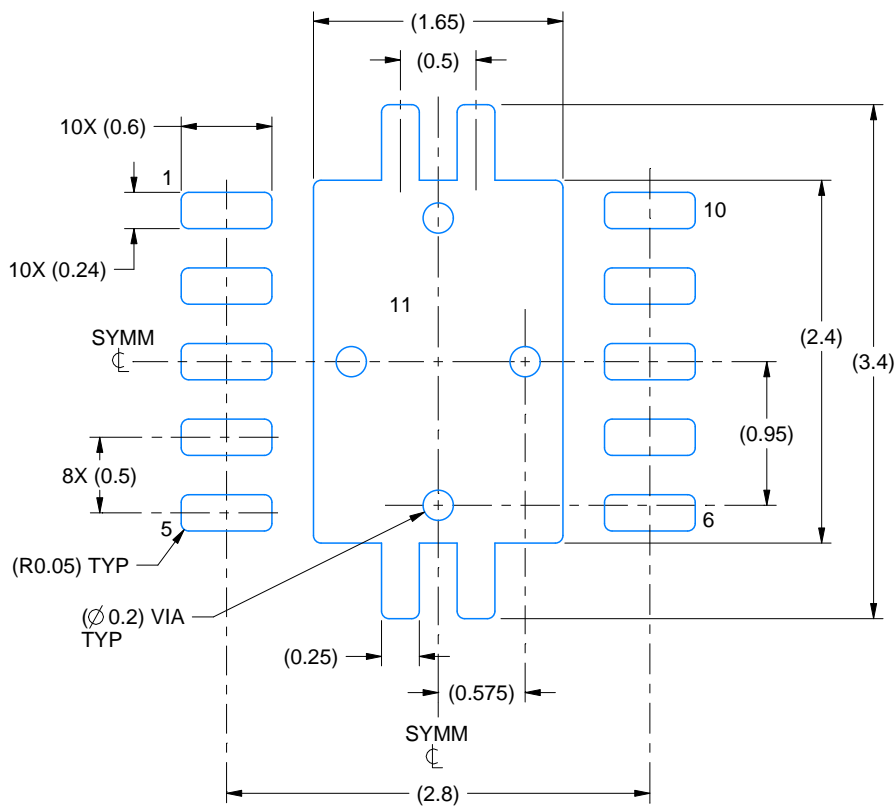


# EXAMPLE BOARD LAYOUT

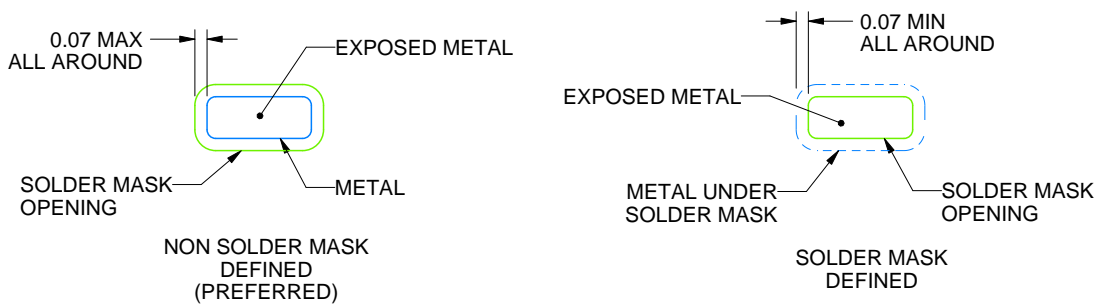
DRC0010J

VSON - 1 mm max height

PLASTIC SMALL OUTLINE - NO LEAD



LAND PATTERN EXAMPLE  
EXPOSED METAL SHOWN  
SCALE:20X



SOLDER MASK DETAILS

4218878/B 07/2018

NOTES: (continued)

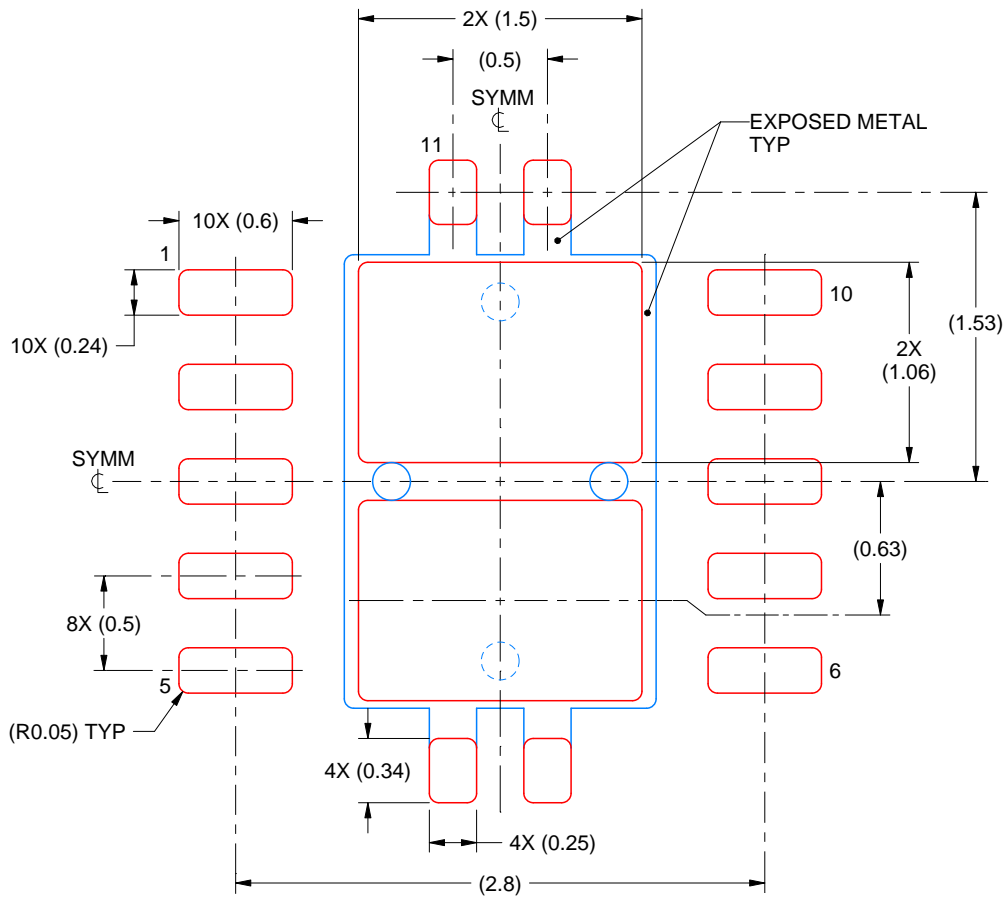
4. This package is designed to be soldered to a thermal pad on the board. For more information, see Texas Instruments literature number SLUA271 ([www.ti.com/lit/sluea271](http://www.ti.com/lit/sluea271)).
5. Vias are optional depending on application, refer to device data sheet. If any vias are implemented, refer to their locations shown on this view. It is recommended that vias under paste be filled, plugged or tented.

# EXAMPLE STENCIL DESIGN

DRC0010J

VSON - 1 mm max height

PLASTIC SMALL OUTLINE - NO LEAD



SOLDER PASTE EXAMPLE  
BASED ON 0.125 mm THICK STENCIL

EXPOSED PAD 11:  
80% PRINTED SOLDER COVERAGE BY AREA  
SCALE:25X

4218878/B 07/2018

NOTES: (continued)

6. Laser cutting apertures with trapezoidal walls and rounded corners may offer better paste release. IPC-7525 may have alternate design recommendations.

## IMPORTANT NOTICE

Texas Instruments Incorporated (TI) reserves the right to make corrections, enhancements, improvements and other changes to its semiconductor products and services per JESD46, latest issue, and to discontinue any product or service per JESD48, latest issue. Buyers should obtain the latest relevant information before placing orders and should verify that such information is current and complete.

TI's published terms of sale for semiconductor products (<http://www.ti.com/sc/docs/stdterms.htm>) apply to the sale of packaged integrated circuit products that TI has qualified and released to market. Additional terms may apply to the use or sale of other types of TI products and services.

Reproduction of significant portions of TI information in TI data sheets is permissible only if reproduction is without alteration and is accompanied by all associated warranties, conditions, limitations, and notices. TI is not responsible or liable for such reproduced documentation. Information of third parties may be subject to additional restrictions. Resale of TI products or services with statements different from or beyond the parameters stated by TI for that product or service voids all express and any implied warranties for the associated TI product or service and is an unfair and deceptive business practice. TI is not responsible or liable for any such statements.

Buyers and others who are developing systems that incorporate TI products (collectively, "Designers") understand and agree that Designers remain responsible for using their independent analysis, evaluation and judgment in designing their applications and that Designers have full and exclusive responsibility to assure the safety of Designers' applications and compliance of their applications (and of all TI products used in or for Designers' applications) with all applicable regulations, laws and other applicable requirements. Designer represents that, with respect to their applications, Designer has all the necessary expertise to create and implement safeguards that (1) anticipate dangerous consequences of failures, (2) monitor failures and their consequences, and (3) lessen the likelihood of failures that might cause harm and take appropriate actions. Designer agrees that prior to using or distributing any applications that include TI products, Designer will thoroughly test such applications and the functionality of such TI products as used in such applications.

TI's provision of technical, application or other design advice, quality characterization, reliability data or other services or information, including, but not limited to, reference designs and materials relating to evaluation modules, (collectively, "TI Resources") are intended to assist designers who are developing applications that incorporate TI products; by downloading, accessing or using TI Resources in any way, Designer (individually or, if Designer is acting on behalf of a company, Designer's company) agrees to use any particular TI Resource solely for this purpose and subject to the terms of this Notice.

TI's provision of TI Resources does not expand or otherwise alter TI's applicable published warranties or warranty disclaimers for TI products, and no additional obligations or liabilities arise from TI providing such TI Resources. TI reserves the right to make corrections, enhancements, improvements and other changes to its TI Resources. TI has not conducted any testing other than that specifically described in the published documentation for a particular TI Resource.

Designer is authorized to use, copy and modify any individual TI Resource only in connection with the development of applications that include the TI product(s) identified in such TI Resource. NO OTHER LICENSE, EXPRESS OR IMPLIED, BY ESTOPPEL OR OTHERWISE TO ANY OTHER TI INTELLECTUAL PROPERTY RIGHT, AND NO LICENSE TO ANY TECHNOLOGY OR INTELLECTUAL PROPERTY RIGHT OF TI OR ANY THIRD PARTY IS GRANTED HEREIN, including but not limited to any patent right, copyright, mask work right, or other intellectual property right relating to any combination, machine, or process in which TI products or services are used. Information regarding or referencing third-party products or services does not constitute a license to use such products or services, or a warranty or endorsement thereof. Use of TI Resources may require a license from a third party under the patents or other intellectual property of the third party, or a license from TI under the patents or other intellectual property of TI.

TI RESOURCES ARE PROVIDED "AS IS" AND WITH ALL FAULTS. TI DISCLAIMS ALL OTHER WARRANTIES OR REPRESENTATIONS, EXPRESS OR IMPLIED, REGARDING RESOURCES OR USE THEREOF, INCLUDING BUT NOT LIMITED TO ACCURACY OR COMPLETENESS, TITLE, ANY EPIDEMIC FAILURE WARRANTY AND ANY IMPLIED WARRANTIES OF MERCHANTABILITY, FITNESS FOR A PARTICULAR PURPOSE, AND NON-INFRINGEMENT OF ANY THIRD PARTY INTELLECTUAL PROPERTY RIGHTS. TI SHALL NOT BE LIABLE FOR AND SHALL NOT DEFEND OR INDEMNIFY DESIGNER AGAINST ANY CLAIM, INCLUDING BUT NOT LIMITED TO ANY INFRINGEMENT CLAIM THAT RELATES TO OR IS BASED ON ANY COMBINATION OF PRODUCTS EVEN IF DESCRIBED IN TI RESOURCES OR OTHERWISE. IN NO EVENT SHALL TI BE LIABLE FOR ANY ACTUAL, DIRECT, SPECIAL, COLLATERAL, INDIRECT, PUNITIVE, INCIDENTAL, CONSEQUENTIAL OR EXEMPLARY DAMAGES IN CONNECTION WITH OR ARISING OUT OF TI RESOURCES OR USE THEREOF, AND REGARDLESS OF WHETHER TI HAS BEEN ADVISED OF THE POSSIBILITY OF SUCH DAMAGES.

Unless TI has explicitly designated an individual product as meeting the requirements of a particular industry standard (e.g., ISO/TS 16949 and ISO 26262), TI is not responsible for any failure to meet such industry standard requirements.

Where TI specifically promotes products as facilitating functional safety or as compliant with industry functional safety standards, such products are intended to help enable customers to design and create their own applications that meet applicable functional safety standards and requirements. Using products in an application does not by itself establish any safety features in the application. Designers must ensure compliance with safety-related requirements and standards applicable to their applications. Designer may not use any TI products in life-critical medical equipment unless authorized officers of the parties have executed a special contract specifically governing such use. Life-critical medical equipment is medical equipment where failure of such equipment would cause serious bodily injury or death (e.g., life support, pacemakers, defibrillators, heart pumps, neurostimulators, and implantables). Such equipment includes, without limitation, all medical devices identified by the U.S. Food and Drug Administration as Class III devices and equivalent classifications outside the U.S.

TI may expressly designate certain products as completing a particular qualification (e.g., Q100, Military Grade, or Enhanced Product). Designers agree that it has the necessary expertise to select the product with the appropriate qualification designation for their applications and that proper product selection is at Designers' own risk. Designers are solely responsible for compliance with all legal and regulatory requirements in connection with such selection.

Designer will fully indemnify TI and its representatives against any damages, costs, losses, and/or liabilities arising out of Designer's non-compliance with the terms and provisions of this Notice.

## Looking for pricing, stock, or lifecycle information?

Click below to explore more details on WIN SOURCE:

 [View TPS40211DGQRG4 on WIN SOURCE](#)

 [Texas Instruments](#) Information

## Optimize Your Supply Chain with WIN SOURCE Solutions

-  Global Sourcing Solution
-  Obsolete Management
-  Cost Control Management
-  Shortage Management
-  Alternative Solution
-  Excess Inventory Management