

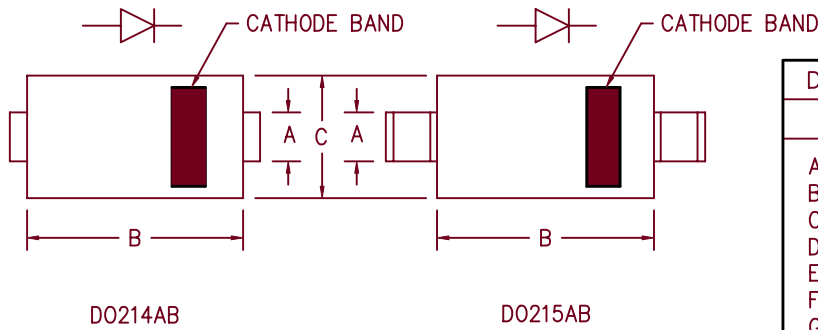

**THE DATASHEET OF  
LSM340JE3/TR13**



# 3 Amp Schottky Rectifier LSM335 — LSM345



Dim.	Inches		Millimeter		Notes
	Minimum	Maximum	Minimum	Maximum	
A	.117	.123	2.97	3.12	
B	.260	.280	6.60	7.11	
C	.220	.245	5.59	6.22	
D	.307	.322	7.80	8.18	
E	.075	.095	1.91	2.41	
F	.380	.400	9.65	10.16	
G	.025	.040	.640	1.02	
H	.030	.060	.760	1.52	

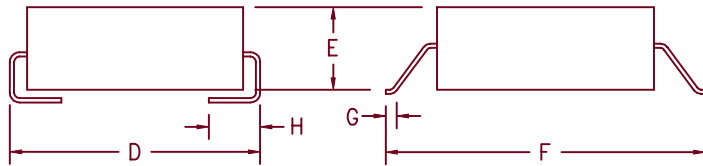

Microsemi Catalog Number	Industry Part Number	Working Peak Reverse Voltage	Repetitive Peak Reverse Voltage
LSM335*		35V	35V
LSM340*	30BQ040 15MQ040N MBRS340TR	40V	40V
LSM345*		45V	45V

\* Add Suffix J for J Lead or G for Gull Wing Lead Configuration

- Schottky Barrier Rectifier
- Guard ring protection
- Low forward voltage
- 150°C Junction temperature
- Reverse energy tested

Electrical Characteristics		
Average forward current	I <sub>F(AV)</sub> 3.0 Amps	Square wave
Maximum surge current	I <sub>FSM</sub> 150 Amps	8.3ms, half sine, T <sub>J</sub> = 150°C
Max peak forward voltage	V <sub>FM</sub> .45 Volts	I <sub>FM</sub> = 1.0A; T <sub>J</sub> = 25°C *
Max peak forward voltage	V <sub>FM</sub> .52 Volts	I <sub>FM</sub> = 3.0A; T <sub>J</sub> = 25°C *
Max peak forward voltage	V <sub>FM</sub> .76 Volts	I <sub>FM</sub> = 9.4A; T <sub>J</sub> = 25°C *
Max peak reverse current	I <sub>RM</sub> 1.5 mA	V <sub>R</sub> = 5.0V, T <sub>J</sub> = 25°C
Typical junction capacitance	C <sub>J</sub> 265 pF	

\*Pulse test: Pulse width 300 μsec, Duty cycle 2%

Thermal and Mechanical Characteristics		
Storage temperature range	T <sub>STG</sub>	-55°C to 175°C
Operating junction temp range	T <sub>J</sub>	-55°C to 150°C
Maximum thermal resistance	R <sub>ΘJL</sub>	25°C/W Junction to lead
Weight		.008 ounces (.22 grams) typical

11-21-01 Rev. 2

# LSM335 — LSM345

Figure 1  
Typical Forward Characteristics

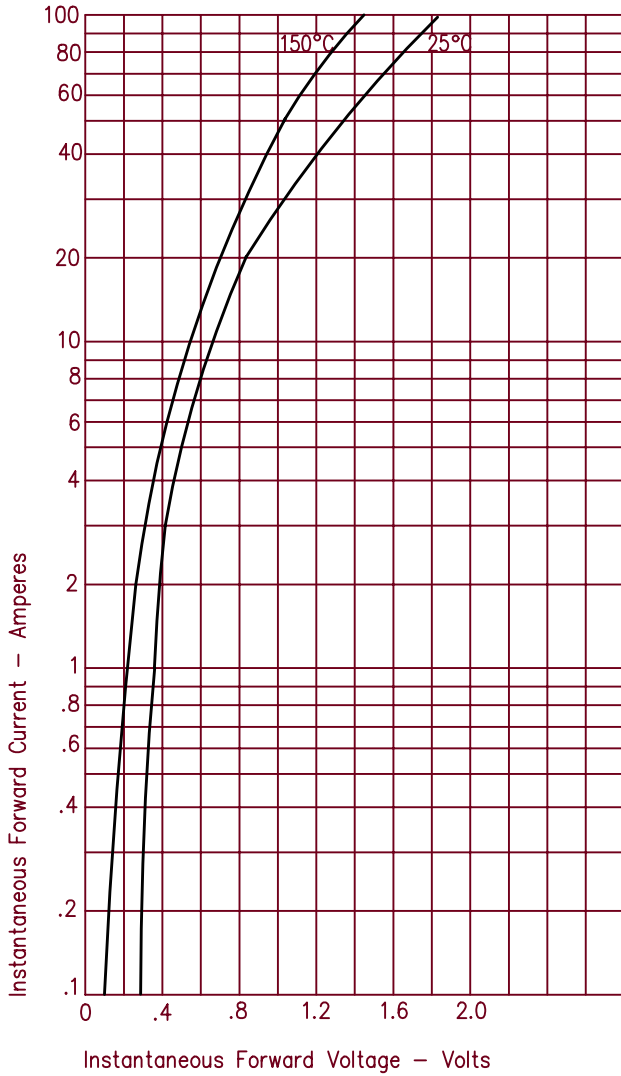

Figure 3  
Typical Junction Capacitance

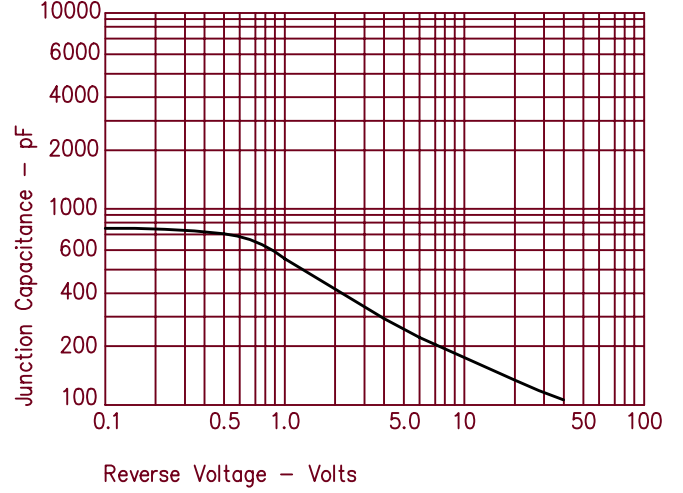
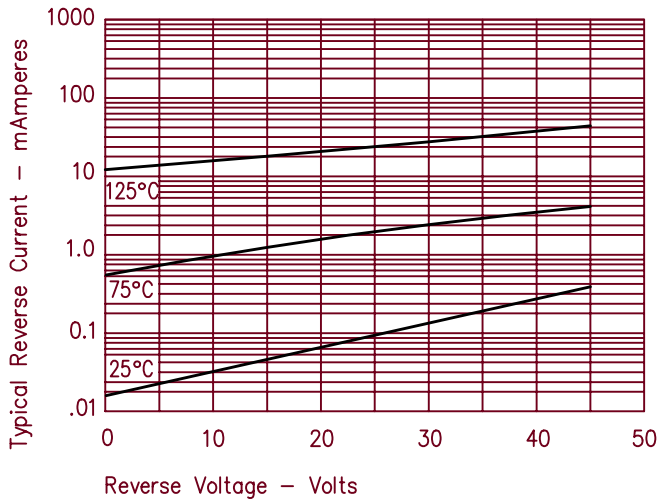

Figure 2  
Typical Reverse Characteristics



## Looking for pricing, stock, or lifecycle information?

Click below to explore more details on WIN SOURCE:

- ⊖ [View LSM340JE3/TR13 on WIN SOURCE](#)
- ⊖ [Microsemi Corporation](#) Information

## Optimize Your Supply Chain with WIN SOURCE Solutions

- ✓ Global Sourcing Solution
- ✓ Obsolete Management
- ✓ Cost Control Management
- ✓ Shortage Management
- ✓ Alternative Solution
- ✓ Excess Inventory Management