



**THE DATASHEET OF
SN74HC191N**



SN54HC191, SN74HC191 4-BIT SYNCHRONOUS UP/DOWN BINARY COUNTERS

SCLS121D – DECEMBER 1982 – REVISED OCTOBER 2003

- Wide Operating Voltage Range of 2 V to 6 V
- Outputs Can Drive Up To 10 LSTTL Loads
- Low Power Consumption, 80- μ A Max I_{CC}
- Typical $t_{pd} = 13$ ns
- ± 4 -mA Output Drive at 5 V
- Low Input Current of 1 μ A Max
- Single Down/Up Count-Control Line
- Look-Ahead Circuitry Enhances Speed of Cascaded Counters
- Fully Synchronous in Count Modes
- Asynchronously Presetable With Load Control

SN54HC191 . . . J OR W PACKAGE
SN74HC191 . . . D, N, OR NS PACKAGE
(TOP VIEW)

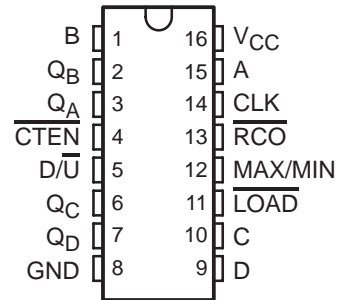

SN54HC191 . . . FK PACKAGE
(TOP VIEW)

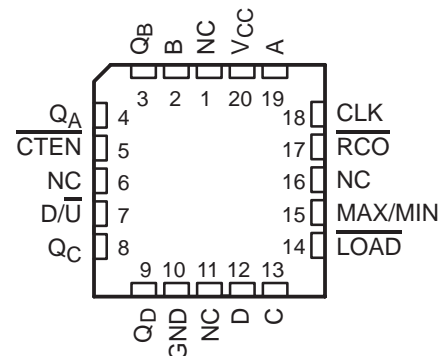

NC – No internal connection

description/ordering information

The 'HC191 devices are 4-bit synchronous, reversible, up/down binary counters. Synchronous counting operation is provided by having all flip-flops clocked simultaneously so that the outputs change coincident with each other when instructed by the steering logic. This mode of operation eliminates the output counting spikes normally associated with asynchronous (ripple-clock) counters.

The outputs of the four flip-flops are triggered on a low- to high-level transition of the clock (CLK) input if the count-enable (\overline{CTEN}) input is low. A high at \overline{CTEN} inhibits counting. The direction of the count is determined by the level of the down/up (D/U) input. When D/U is low, the counter counts up, and when D/U is high, it counts down.

ORDERING INFORMATION

TA	PACKAGE†		ORDERABLE PART NUMBER	TOP-SIDE MARKING
-40°C to 85°C	PDIP – N	Tube of 25	SN74HC191N	SN74HC191N
	SOIC – D	Tube of 40	SN74HC191D	HC191
		Reel of 2500	SN74HC191DR	
		Reel of 250	SN74HC191DT	
SOP – NS	Reel of 2000	SN74HC191NSR	HC191	
-55°C to 125°C	CDIP – J	Tube of 25	SNJ54HC191J	SNJ54HC191J
	CFP – W	Tube of 150	SNJ54HC191W	SNJ54HC191W
	LCCC – FK	Tube of 55	SNJ54HC191FK	SNJ54HC191FK

† Package drawings, standard packing quantities, thermal data, symbolization, and PCB design guidelines are available at www.ti.com/sc/package.



Please be aware that an important notice concerning availability, standard warranty, and use in critical applications of Texas Instruments semiconductor products and disclaimers thereto appears at the end of this data sheet.

PRODUCTION DATA information is current as of publication date. Products conform to specifications per the terms of Texas Instruments standard warranty. Production processing does not necessarily include testing of all parameters.

 **TEXAS
INSTRUMENTS**

POST OFFICE BOX 655303 • DALLAS, TEXAS 75265

Copyright © 2003, Texas Instruments Incorporated
On products compliant to MIL-PRF-38535, all parameters are tested unless otherwise noted. On all other products, production processing does not necessarily include testing of all parameters.

SN54HC191, SN74HC191

4-BIT SYNCHRONOUS UP/DOWN BINARY COUNTERS

SCLS121D – DECEMBER 1982 – REVISED OCTOBER 2003

description/ordering information (continued)

These counters feature a fully independent clock circuit. Change at the control (\overline{CTEN} and D/\overline{U}) inputs that modifies the operating mode have no effect on the contents of the counter until clocking occurs. The function of the counter is dictated solely by the condition meeting the stable setup and hold times.

These counters are fully programmable; that is, each of the outputs can be preset to either level by placing a low on the load (\overline{LOAD}) input and entering the desired data at the data inputs. The output changes to agree with the data inputs independently of the level of CLK. This feature allows the counters to be used as modulo-N dividers simply by modifying the count length with the preset inputs.

Two outputs are available to perform the cascading function: ripple clock (\overline{RCO}) and maximum/minimum (MAX/MIN) count. MAX/MIN produces a high-level output pulse with a duration approximately equal to one complete cycle of the clock while the count is zero (all outputs low) counting down, or maximum (9 or 15) counting up. \overline{RCO} produces a low-level output pulse under those same conditions, but only while CLK is low. The counters can be cascaded easily by feeding \overline{RCO} to \overline{CTEN} of the succeeding counter if parallel clocking is used, or to CLK if parallel enabling is used. MAX/MIN can be used to accomplish look ahead for high-speed operation.



POST OFFICE BOX 655303 • DALLAS, TEXAS 75265

SN54HC191, SN74HC191 4-BIT SYNCHRONOUS UP/DOWN BINARY COUNTERS

SCLS121D – DECEMBER 1982 – REVISED OCTOBER 2003

logic diagram (positive logic)

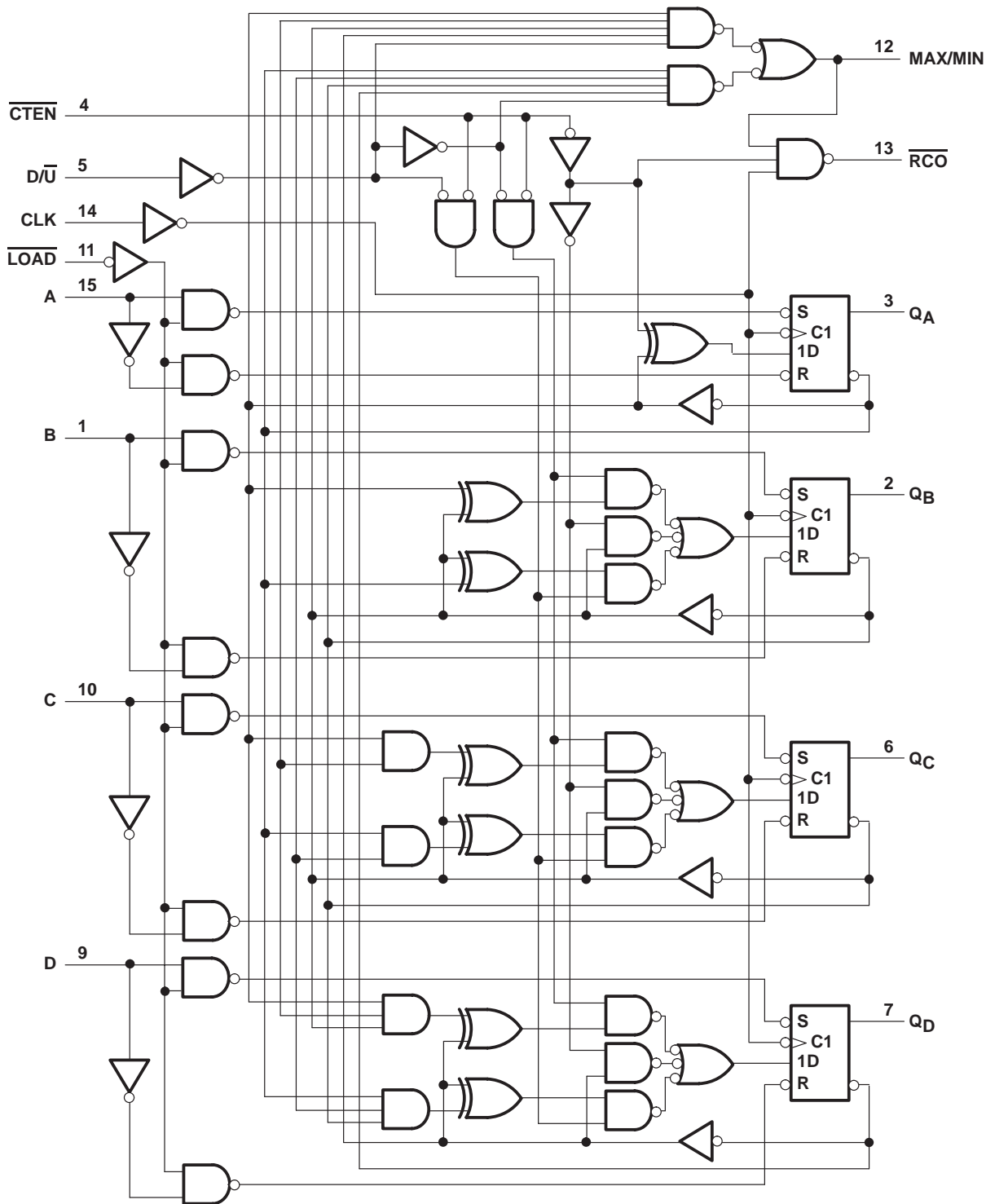

Pin numbers shown are for the D, J, N, NS, and W packages.

SN54HC191, SN74HC191 4-BIT SYNCHRONOUS UP/DOWN BINARY COUNTERS

SCLS121D – DECEMBER 1982 – REVISED OCTOBER 2003

typical load, count, and inhibit sequence

The following sequence is illustrated below:

1. Load (preset) to binary 13
2. Count up to 14, 15 (maximum), 0, 1, and 2
3. Inhibit
4. Count down to 1, 0 (minimum), 15, 14, and 13

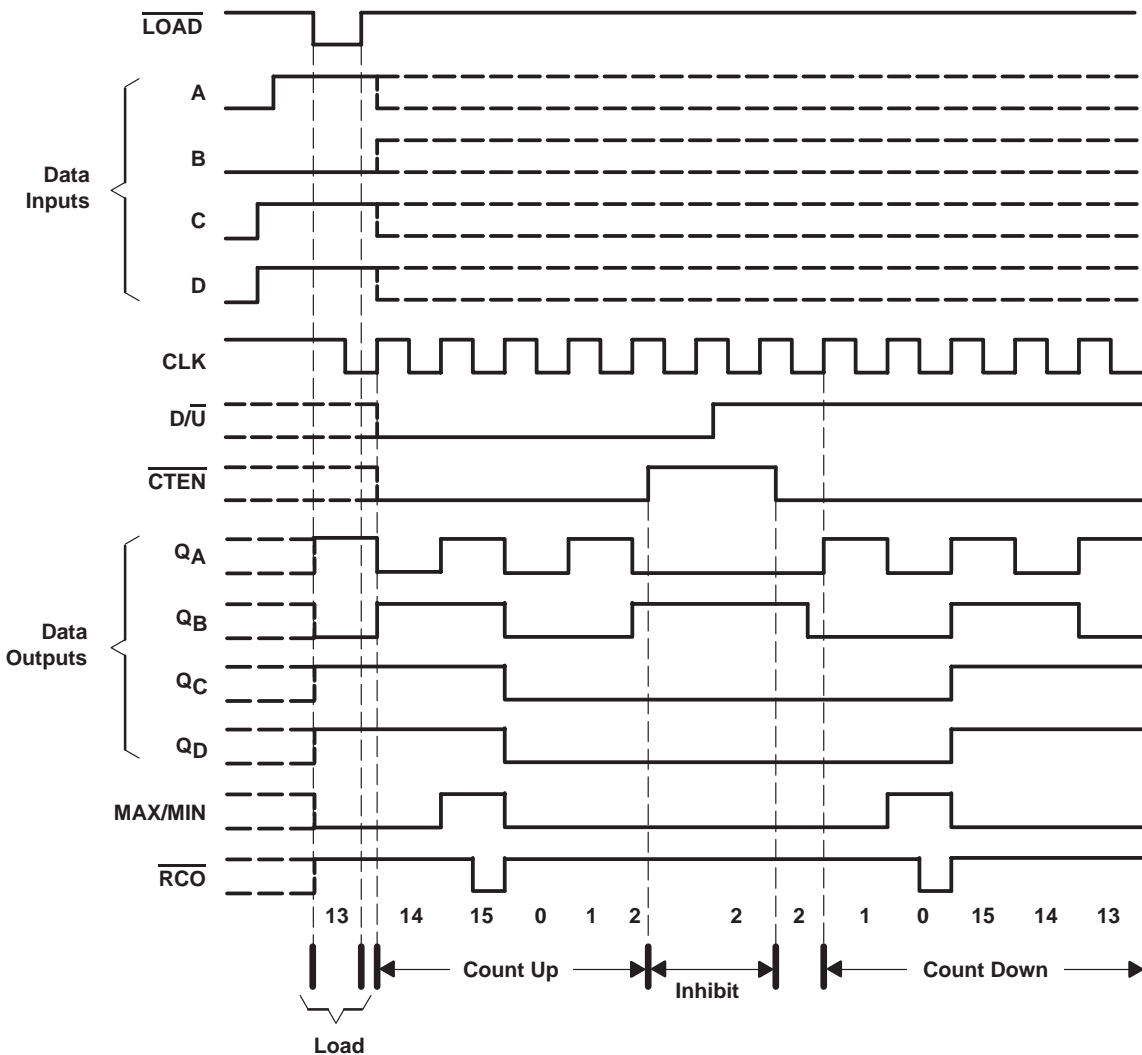

SN54HC191, SN74HC191

4-BIT SYNCHRONOUS UP/DOWN BINARY COUNTERS

SCLS121D – DECEMBER 1982 – REVISED OCTOBER 2003

absolute maximum ratings over operating free-air temperature range (unless otherwise noted)†

Supply voltage range, V_{CC}	–0.5 V to 7 V
Input clamp current, I_{IK} ($V_I < 0$ or $V_I > V_{CC}$) (see Note 1)	±20 mA
Output clamp current, I_{OK} ($V_O < 0$ or $V_O > V_{CC}$) (see Note 1)	±20 mA
Continuous output current, I_O ($V_O = 0$ to V_{CC})	±25 mA
Continuous current through V_{CC} or GND	±50 mA
Package thermal impedance, θ_{JA} (see Note 2): D package	73°C/W
N package	67°C/W
NS package	64°C/W
Storage temperature range, T_{stg}	–65°C to 150°C

† Stresses beyond those listed under “absolute maximum ratings” may cause permanent damage to the device. These are stress ratings only, and functional operation of the device at these or any other conditions beyond those indicated under “recommended operating conditions” is not implied. Exposure to absolute-maximum-rated conditions for extended periods may affect device reliability.

- NOTES: 1. The input and output voltage ratings may be exceeded if the input and output current ratings are observed.
 2. The package thermal impedance is calculated in accordance with JESD 51-7.

recommended operating conditions (see Note 3)

		SN54HC191			SN74HC191			UNIT
		MIN	NOM	MAX	MIN	NOM	MAX	
V_{CC}	Supply voltage	2	5	6	2	5	6	V
V_{IH}	High-level input voltage	$V_{CC} = 2$ V		1.5	$V_{CC} = 2$ V		1.5	V
		$V_{CC} = 4.5$ V		3.15	$V_{CC} = 4.5$ V		3.15	
		$V_{CC} = 6$ V		4.2	$V_{CC} = 6$ V		4.2	
V_{IL}	Low-level input voltage	$V_{CC} = 2$ V			0.5		0.5	V
		$V_{CC} = 4.5$ V			1.35		1.35	
		$V_{CC} = 6$ V			1.8		1.8	
V_I	Input voltage	0		V_{CC}	0		V_{CC}	V
V_O	Output voltage	0		V_{CC}	0		V_{CC}	V
$\Delta t/\Delta v$ ‡	Input transition rise/fall time	$V_{CC} = 2$ V			1000		1000	ns
		$V_{CC} = 4.5$ V			500		500	
		$V_{CC} = 6$ V			400		400	
T_A	Operating free-air temperature	–55		125	–40		85	°C

NOTE 3: All unused inputs of the device must be held at V_{CC} or GND to ensure proper device operation. Refer to the TI application report, *Implications of Slow or Floating CMOS Inputs*, literature number SCBA004.

‡ If this device is used in the threshold region (from $V_{ILmax} = 0.5$ V to $V_{IHmin} = 1.5$ V), there is a potential to go into the wrong state from induced grounding, causing double clocking. Operating with the inputs at $t_f = 1000$ ns and $V_{CC} = 2$ V does not damage the device; however, functionally, the CLK inputs are not ensured while in the shift, count, or toggle operating modes.



SN54HC191, SN74HC191

4-BIT SYNCHRONOUS UP/DOWN BINARY COUNTERS

SCLS121D – DECEMBER 1982 – REVISED OCTOBER 2003

electrical characteristics over recommended operating free-air temperature range (unless otherwise noted)

PARAMETER	TEST CONDITIONS		V _{CC}	T _A = 25°C			SN54HC191		SN74HC191		UNIT
				MIN	TYP	MAX	MIN	MAX	MIN	MAX	
V _{OH}	V _I = V _{IH} or V _{IL}	I _{OH} = -20 μA	2 V	1.9	1.998		1.9		1.9	V	
			4.5 V	4.4	4.499		4.4		4.4		
			6 V	5.9	5.999		5.9		5.9		
		I _{OH} = -4 mA	4.5 V	3.98	4.3		3.7		3.84		
		I _{OH} = -5.2 mA	6 V	5.48	5.8		5.2		5.34		
V _{OL}	V _I = V _{IH} or V _{IL}	I _{OL} = 20 μA	2 V		0.002	0.1		0.1		0.1	V
			4.5 V		0.001	0.1		0.1		0.1	
			6 V		0.001	0.1		0.1		0.1	
		I _{OL} = 4 mA	4.5 V		0.17	0.26		0.4		0.33	
		I _{OL} = 5.2 mA	6 V		0.15	0.26		0.4		0.33	
I _I	V _I = V _{CC} or 0		6 V		±0.1	±100		±1000		±1000	nA
I _{CC}	V _I = V _{CC} or 0, I _O = 0		6 V			8		160		80	μA
C _i			2 V to 6 V		3	10		10		10	pF



SN54HC191, SN74HC191

4-BIT SYNCHRONOUS UP/DOWN BINARY COUNTERS

SCLS121D – DECEMBER 1982 – REVISED OCTOBER 2003

timing requirements over recommended operating free-air temperature range (unless otherwise noted)

		V _{CC}	T _A = 25°C		SN54HC191		SN74HC191		UNIT
			MIN	MAX	MIN	MAX	MIN	MAX	
f _{clock}	Clock frequency	2 V	4.2		2.8		3.3		MHz
		4.5 V	21		14		17		
		6 V	24		16		19		
t _w	$\overline{\text{LOAD}}$ low	2 V	120		180		150	ns	
		4.5 V	24		36		30		
		6 V	21		31		26		
	CLK high or low	2 V	120		180		150		
		4.5 V	24		36		30		
		6 V	21		31		26		
t _{su}	Data before $\overline{\text{LOAD}}\uparrow$	2 V	150		230		188	ns	
		4.5 V	30		46		38		
		6 V	25		38		32		
	$\overline{\text{CTEN}}$ before CLK \uparrow	2 V	205		306		255		
		4.5 V	41		61		51		
		6 V	35		53		44		
	D/ $\overline{\text{U}}$ before CLK \uparrow	2 V	205		306		255		
		4.5 V	41		61		51		
		6 V	35		53		44		
	$\overline{\text{LOAD}}$ inactive before CLK \uparrow	2 V	150		225		190		
		4.5 V	30		45		38		
		6 V	25		38		32		
t _h	Data after $\overline{\text{LOAD}}\uparrow$	2 V	5		5		5	ns	
		4.5 V	5		5		5		
		6 V	5		5		5		
	$\overline{\text{CTEN}}$ after CLK \uparrow	2 V	5		5		5		
		4.5 V	5		5		5		
		6 V	5		5		5		
	D/ $\overline{\text{U}}$ after CLK \uparrow	2 V	5		5		5		
		4.5 V	5		5		5		
		6 V	5		5		5		

SN54HC191, SN74HC191

4-BIT SYNCHRONOUS UP/DOWN BINARY COUNTERS

SCLS121D – DECEMBER 1982 – REVISED OCTOBER 2003

switching characteristics over recommended operating free-air temperature range, $C_L = 50$ pF (unless otherwise noted) (see Figure 1)

PARAMETER	FROM (INPUT)	TO (OUTPUT)	V _{CC}	T _A = 25°C			SN54HC191		SN74HC191		UNIT	
				MIN	TYP	MAX	MIN	MAX	MIN	MAX		
f _{max}			2 V	4.2	8		2.8		3.3	MHz		
			4.5 V	21	42		14		17			
			6 V	24	48		16		19			
t _{pd}	$\overline{\text{LOAD}}$	Any Q	2 V		130	264		396		330	ns	
			4.5 V		40	53		79		66		
			6 V		33	45		67		56		
	A, B, C, or D	Q _A , Q _B , Q _C , or Q _D	2 V		135	240		360		300		
			4.5 V		36	48		72		60		
			6 V		30	41		61		51		
			$\overline{\text{RCO}}$	2 V		58	120		180			150
				4.5 V		17	24		36			30
				6 V		14	21		31			26
	CLK	Any Q	2 V		107	192		288		240		
			4.5 V		31	38		58		48		
			6 V		26	32		49		41		
			MAX/MIN	2 V		123	252		378			315
				4.5 V		39	50		76			63
				6 V		32	43		65			54
	D/ $\overline{\text{U}}$	$\overline{\text{RCO}}$	2 V		102	228		342		285		
			4.5 V		29	46		68		57		
			6 V		24	38		59		49		
		MAX/MIN	2 V		86	192		288		240		
			4.5 V		24	38		58		48		
			6 V		20	32		49		41		
	$\overline{\text{CTEN}}$	$\overline{\text{RCO}}$	2 V		50	132		198		165		
			4.5 V		15	26		40		33		
			6 V		13	23		34		28		
t _t		Any	2 V		38	75		110		95	ns	
			4.5 V		8	15		22		19		
			6 V		6	13		19		16		

operating characteristics, T_A = 25°C

PARAMETER	TEST CONDITIONS	TYP	UNIT
C _{pd} Power dissipation capacitance	No load	50	pF



PARAMETER MEASUREMENT INFORMATION

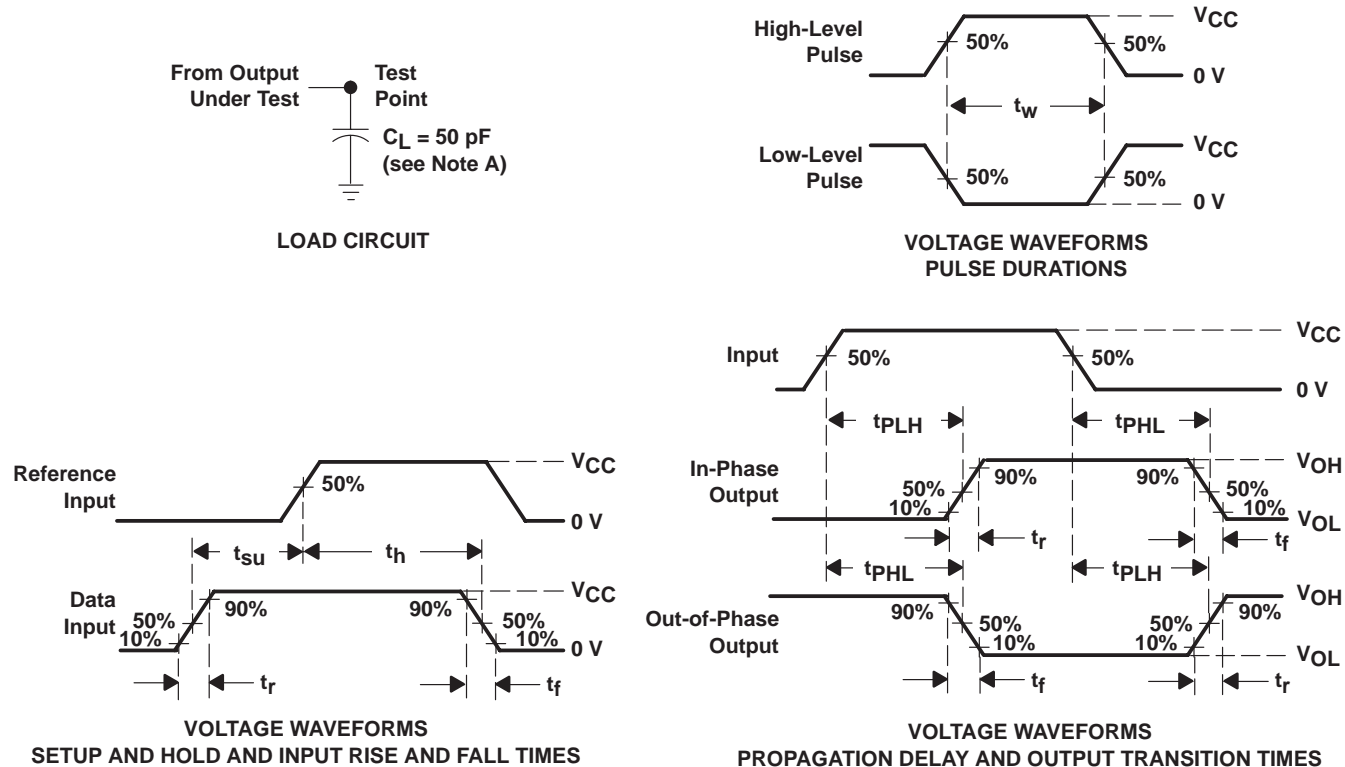

- NOTES:
- A. C_L includes probe and test-fixture capacitance.
 - B. Phase relationships between waveforms were chosen arbitrarily. All input pulses are supplied by generators having the following characteristics: $PRR \leq 1 \text{ MHz}$, $Z_O = 50 \Omega$, $t_r = 6 \text{ ns}$, $t_f = 6 \text{ ns}$.
 - C. For clock inputs, f_{max} is measured when the input duty cycle is 50%.
 - D. The outputs are measured one at a time with one input transition per measurement.
 - E. t_{PLH} and t_{PHL} are the same as t_{pd} .

Figure 1. Load Circuit and Voltage Waveforms

PACKAGING INFORMATION

Orderable Device	Status (1)	Package Type	Package Drawing	Pins	Package Qty	Eco Plan (2)	Lead/Ball Finish (6)	MSL Peak Temp (3)	Op Temp (°C)	Device Marking (4/5)	Samples
5962-86891012A	ACTIVE	LCCC	FK	20	1	TBD	POST-PLATE	N / A for Pkg Type	-55 to 125	5962- 86891012A SNJ54HC 191FK	Samples
5962-8689101EA	ACTIVE	CDIP	J	16	1	TBD	A42	N / A for Pkg Type	-55 to 125	5962-8689101EA SNJ54HC191J	Samples
SN54HC191J	ACTIVE	CDIP	J	16	1	TBD	A42	N / A for Pkg Type	-55 to 125	SN54HC191J	Samples
SN74HC191D	ACTIVE	SOIC	D	16	40	Green (RoHS & no Sb/Br)	CU NIPDAU	Level-1-260C-UNLIM	-40 to 85	HC191	Samples
SN74HC191DR	ACTIVE	SOIC	D	16	2500	Green (RoHS & no Sb/Br)	CU NIPDAU	Level-1-260C-UNLIM	-40 to 85	HC191	Samples
SN74HC191DRG4	ACTIVE	SOIC	D	16	2500	Green (RoHS & no Sb/Br)	CU NIPDAU	Level-1-260C-UNLIM	-40 to 85	HC191	Samples
SN74HC191DT	ACTIVE	SOIC	D	16	250	Green (RoHS & no Sb/Br)	CU NIPDAU	Level-1-260C-UNLIM	-40 to 85	HC191	Samples
SN74HC191N	ACTIVE	PDIP	N	16	25	Green (RoHS & no Sb/Br)	CU NIPDAU	N / A for Pkg Type	-40 to 85	SN74HC191N	Samples
SN74HC191NE4	ACTIVE	PDIP	N	16	25	Green (RoHS & no Sb/Br)	CU NIPDAU	N / A for Pkg Type	-40 to 85	SN74HC191N	Samples
SN74HC191NSR	ACTIVE	SO	NS	16	2000	Green (RoHS & no Sb/Br)	CU NIPDAU	Level-1-260C-UNLIM	-40 to 85	HC191	Samples
SNJ54HC191FK	ACTIVE	LCCC	FK	20	1	TBD	POST-PLATE	N / A for Pkg Type	-55 to 125	5962- 86891012A SNJ54HC 191FK	Samples
SNJ54HC191J	ACTIVE	CDIP	J	16	1	TBD	A42	N / A for Pkg Type	-55 to 125	5962-8689101EA SNJ54HC191J	Samples

(1) The marketing status values are defined as follows:

ACTIVE: Product device recommended for new designs.

LIFEBUY: TI has announced that the device will be discontinued, and a lifetime-buy period is in effect.

NRND: Not recommended for new designs. Device is in production to support existing customers, but TI does not recommend using this part in a new design.

PREVIEW: Device has been announced but is not in production. Samples may or may not be available.

OBSOLETE: TI has discontinued the production of the device.

(2) **RoHS:** TI defines "RoHS" to mean semiconductor products that are compliant with the current EU RoHS requirements for all 10 RoHS substances, including the requirement that RoHS substance do not exceed 0.1% by weight in homogeneous materials. Where designed to be soldered at high temperatures, "RoHS" products are suitable for use in specified lead-free processes. TI may reference these types of products as "Pb-Free".

RoHS Exempt: TI defines "RoHS Exempt" to mean products that contain lead but are compliant with EU RoHS pursuant to a specific EU RoHS exemption.

Green: TI defines "Green" to mean the content of Chlorine (Cl) and Bromine (Br) based flame retardants meet JS709B low halogen requirements of ≤ 1000 ppm threshold. Antimony trioxide based flame retardants must also meet the ≤ 1000 ppm threshold requirement.

(3) **MSL, Peak Temp.** - The Moisture Sensitivity Level rating according to the JEDEC industry standard classifications, and peak solder temperature.

(4) There may be additional marking, which relates to the logo, the lot trace code information, or the environmental category on the device.

(5) Multiple Device Markings will be inside parentheses. Only one Device Marking contained in parentheses and separated by a "~" will appear on a device. If a line is indented then it is a continuation of the previous line and the two combined represent the entire Device Marking for that device.

(6) **Lead/Ball Finish** - Orderable Devices may have multiple material finish options. Finish options are separated by a vertical ruled line. Lead/Ball Finish values may wrap to two lines if the finish value exceeds the maximum column width.

Important Information and Disclaimer: The information provided on this page represents TI's knowledge and belief as of the date that it is provided. TI bases its knowledge and belief on information provided by third parties, and makes no representation or warranty as to the accuracy of such information. Efforts are underway to better integrate information from third parties. TI has taken and continues to take reasonable steps to provide representative and accurate information but may not have conducted destructive testing or chemical analysis on incoming materials and chemicals. TI and TI suppliers consider certain information to be proprietary, and thus CAS numbers and other limited information may not be available for release.

In no event shall TI's liability arising out of such information exceed the total purchase price of the TI part(s) at issue in this document sold by TI to Customer on an annual basis.

OTHER QUALIFIED VERSIONS OF SN54HC191, SN74HC191 :

● Catalog: [SN74HC191](#)

● Military: [SN54HC191](#)

NOTE: Qualified Version Definitions:

● Catalog - TI's standard catalog product

● Military - QML certified for Military and Defense Applications

TAPE AND REEL INFORMATION



QUADRANT ASSIGNMENTS FOR PIN 1 ORIENTATION IN TAPE



*All dimensions are nominal

Device	Package Type	Package Drawing	Pins	SPQ	Reel Diameter (mm)	Reel Width W1 (mm)	A0 (mm)	B0 (mm)	K0 (mm)	P1 (mm)	W (mm)	Pin1 Quadrant
SN74HC191DR	SOIC	D	16	2500	330.0	16.4	6.5	10.3	2.1	8.0	16.0	Q1
SN74HC191NSR	SO	NS	16	2000	330.0	16.4	8.2	10.5	2.5	12.0	16.0	Q1

TAPE AND REEL BOX DIMENSIONS

*All dimensions are nominal

Device	Package Type	Package Drawing	Pins	SPQ	Length (mm)	Width (mm)	Height (mm)
SN74HC191DR	SOIC	D	16	2500	333.2	345.9	28.6
SN74HC191NSR	SO	NS	16	2000	367.0	367.0	38.0

FK (S-CQCC-N**)

LEADLESS CERAMIC CHIP CARRIER

28 TERMINAL SHOWN



NO. OF TERMINALS **	A		B	
	MIN	MAX	MIN	MAX
20	0.342 (8,69)	0.358 (9,09)	0.307 (7,80)	0.358 (9,09)
28	0.442 (11,23)	0.458 (11,63)	0.406 (10,31)	0.458 (11,63)
44	0.640 (16,26)	0.660 (16,76)	0.495 (12,58)	0.560 (14,22)
52	0.740 (18,78)	0.761 (19,32)	0.495 (12,58)	0.560 (14,22)
68	0.938 (23,83)	0.962 (24,43)	0.850 (21,6)	0.858 (21,8)
84	1.141 (28,99)	1.165 (29,59)	1.047 (26,6)	1.063 (27,0)



4040140/D 01/11

- NOTES:
- All linear dimensions are in inches (millimeters).
 - This drawing is subject to change without notice.
 - This package can be hermetically sealed with a metal lid.
 - Falls within JEDEC MS-004

D (R-PDSO-G16)

PLASTIC SMALL OUTLINE



- NOTES:
- A. All linear dimensions are in inches (millimeters).
 - B. This drawing is subject to change without notice.
 - C. Body length does not include mold flash, protrusions, or gate burrs. Mold flash, protrusions, or gate burrs shall not exceed 0.006 (0,15) each side.
 - D. Body width does not include interlead flash. Interlead flash shall not exceed 0.017 (0,43) each side.
 - E. Reference JEDEC MS-012 variation AC.

D (R-PDSO-G16)

PLASTIC SMALL OUTLINE



- NOTES:
- All linear dimensions are in millimeters.
 - This drawing is subject to change without notice.
 - Publication IPC-7351 is recommended for alternate designs.
 - Laser cutting apertures with trapezoidal walls and also rounding corners will offer better paste release. Customers should contact their board assembly site for stencil design recommendations. Refer to IPC-7525 for other stencil recommendations.
 - Customers should contact their board fabrication site for solder mask tolerances between and around signal pads.

MECHANICAL DATA

NS (R-PDSO-G**)

PLASTIC SMALL-OUTLINE PACKAGE

14-PINS SHOWN



- NOTES:
- A. All linear dimensions are in millimeters.
 - B. This drawing is subject to change without notice.
 - C. Body dimensions do not include mold flash or protrusion, not to exceed 0,15.

J (R-GDIP-T**)

14 LEADS SHOWN

CERAMIC DUAL IN-LINE PACKAGE



DIM \ PINS **	14	16	18	20
A	0.300 (7,62) BSC	0.300 (7,62) BSC	0.300 (7,62) BSC	0.300 (7,62) BSC
B MAX	0.785 (19,94)	.840 (21,34)	0.960 (24,38)	1.060 (26,92)
B MIN	—	—	—	—
C MAX	0.300 (7,62)	0.300 (7,62)	0.310 (7,87)	0.300 (7,62)
C MIN	0.245 (6,22)	0.245 (6,22)	0.220 (5,59)	0.245 (6,22)



4040083/F 03/03



- NOTES:
- All linear dimensions are in inches (millimeters).
 - This drawing is subject to change without notice.
 - This package is hermetically sealed with a ceramic lid using glass frit.
 - Index point is provided on cap for terminal identification only on press ceramic glass frit seal only.
 - Falls within MIL STD 1835 GDIP1-T14, GDIP1-T16, GDIP1-T18 and GDIP1-T20.

N (R-PDIP-T**)

PLASTIC DUAL-IN-LINE PACKAGE

16 PINS SHOWN



- NOTES:
- A. All linear dimensions are in inches (millimeters).
 - B. This drawing is subject to change without notice.
 -  Falls within JEDEC MS-001, except 18 and 20 pin minimum body length (Dim A).
 -  The 20 pin end lead shoulder width is a vendor option, either half or full width.

IMPORTANT NOTICE AND DISCLAIMER

TI PROVIDES TECHNICAL AND RELIABILITY DATA (INCLUDING DATASHEETS), DESIGN RESOURCES (INCLUDING REFERENCE DESIGNS), APPLICATION OR OTHER DESIGN ADVICE, WEB TOOLS, SAFETY INFORMATION, AND OTHER RESOURCES "AS IS" AND WITH ALL FAULTS, AND DISCLAIMS ALL WARRANTIES, EXPRESS AND IMPLIED, INCLUDING WITHOUT LIMITATION ANY IMPLIED WARRANTIES OF MERCHANTABILITY, FITNESS FOR A PARTICULAR PURPOSE OR NON-INFRINGEMENT OF THIRD PARTY INTELLECTUAL PROPERTY RIGHTS.

These resources are intended for skilled developers designing with TI products. You are solely responsible for (1) selecting the appropriate TI products for your application, (2) designing, validating and testing your application, and (3) ensuring your application meets applicable standards, and any other safety, security, or other requirements. These resources are subject to change without notice. TI grants you permission to use these resources only for development of an application that uses the TI products described in the resource. Other reproduction and display of these resources is prohibited. No license is granted to any other TI intellectual property right or to any third party intellectual property right. TI disclaims responsibility for, and you will fully indemnify TI and its representatives against, any claims, damages, costs, losses, and liabilities arising out of your use of these resources.

TI's products are provided subject to TI's Terms of Sale (www.ti.com/legal/termsofsale.html) or other applicable terms available either on ti.com or provided in conjunction with such TI products. TI's provision of these resources does not expand or otherwise alter TI's applicable warranties or warranty disclaimers for TI products.

Mailing Address: Texas Instruments, Post Office Box 655303, Dallas, Texas 75265
Copyright © 2019, Texas Instruments Incorporated

Looking for pricing, stock, or lifecycle information?

Click below to explore more details on WIN SOURCE:

 [View SN74HC191N on WIN SOURCE](#)

 [Texas Instruments](#) Information

Optimize Your Supply Chain with WIN SOURCE Solutions

-  Global Sourcing Solution
-  Obsolete Management
-  Cost Control Management
-  Shortage Management
-  Alternative Solution
-  Excess Inventory Management