



**THE DATASHEET OF  
SN74LVC1T45QDCKRQ1**



## SN74LVC1T45-Q1 1.65-V to 5.5-V Single-Bit Dual-Supply Level Shifter

### 1 Features

- Qualified for Automotive Applications
- AEC-Q100 Qualified With the Following Results:
  - Device Temperature Grade 1:  $-40^{\circ}\text{C}$  to  $+125^{\circ}\text{C}$  Ambient Operating Temperature Range
  - Device HBM ESD Classification Level H2
  - Device CDM ESD Classification Level C3B
- Fully Configurable Dual-Rail Design Allows Each Port to Operate Over the Full 1.65-V to 5.5-V Power-Supply Range
- $V_{CC}$  Isolation Feature – If Either  $V_{CC}$  Input Is at GND, Both Ports Are in the High-Impedance State
- DIR Input Circuit Referenced to  $V_{CCA}$
- $\pm 24\text{-mA}$  Output Drive at 3.3 V
- $I_{off}$  Supports Partial-Power-Down Mode Operation
- Maximum Data Rates
  - 420 Mbps (3.3-V to 5-V Translation)
  - 210 Mbps (Translate to 3.3 V)
  - 140 Mbps (Translate to 2.5 V)
  - 75 Mbps (Translate to 1.8 V)

### 2 Applications

- Head Units
- ADAS – Cameras
- Telematics

### 3 Description

The SN74LVC1T45-Q1 device is a single-bit, noninverting bus transceiver that uses two separate configurable power supply rails. The A-port is designed to track  $V_{CCA}$ .  $V_{CCA}$  accepts any supply voltage from 1.65 V to 5.5 V. The B-port is designed to track  $V_{CCB}$ .  $V_{CCB}$  accepts any supply voltage from 1.65 V to 5.5 V. This allows for universal low-voltage bidirectional translation between any of the 1.8-V, 2.5-V, 3.3-V, and 5-V voltage nodes.

The SN74LVC1T45-Q1 device is a single-bit, non-inverting level translator. The fully configurable dual-rail design allows each port to operate over the full 1.65-V to 5.5-V power supply range. It is ideal for applications that need a wide bidirectional translation range.

The SN74LVC1T45-Q1 is designed so that the DIR input is powered by  $V_{CCA}$ .

This device is fully specified for partial-power-down applications using  $I_{off}$ . The  $I_{off}$  circuitry disables the outputs, preventing damaging current backflow through the device when it is powered down.

The  $V_{CC}$  isolation feature assures that if either  $V_{CC}$  input is at GND, then both ports are in the high-impedance state.

#### Device Information<sup>(1)</sup>

PART NUMBER	PACKAGE	BODY SIZE (NOM)
SN74LVC1T45-Q1	SC70 (6)	1.25 mm x 2.00 mm

(1) For all available packages, see the orderable addendum at the end of the data sheet.

#### Logic Diagram (Positive Logic)

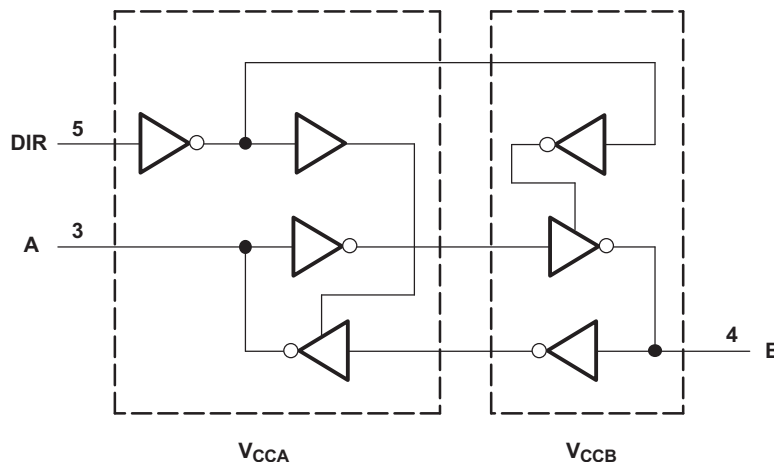

Copyright © 2016, Texas Instruments Incorporated



## Table of Contents

<b>1 Features</b> ..... 1 <b>2 Applications</b> ..... 1 <b>3 Description</b> ..... 1 <b>4 Revision History</b> ..... 2 <b>5 Pin Configuration and Functions</b> ..... 3 <b>6 Specifications</b> ..... 4 6.1 Absolute Maximum Ratings ..... 4 6.2 ESD Ratings ..... 4 6.3 Recommended Operating Conditions ..... 4 6.4 Thermal Information ..... 5 6.5 Electrical Characteristics ..... 6 6.6 Switching Characteristics: $V_{CCA} = 1.8\text{ V} \pm 0.15\text{ V}$ ..... 7 6.7 Switching Characteristics: $V_{CCA} = 2.5\text{ V} \pm 0.2\text{ V}$ ..... 8 6.8 Switching Characteristics: $V_{CCA} = 3.3\text{ V} \pm 0.3\text{ V}$ ..... 9 6.9 Switching Characteristics: $V_{CCA} = 5\text{ V} \pm 0.5\text{ V}$ ..... 11 6.10 Typical Characteristics ..... 13 <b>7 Parameter Measurement Information</b> ..... 16 <b>8 Detailed Description</b> ..... 17 8.1 Overview ..... 17	8.2 Functional Block Diagram ..... 17 8.3 Feature Description ..... 17 8.4 Device Functional Modes ..... 17 <b>9 Application and Implementation</b> ..... 18 9.1 Application Information ..... 18 9.2 Typical Applications ..... 18 <b>10 Power Supply Recommendations</b> ..... 20 <b>11 Layout</b> ..... 21 11.1 Layout Guidelines ..... 21 11.2 Layout Example ..... 21 <b>12 Device and Documentation Support</b> ..... 22 12.1 Documentation Support ..... 22 12.2 Receiving Notification of Documentation Updates ..... 22 12.3 Community Resources ..... 22 12.4 Trademarks ..... 22 12.5 Electrostatic Discharge Caution ..... 22 12.6 Glossary ..... 22 <b>13 Mechanical, Packaging, and Orderable Information</b> ..... 22
---	---

## 4 Revision History

NOTE: Page numbers for previous revisions may differ from page numbers in the current version.

Changes from Revision C (September 2016) to Revision D	Page
• Added Junction temperature, $T_J$ in <i>Absolute Maximum Ratings</i> .....	4
• Added revised steps for power-up sequence in <i>Power Supply Recommendations</i> .....	20

Changes from Revision B (September 2012) to Revision C	Page
• Changed data sheet title From: SN74LVC1T45-Q1 Single-Bit Dual-Supply Bus Transceiver With Configurable Voltage Translation and 3-State Outputs To: SN74LVC1T45-Q1 1.65-V to 5.5-V Single-Bit Dual-Supply Level Shifter .....	1
• Added <i>Device Information</i> table, <i>ESD Ratings</i> table, <i>Feature Description</i> section, <i>Device Functional Modes</i> section, <i>Application and Implementation</i> section, <i>Power Supply Recommendations</i> section, <i>Layout</i> section, <i>Device and Documentation Support</i> section, and <i>Mechanical, Packaging, and Orderable Information</i> section.....	1
• Deleted Ordering Information table; see POA the end of the data sheet.....	1

## 5 Pin Configuration and Functions

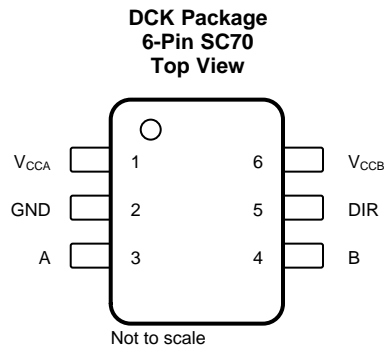

See mechanical drawings for dimensions.

### Pin Functions

PIN		TYPE <sup>(1)</sup>	DESCRIPTION
NAME	NO.		
A	3	I/O	Output level depends on $V_{CC1}$ voltage
B	4	I/O	Input threshold value depends on $V_{CC2}$ voltage
DIR	5	I	GND (low level) determines B-port to A-port direction
GND	2	G	Device GND
$V_{CCA}$	1	P	SYSTEM-1 supply voltage (1.65 V to 5.5 V)
$V_{CCB}$	6	P	SYSTEM-2 supply voltage (1.65 V to 5.5 V)

(1) G = Ground, I = Input, O = Output, P = Power

## 6 Specifications

### 6.1 Absolute Maximum Ratings

 over operating free-air temperature range (unless otherwise noted)<sup>(1)</sup>

		MIN	MAX	UNIT
Supply voltage, $V_{CCA}$ , $V_{CCB}$		-0.5	6.5	V
Input voltage, $V_I$ <sup>(2)</sup>		-0.5	6.5	V
Voltage applied to any output in the high-impedance or power-off state, $V_O$ <sup>(2)</sup>		-0.5	6.5	V
Voltage applied to any output in the high or low state, $V_O$ <sup>(2)(3)</sup>	A port	-0.5	$V_{CCA} + 0.5$	V
	B port	-0.5	$V_{CCB} + 0.5$	
Input clamp current, $I_{IK}$ ( $V_I < 0$ )			-50	mA
Output clamp current, $I_{OK}$ ( $V_O < 0$ )			-50	mA
Continuous output current, $I_O$			±50	mA
Continuous current through $V_{CC}$ or GND			±100	mA
Junction temperature, $T_J$			150	°C
Storage temperature, $T_{stg}$		-65	150	°C

- (1) Stresses beyond those listed under *Absolute Maximum Ratings* may cause permanent damage to the device. These are stress ratings only, which do not imply functional operation of the device at these or any other conditions beyond those indicated under *Recommended Operating Conditions*. Exposure to absolute-maximum-rated conditions for extended periods may affect device reliability.
- (2) The input and output negative-voltage ratings may be exceeded if the input and output clamp-current ratings are observed.
- (3) The value of  $V_{CC}$  is provided in *Recommended Operating Conditions*.

### 6.2 ESD Ratings

		VALUE	UNIT
$V_{(ESD)}$ Electrostatic discharge	Human-body model (HBM), per ANSI/ESDA/JEDEC JS-001 <sup>(1)</sup>	±2000	V
	Charged-device model (CDM), per JEDEC specification JESD22-C101 <sup>(2)</sup>	±750	

- (1) JEDEC document JEP155 states that 500-V HBM allows safe manufacturing with a standard ESD control process.
- (2) JEDEC document JEP157 states that 250-V CDM allows safe manufacturing with a standard ESD control process.

### 6.3 Recommended Operating Conditions

 See<sup>(1)(2)(3)</sup>

		MIN	MAX	UNIT
$V_{CCA}$	Supply voltage	1.65	5.5	V
$V_{CCB}$	Supply voltage	1.65	5.5	V
$V_{IH}$	High-level input voltage, data inputs <sup>(4)</sup>	$V_{CCI} = 1.65\text{ V to }1.95\text{ V}$	$V_{CCI} \times 0.65$	V
		$V_{CCI} = 2.3\text{ V to }2.7\text{ V}$	1.7	
		$V_{CCI} = 3\text{ V to }3.6\text{ V}$	2	
		$V_{CCI} = 4.5\text{ V to }5.5\text{ V}$	$V_{CCI} \times 0.7$	
$V_{IL}$	Low-level input voltage, data inputs <sup>(4)</sup>	$V_{CCI} = 1.65\text{ V to }1.95\text{ V}$	$V_{CCI} \times 0.35$	V
		$V_{CCI} = 2.3\text{ V to }2.7\text{ V}$	0.7	
		$V_{CCI} = 3\text{ V to }3.6\text{ V}$	0.8	
		$V_{CCI} = 4.5\text{ V to }5.5\text{ V}$	$V_{CCI} \times 0.3$	
$V_{IH}$	High-level input voltage, DIR (referenced to $V_{CCA}$ ) <sup>(5)</sup>	$V_{CCI} = 1.65\text{ V to }1.95\text{ V}$	$V_{CCA} \times 0.65$	V
		$V_{CCI} = 2.3\text{ V to }2.7\text{ V}$	1.7	
		$V_{CCI} = 3\text{ V to }3.6\text{ V}$	2	
		$V_{CCI} = 4.5\text{ V to }5.5\text{ V}$	$V_{CCA} \times 0.7$	

- (1)  $V_{CCI}$  is the  $V_{CC}$  associated with the input port.
- (2)  $V_{CCO}$  is the  $V_{CC}$  associated with the output port.
- (3) All unused data inputs of the device must be held at  $V_{CCI}$  or GND to assure proper device operation. See *Implications of Slow or Floating CMOS Inputs* (SCBA004).
- (4) For  $V_{CCI}$  values not specified in the data sheet,  $V_{IH\ min} = V_{CCI} \times 0.7\text{ V}$ ,  $V_{IL\ max} = V_{CCI} \times 0.3\text{ V}$ .
- (5) For  $V_{CCI}$  values not specified in the data sheet,  $V_{IH\ min} = V_{CCA} \times 0.7\text{ V}$ ,  $V_{IL\ max} = V_{CCA} \times 0.3\text{ V}$ .

**Recommended Operating Conditions (continued)**

 See <sup>(1)(2)(3)</sup>

		MIN	MAX	UNIT	
V <sub>IL</sub>	Low-level input voltage, DIR (referenced to V <sub>CCA</sub> ) <sup>(5)</sup>	V <sub>CCI</sub> = 1.65 V to 1.95 V	V <sub>CCA</sub> × 0.35	V	
		V <sub>CCI</sub> = 2.3 V to 2.7 V	0.7		
		V <sub>CCI</sub> = 3 V to 3.6 V	0.8		
		V <sub>CCI</sub> = 4.5 V to 5.5 V	V <sub>CCA</sub> × 0.3		
V <sub>I</sub>	Input voltage	0	5.5	V	
V <sub>O</sub>	Output voltage	0	V <sub>CCO</sub>	V	
I <sub>OH</sub>	High-level output current	V <sub>CCO</sub> = 1.65 V to 1.95 V	–4	mA	
		V <sub>CCO</sub> = 2.3 V to 2.7 V	–8		
		V <sub>CCO</sub> = 3 V to 3.6 V	–24		
		V <sub>CCO</sub> = 4.5 V to 5.5 V	–32		
I <sub>OL</sub>	Low-level output current	V <sub>CCO</sub> = 1.65 V to 1.95 V	4	mA	
		V <sub>CCO</sub> = 2.3 V to 2.7 V	8		
		V <sub>CCO</sub> = 3 V to 3.6 V	24		
		V <sub>CCO</sub> = 4.5 V to 5.5 V	32		
Δt/Δv	Input transition rise or fall rate	Data inputs	V <sub>CCI</sub> = 1.65 V to 1.95 V	20	ns/V
			V <sub>CCI</sub> = 2.3 V to 2.7 V	20	
			V <sub>CCI</sub> = 3 V to 3.6 V	10	
			V <sub>CCI</sub> = 4.5 V to 5.5 V	5	
	Control inputs, V <sub>CCI</sub> = 1.65 V to 5.5 V	5			
T <sub>A</sub>	Operating free-air temperature	–40	125	°C	

**6.4 Thermal Information**

THERMAL METRIC <sup>(1)</sup>		SN74LVC1T45-Q1	UNIT
		DCK (SC70)	
		6 PINS	
R <sub>θJA</sub>	Junction-to-ambient thermal resistance	286.8	°C/W
R <sub>θJC(top)</sub>	Junction-to-case (top) thermal resistance	93.9	°C/W
R <sub>θJB</sub>	Junction-to-board thermal resistance	95.5	°C/W
ψ <sub>JT</sub>	Junction-to-top characterization parameter	1.9	°C/W
ψ <sub>JB</sub>	Junction-to-board characterization parameter	94.7	°C/W
R <sub>θJC(bot)</sub>	Junction-to-case (bottom) thermal resistance	—	°C/W

(1) For more information about traditional and new thermal metrics, see the [Semiconductor and IC Package Thermal Metrics](#) application report.

## 6.5 Electrical Characteristics

 over operating free-air temperature range with all limits at  $T_A = -40^\circ\text{C}$  to  $125^\circ\text{C}$  (unless otherwise noted)<sup>(1)(2)</sup>

PARAMETER	TEST CONDITIONS		MIN	TYP	MAX	UNIT	
$V_{OH}$	$V_I = V_{IH}$	$I_{OH} = -100\ \mu\text{A}$ , $V_{CCA} = 1.65\ \text{V}$ to $4.5\ \text{V}$ , $V_{CCB} = 1.65\ \text{V}$ to $4.5\ \text{V}$	$V_{CCO} - 0.1$			V	
		$I_{OH} = -4\ \text{mA}$ , $V_{CCA} = 1.65\ \text{V}$ , $V_{CCB} = 1.65\ \text{V}$	1.2				
		$I_{OH} = -8\ \text{mA}$ , $V_{CCA} = 2.3\ \text{V}$ , $V_{CCB} = 2.3\ \text{V}$	1.9				
		$I_{OH} = -24\ \text{mA}$ , $V_{CCA} = 3\ \text{V}$ , $V_{CCB} = 3\ \text{V}$	2.3				
		$I_{OH} = -32\ \text{mA}$ , $V_{CCA} = 4.5\ \text{V}$ , $V_{CCB} = 4.5\ \text{V}$	3.8				
$V_{OL}$	$V_I = V_{IL}$	$I_{OL} = 100\ \mu\text{A}$ , $V_{CCA} = 1.65\ \text{V}$ to $4.5\ \text{V}$ , $V_{CCB} = 1.65\ \text{V}$ to $4.5\ \text{V}$			0.1	V	
		$I_{OL} = 4\ \text{mA}$ , $V_{CCA} = 1.65\ \text{V}$ , $V_{CCB} = 1.65\ \text{V}$			0.45		
		$I_{OL} = 8\ \text{mA}$ , $V_{CCA} = 2.3\ \text{V}$ , $V_{CCB} = 2.3\ \text{V}$			0.4		
		$I_{OL} = 24\ \text{mA}$ , $V_{CCA} = 3\ \text{V}$ , $V_{CCB} = 3\ \text{V}$			0.65		
		$I_{OL} = 32\ \text{mA}$ , $V_{CCA} = 4.5\ \text{V}$ , $V_{CCB} = 4.5\ \text{V}$			0.65		
$I_I$	DIR at $V_I = V_{CCA}$ or GND, $V_{CCA} = 1.65\ \text{V}$ to $5.5\ \text{V}$ , $V_{CCB} = 1.65\ \text{V}$ to $5.5\ \text{V}$	$T_A = 25^\circ\text{C}$			$\pm 1$	$\mu\text{A}$	
		$T_A = -40^\circ\text{C}$ to $125^\circ\text{C}$			$\pm 4$		
$I_{off}$	$V_I$ or $V_O = 0$ to $5.5\ \text{V}$	A port at $V_{CCA} = 0\ \text{V}$ , $V_{CCB} = 0$ to $5.5\ \text{V}$	$T_A = 25^\circ\text{C}$			$\pm 1$	$\mu\text{A}$
			$T_A = -40^\circ\text{C}$ to $125^\circ\text{C}$			$\pm 10$	
		B port at $V_{CCA} = 0$ to $5.5\ \text{V}$ , $V_{CCB} = 0\ \text{V}$	$T_A = 25^\circ\text{C}$			$\pm 1$	
			$T_A = -40^\circ\text{C}$ to $125^\circ\text{C}$			$\pm 10$	
$I_{OZ}$	A or B port at $V_O = V_{CCO}$ or GND, $V_{CCA} = 1.65\ \text{V}$ to $5.5\ \text{V}$ , $V_{CCB} = 1.65\ \text{V}$ to $5.5\ \text{V}$	$T_A = 25^\circ\text{C}$			$\pm 1$	$\mu\text{A}$	
		$T_A = -40^\circ\text{C}$ to $125^\circ\text{C}$			$\pm 10$		
$I_{CCA}$	$V_I = V_{CCI}$ or GND, $I_O = 0$	$V_{CCA} = 1.65\ \text{V}$ to $5.5\ \text{V}$ , $V_{CCB} = 1.65\ \text{V}$ to $5.5\ \text{V}$		10		$\mu\text{A}$	
		$V_{CCA} = 5.5\ \text{V}$ , $V_{CCB} = 0\ \text{V}$		4			
		$V_{CCA} = 0\ \text{V}$ , $V_{CCB} = 5.5\ \text{V}$		-10			
$I_{CCB}$	$V_I = V_{CCI}$ or GND, $I_O = 0$	$V_{CCA} = 1.65\ \text{V}$ to $5.5\ \text{V}$ , $V_{CCB} = 1.65\ \text{V}$ to $5.5\ \text{V}$		10		$\mu\text{A}$	
		$V_{CCA} = 5.5\ \text{V}$ , $V_{CCB} = 0\ \text{V}$		-10			
		$V_{CCA} = 0\ \text{V}$ , $V_{CCB} = 5.5\ \text{V}$		4			
$I_{CCA} + I_{CCB}$	$V_I = V_{CCI}$ or GND, $I_O = 0$ , $V_{CCA} = 1.65\ \text{V}$ to $5.5\ \text{V}$ , $V_{CCB} = 1.65\ \text{V}$ to $5.5\ \text{V}$			20		$\mu\text{A}$	
$\Delta I_{CCA}$	$V_{CCA} = 3\ \text{V}$ to $5.5\ \text{V}$ , $V_{CCB} = 3\ \text{V}$ to $5.5\ \text{V}$	A port at $V_{CCA} - 0.6\ \text{V}$ , DIR at $V_{CCA}$ , B port = open		50		$\mu\text{A}$	
		DIR at $V_{CCA} - 0.6\ \text{V}$ , B port = open, A port at $V_{CCA}$ or GND		50			
$\Delta I_{CCB}$	B port at $V_{CCB} - 0.6\ \text{V}$ , DIR at GND, A port = open, $V_{CCA} = 3\ \text{V}$ to $5.5\ \text{V}$ , $V_{CCB} = 3\ \text{V}$ to $5.5\ \text{V}$				50	$\mu\text{A}$	
$C_i$	DIR at $V_I = V_{CCA}$ or GND, $T_A = 25^\circ\text{C}$ , $V_{CCA} = 3.3\ \text{V}$ , $V_{CCB} = 3.3\ \text{V}$				2.5	pF	
$C_{io}$	A or B port at $V_O = V_{CCA/B}$ or GND, $T_A = 25^\circ\text{C}$ , $V_{CCA} = 3.3\ \text{V}$ , $V_{CCB} = 3.3\ \text{V}$				6	pF	
$C_{pdA}$ <sup>(3)</sup>	$C_L = 0\ \text{pF}$ , $f = 10\ \text{MHz}$ , $t_r = t_f = 1\ \text{ns}$	A-port input, B-port output	$V_{CCA} = V_{CCB} = 1.8\ \text{V}$	3		pF	
			$V_{CCA} = V_{CCB} = 2.5\ \text{V}$	4			
			$V_{CCA} = V_{CCB} = 3.3\ \text{V}$	4			
			$V_{CCA} = V_{CCB} = 5\ \text{V}$	4			
		B-port input, A-port output	$V_{CCA} = V_{CCB} = 1.8\ \text{V}$	18			
			$V_{CCA} = V_{CCB} = 2.5\ \text{V}$	19			
			$V_{CCA} = V_{CCB} = 3.3\ \text{V}$	20			
			$V_{CCA} = V_{CCB} = 5\ \text{V}$	21			

 (1)  $V_{CCO}$  is the  $V_{CC}$  associated with the output port.

 (2)  $V_{CCI}$  is the  $V_{CC}$  associated with the input port.

(3) Power dissipation capacitance per transceiver

## Electrical Characteristics (continued)

over operating free-air temperature range with all limits at  $T_A = -40^\circ\text{C}$  to  $125^\circ\text{C}$  (unless otherwise noted)<sup>(1)(2)</sup>

PARAMETER	TEST CONDITIONS		MIN	TYP	MAX	UNIT
$C_{pdB}^{(3)}$	A-port input, B-port output	$V_{CCA} = V_{CCB} = 1.8\text{ V}$		18		pF
		$V_{CCA} = V_{CCB} = 2.5\text{ V}$		19		
		$V_{CCA} = V_{CCB} = 3.3\text{ V}$		20		
		$V_{CCA} = V_{CCB} = 5\text{ V}$		21		
	B-port input, A-port output	$V_{CCA} = V_{CCB} = 1.8\text{ V}$		3		
		$V_{CCA} = V_{CCB} = 2.5\text{ V}$		4		
		$V_{CCA} = V_{CCB} = 3.3\text{ V}$		4		
		$V_{CCA} = V_{CCB} = 5\text{ V}$		4		

### 6.6 Switching Characteristics: $V_{CCA} = 1.8\text{ V} \pm 0.15\text{ V}$

over operating free-air temperature range (unless otherwise noted; see Figure 17)

PARAMETER	TEST CONDITIONS		MIN	TYP	MAX	UNIT
$t_{PLH}$	From A (input) to B (output)	$V_{CCB} = 1.8\text{ V} \pm 0.15\text{ V}$	3		20.7	ns
		$V_{CCB} = 2.5\text{ V} \pm 0.2\text{ V}$	2.2		13.3	
		$V_{CCB} = 3.3\text{ V} \pm 0.3\text{ V}$	1.7		11.3	
		$V_{CCB} = 5\text{ V} \pm 0.5\text{ V}$	1.4		10.2	
$t_{PHL}$	From A (input) to B (output)	$V_{CCB} = 1.8\text{ V} \pm 0.15\text{ V}$	2.8		17.3	ns
		$V_{CCB} = 2.5\text{ V} \pm 0.2\text{ V}$	2.2		11.5	
		$V_{CCB} = 3.3\text{ V} \pm 0.3\text{ V}$	1.8		10.1	
		$V_{CCB} = 5\text{ V} \pm 0.5\text{ V}$	1.7		10	
$t_{PLH}$	From B (input) to A (output)	$V_{CCB} = 1.8\text{ V} \pm 0.15\text{ V}$	3		20.7	ns
		$V_{CCB} = 2.5\text{ V} \pm 0.2\text{ V}$	2.3		19	
		$V_{CCB} = 3.3\text{ V} \pm 0.3\text{ V}$	2.1		18.5	
		$V_{CCB} = 5\text{ V} \pm 0.5\text{ V}$	1.9		18.1	
$t_{PHL}$	From B (input) to A (output)	$V_{CCB} = 1.8\text{ V} \pm 0.15\text{ V}$	2.8		17.3	ns
		$V_{CCB} = 2.5\text{ V} \pm 0.2\text{ V}$	2.1		15.9	
		$V_{CCB} = 3.3\text{ V} \pm 0.3\text{ V}$	2		15.6	
		$V_{CCB} = 5\text{ V} \pm 0.5\text{ V}$	1.8		15.2	
$t_{PHZ}$	From DIR (input) to A (output)	$V_{CCB} = 1.8\text{ V} \pm 0.15\text{ V}$	5.2		22.7	ns
		$V_{CCB} = 2.5\text{ V} \pm 0.2\text{ V}$	4.8		21.5	
		$V_{CCB} = 3.3\text{ V} \pm 0.3\text{ V}$	4.7		21.4	
		$V_{CCB} = 5\text{ V} \pm 0.5\text{ V}$	5.1		20.1	
$t_{PLZ}$	From DIR (input) to A (output)	$V_{CCB} = 1.8\text{ V} \pm 0.15\text{ V}$	2.3		13.5	ns
		$V_{CCB} = 2.5\text{ V} \pm 0.2\text{ V}$	2.1		13.5	
		$V_{CCB} = 3.3\text{ V} \pm 0.3\text{ V}$	2.4		13.7	
		$V_{CCB} = 5\text{ V} \pm 0.5\text{ V}$	3.1		13.9	
$t_{PHZ}$	From DIR (input) to B (output)	$V_{CCB} = 1.8\text{ V} \pm 0.15\text{ V}$	7.4		27.9	ns
		$V_{CCB} = 2.5\text{ V} \pm 0.2\text{ V}$	4.9		14.5	
		$V_{CCB} = 3.3\text{ V} \pm 0.3\text{ V}$	3.6		13.3	
		$V_{CCB} = 5\text{ V} \pm 0.5\text{ V}$	2.3		11.2	
$t_{PLZ}$	From DIR (input) to B (output)	$V_{CCB} = 1.8\text{ V} \pm 0.15\text{ V}$	4.2		19	ns
		$V_{CCB} = 2.5\text{ V} \pm 0.2\text{ V}$	2.2		12.2	
		$V_{CCB} = 3.3\text{ V} \pm 0.3\text{ V}$	2.3		11.4	
		$V_{CCB} = 5\text{ V} \pm 0.5\text{ V}$	2		9.4	

**Switching Characteristics:  $V_{CCA} = 1.8\text{ V} \pm 0.15\text{ V}$  (continued)**

 over operating free-air temperature range (unless otherwise noted; see [Figure 17](#))

PARAMETER	TEST CONDITIONS	MIN	TYP	MAX	UNIT
$t_{PZH}^{(1)}$	From DIR (input) to A (output)	$V_{CCB} = 1.8\text{ V} \pm 0.15\text{ V}$		39.7	ns
		$V_{CCB} = 2.5\text{ V} \pm 0.2\text{ V}$		31.2	
		$V_{CCB} = 3.3\text{ V} \pm 0.3\text{ V}$		29.9	
		$V_{CCB} = 5\text{ V} \pm 0.5\text{ V}$		27.5	
$t_{PZL}^{(1)}$	From DIR (input) to A (output)	$V_{CCB} = 1.8\text{ V} \pm 0.15\text{ V}$		45.2	ns
		$V_{CCB} = 2.5\text{ V} \pm 0.2\text{ V}$		30.4	
		$V_{CCB} = 3.3\text{ V} \pm 0.3\text{ V}$		28.9	
		$V_{CCB} = 5\text{ V} \pm 0.5\text{ V}$		26.4	
$t_{PZH}^{(1)}$	From DIR (input) to B (output)	$V_{CCB} = 1.8\text{ V} \pm 0.15\text{ V}$		34.2	ns
		$V_{CCB} = 2.5\text{ V} \pm 0.2\text{ V}$		26.8	
		$V_{CCB} = 3.3\text{ V} \pm 0.3\text{ V}$		25	
		$V_{CCB} = 5\text{ V} \pm 0.5\text{ V}$		24.1	
$t_{PZL}^{(1)}$	From DIR (input) to B (output)	$V_{CCB} = 1.8\text{ V} \pm 0.15\text{ V}$		40.7	ns
		$V_{CCB} = 2.5\text{ V} \pm 0.2\text{ V}$		33	
		$V_{CCB} = 3.3\text{ V} \pm 0.3\text{ V}$		31.5	
		$V_{CCB} = 5\text{ V} \pm 0.5\text{ V}$		30.1	

 (1) The enable time is a calculated value, derived using the formula shown in [Enable Times](#).

**6.7 Switching Characteristics:  $V_{CCA} = 2.5\text{ V} \pm 0.2\text{ V}$** 

 over operating free-air temperature range (unless otherwise noted; see [Figure 17](#))

PARAMETER	TEST CONDITIONS	MIN	TYP	MAX	UNIT
$t_{PLH}$	From A (input) to B (output)	$V_{CCB} = 1.8\text{ V} \pm 0.15\text{ V}$	2.3	19	ns
		$V_{CCB} = 2.5\text{ V} \pm 0.2\text{ V}$	1.5	11.5	
		$V_{CCB} = 3.3\text{ V} \pm 0.3\text{ V}$	1.3	9.4	
		$V_{CCB} = 5\text{ V} \pm 0.5\text{ V}$	1.1	8.1	
$t_{PHL}$	From A (input) to B (output)	$V_{CCB} = 1.8\text{ V} \pm 0.15\text{ V}$	2.1	15.9	ns
		$V_{CCB} = 2.5\text{ V} \pm 0.2\text{ V}$	1.4	10.5	
		$V_{CCB} = 3.3\text{ V} \pm 0.3\text{ V}$	1.3	8.4	
		$V_{CCB} = 5\text{ V} \pm 0.5\text{ V}$	0.9	7.6	
$t_{PLH}$	From B (input) to A (output)	$V_{CCB} = 1.8\text{ V} \pm 0.15\text{ V}$	2.2	13.3	ns
		$V_{CCB} = 2.5\text{ V} \pm 0.2\text{ V}$	1.5	11.5	
		$V_{CCB} = 3.3\text{ V} \pm 0.3\text{ V}$	1.4	11	
		$V_{CCB} = 5\text{ V} \pm 0.5\text{ V}$	1	10.5	
$t_{PHL}$	From B (input) to A (output)	$V_{CCB} = 1.8\text{ V} \pm 0.15\text{ V}$	2.2	11.5	ns
		$V_{CCB} = 2.5\text{ V} \pm 0.2\text{ V}$	1.4	10.7	
		$V_{CCB} = 3.3\text{ V} \pm 0.3\text{ V}$	1.3	10	
		$V_{CCB} = 5\text{ V} \pm 0.5\text{ V}$	0.9	9.2	
$t_{PHZ}$	From DIR (input) to A (output)	$V_{CCB} = 1.8\text{ V} \pm 0.15\text{ V}$	3	11.1	ns
		$V_{CCB} = 2.5\text{ V} \pm 0.2\text{ V}$	2.1	11.1	
		$V_{CCB} = 3.3\text{ V} \pm 0.3\text{ V}$	2.3	11.1	
		$V_{CCB} = 5\text{ V} \pm 0.5\text{ V}$	3.2	11.1	
$t_{PLZ}$	From DIR (input) to A (output)	$V_{CCB} = 1.8\text{ V} \pm 0.15\text{ V}$	1.3	8.9	ns
		$V_{CCB} = 2.5\text{ V} \pm 0.2\text{ V}$	1.3	8.9	
		$V_{CCB} = 3.3\text{ V} \pm 0.3\text{ V}$	1.3	8.9	
		$V_{CCB} = 5\text{ V} \pm 0.5\text{ V}$	1	8.8	

**Switching Characteristics:  $V_{CCA} = 2.5\text{ V} \pm 0.2\text{ V}$  (continued)**

over operating free-air temperature range (unless otherwise noted; see [Figure 17](#))

PARAMETER	TEST CONDITIONS	MIN	TYP	MAX	UNIT	
$t_{PHZ}$	From DIR (input) to B (output)	$V_{CCB} = 1.8\text{ V} \pm 0.15\text{ V}$		6.5	26.7	ns
		$V_{CCB} = 2.5\text{ V} \pm 0.2\text{ V}$		4.1	14.4	
		$V_{CCB} = 3.3\text{ V} \pm 0.3\text{ V}$		3	13.2	
		$V_{CCB} = 5\text{ V} \pm 0.5\text{ V}$		1.9	10.1	
$t_{PLZ}$	From DIR (input) to B (output)	$V_{CCB} = 1.8\text{ V} \pm 0.15\text{ V}$		3.5	21.9	ns
		$V_{CCB} = 2.5\text{ V} \pm 0.2\text{ V}$		2.2	12.6	
		$V_{CCB} = 3.3\text{ V} \pm 0.3\text{ V}$		2.5	11.4	
		$V_{CCB} = 5\text{ V} \pm 0.5\text{ V}$		1.6	8.3	
$t_{PZH}^{(1)}$	From DIR (input) to A (output)	$V_{CCB} = 1.8\text{ V} \pm 0.15\text{ V}$			35.2	ns
		$V_{CCB} = 2.5\text{ V} \pm 0.2\text{ V}$			24.1	
		$V_{CCB} = 3.3\text{ V} \pm 0.3\text{ V}$			22.4	
		$V_{CCB} = 5\text{ V} \pm 0.5\text{ V}$			18.8	
$t_{PZL}^{(1)}$	From DIR (input) to A (output)	$V_{CCB} = 1.8\text{ V} \pm 0.15\text{ V}$			38.2	ns
		$V_{CCB} = 2.5\text{ V} \pm 0.2\text{ V}$			24.9	
		$V_{CCB} = 3.3\text{ V} \pm 0.3\text{ V}$			23.2	
		$V_{CCB} = 5\text{ V} \pm 0.5\text{ V}$			19.3	
$t_{PZH}^{(1)}$	From DIR (input) to B (output)	$V_{CCB} = 1.8\text{ V} \pm 0.15\text{ V}$			27.9	ns
		$V_{CCB} = 2.5\text{ V} \pm 0.2\text{ V}$			20.4	
		$V_{CCB} = 3.3\text{ V} \pm 0.3\text{ V}$			18.3	
		$V_{CCB} = 5\text{ V} \pm 0.5\text{ V}$			16.9	
$t_{PZL}^{(1)}$	From DIR (input) to B (output)	$V_{CCB} = 1.8\text{ V} \pm 0.15\text{ V}$			27	ns
		$V_{CCB} = 2.5\text{ V} \pm 0.2\text{ V}$			21.6	
		$V_{CCB} = 3.3\text{ V} \pm 0.3\text{ V}$			19.5	
		$V_{CCB} = 5\text{ V} \pm 0.5\text{ V}$			18.7	

(1) The enable time is a calculated value, derived using the formula shown in [Enable Times](#).

**6.8 Switching Characteristics:  $V_{CCA} = 3.3\text{ V} \pm 0.3\text{ V}$** 

over operating free-air temperature range (unless otherwise noted; see [Figure 17](#))

PARAMETER	TEST CONDITIONS	MIN	TYP	MAX	UNIT	
$t_{PLH}$	From A (input) to B (output)	$V_{CCB} = 1.8\text{ V} \pm 0.15\text{ V}$		2.1	18.5	ns
		$V_{CCB} = 2.5\text{ V} \pm 0.2\text{ V}$		1.4	11	
		$V_{CCB} = 3.3\text{ V} \pm 0.3\text{ V}$		0.7	8.8	
		$V_{CCB} = 5\text{ V} \pm 0.5\text{ V}$		0.7	7.4	
$t_{PHL}$	From A (input) to B (output)	$V_{CCB} = 1.8\text{ V} \pm 0.15\text{ V}$		2	15.6	ns
		$V_{CCB} = 2.5\text{ V} \pm 0.2\text{ V}$		1.3	10	
		$V_{CCB} = 3.3\text{ V} \pm 0.3\text{ V}$		0.8	8	
		$V_{CCB} = 5\text{ V} \pm 0.5\text{ V}$		0.7	7	
$t_{PLH}$	From B (input) to A (output)	$V_{CCB} = 1.8\text{ V} \pm 0.15\text{ V}$		1.7	11.3	ns
		$V_{CCB} = 2.5\text{ V} \pm 0.2\text{ V}$		1.3	9.4	
		$V_{CCB} = 3.3\text{ V} \pm 0.3\text{ V}$		0.7	8.8	
		$V_{CCB} = 5\text{ V} \pm 0.5\text{ V}$		0.6	8.4	
$t_{PHL}$	From B (input) to A (output)	$V_{CCB} = 1.8\text{ V} \pm 0.15\text{ V}$		1.8	10.1	ns
		$V_{CCB} = 2.5\text{ V} \pm 0.2\text{ V}$		1.3	8.4	
		$V_{CCB} = 3.3\text{ V} \pm 0.3\text{ V}$		0.8	8	
		$V_{CCB} = 5\text{ V} \pm 0.5\text{ V}$		0.7	7.5	

**Switching Characteristics:  $V_{CCA} = 3.3\text{ V} \pm 0.3\text{ V}$  (continued)**

 over operating free-air temperature range (unless otherwise noted; see [Figure 17](#))

PARAMETER	TEST CONDITIONS	MIN	TYP	MAX	UNIT	
$t_{PHZ}$	From DIR (input) to A (output)	$V_{CCB} = 1.8\text{ V} \pm 0.15\text{ V}$	2.3		10.3	ns
		$V_{CCB} = 2.5\text{ V} \pm 0.2\text{ V}$	2.4		10.3	
		$V_{CCB} = 3.3\text{ V} \pm 0.3\text{ V}$	1.5		10.3	
		$V_{CCB} = 5\text{ V} \pm 0.5\text{ V}$	2.4		10.3	
$t_{PLZ}$	From DIR (input) to A (output)	$V_{CCB} = 1.8\text{ V} \pm 0.15\text{ V}$	1.8		8.6	ns
		$V_{CCB} = 2.5\text{ V} \pm 0.2\text{ V}$	1.6		8.6	
		$V_{CCB} = 3.3\text{ V} \pm 0.3\text{ V}$	1.9		8.7	
		$V_{CCB} = 5\text{ V} \pm 0.5\text{ V}$	2		8.7	
$t_{PHZ}$	From DIR (input) to B (output)	$V_{CCB} = 1.8\text{ V} \pm 0.15\text{ V}$	5.4		27.5	ns
		$V_{CCB} = 2.5\text{ V} \pm 0.2\text{ V}$	3.9		13.1	
		$V_{CCB} = 3.3\text{ V} \pm 0.3\text{ V}$	2.9		11.8	
		$V_{CCB} = 5\text{ V} \pm 0.5\text{ V}$	1.7		9.8	
$t_{PLZ}$	From DIR (input) to B (output)	$V_{CCB} = 1.8\text{ V} \pm 0.15\text{ V}$	2.3		17.5	ns
		$V_{CCB} = 2.5\text{ V} \pm 0.2\text{ V}$	2.1		10.8	
		$V_{CCB} = 3.3\text{ V} \pm 0.3\text{ V}$	2.4		10.1	
		$V_{CCB} = 5\text{ V} \pm 0.5\text{ V}$	1.5		7.9	
$t_{PZH}^{(1)}$	From DIR (input) to A (output)	$V_{CCB} = 1.8\text{ V} \pm 0.15\text{ V}$			28.8	ns
		$V_{CCB} = 2.5\text{ V} \pm 0.2\text{ V}$			20.2	
		$V_{CCB} = 3.3\text{ V} \pm 0.3\text{ V}$			18.9	
		$V_{CCB} = 5\text{ V} \pm 0.5\text{ V}$			16.3	
$t_{PZL}^{(1)}$	From DIR (input) to A (output)	$V_{CCB} = 1.8\text{ V} \pm 0.15\text{ V}$			37.6	ns
		$V_{CCB} = 2.5\text{ V} \pm 0.2\text{ V}$			21.5	
		$V_{CCB} = 3.3\text{ V} \pm 0.3\text{ V}$			19.8	
		$V_{CCB} = 5\text{ V} \pm 0.5\text{ V}$			17.3	
$t_{PZH}^{(1)}$	From DIR (input) to B (output)	$V_{CCB} = 1.8\text{ V} \pm 0.15\text{ V}$			27.1	ns
		$V_{CCB} = 2.5\text{ V} \pm 0.2\text{ V}$			19.6	
		$V_{CCB} = 3.3\text{ V} \pm 0.3\text{ V}$			17.5	
		$V_{CCB} = 5\text{ V} \pm 0.5\text{ V}$			16.1	
$t_{PZL}^{(1)}$	From DIR (input) to B (output)	$V_{CCB} = 1.8\text{ V} \pm 0.15\text{ V}$			25.9	ns
		$V_{CCB} = 2.5\text{ V} \pm 0.2\text{ V}$			20.3	
		$V_{CCB} = 3.3\text{ V} \pm 0.3\text{ V}$			18.3	
		$V_{CCB} = 5\text{ V} \pm 0.5\text{ V}$			17.3	

 (1) The enable time is a calculated value, derived using the formula shown in [Enable Times](#).

## 6.9 Switching Characteristics: $V_{CCA} = 5\text{ V} \pm 0.5\text{ V}$

over operating free-air temperature range (unless otherwise noted; see [Figure 17](#))

PARAMETER	TEST CONDITIONS	MIN	TYP	MAX	UNIT	
$t_{PLH}$	From A (input) to B (output)	$V_{CCB} = 1.8\text{ V} \pm 0.15\text{ V}$	1.9		18.1	ns
		$V_{CCB} = 2.5\text{ V} \pm 0.2\text{ V}$	1		10.5	
		$V_{CCB} = 3.3\text{ V} \pm 0.3\text{ V}$	0.6		8.4	
		$V_{CCB} = 5\text{ V} \pm 0.5\text{ V}$	0.5		6.9	
$t_{PHL}$	From A (input) to B (output)	$V_{CCB} = 1.8\text{ V} \pm 0.15\text{ V}$	1.8		15.2	ns
		$V_{CCB} = 2.5\text{ V} \pm 0.2\text{ V}$	0.9		9.2	
		$V_{CCB} = 3.3\text{ V} \pm 0.3\text{ V}$	0.7		7.5	
		$V_{CCB} = 5\text{ V} \pm 0.5\text{ V}$	0.5		6.5	
$t_{PLH}$	From B (input) to A (output)	$V_{CCB} = 1.8\text{ V} \pm 0.15\text{ V}$	1.4		10.2	ns
		$V_{CCB} = 2.5\text{ V} \pm 0.2\text{ V}$	1		8.1	
		$V_{CCB} = 3.3\text{ V} \pm 0.3\text{ V}$	0.7		7.4	
		$V_{CCB} = 5\text{ V} \pm 0.5\text{ V}$	0.5		6.9	
$t_{PHL}$	From B (input) to A (output)	$V_{CCB} = 1.8\text{ V} \pm 0.15\text{ V}$	1.7		10	ns
		$V_{CCB} = 2.5\text{ V} \pm 0.2\text{ V}$	0.9		7.6	
		$V_{CCB} = 3.3\text{ V} \pm 0.3\text{ V}$	0.7		7	
		$V_{CCB} = 5\text{ V} \pm 0.5\text{ V}$	0.5		6.5	
$t_{PHZ}$	From DIR (input) to A (output)	$V_{CCB} = 1.8\text{ V} \pm 0.15\text{ V}$	2.1		8.4	ns
		$V_{CCB} = 2.5\text{ V} \pm 0.2\text{ V}$	2		8.4	
		$V_{CCB} = 3.3\text{ V} \pm 0.3\text{ V}$	2.2		8.5	
		$V_{CCB} = 5\text{ V} \pm 0.5\text{ V}$	2		8.4	
$t_{PLZ}$	From DIR (input) to A (output)	$V_{CCB} = 1.8\text{ V} \pm 0.15\text{ V}$	0.9		6.8	ns
		$V_{CCB} = 2.5\text{ V} \pm 0.2\text{ V}$	1		6.8	
		$V_{CCB} = 3.3\text{ V} \pm 0.3\text{ V}$	1		6.7	
		$V_{CCB} = 5\text{ V} \pm 0.5\text{ V}$	0.9		6.7	
$t_{PHZ}$	From DIR (input) to B (output)	$V_{CCB} = 1.8\text{ V} \pm 0.15\text{ V}$	4.8		26.2	ns
		$V_{CCB} = 2.5\text{ V} \pm 0.2\text{ V}$	2.5		14.8	
		$V_{CCB} = 3.3\text{ V} \pm 0.3\text{ V}$	1		11.5	
		$V_{CCB} = 5\text{ V} \pm 0.5\text{ V}$	1.7		9.5	
$t_{PLZ}$	From DIR (input) to B (output)	$V_{CCB} = 1.8\text{ V} \pm 0.15\text{ V}$	2.6		17.8	ns
		$V_{CCB} = 2.5\text{ V} \pm 0.2\text{ V}$	2		10.4	
		$V_{CCB} = 3.3\text{ V} \pm 0.3\text{ V}$	2.5		10	
		$V_{CCB} = 5\text{ V} \pm 0.5\text{ V}$	1.6		7.5	
$t_{PZH}^{(1)}$	From DIR (input) to A (output)	$V_{CCB} = 1.8\text{ V} \pm 0.15\text{ V}$			28	ns
		$V_{CCB} = 2.5\text{ V} \pm 0.2\text{ V}$			18.5	
		$V_{CCB} = 3.3\text{ V} \pm 0.3\text{ V}$			17.4	
		$V_{CCB} = 5\text{ V} \pm 0.5\text{ V}$			14.4	
$t_{PZL}^{(1)}$	From DIR (input) to A (output)	$V_{CCB} = 1.8\text{ V} \pm 0.15\text{ V}$			36.2	ns
		$V_{CCB} = 2.5\text{ V} \pm 0.2\text{ V}$			22.4	
		$V_{CCB} = 3.3\text{ V} \pm 0.3\text{ V}$			18.5	
		$V_{CCB} = 5\text{ V} \pm 0.5\text{ V}$			16	
$t_{PZH}^{(1)}$	From DIR (input) to B (output)	$V_{CCB} = 1.8\text{ V} \pm 0.15\text{ V}$			24.9	ns
		$V_{CCB} = 2.5\text{ V} \pm 0.2\text{ V}$			17.3	
		$V_{CCB} = 3.3\text{ V} \pm 0.3\text{ V}$			15.1	
		$V_{CCB} = 5\text{ V} \pm 0.5\text{ V}$			13.6	

(1) The enable time is a calculated value, derived using the formula shown in [Enable Times](#).

**SN74LVC1T45-Q1**

SCES677D – SEPTEMBER 2006 – REVISED JULY 2017

[www.ti.com](http://www.ti.com)
**Switching Characteristics:  $V_{CCA} = 5\text{ V} \pm 0.5\text{ V}$  (continued)**

 over operating free-air temperature range (unless otherwise noted; see [Figure 17](#))

PARAMETER	TEST CONDITIONS	MIN	TYP	MAX	UNIT
$t_{PZL}^{(1)}$	From DIR (input) to B (output)			23.6	ns
		$V_{CCB} = 1.8\text{ V} \pm 0.15\text{ V}$			
		$V_{CCB} = 2.5\text{ V} \pm 0.2\text{ V}$		17.6	
		$V_{CCB} = 3.3\text{ V} \pm 0.3\text{ V}$		16	
				14.9	
	$V_{CCB} = 5\text{ V} \pm 0.5\text{ V}$				

### 6.10 Typical Characteristics

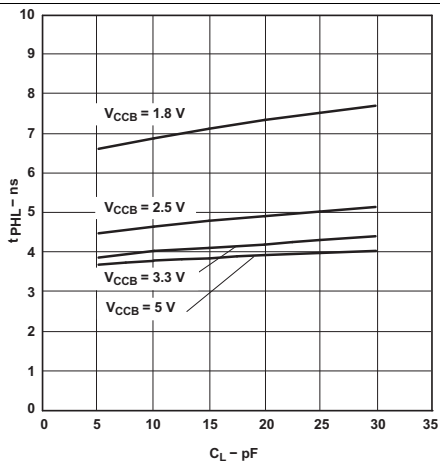

$T_A = 25^\circ\text{C}$ ,  $V_{CCA} = 1.8\text{ V}$   
**Figure 1. Typical Propagation Delay (A to B) vs Load Capacitance**

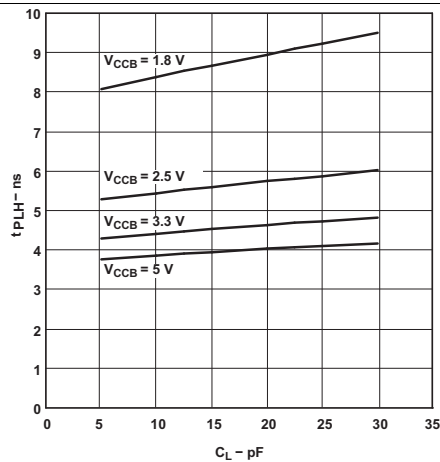

$T_A = 25^\circ\text{C}$ ,  $V_{CCA} = 1.8\text{ V}$   
**Figure 2. Typical Propagation Delay (A to B) vs Load Capacitance**

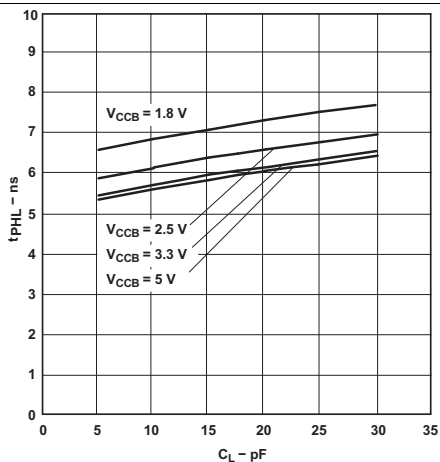

$T_A = 25^\circ\text{C}$ ,  $V_{CCA} = 1.8\text{ V}$   
**Figure 3. Typical Propagation Delay (B to A) vs Load Capacitance**

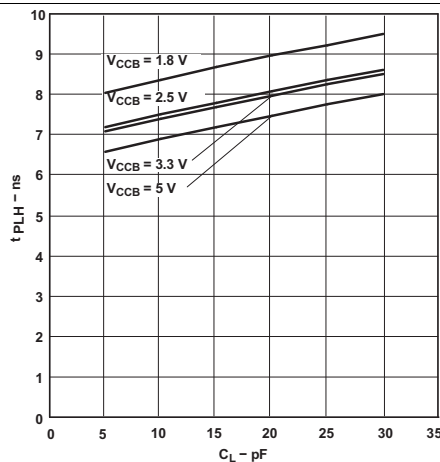

$T_A = 25^\circ\text{C}$ ,  $V_{CCA} = 1.8\text{ V}$   
**Figure 4. Typical Propagation Delay (B to A) vs Load Capacitance**

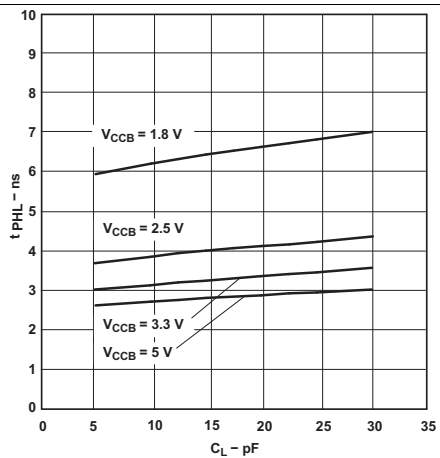

$T_A = 25^\circ\text{C}$ ,  $V_{CCA} = 2.5\text{ V}$   
**Figure 5. Typical Propagation Delay (A to B) vs Load Capacitance**

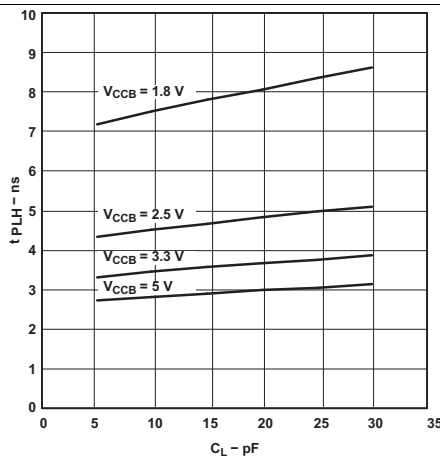

$T_A = 25^\circ\text{C}$ ,  $V_{CCA} = 2.5\text{ V}$   
**Figure 6. Typical Propagation Delay (A to B) vs Load Capacitance**

Typical Characteristics (continued)

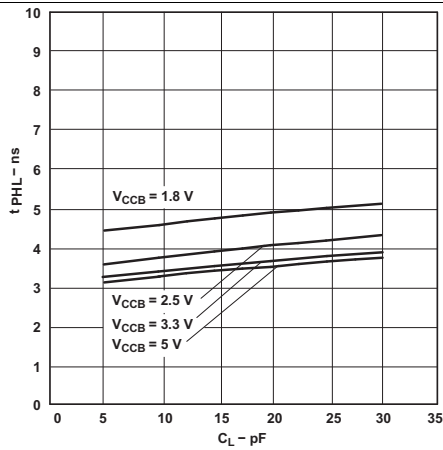

$T_A = 25^\circ\text{C}$ ,  $V_{CCA} = 2.5\text{ V}$   
**Figure 7. Typical Propagation Delay (B to A) vs Load Capacitance**

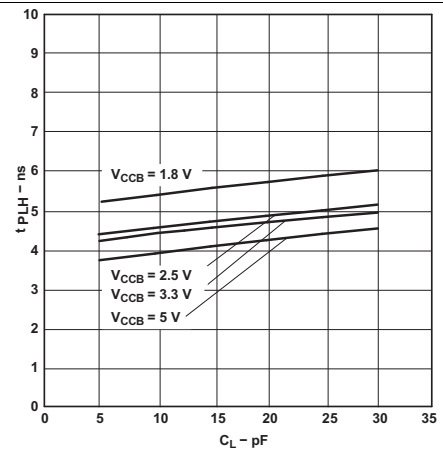

$T_A = 25^\circ\text{C}$ ,  $V_{CCA} = 2.5\text{ V}$   
**Figure 8. Typical Propagation Delay (B to A) vs Load Capacitance**

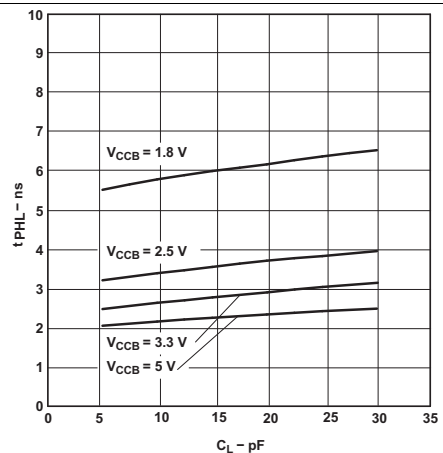

$T_A = 25^\circ\text{C}$ ,  $V_{CCA} = 3.3\text{ V}$   
**Figure 9. Typical Propagation Delay (A to B) vs Load Capacitance**

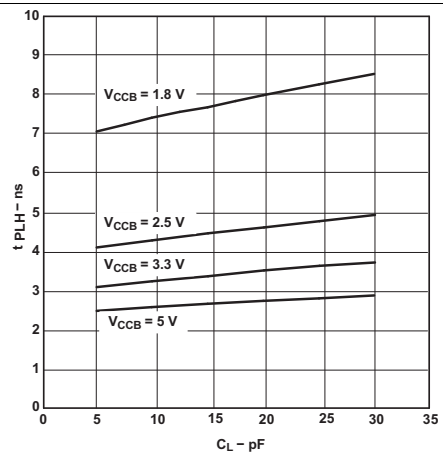

$T_A = 25^\circ\text{C}$ ,  $V_{CCA} = 3.3\text{ V}$   
**Figure 10. Typical Propagation Delay (A to B) vs Load Capacitance**

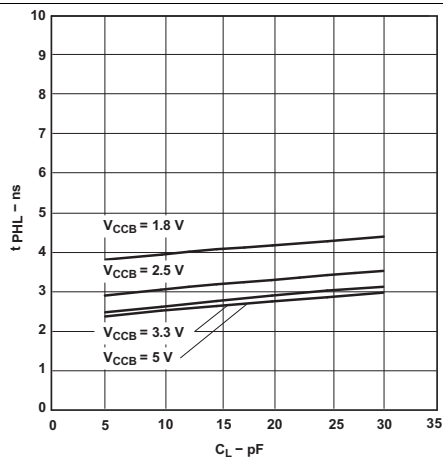

$T_A = 25^\circ\text{C}$ ,  $V_{CCA} = 3.3\text{ V}$   
**Figure 11. Typical Propagation Delay (B to A) vs Load Capacitance**

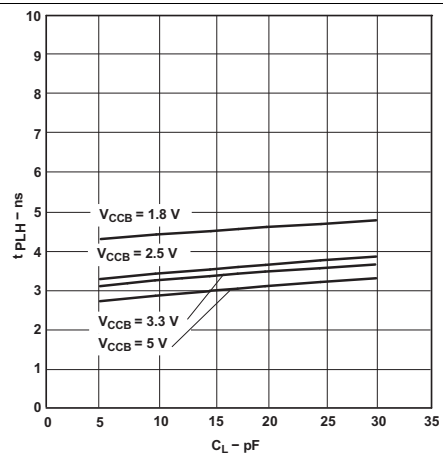

$T_A = 25^\circ\text{C}$ ,  $V_{CCA} = 3.3\text{ V}$   
**Figure 12. Typical Propagation Delay (B to A) vs Load Capacitance**

Typical Characteristics (continued)

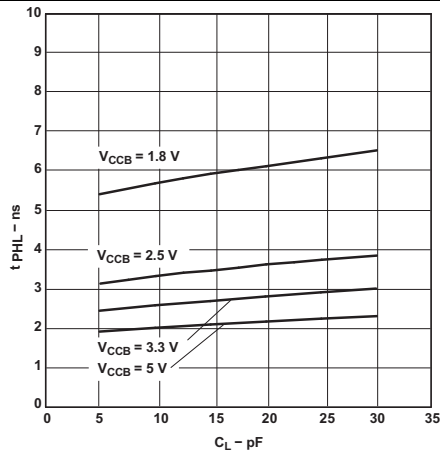

$T_A = 25^\circ\text{C}$ ,  $V_{CCA} = 5\text{ V}$   
**Figure 13. Typical Propagation Delay (A to B) vs Load Capacitance**

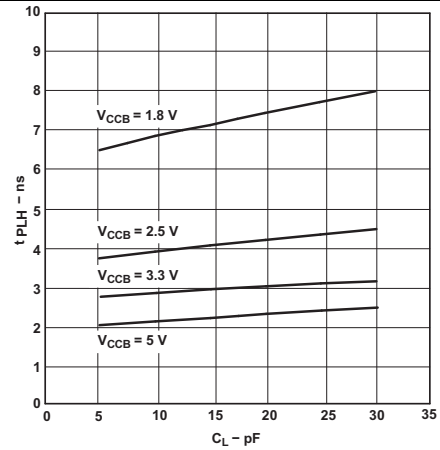

$T_A = 25^\circ\text{C}$ ,  $V_{CCA} = 5\text{ V}$   
**Figure 14. Typical Propagation Delay (A to B) vs Load Capacitance**

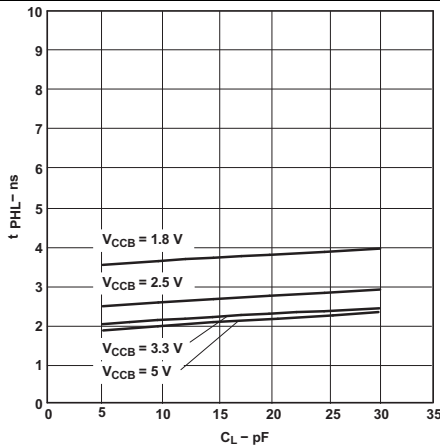

$T_A = 25^\circ\text{C}$ ,  $V_{CCA} = 5\text{ V}$   
**Figure 15. Typical Propagation Delay (B to A) vs Load Capacitance**

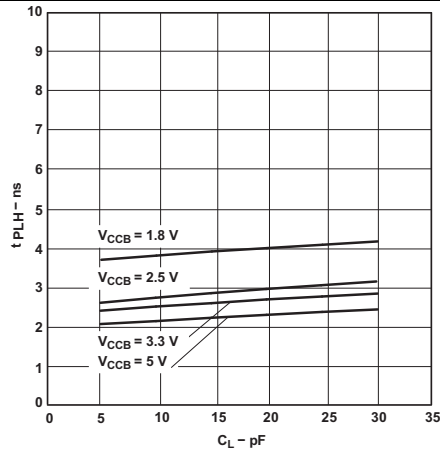

$T_A = 25^\circ\text{C}$ ,  $V_{CCA} = 5\text{ V}$   
**Figure 16. Typical Propagation Delay (B to A) vs Load Capacitance**

## 7 Parameter Measurement Information

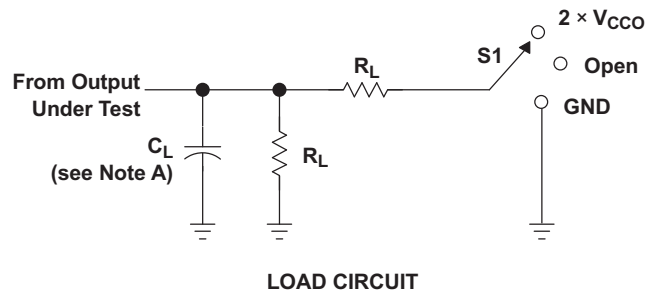

TEST	S1
$t_{pd}$	Open
$t_{PLZ}/t_{PZL}$	$2 \times V_{CCO}$
$t_{PHZ}/t_{PZH}$	GND

$V_{CCO}$	$C_L$	$R_L$	$V_{TP}$
$1.8 \text{ V} \pm 0.15 \text{ V}$	15 pF	2 k $\Omega$	0.15 V
$2.5 \text{ V} \pm 0.2 \text{ V}$	15 pF	2 k $\Omega$	0.15 V
$3.3 \text{ V} \pm 0.3 \text{ V}$	15 pF	2 k $\Omega$	0.3 V
$5 \text{ V} \pm 0.5 \text{ V}$	15 pF	2 k $\Omega$	0.3 V

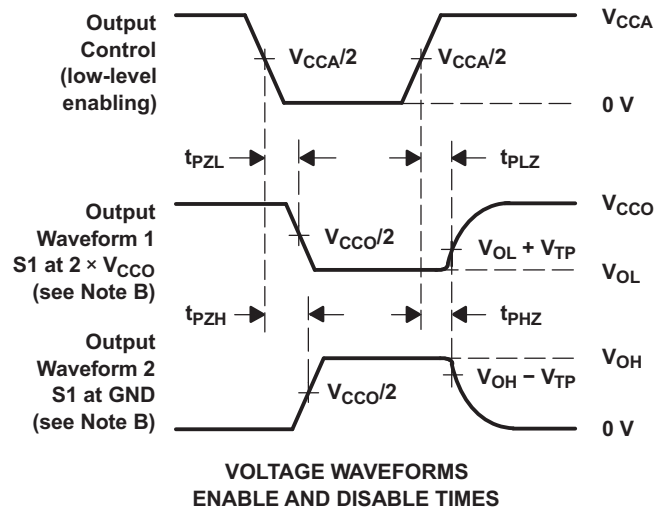
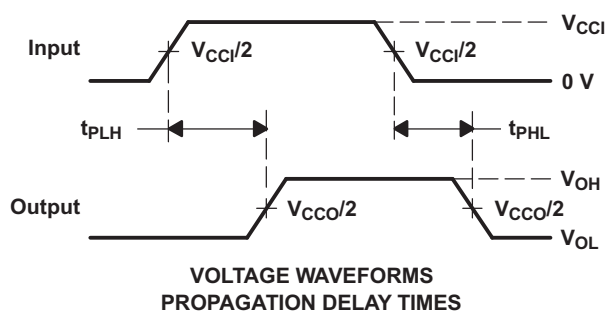
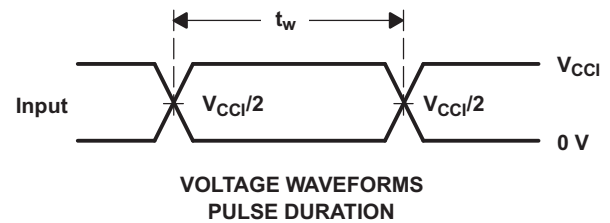

- NOTES:
- $C_L$  includes probe and jig capacitance.
  - Waveform 1 is for an output with internal conditions such that the output is low except when disabled by the output control. Waveform 2 is for an output with internal conditions such that the output is high, except when disabled by the output control.
  - All input pulses are supplied by generators having the following characteristics:  $PRR \leq 10 \text{ MHz}$ ,  $Z_O = 50 \Omega$ ,  $dv/dt \geq 1 \text{ V/ns}$ .
  - The outputs are measured one at a time, with one transition per measurement.
  - $t_{PLZ}$  and  $t_{PHZ}$  are the same as  $t_{dis}$ .
  - $t_{PZL}$  and  $t_{PZH}$  are the same as  $t_{en}$ .
  - $t_{PLH}$  and  $t_{PHL}$  are the same as  $t_{pd}$ .
  - $V_{CCI}$  is the  $V_{CC}$  associated with the input port.
  - $V_{CCO}$  is the  $V_{CC}$  associated with the output port.
  - All parameters and waveforms are not applicable to all devices.

**Figure 17. Load Circuit and Voltage Waveforms**

## 8 Detailed Description

### 8.1 Overview

The SN74LVC1T45-Q1 is single-bit, dual-supply, non-inverting voltage level translation. Pin A and that direction control pin (DIR) are supported by  $V_{CCA}$  and pin B is supported by  $V_{CCB}$ . The A port is able to accept I/O voltages ranging from 1.65 V to 5.5 V, while the B port can accept I/O voltages from 1.65 V to 5.5 V. The high on the DIR allows data transmissions from A to B and a low on the DIR allows data transmissions from B to A.

### 8.2 Functional Block Diagram

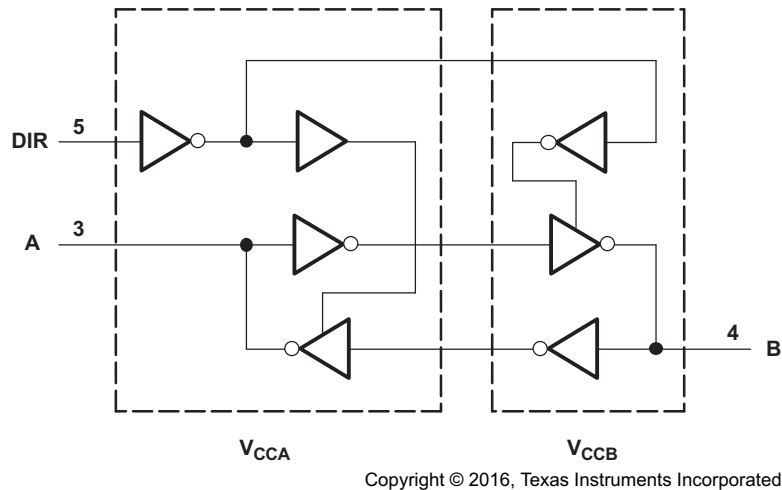

Figure 18. Logic Diagram (Positive Logic)

### 8.3 Feature Description

The SN74LVC1T45-Q1 has a fully configurable dual-rail design that allows each port to operate over the full 1.65-V to 5.5-V power-supply range. Both  $V_{CCA}$  and  $V_{CCB}$  can be supplied at any voltage between 1.65 V and 5.5 V, making the device suitable for translating between any of the voltage nodes (1.8-V, 2.5-V, 3.3-V and 5-V).

SN74LVC1T45-Q1 can support high data rate applications. The translated signal data rate can be up to 420 Mbps when the signal is translated from 3.3 V to 5 V.

$I_{off}$  prevents backflow current by disabling I/O output circuits when device is in partial-power-down mode.

### 8.4 Device Functional Modes

Table 1 lists the operational modes of SN74LVC1T45-Q1.

Table 1. Function Table<sup>(1)</sup>

INPUT DIR	OPERATION
L	B data to A bus
H	A data to B bus

(1) Input circuits of the data I/Os always are active.

## 9 Application and Implementation

### NOTE

Information in the following applications sections is not part of the TI component specification, and TI does not warrant its accuracy or completeness. TI's customers are responsible for determining suitability of components for their purposes. Customers should validate and test their design implementation to confirm system functionality.

### 9.1 Application Information

The SN74LVC1T45 device can be used in level-translation applications for interfacing devices or systems operating at different interface voltages with one another. The max data rate can be up to 420 Mbps when device translates signals from 3.3 V to 5 V.

#### 9.1.1 Enable Times

Calculate the enable times for the SN74LVC1T45-Q1 using the following formulas:

- $t_{PZH} \text{ (DIR to A)} = t_{PLZ} \text{ (DIR to B)} + t_{PLH} \text{ (B to A)}$
- $t_{PZL} \text{ (DIR to A)} = t_{PHZ} \text{ (DIR to B)} + t_{PHL} \text{ (B to A)}$
- $t_{PZH} \text{ (DIR to B)} = t_{PLZ} \text{ (DIR to A)} + t_{PLH} \text{ (A to B)}$
- $t_{PZL} \text{ (DIR to B)} = t_{PHZ} \text{ (DIR to A)} + t_{PHL} \text{ (A to B)}$

In a bidirectional application, these enable times provide the maximum delay from the time the DIR bit is switched until an output is expected. For example, if the SN74LVC1T45-Q1 initially is transmitting from A to B, then the DIR bit is switched; the B port of the device must be disabled before presenting it with an input. After the B port has been disabled, an input signal applied to it appears on the corresponding A port after the specified propagation delay.

### 9.2 Typical Applications

#### 9.2.1 Unidirectional Logic Level-Shifting Application

Figure 19 shows an example of the SN74LVC1T45-Q1 being used in a unidirectional logic level-shifting application.

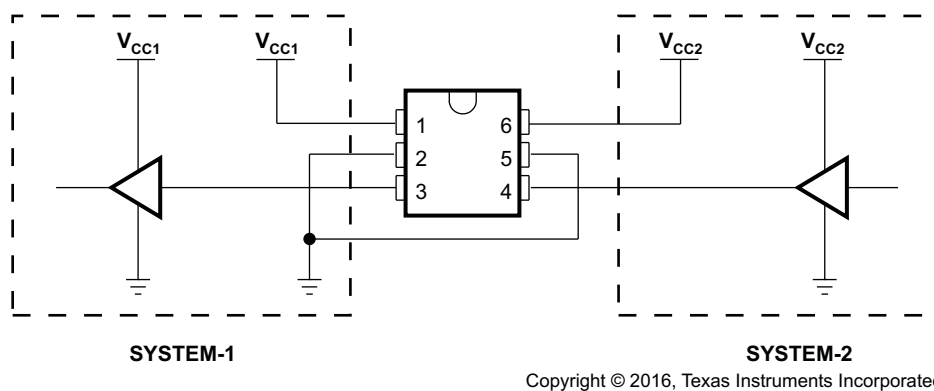

Figure 19. Unidirectional Logic Level-Shifting Application

##### 9.2.1.1 Design Requirements

For this design example, use the parameters listed in Table 2.

Table 2. Design Parameters

PARAMETER	VALUE
Input voltage	1.65 V to 5.5 V
Output voltage	1.65 V to 5.5 V

### 9.2.1.2 Detailed Design Procedure

To begin the design process, determine the following:

- Input voltage range
  - Use the supply voltage of the device that is driving the SN74LVC1T45 device to determine the input voltage range. For a valid logic high the value must exceed the  $V_{IH}$  of the input port. For a valid logic low the value must be less than the  $V_{IL}$  of the input port.
- Output voltage range
  - Use the supply voltage of the device that the SN74LVC1T45 device is driving to determine the output voltage range.

### 9.2.1.3 Application Curve

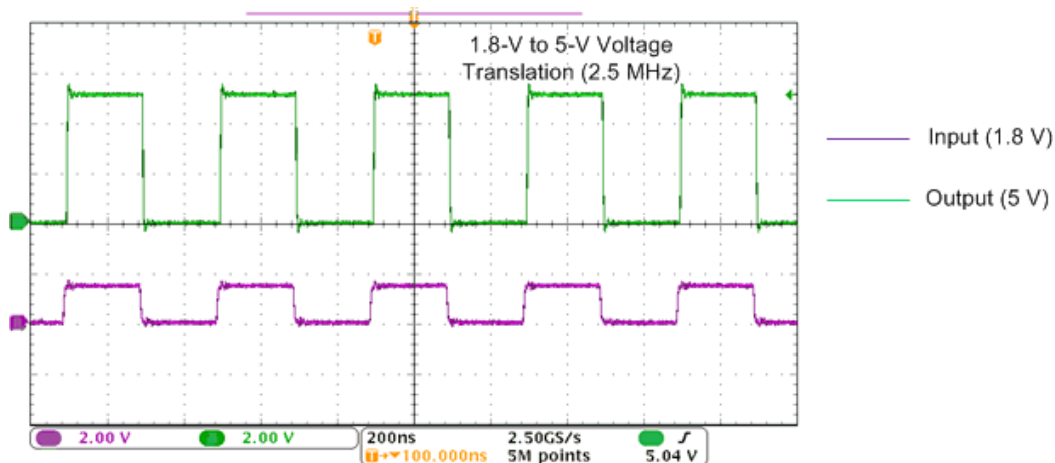

Figure 20. Translation Up (1.8 V to 5 V) at 2.5 MHz

### 9.2.2 Bidirectional Logic Level-Shifting Application

Figure 21 shows the SN74LVC1T45-Q1 being used in a bidirectional logic level-shifting application. Because the SN74LVC1T45-Q1 does not have an output-enable (OE) pin, the system designer should take precautions to avoid bus contention between SYSTEM-1 and SYSTEM-2 when changing directions.

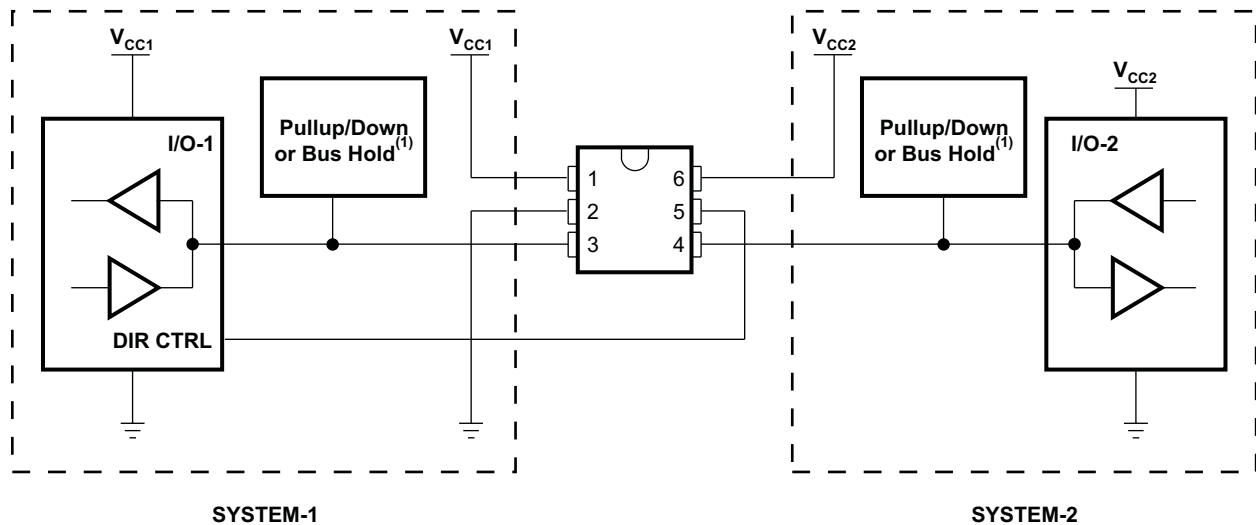

Figure 21. Bidirectional Logic Level-Shifting Application

Copyright © 2016, Texas Instruments Incorporated

9.2.2.1 Detailed Design Procedure

Table 3 shows data transmission from SYSTEM-1 to SYSTEM-2 and then from SYSTEM-2 to SYSTEM-1.

Table 3. Data Transmission

STATE	DIR CTRL	I/O-1	I/O-2	DESCRIPTION
1	H	Out	In	SYSTEM-1 data to SYSTEM-2
2	H	Hi-Z	Hi-Z	SYSTEM-2 is getting ready to send data to SYSTEM-1. I/O-1 and I/O-2 are disabled. The bus-line state depends on pullup or pulldown. <sup>(1)</sup>
3	L	Hi-Z	Hi-Z	DIR bit is flipped. I/O-1 and I/O-2 still are disabled. The bus-line state depends on pullup or pulldown. <sup>(1)</sup>
4	L	Out	In	SYSTEM-2 data to SYSTEM-1

(1) SYSTEM-1 and SYSTEM-2 must use the same conditions, that is, both pullup or both pulldown.

9.2.2.2 Application Curve

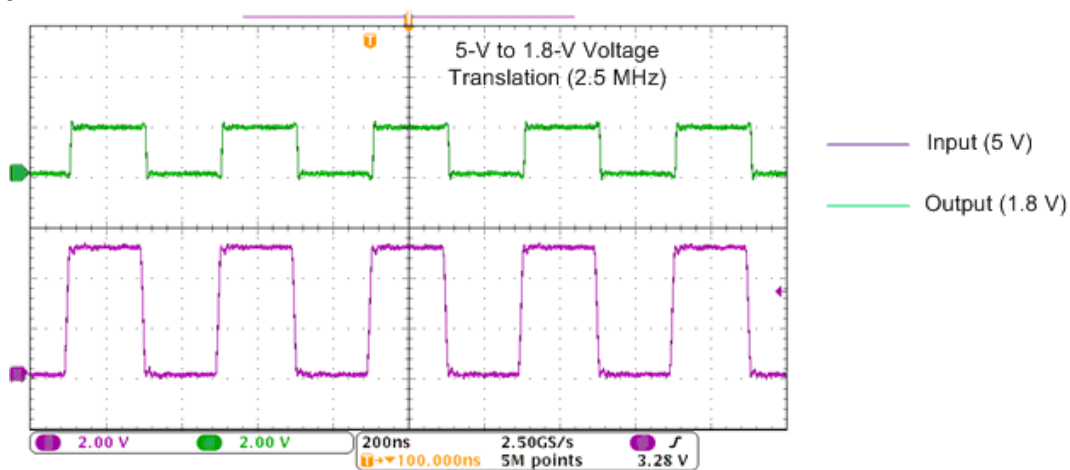

Figure 22. Translation Down (5 V to 1.8 V) at 2.5 MHz

10 Power Supply Recommendations

The SN74LVC1T45-Q1 device uses two separate configurable power-supply rails,  $V_{CCA}$  and  $V_{CCB}$ .  $V_{CCA}$  accepts any supply voltage from 1.65 V to 5.5 V, and  $V_{CCB}$  accepts any supply voltage from 1.65 V to 5.5 V. The A port and B port are designed to track  $V_{CCA}$  and  $V_{CCB}$ , respectively allowing for low-voltage bidirectional translation between any of the 1.8-V, 2.5-V, 3.3-V, and 5-V voltage nodes.

Each  $V_{CC}$  pin should have a good bypass capacitor to prevent power disturbance. For multiple  $V_{CC}$  pins then 0.01- $\mu$ F or 0.022- $\mu$ F capacitor is recommended for each power pin. It is ok to parallel multiple bypass capacitors to reject different frequencies of noise. 0.1- $\mu$ F and 1- $\mu$ F capacitors are commonly used in parallel. The bypass capacitor should be installed as close to the power pin as possible for best results.

A proper power-up sequence is advisable as listed in the following:

1. Connect ground before any supply voltage is applied.
2. Power up  $V_{CCB}$ .
3.  $V_{CCA}$  can be ramped up along with  $V_{CCB}$ .

TI recommends that the inputs are grounded during power up. Take care to assure that any state changes do not affect system level operation.

## 11 Layout

### 11.1 Layout Guidelines

To assure reliability of the device, the following common printed-circuit board layout guidelines are recommended:

- Bypass capacitors must be used on power supplies.
- Short trace lengths must be used to avoid excessive loading.
- Placing pads on the signal paths for loading capacitors or pullup resistors to help adjust rise and fall times of signals depends on the system requirements.

### 11.2 Layout Example

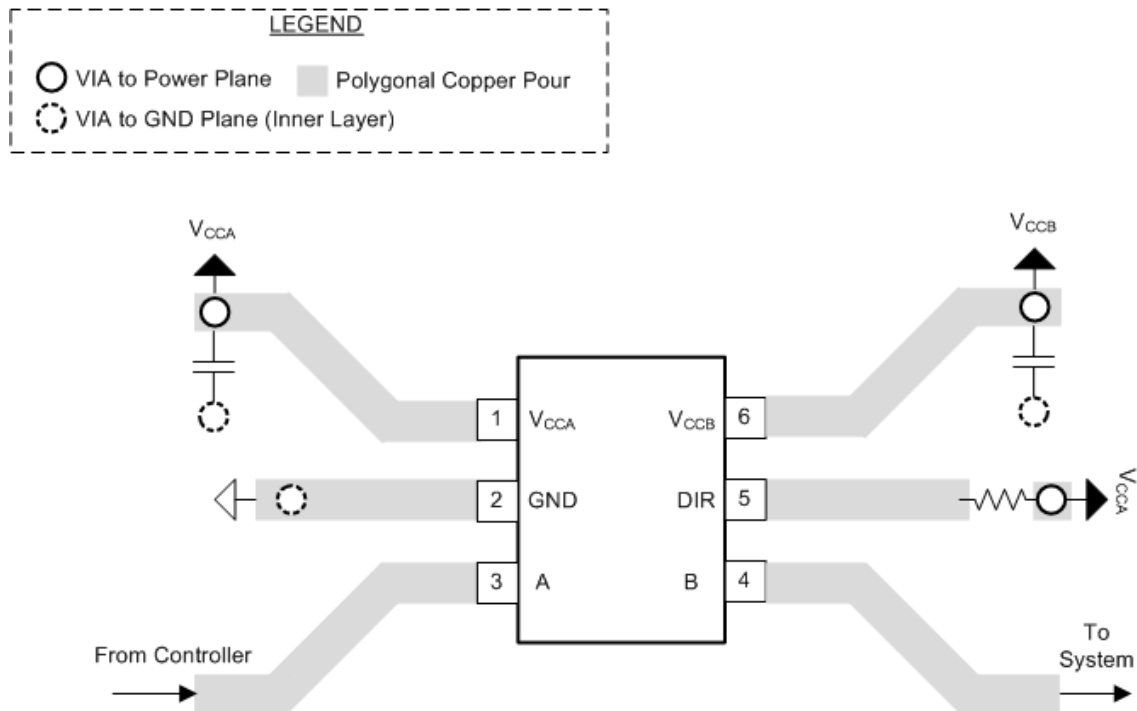

Figure 23. Layout Schematic

## 12 Device and Documentation Support

### 12.1 Documentation Support

#### 12.1.1 Related Documentation

For related documentation see the following:

[Implications of Slow or Floating CMOS Inputs](#), (SCBA004)

### 12.2 Receiving Notification of Documentation Updates

To receive notification of documentation updates, navigate to the device product folder on ti.com. In the upper right corner, click on *Alert me* to register and receive a weekly digest of any product information that has changed. For change details, review the revision history included in any revised document.

### 12.3 Community Resources

The following links connect to TI community resources. Linked contents are provided "AS IS" by the respective contributors. They do not constitute TI specifications and do not necessarily reflect TI's views; see TI's [Terms of Use](#).

**TI E2E™ Online Community** *TI's Engineer-to-Engineer (E2E) Community*. Created to foster collaboration among engineers. At e2e.ti.com, you can ask questions, share knowledge, explore ideas and help solve problems with fellow engineers.

**Design Support** *TI's Design Support* Quickly find helpful E2E forums along with design support tools and contact information for technical support.

### 12.4 Trademarks

E2E is a trademark of Texas Instruments.  
All other trademarks are the property of their respective owners.

### 12.5 Electrostatic Discharge Caution



These devices have limited built-in ESD protection. The leads should be shorted together or the device placed in conductive foam during storage or handling to prevent electrostatic damage to the MOS gates.

### 12.6 Glossary

[SLYZ022](#) — *TI Glossary*.

This glossary lists and explains terms, acronyms, and definitions.

## 13 Mechanical, Packaging, and Orderable Information

The following pages include mechanical, packaging, and orderable information. This information is the most current data available for the designated devices. This data is subject to change without notice and revision of this document. For browser-based versions of this data sheet, refer to the left-hand navigation.

**PACKAGING INFORMATION**

Orderable Device	Status (1)	Package Type	Package Drawing	Pins	Package Qty	Eco Plan (2)	Lead/Ball Finish (6)	MSL Peak Temp (3)	Op Temp (°C)	Device Marking (4/5)	Samples
SN74LVC1T45QDCKRQ1	ACTIVE	SC70	DCK	6	3000	Green (RoHS & no Sb/Br)	CU NIPDAU	Level-1-260C-UNLIM	-40 to 125	5TR	<b>Samples</b>

(1) The marketing status values are defined as follows:

**ACTIVE:** Product device recommended for new designs.

**LIFEBUY:** TI has announced that the device will be discontinued, and a lifetime-buy period is in effect.

**NRND:** Not recommended for new designs. Device is in production to support existing customers, but TI does not recommend using this part in a new design.

**PREVIEW:** Device has been announced but is not in production. Samples may or may not be available.

**OBSOLETE:** TI has discontinued the production of the device.

(2) Eco Plan - The planned eco-friendly classification: Pb-Free (RoHS), Pb-Free (RoHS Exempt), or Green (RoHS & no Sb/Br) - please check <http://www.ti.com/productcontent> for the latest availability information and additional product content details.

**TBD:** The Pb-Free/Green conversion plan has not been defined.

**Pb-Free (RoHS):** TI's terms "Lead-Free" or "Pb-Free" mean semiconductor products that are compatible with the current RoHS requirements for all 6 substances, including the requirement that lead not exceed 0.1% by weight in homogeneous materials. Where designed to be soldered at high temperatures, TI Pb-Free products are suitable for use in specified lead-free processes.

**Pb-Free (RoHS Exempt):** This component has a RoHS exemption for either 1) lead-based flip-chip solder bumps used between the die and package, or 2) lead-based die adhesive used between the die and leadframe. The component is otherwise considered Pb-Free (RoHS compatible) as defined above.

**Green (RoHS & no Sb/Br):** TI defines "Green" to mean Pb-Free (RoHS compatible), and free of Bromine (Br) and Antimony (Sb) based flame retardants (Br or Sb do not exceed 0.1% by weight in homogeneous material)

(3) MSL, Peak Temp. - The Moisture Sensitivity Level rating according to the JEDEC industry standard classifications, and peak solder temperature.

(4) There may be additional marking, which relates to the logo, the lot trace code information, or the environmental category on the device.

(5) Multiple Device Markings will be inside parentheses. Only one Device Marking contained in parentheses and separated by a "~" will appear on a device. If a line is indented then it is a continuation of the previous line and the two combined represent the entire Device Marking for that device.

(6) Lead/Ball Finish - Orderable Devices may have multiple material finish options. Finish options are separated by a vertical ruled line. Lead/Ball Finish values may wrap to two lines if the finish value exceeds the maximum column width.

**Important Information and Disclaimer:** The information provided on this page represents TI's knowledge and belief as of the date that it is provided. TI bases its knowledge and belief on information provided by third parties, and makes no representation or warranty as to the accuracy of such information. Efforts are underway to better integrate information from third parties. TI has taken and continues to take reasonable steps to provide representative and accurate information but may not have conducted destructive testing or chemical analysis on incoming materials and chemicals. TI and TI suppliers consider certain information to be proprietary, and thus CAS numbers and other limited information may not be available for release.

In no event shall TI's liability arising out of such information exceed the total purchase price of the TI part(s) at issue in this document sold by TI to Customer on an annual basis.

**OTHER QUALIFIED VERSIONS OF SN74LVC1T45-Q1 :**

- Catalog: [SN74LVC1T45](#)
- Enhanced Product: [SN74LVC1T45-EP](#)

## NOTE: Qualified Version Definitions:

- Catalog - TI's standard catalog product
- Enhanced Product - Supports Defense, Aerospace and Medical Applications

**TAPE AND REEL INFORMATION**

**QUADRANT ASSIGNMENTS FOR PIN 1 ORIENTATION IN TAPE**

\*All dimensions are nominal

Device	Package Type	Package Drawing	Pins	SPQ	Reel Diameter (mm)	Reel Width W1 (mm)	A0 (mm)	B0 (mm)	K0 (mm)	P1 (mm)	W (mm)	Pin1 Quadrant
SN74LVC1T45QDCKRQ1	SC70	DCK	6	3000	180.0	8.4	2.47	2.3	1.25	4.0	8.0	Q3

TAPE AND REEL BOX DIMENSIONS



\*All dimensions are nominal

Device	Package Type	Package Drawing	Pins	SPQ	Length (mm)	Width (mm)	Height (mm)
SN74LVC1T45QDCKRQ1	SC70	DCK	6	3000	202.0	201.0	28.0

DCK (R-PDSO-G6)

PLASTIC SMALL-OUTLINE PACKAGE



- NOTES:
- A. All linear dimensions are in millimeters.
  - B. This drawing is subject to change without notice.
  - C. Body dimensions do not include mold flash or protrusion. Mold flash and protrusion shall not exceed 0.15 per side.
  - D. Falls within JEDEC MO-203 variation AB.

DCK (R-PDSO-G6)

PLASTIC SMALL OUTLINE

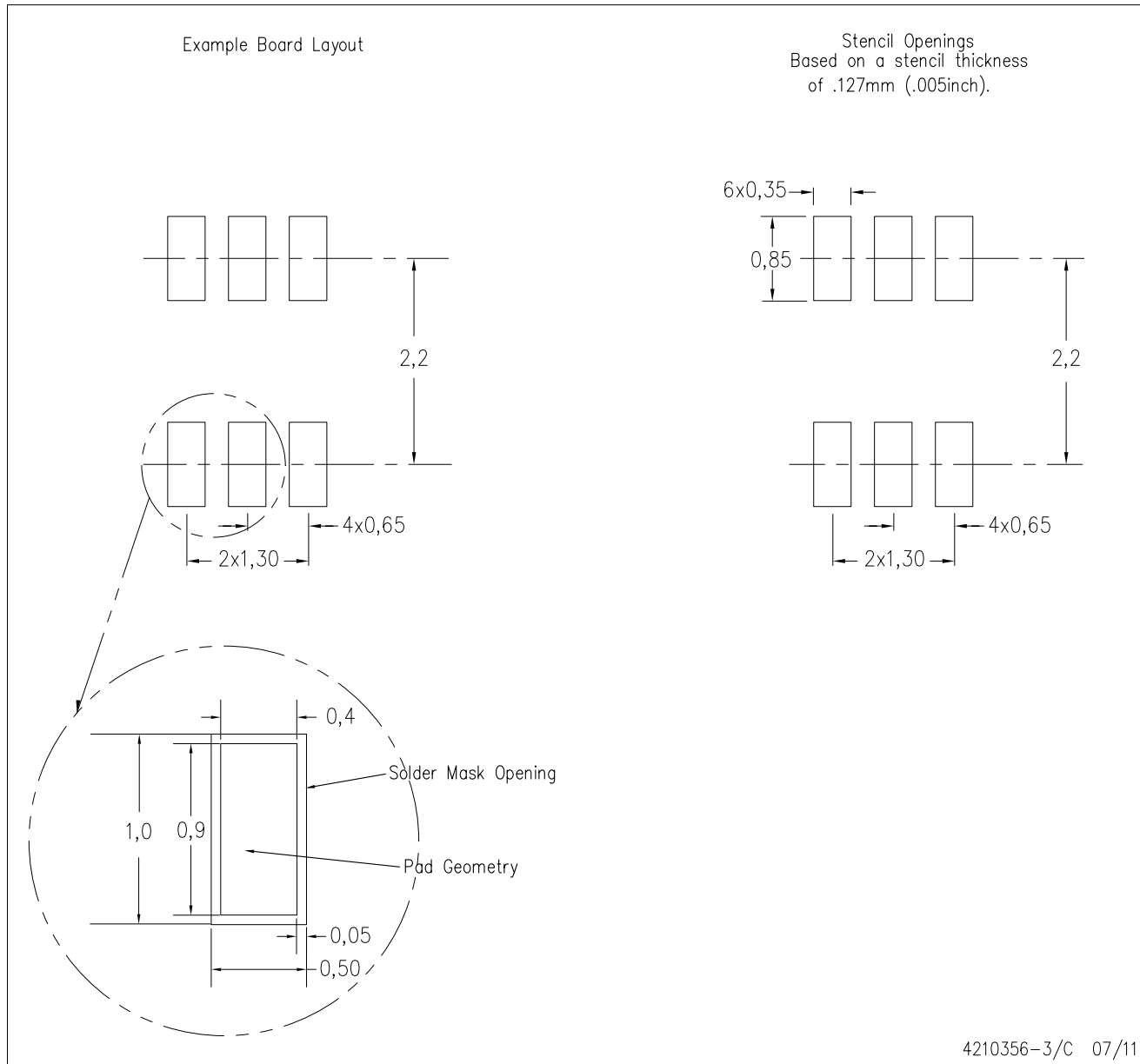

- NOTES:
- All linear dimensions are in millimeters.
  - This drawing is subject to change without notice.
  - Customers should place a note on the circuit board fabrication drawing not to alter the center solder mask defined pad.
  - Publication IPC-7351 is recommended for alternate designs.
  - Laser cutting apertures with trapezoidal walls and also rounding corners will offer better paste release. Customers should contact their board assembly site for stencil design recommendations. Example stencil design based on a 50% volumetric metal load solder paste. Refer to IPC-7525 for other stencil recommendations.

## IMPORTANT NOTICE

Texas Instruments Incorporated (TI) reserves the right to make corrections, enhancements, improvements and other changes to its semiconductor products and services per JESD46, latest issue, and to discontinue any product or service per JESD48, latest issue. Buyers should obtain the latest relevant information before placing orders and should verify that such information is current and complete.

TI's published terms of sale for semiconductor products (<http://www.ti.com/sc/docs/stdterms.htm>) apply to the sale of packaged integrated circuit products that TI has qualified and released to market. Additional terms may apply to the use or sale of other types of TI products and services.

Reproduction of significant portions of TI information in TI data sheets is permissible only if reproduction is without alteration and is accompanied by all associated warranties, conditions, limitations, and notices. TI is not responsible or liable for such reproduced documentation. Information of third parties may be subject to additional restrictions. Resale of TI products or services with statements different from or beyond the parameters stated by TI for that product or service voids all express and any implied warranties for the associated TI product or service and is an unfair and deceptive business practice. TI is not responsible or liable for any such statements.

Buyers and others who are developing systems that incorporate TI products (collectively, "Designers") understand and agree that Designers remain responsible for using their independent analysis, evaluation and judgment in designing their applications and that Designers have full and exclusive responsibility to assure the safety of Designers' applications and compliance of their applications (and of all TI products used in or for Designers' applications) with all applicable regulations, laws and other applicable requirements. Designer represents that, with respect to their applications, Designer has all the necessary expertise to create and implement safeguards that (1) anticipate dangerous consequences of failures, (2) monitor failures and their consequences, and (3) lessen the likelihood of failures that might cause harm and take appropriate actions. Designer agrees that prior to using or distributing any applications that include TI products, Designer will thoroughly test such applications and the functionality of such TI products as used in such applications.

TI's provision of technical, application or other design advice, quality characterization, reliability data or other services or information, including, but not limited to, reference designs and materials relating to evaluation modules, (collectively, "TI Resources") are intended to assist designers who are developing applications that incorporate TI products; by downloading, accessing or using TI Resources in any way, Designer (individually or, if Designer is acting on behalf of a company, Designer's company) agrees to use any particular TI Resource solely for this purpose and subject to the terms of this Notice.

TI's provision of TI Resources does not expand or otherwise alter TI's applicable published warranties or warranty disclaimers for TI products, and no additional obligations or liabilities arise from TI providing such TI Resources. TI reserves the right to make corrections, enhancements, improvements and other changes to its TI Resources. TI has not conducted any testing other than that specifically described in the published documentation for a particular TI Resource.

Designer is authorized to use, copy and modify any individual TI Resource only in connection with the development of applications that include the TI product(s) identified in such TI Resource. NO OTHER LICENSE, EXPRESS OR IMPLIED, BY ESTOPPEL OR OTHERWISE TO ANY OTHER TI INTELLECTUAL PROPERTY RIGHT, AND NO LICENSE TO ANY TECHNOLOGY OR INTELLECTUAL PROPERTY RIGHT OF TI OR ANY THIRD PARTY IS GRANTED HEREIN, including but not limited to any patent right, copyright, mask work right, or other intellectual property right relating to any combination, machine, or process in which TI products or services are used. Information regarding or referencing third-party products or services does not constitute a license to use such products or services, or a warranty or endorsement thereof. Use of TI Resources may require a license from a third party under the patents or other intellectual property of the third party, or a license from TI under the patents or other intellectual property of TI.

TI RESOURCES ARE PROVIDED "AS IS" AND WITH ALL FAULTS. TI DISCLAIMS ALL OTHER WARRANTIES OR REPRESENTATIONS, EXPRESS OR IMPLIED, REGARDING RESOURCES OR USE THEREOF, INCLUDING BUT NOT LIMITED TO ACCURACY OR COMPLETENESS, TITLE, ANY EPIDEMIC FAILURE WARRANTY AND ANY IMPLIED WARRANTIES OF MERCHANTABILITY, FITNESS FOR A PARTICULAR PURPOSE, AND NON-INFRINGEMENT OF ANY THIRD PARTY INTELLECTUAL PROPERTY RIGHTS. TI SHALL NOT BE LIABLE FOR AND SHALL NOT DEFEND OR INDEMNIFY DESIGNER AGAINST ANY CLAIM, INCLUDING BUT NOT LIMITED TO ANY INFRINGEMENT CLAIM THAT RELATES TO OR IS BASED ON ANY COMBINATION OF PRODUCTS EVEN IF DESCRIBED IN TI RESOURCES OR OTHERWISE. IN NO EVENT SHALL TI BE LIABLE FOR ANY ACTUAL, DIRECT, SPECIAL, COLLATERAL, INDIRECT, PUNITIVE, INCIDENTAL, CONSEQUENTIAL OR EXEMPLARY DAMAGES IN CONNECTION WITH OR ARISING OUT OF TI RESOURCES OR USE THEREOF, AND REGARDLESS OF WHETHER TI HAS BEEN ADVISED OF THE POSSIBILITY OF SUCH DAMAGES.

Unless TI has explicitly designated an individual product as meeting the requirements of a particular industry standard (e.g., ISO/TS 16949 and ISO 26262), TI is not responsible for any failure to meet such industry standard requirements.

Where TI specifically promotes products as facilitating functional safety or as compliant with industry functional safety standards, such products are intended to help enable customers to design and create their own applications that meet applicable functional safety standards and requirements. Using products in an application does not by itself establish any safety features in the application. Designers must ensure compliance with safety-related requirements and standards applicable to their applications. Designer may not use any TI products in life-critical medical equipment unless authorized officers of the parties have executed a special contract specifically governing such use. Life-critical medical equipment is medical equipment where failure of such equipment would cause serious bodily injury or death (e.g., life support, pacemakers, defibrillators, heart pumps, neurostimulators, and implantables). Such equipment includes, without limitation, all medical devices identified by the U.S. Food and Drug Administration as Class III devices and equivalent classifications outside the U.S.

TI may expressly designate certain products as completing a particular qualification (e.g., Q100, Military Grade, or Enhanced Product). Designers agree that it has the necessary expertise to select the product with the appropriate qualification designation for their applications and that proper product selection is at Designers' own risk. Designers are solely responsible for compliance with all legal and regulatory requirements in connection with such selection.

Designer will fully indemnify TI and its representatives against any damages, costs, losses, and/or liabilities arising out of Designer's non-compliance with the terms and provisions of this Notice.

## Looking for pricing, stock, or lifecycle information?

Click below to explore more details on WIN SOURCE:

 [View SN74LVC1T45QDCKRQ1 on WIN SOURCE](#)

 [Texas Instruments](#) Information

## Optimize Your Supply Chain with WIN SOURCE Solutions

-  Global Sourcing Solution
-  Obsolete Management
-  Cost Control Management
-  Shortage Management
-  Alternative Solution
-  Excess Inventory Management