



**THE DATASHEET OF  
TLC082QDGNRQ1**



## TLC08x-Q1 Wide-Bandwidth High-Output-Drive Single-Supply Operational Amplifiers

### 1 Features

- Wide Bandwidth: 10 MHz
- High-Output Drive
  - $I_{OH}$ : 57 mA at  $V_{DD} - 1.5$  V
  - $I_{OL}$ : 55 mA at 0.5 V
- High Slew Rate
  - $SR+$ : 16 V/ $\mu$ s
  - $SR-$ : 19 V/ $\mu$ s
- Wide Supply Range: 4.5 V to 16 V
- Supply Current: 1.9 mA per Channel
- Low Input Noise Voltage: 8.5 nV/ $\sqrt{Hz}$
- Input Offset Voltage: 60  $\mu$ V
- Ultra-Small 8-Pin MSOP-PowerPAD Package for TLC082-Q1

### 2 Applications

- Automotive
- Blind Spot Detection
- Engine Control Units
- Electric Mirrors
- HVAC
- Steering
- Collision Warnings
- Telematics
- Clusters
- Audio
- Industrial
- Instrumentations

### 3 Description

The TLC08x-Q1 is the first general purpose operational amplifier to highlight TI's BiCMOS technology. The BiMOS family concept is simple: provide an upgrade path for BiFET users who are moving away from dual-supply to single-supply systems and demand higher AC and DC performance. With performance rated from 4.5 V to 16 V across an automotive temperature range ( $-40^{\circ}C$  to  $125^{\circ}C$ ), BiMOS suits a wide range of audio, automotive, industrial, and instrumentation applications.

Developed in TI's patented LBC3 BiCMOS process, the BiMOS amplifiers combine a very high input impedance, low-noise CMOS front end with a high-drive bipolar output stage, thus providing the optimum performance features of both. AC performance improvements over the TL08x-Q1 BiFET predecessors include a bandwidth of 10 MHz and voltage noise of 8.5 nV/ $\sqrt{Hz}$ . These features enable the TLC08x-Q1 devices to be suitable for ADAS (such as short-range radar) and body in automotive. The TLC082-Q1 is also suitable in infotainment and cluster as a pre amp in car audio applications.

DC improvements include an ensured  $V_{ICR}$  that includes ground, a factor of four reduction in input offset voltage down to 1.5 mV (maximum), and a power-supply rejection improvement of greater than 40 dB to 130 dB. Added to this list of impressive features is the ability to drive  $\pm 50$ -mA loads comfortably from an ultrasmall-footprint MSOP PowerPAD™ package, which positions the TLC08x-Q1 as the ideal high-performance, general-purpose operational amplifier family.

#### Device Information<sup>(1)</sup>

PART NUMBER	PACKAGE	BODY SIZE (NOM)
TLC082-Q1	MSOP-PowerPAD (8)	3.00 mm x 3.00 mm
TLC084-Q1	HTSSOP (20)	6.50 mm x 4.40 mm

(1) For all available packages, see the orderable addendum at the end of the data sheet.

#### Operational Amplifier

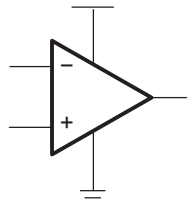



## 5 Pin Configuration and Functions

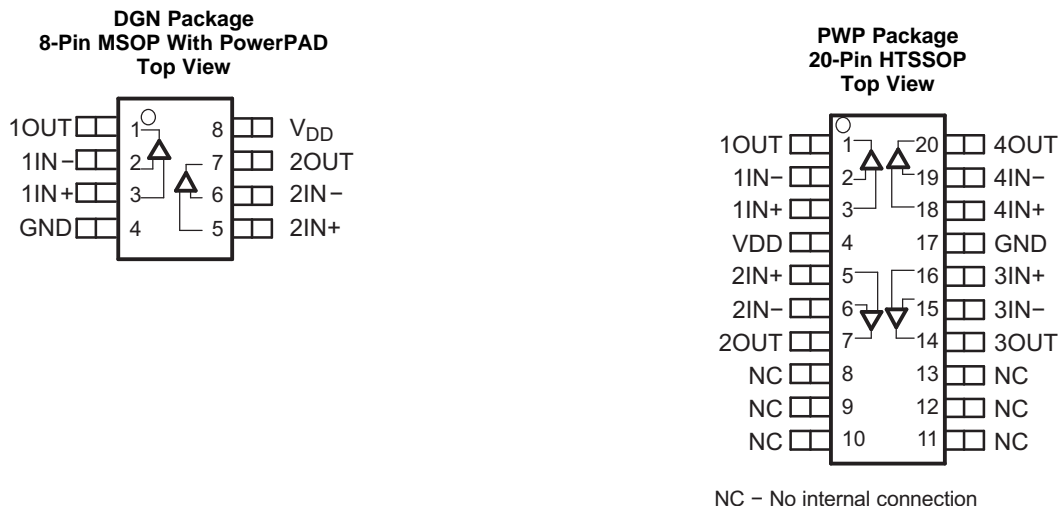

### Pin Functions

NAME	PIN		I/O	DESCRIPTION
	NO.			
	TLC082-Q1	TLC084-Q1		
1IN+	3	3	I	Noninverting input, Channel 1
1IN-	2	2	I	Inverting input, Channel 1
1OUT	1	1	O	Output, Channel 1
2IN+	5	5	I	Noninverting input, Channel 2
2IN-	6	6	I	Inverting input, Channel 2
2OUT	7	7	O	Output, Channel 2
3IN+	—	16	I	Noninverting input, Channel 3
3IN-	—	15	I	Inverting input, Channel 3
3OUT	—	14	O	Output, Channel 3
4IN+	—	18	I	Noninverting input, Channel 4
4IN-	—	19	I	Inverting input, Channel 4
4OUT	—	20	O	Output, Channel 4
GND	4	17	—	Negative (lowest) power supply
NC	—	8 to 13	—	Non-connect
VDD	8	4	I	Positive (highest) power supply

## 6 Specifications

### 6.1 Absolute Maximum Ratings

over operating free-air temperature range (unless otherwise noted)<sup>(1)</sup>

		MIN	MAX	UNIT
V <sub>DD</sub>	Supply voltage <sup>(2)</sup>	-0.3	17	V
V <sub>ID</sub>	Differential input voltage		±V <sub>DD</sub>	V
	Continuous total power dissipation	See <a href="#">Thermal Information</a>		
T <sub>J</sub>	Operating junction temperature	-40	125	°C
T <sub>A</sub>	Operating ambient temperature	-40	125	°C
T <sub>J(max)</sub>	Maximum junction temperature		150	°C
T <sub>stg</sub>	Storage temperature	-65	150	°C

- (1) Stresses beyond those listed under *Absolute Maximum Ratings* may cause permanent damage to the device. These are stress ratings only, and do not imply functional operation of the device at these or any other conditions beyond those indicated under [Recommended Operating Conditions](#). Exposure to absolute-maximum-rated conditions for extended periods may affect device reliability.
- (2) All voltage values, except differential voltages, are with respect to GND.

### 6.2 ESD Ratings

			VALUE	UNIT	
V <sub>(ESD)</sub>	Electrostatic discharge	Human-body model (HBM), per AEC Q100-002 <sup>(1)</sup>	±2000	V	
		Charged-device model (CDM), per AEC Q100-011	All pins		±500
			Corner pins (1, 4, 5, and 8)		±750

- (1) AEC Q100-002 indicates that HBM stressing shall be in accordance with the ANSI/ESDA/JEDEC JS-001 specification.

### 6.3 Recommended Operating Conditions

			MIN	MAX	UNIT
V <sub>DD</sub>	Supply voltage	Single supply	4.5	16	V
		Split supply	±2.25	±8	
V <sub>ICR</sub>	Common-mode input voltage		GND	V <sub>DD</sub> - 2	V
T <sub>J</sub>	Operating junction temperature		-40	125	°C

### 6.4 Thermal Information

THERMAL METRIC <sup>(1)</sup>		TLC082-Q1	TLC084-Q1	UNIT
		DGN (MSOP-PowerPAD)	PWP (HTSSOP)	
		8-PIN	20-PIN	
R <sub>θJA</sub>	Junction-to-ambient thermal resistance	58.1	40	°C/W
R <sub>θJC(top)</sub>	Junction-to-case (top) thermal resistance	55.2	46.7	°C/W
R <sub>θJB</sub>	Junction-to-board thermal resistance	35.3	22.9	°C/W
ψ <sub>JT</sub>	Junction-to-top characterization parameter	2.1	1	°C/W
ψ <sub>JB</sub>	Junction-to-board characterization parameter	35.9	26.7	°C/W
R <sub>θJC(bot)</sub>	Junction-to-case (bottom) thermal resistance	6.9	2.6	°C/W

- (1) For more information about traditional and new thermal metrics, see the [Semiconductor and IC Package Thermal Metrics](#) application report.

## 6.5 Electrical Characteristics: $V_{DD} = 5\text{ V}$

 $V_{DD} = 5\text{ V}$  (unless otherwise noted)

PARAMETER		TEST CONDITIONS	$T_J^{(1)}$	MIN	TYP	MAX	UNIT
$V_{IO}$	Input offset voltage	$V_{DD} = 5\text{ V}$ , $V_{IC} = 2.5\text{ V}$ , $V_O = 2.5\text{ V}$ , $R_S = 50\ \Omega$	25°C		390	1900	$\mu\text{V}$
			Full range			3300	
$\alpha_{VIO}$	Temperature coefficient of input offset voltage	$V_{DD} = 5\text{ V}$ , $V_{IC} = 2.5\text{ V}$ , $V_O = 2.5\text{ V}$ , $R_S = 50\ \Omega$			1.2		$\mu\text{V}/^\circ\text{C}$
$I_{IO}$	Input offset current	$V_{DD} = 5\text{ V}$ , $V_{IC} = 2.5\text{ V}$ , $V_O = 2.5\text{ V}$ , $R_S = 50\ \Omega$	25°C		1.9	50	$\text{pA}$
			Full range			700	
$I_{IB}$	Input bias current	$V_{DD} = 5\text{ V}$ , $V_{IC} = 2.5\text{ V}$ , $V_O = 2.5\text{ V}$ , $R_S = 50\ \Omega$	25°C		3	50	$\text{pA}$
			Full range			700	
$V_{ICR}$	Common-mode input voltage	$R_S = 50\ \Omega$	25°C	0 to 3	0 to 3.5		$\text{V}$
			Full range	0 to 3	0 to 3.5		
$V_{OH}$	High-level output voltage	$V_{IC} = 2.5\text{ V}$	$I_{OH} = -1\text{ mA}$	25°C	4.1	4.3	$\text{V}$
				Full range	3.9		
			$I_{OH} = -20\text{ mA}$	25°C	3.7	4	
				Full range	3.5		
			$I_{OH} = -35\text{ mA}$	25°C	3.4	3.8	
				Full range	3.2		
$I_{OH} = -50\text{ mA}$	25°C	3.2	3.6				
	Full range	3					
$V_{OL}$	Low-level output voltage	$V_{IC} = 2.5\text{ V}$	$I_{OL} = 1\text{ mA}$	25°C	0.18	0.25	$\text{V}$
				Full range		0.35	
			$I_{OL} = 20\text{ mA}$	25°C	0.35	0.39	
				Full range		0.45	
			$I_{OL} = 35\text{ mA}$	25°C	0.43	0.55	
				Full range		0.7	
			$I_{OL} = 50\text{ mA}$	25°C	0.45	0.63	
				Full range		0.7	
$I_{OS}$	Short-circuit output current	Sourcing	25°C		100	$\text{mA}$	
			Full range		100		
$I_O$	Output current	$V_{OH} = 1.5\text{ V}$ from positive rail	25°C		57	$\text{mA}$	
		$V_{OL} = 0.5\text{ V}$ from negative rail			55		
$A_{VD}$	Large-signal differential voltage amplification	$V_{O(PP)} = 3\text{ V}$ , $R_L = 10\text{ k}\Omega$	25°C	100	120	$\text{dB}$	
			Full range	100			
$r_{j(d)}$	Differential input resistance		25°C		1000	$\text{G}\Omega$	
$C_{IC}$	Common-mode input capacitance	$f = 10\text{ kHz}$	25°C		22.9	$\text{pF}$	
$Z_O$	Closed-loop output impedance	$f = 10\text{ kHz}$ , $A_V = 10$	25°C		0.25	$\Omega$	
CMRR	Common-mode rejection ratio	$V_{IC} = 0$ to $3\text{ V}$ , $R_S = 50\ \Omega$	25°C	70	110	$\text{dB}$	
			Full range	70			
$k_{SVR}$	Supply voltage rejection ratio ( $\Delta V_{DD} / \Delta V_{IO}$ )	$V_{DD} = 4.5\text{ V}$ to $16\text{ V}$ , $V_{IC} = V_{DD}/2$ , No load	25°C	80	100	$\text{dB}$	
			Full range	80			
$I_{DD}$	Supply current (per channel)	$V_O = 2.5\text{ V}$ , No load	25°C		1.8	2.5	$\text{mA}$
			Full range			3.5	

(1) Full range is  $-40^\circ\text{C}$  to  $125^\circ\text{C}$ .

## 6.6 Electrical Characteristics: $V_{DD} = 12\text{ V}$

 $V_{DD} = 12\text{ V}$  (unless otherwise noted)

PARAMETER		TEST CONDITIONS	$T_J$ <sup>(1)</sup>	MIN	TYP	MAX	UNIT	
$V_{IO}$	Input offset voltage	$V_{DD} = 12\text{ V}$ , $V_{IC} = 6\text{ V}$ , $V_O = 6\text{ V}$ , $R_S = 50\ \Omega$	25°C		390	1900	$\mu\text{V}$	
			Full range			3300		
$\alpha_{VIO}$	Temperature coefficient of input offset voltage	$V_{DD} = 12\text{ V}$ , $V_{IC} = 6\text{ V}$ , $V_O = 6\text{ V}$ , $R_S = 50\ \Omega$			1.2		$\mu\text{V}/^\circ\text{C}$	
$I_{IO}$	Input offset current	$V_{DD} = 12\text{ V}$ , $V_{IC} = 6\text{ V}$ , $V_O = 6\text{ V}$ , $R_S = 50\ \Omega$	25°C		1.5	50	$\mu\text{A}$	
			Full range			700		
$I_{IB}$	Input bias current	$V_{DD} = 12\text{ V}$ , $V_{IC} = 6\text{ V}$ , $V_O = 6\text{ V}$ , $R_S = 50\ \Omega$	25°C		3	50	$\mu\text{A}$	
			Full range			700		
$V_{ICR}$	Common-mode input voltage	$R_S = 50\ \Omega$	25°C	0 to 10	0 to 10.5		V	
			Full range	0 to 10	0 to 10.5			
$V_{OH}$	High-level output voltage	$V_{IC} = 6\text{ V}$	$I_{OH} = -1\text{ mA}$	25°C	11.1	11.2	V	
				Full range		11		
			$I_{OH} = -20\text{ mA}$	25°C	10.8	11		
				Full range		10.7		
			$I_{OH} = -35\text{ mA}$	25°C	10.6	10.7		
				Full range		10.3		
$I_{OH} = -50\text{ mA}$	25°C	10.3	10.5					
	Full range		10.1					
$V_{OL}$	Low-level output voltage	$V_{IC} = 6\text{ V}$	$I_{OL} = 1\text{ mA}$	25°C		0.17	0.25	V
				Full range				
			$I_{OL} = 20\text{ mA}$	25°C		0.35	0.45	
				Full range			0.55	
			$I_{OL} = 35\text{ mA}$	25°C		0.4	0.52	
				Full range			0.6	
			$I_{OL} = 50\text{ mA}$	25°C		0.45	0.6	
				Full range			0.7	
$I_{OS}$	Short-circuit output current	Sourcing	25°C		150		mA	
				Sinking		150		
$I_O$	Output current	$V_{OH} = 1.5\text{ V}$ from positive rail	25°C		57		mA	
		$V_{OL} = 0.5\text{ V}$ from negative rail			55			
$A_{VD}$	Large-signal differential voltage amplification	$V_{O(PP)} = 8\text{ V}$ , $R_L = 10\text{ k}\Omega$	25°C	110	130		dB	
			Full range		110			
$r_{j(d)}$	Differential input resistance		25°C		1000		$\text{G}\Omega$	
$C_{IC}$	Common-mode input capacitance	$f = 10\text{ kHz}$	25°C		21.6		pF	
$Z_O$	Closed-loop output impedance	$f = 10\text{ kHz}$ , $A_V = 10$	25°C		0.25		$\Omega$	
CMRR	Common-mode rejection ratio	$V_{IC} = 0$ to $10\text{ V}$ , $R_S = 50\ \Omega$	25°C	80	110		dB	
			Full range		80			
$k_{SVR}$	Supply voltage rejection ratio ( $\Delta V_{DD} / \Delta V_{IO}$ )	$V_{DD} = 4.5\text{ V}$ to $16\text{ V}$ , $V_{IC} = V_{DD} / 2$ , No load	25°C	80	100		dB	
			Full range		80			
$I_{DD}$	Supply current (per channel)	$V_O = 7.5\text{ V}$ , No load	25°C		1.9	2.9	mA	
			Full range			3.5		

 (1) Full range is  $-40^\circ\text{C}$  to  $125^\circ\text{C}$ .

## 6.7 Operating Characteristics: $V_{DD} = 5\text{ V}$

 $V_{DD} = 5\text{ V}$  (unless otherwise noted)

PARAMETER		TEST CONDITIONS		$T_J^{(1)}$	MIN	TYP	MAX	UNIT
SR+	Positive slew rate at unity gain	$V_{O(PP)} = 0.8\text{ V}$ , $C_L = 50\text{ pF}$ , $R_L = 10\text{ k}\Omega$		25°C	10	16		V/ $\mu\text{s}$
				Full range	9			
SR–	Negative slew rate at unity gain	$V_{O(PP)} = 0.8\text{ V}$ , $C_L = 50\text{ pF}$ , $R_L = 10\text{ k}\Omega$		25°C	11	19		V/ $\mu\text{s}$
				Full range	8.5			
$V_n$	Equivalent input noise voltage	$f = 100\text{ Hz}$ $f = 1\text{ kHz}$		25°C	12			nV/ $\sqrt{\text{Hz}}$
					8.5			
$I_n$	Equivalent input noise current	$f = 1\text{ kHz}$		25°C	0.6			fA/ $\sqrt{\text{Hz}}$
THD+N	Total harmonic distortion plus noise	$V_{O(PP)} = 3\text{ V}$ , $R_L = 10\text{ k}\Omega$ and $250\ \Omega$ , $f = 1\text{ kHz}$		25°C	$A_V = 1$	0.002%		—
					$A_V = 10$	0.012%		
					$A_V = 100$	0.085%		
Gain-bandwidth product		$f = 10\text{ kHz}$ , $R_L = 10\text{ k}\Omega$		25°C	10			MHz
$t_s$	Settling time	$V_{(STEP)PP} = 1\text{ V}$ , $A_V = -1$ , $C_L = 10\text{ pF}$ , $R_L = 10\text{ k}\Omega$		25°C	0.1%	0.18		$\mu\text{s}$
					0.01%	0.39		
		$V_{(STEP)PP} = 1\text{ V}$ , $A_V = -1$ , $C_L = 47\text{ pF}$ , $R_L = 10\text{ k}\Omega$			0.1%	0.18		
					0.01%	0.39		
$\phi_m$	Phase margin	$R_L = 10\text{ k}\Omega$		25°C	$C_L = 50\text{ pF}$	32		°
					$C_L = 0\text{ pF}$	40		
	Gain margin	$R_L = 10\text{ k}\Omega$		25°C	$C_L = 50\text{ pF}$	2.2		dB
					$C_L = 0\text{ pF}$	3.3		

 (1) Full range is  $-40^\circ\text{C}$  to  $125^\circ\text{C}$ .

## 6.8 Operating Characteristics: $V_{DD} = 12\text{ V}$

 $V_{DD} = 12\text{ V}$  (unless otherwise noted)

PARAMETER		TEST CONDITIONS		$T_J^{(1)}$	MIN	TYP	MAX	UNIT
SR+	Positive slew rate at unity gain	$V_{O(PP)} = 2\text{ V}$ , $C_L = 50\text{ pF}$ , $R_L = 10\text{ k}\Omega$		25°C	10	16		V/ $\mu\text{s}$
				Full range	9.5			
SR–	Negative slew rate at unity gain	$V_{O(PP)} = 2\text{ V}$ , $C_L = 50\text{ pF}$ , $R_L = 10\text{ k}\Omega$		25°C	12.5	19		V/ $\mu\text{s}$
				Full range	10			
$V_n$	Equivalent input noise voltage	$f = 100\text{ Hz}$ $f = 1\text{ kHz}$		25°C	14			nV/ $\sqrt{\text{Hz}}$
					8.5			
$I_n$	Equivalent input noise current	$f = 1\text{ kHz}$		25°C	0.6			fA/ $\sqrt{\text{Hz}}$
THD+N	Total harmonic distortion plus noise	$V_{O(PP)} = 8\text{ V}$ , $R_L = 10\text{ k}\Omega$ and $250\ \Omega$ , $f = 1\text{ kHz}$		25°C	$A_V = 1$	0.002%		—
					$A_V = 10$	0.005%		
					$A_V = 100$	0.022%		
Gain-bandwidth product		$f = 10\text{ kHz}$ , $R_L = 10\text{ k}\Omega$		25°C	10			MHz
$t_s$	Settling time	$V_{(STEP)PP} = 1\text{ V}$ , $A_V = -1$ , $C_L = 10\text{ pF}$ , $R_L = 10\text{ k}\Omega$		25°C	0.1%	0.17		$\mu\text{s}$
					0.01%	0.22		
		$V_{(STEP)PP} = 1\text{ V}$ , $A_V = -1$ , $C_L = 47\text{ pF}$ , $R_L = 10\text{ k}\Omega$			0.1%	0.17		
					0.01%	0.29		
$\phi_m$	Phase margin	$R_L = 10\text{ k}\Omega$		25°C	$C_L = 50\text{ pF}$	37		deg
					$C_L = 0\text{ pF}$	42		
	Gain margin	$R_L = 10\text{ k}\Omega$		25°C	$C_L = 50\text{ pF}$	3.1		dB
					$C_L = 0\text{ pF}$	4		

 (1) Full range is  $-40^\circ\text{C}$  to  $125^\circ\text{C}$ .

## 6.9 Typical Characteristics

**Table 1. Table of Graphs**

GRAPH NAME			FIGURE NO.
$V_{IO}$	Input offset voltage	vs Common-mode input voltage	<a href="#">Figure 1</a> , <a href="#">Figure 2</a>
$I_{IO}$	Input offset current	vs Free-air temperature	<a href="#">Figure 3</a>
$I_{IB}$	Input bias current	vs Free-air temperature	<a href="#">Figure 4</a>
$V_{OH}$	High-level output voltage	vs High-level output current	<a href="#">Figure 5</a> , <a href="#">Figure 7</a>
$V_{OL}$	Low-level output voltage	vs Low-level output current	<a href="#">Figure 6</a> , <a href="#">Figure 8</a>
$Z_O$	Output impedance	vs Frequency	<a href="#">Figure 9</a>
$I_{DD}$	Supply current	vs Supply voltage	<a href="#">Figure 10</a>
PSRR	Power supply rejection ratio	vs Frequency	<a href="#">Figure 11</a>
CMRR	Common-mode rejection ratio	vs Frequency	<a href="#">Figure 12</a>
$V_n$	Equivalent input noise voltage	vs Frequency	<a href="#">Figure 13</a>
$V_{O(PP)}$	Peak-to-peak output voltage	vs Frequency	<a href="#">Figure 14</a> , <a href="#">Figure 15</a>
	Crosstalk	vs Frequency	<a href="#">Figure 16</a>
	Differential voltage gain and Phase	vs Frequency	<a href="#">Figure 17</a> , <a href="#">Figure 18</a>
$\phi_m$	Phase margin	vs Load capacitance	<a href="#">Figure 19</a> , <a href="#">Figure 20</a>
	Gain margin	vs Load capacitance	<a href="#">Figure 21</a> , <a href="#">Figure 22</a>
	Gain-bandwidth product	vs Supply voltage	<a href="#">Figure 23</a>
SR	Slew rate	vs Supply voltage	<a href="#">Figure 24</a>
		vs Free-air temperature	<a href="#">Figure 25</a> , <a href="#">Figure 26</a>
THD+N	Total harmonic distortion plus noise	vs Frequency	<a href="#">Figure 27</a> , <a href="#">Figure 28</a>
		vs Peak-to-peak output voltage	<a href="#">Figure 29</a> , <a href="#">Figure 30</a>
	Large-signal follower pulse response		<a href="#">Figure 31</a> , <a href="#">Figure 32</a>
	Small-signal follower pulse response		<a href="#">Figure 33</a>
	Large-signal inverting pulse response		<a href="#">Figure 34</a> , <a href="#">Figure 34</a>
	Small-signal inverting pulse response		<a href="#">Figure 36</a>

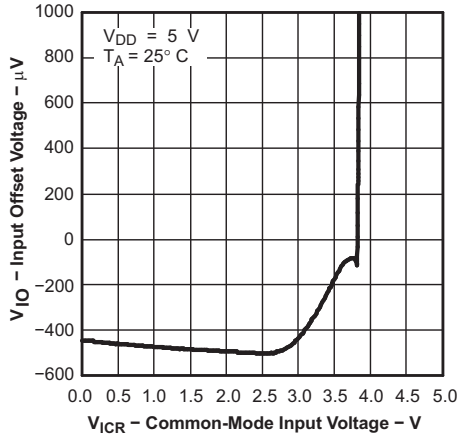

Figure 1. Input Offset Voltage vs Common-Mode Input Voltage

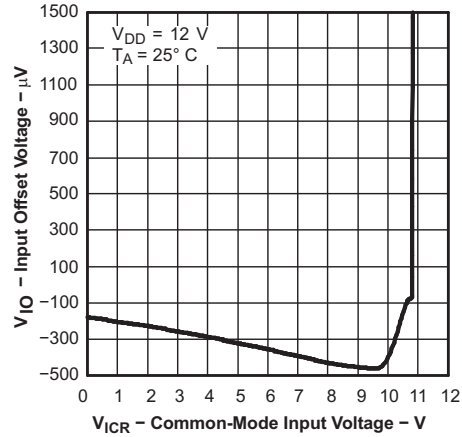

Figure 2. Input Offset Voltage vs Common-Mode Input Voltage

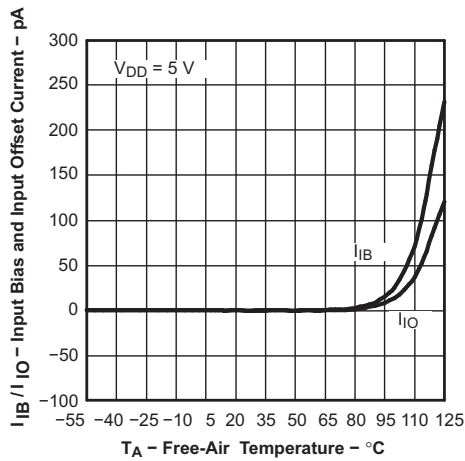

Figure 3. Input Bias Current and Input Offset Current vs Free-Air Temperature

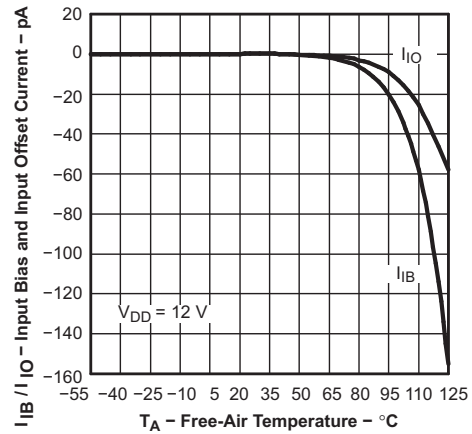

Figure 4. Input Bias Current and Input Offset Current vs Free-Air Temperature

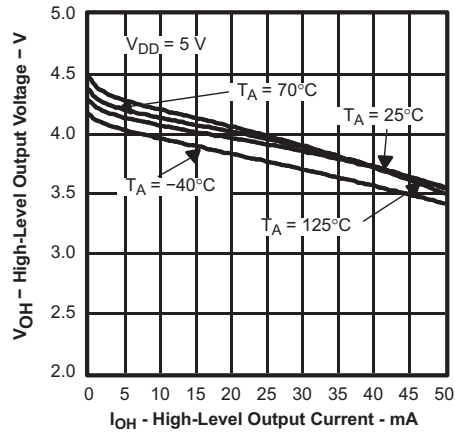

Figure 5. High-Level Output Voltage vs High-Level Output Current

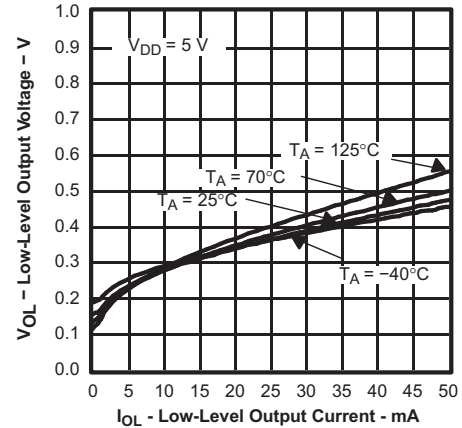

Figure 6. Low-Level Output Voltage vs Low-Level Output Current

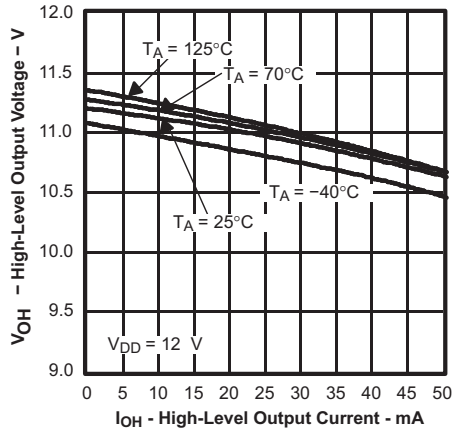

Figure 7. High-Level Output Voltage vs High-Level Output Current

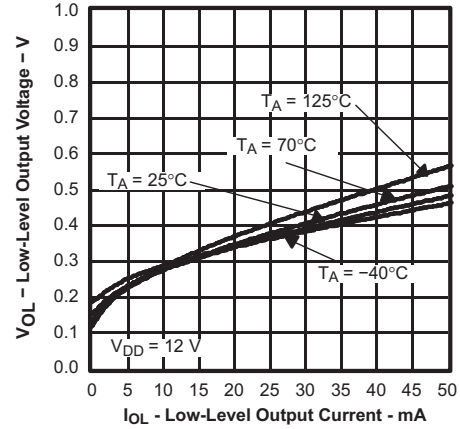

Figure 8. Low-Level Output Voltage vs Low-Level Output Current

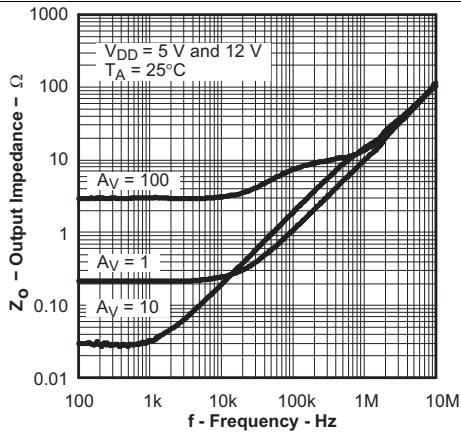

Figure 9. Output Impedance vs Frequency

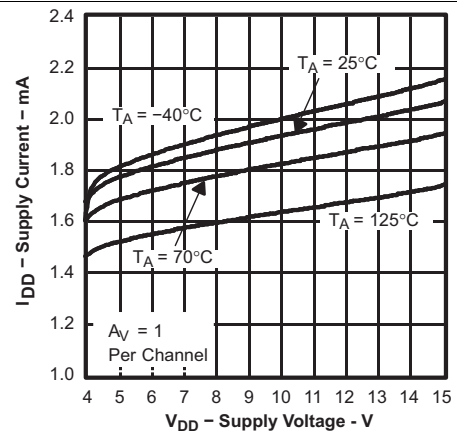

Figure 10. Supply Current vs Supply Voltage

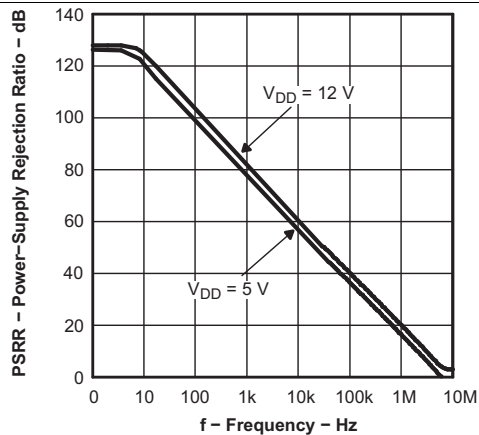

Figure 11. Power-Supply Rejection Ratio vs Frequency

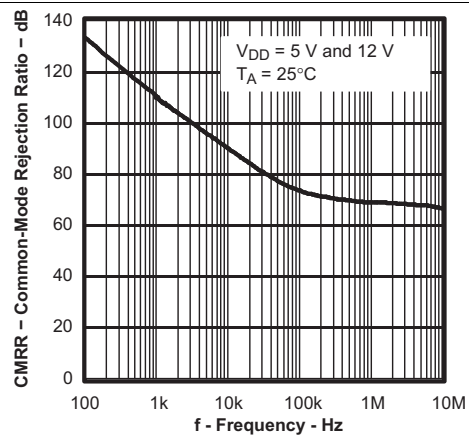

Figure 12. Common-Mode Rejection Ratio vs Frequency

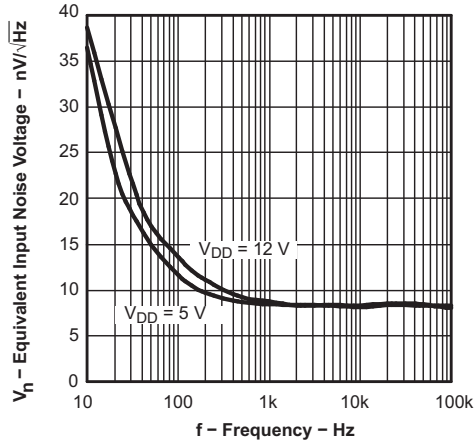

Figure 13. Equivalent Input Noise Voltage vs Frequency

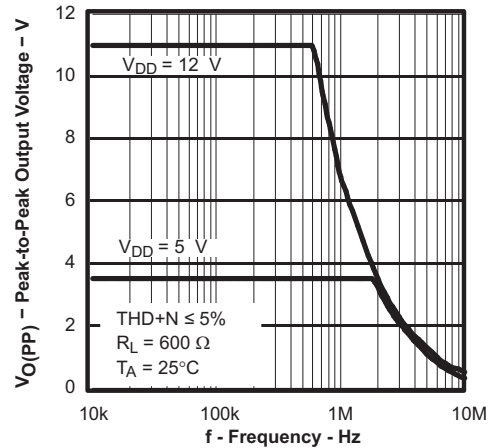

Figure 14. Peak-to-Peak Output Voltage vs Frequency

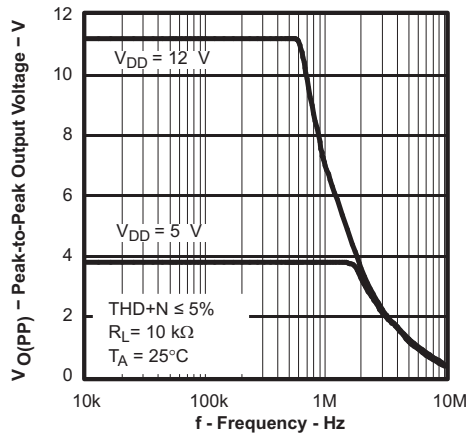

Figure 15. Peak-to-Peak Output Voltage vs Frequency

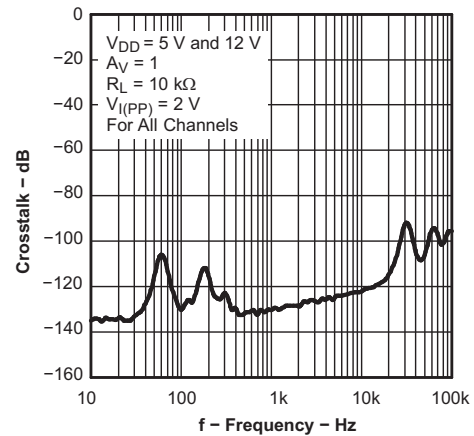

Figure 16. Crosstalk vs Frequency

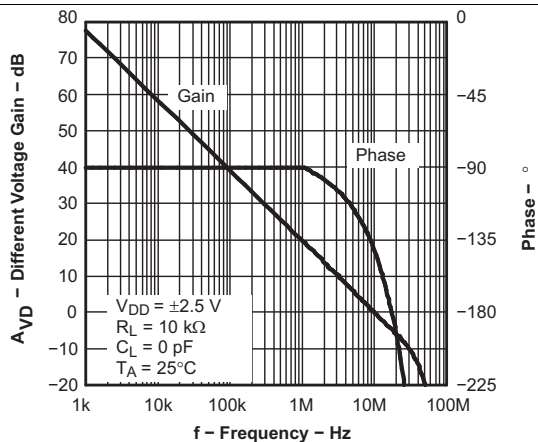

Figure 17. Differential Voltage Gain and Phase vs Frequency

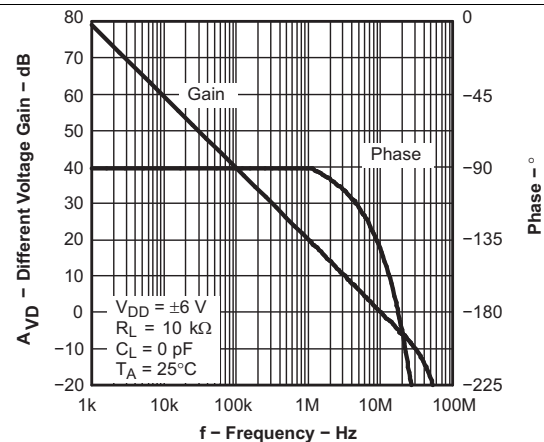

Figure 18. Differential Voltage Gain and Phase vs Frequency

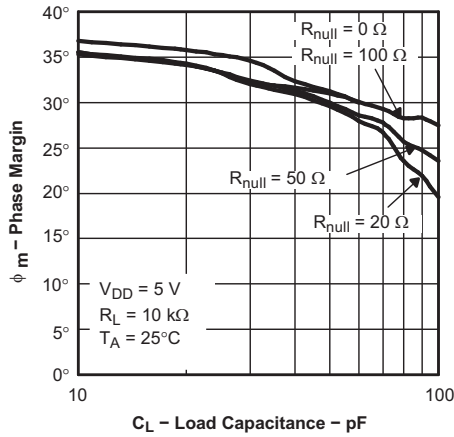

Figure 19. Phase Margin vs Load Capacitance

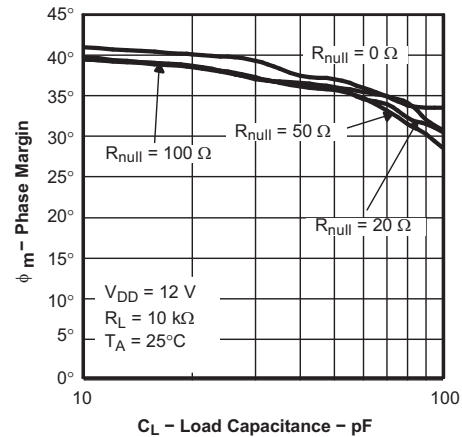

Figure 20. Phase Margin vs Load Capacitance

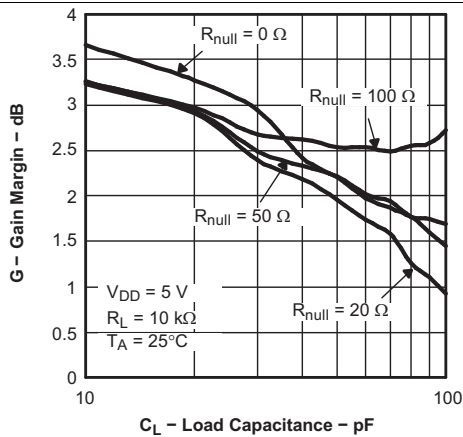

Figure 21. Gain Margin vs Load Capacitance

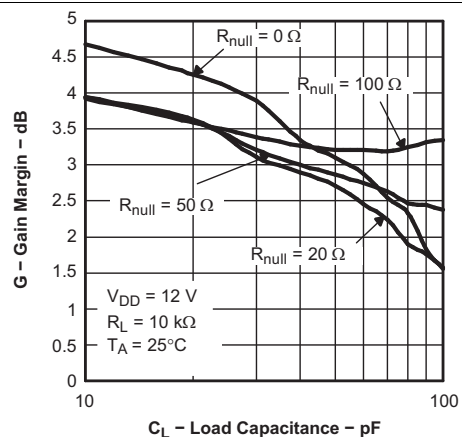

Figure 22. Gain Margin vs Load Capacitance

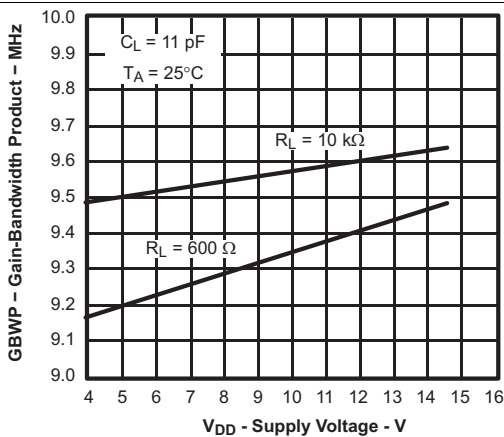

Figure 23. Gain-Bandwidth Product vs Supply Voltage

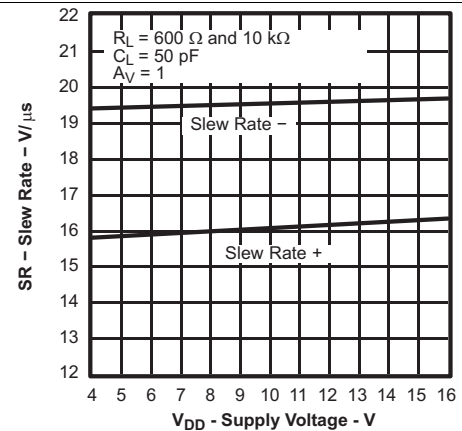

Figure 24. Slew Rate vs Supply Voltage

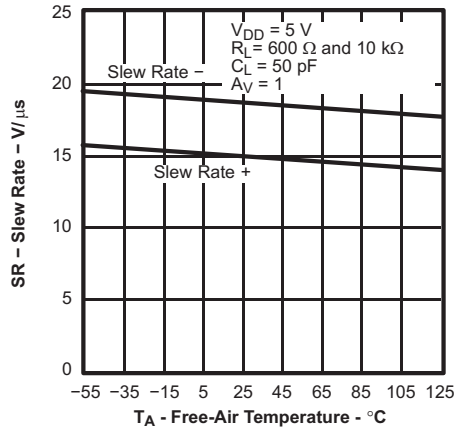

Figure 25. Slew Rate vs Free-Air Temperature

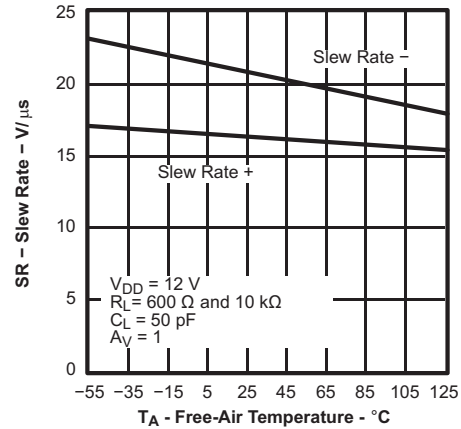

Figure 26. Slew Rate vs Free-Air Temperature

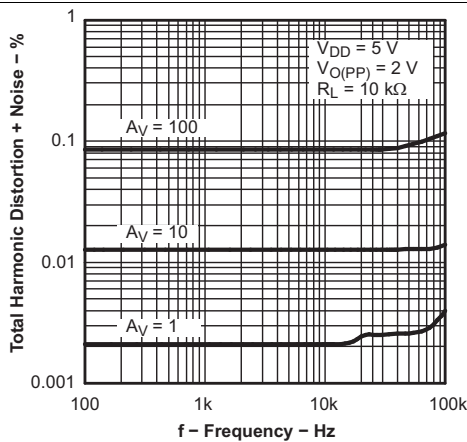

Figure 27. Total Harmonic Distortion + Noise vs Frequency

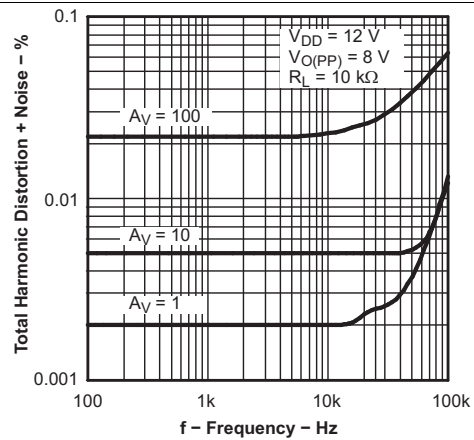

Figure 28. Total Harmonic Distortion + Noise vs Frequency

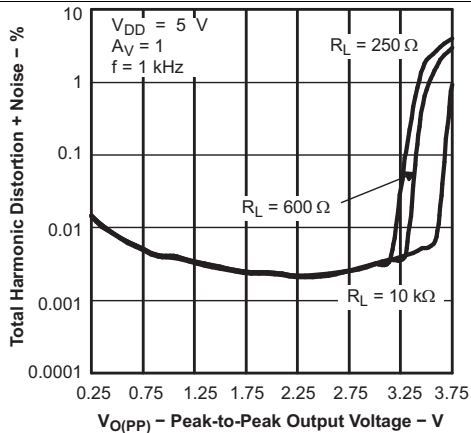

Figure 29. Total Harmonic Distortion Plus Peak-to-Peak Output Voltage

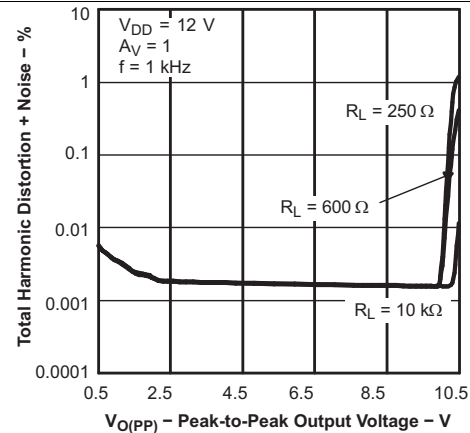

Figure 30. Total Harmonic Distortion Plus Peak-to-Peak Output Voltage

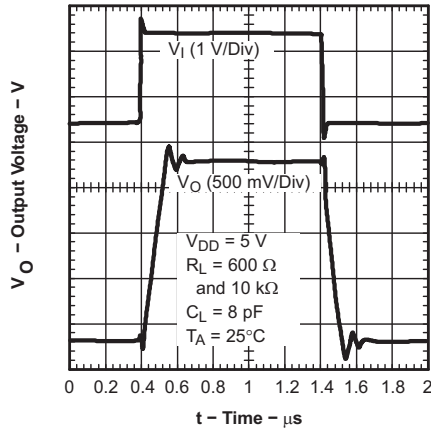

Figure 31. Large-Signal Follower Pulse Response

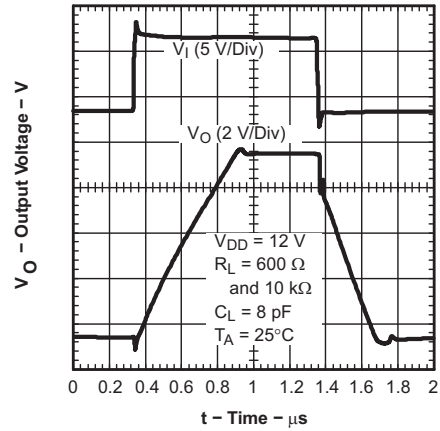

Figure 32. Large-Signal Follower Pulse Response

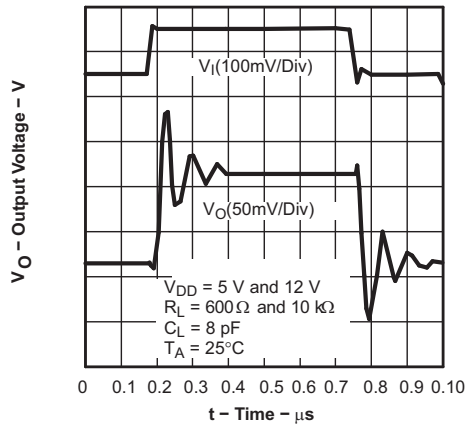

Figure 33. Small-Signal Follower Pulse Response

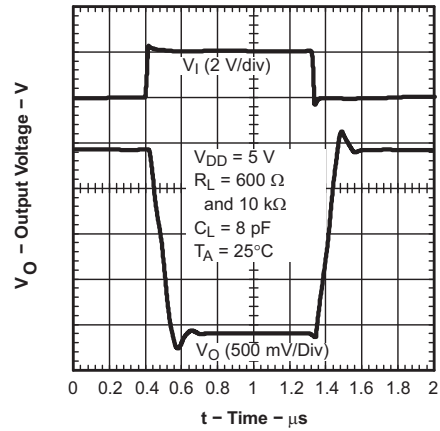

Figure 34. Large-Signal Follower Pulse Response

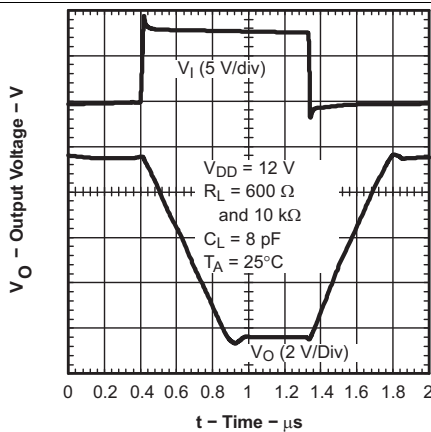

Figure 35. Large-Signal Inverting Pulse Response

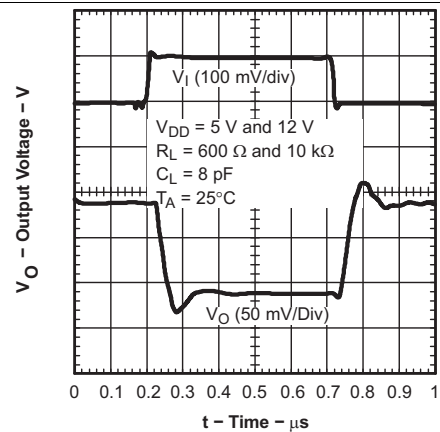

Figure 36. Small-Signal Inverting Pulse Response

## 7 Parameter Measurement Information

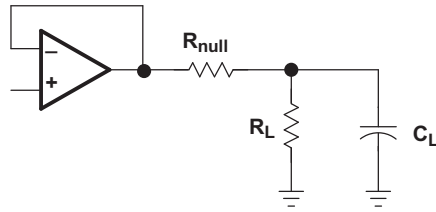

Figure 37. Voltage Follower Circuit

## 8 Detailed Description

### 8.1 Overview

The TLC08x-Q1 BiCMOS amplifiers provide an upgrade path for BiFET users who are moving away from dual-supply to single-supply systems and demand higher AC and DC performance. With performance rated from 4.5 V to 16 V across an automotive temperature range (–40°C to 125°C), BiMOS suits a wide range of audio, automotive, industrial, and instrumentation applications. BiCMOS amplifiers combine a very high input low-noise CMOS front end drive bipolar output stage, thus providing the optimum performance features of both. AC performance include a bandwidth of 10 MHz and voltage noise of 8.5 nV/√Hz.

### 8.2 Functional Block Diagram

Operational Amplifier

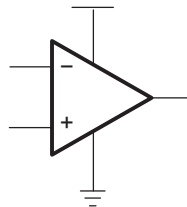

### 8.3 Feature Description

The TLC08x-Q1 family features 10-MHz bandwidth and voltage noise of 8.5 nV/√Hz with performance rated from 4.5 V to 16 V across an automotive temperature range (–40°C to 125°C). BiMOS suits a wide range of audio, automotive, industrial, and instrumentation applications.

### 8.4 Device Functional Modes

The TLC08x-Q1 family of devices is powered on when the supply is connected. The device can operate with single or dual supply, depending on the application. The device is in its full performance once the supply is above the recommended value.

### 8.5 Programming

#### 8.5.1 Macromodel Information

Derivation of the provided macromodel information was by use of Microsim Parts™, the model generation software used with Microsim PSpice™. The Boyle macromodel <sup>(1)</sup> and subcircuit in [Figure 38](#) are generated using the TLC08x-Q1 typical electrical and operating characteristics at T<sub>A</sub> = 25°C. Using this information, output simulations of the following key parameters can be generated to a tolerance of 20% (in most cases):

- Maximum positive output voltage swing
- Maximum negative output voltage swing
- Slew rate
- Quiescent power dissipation
- Input bias current
- Open-loop voltage amplification
- Unity-gain frequency
- Common-mode rejection ratio
- Phase margin
- DC output resistance
- AC output resistance
- Short-circuit output current limit

(1) G. R. Boyle, B. M. Cohn, D. O. Pederson, and J. E. Solomon, *Macromodeling of Integrated Circuit Operational Amplifiers*, IEEE Journal of Solid-State Circuits, SC-9, 353 (1974).

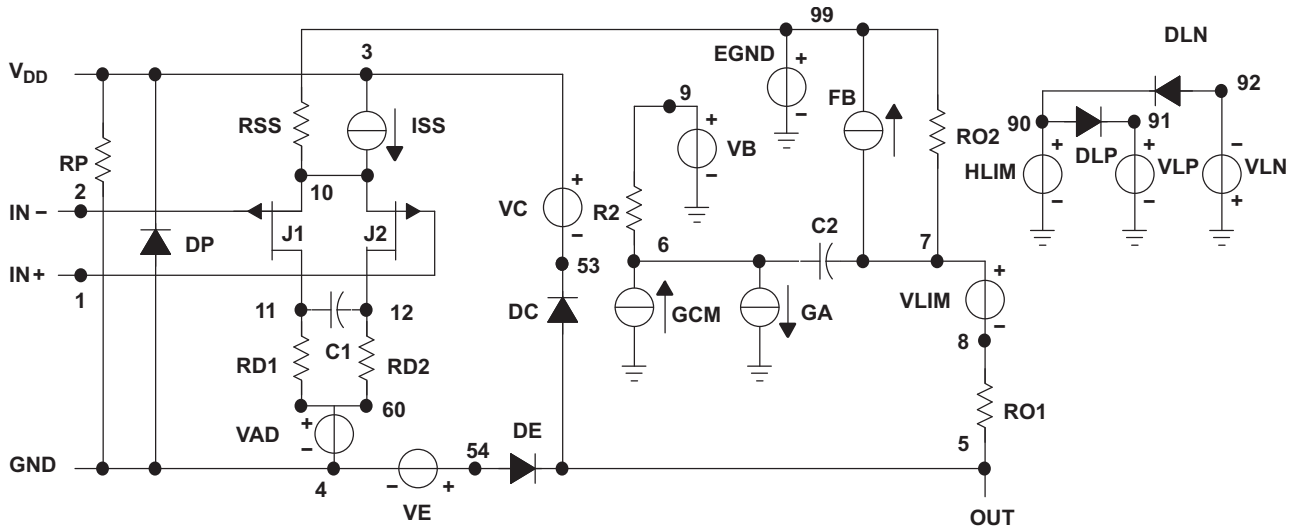

\*DEVICE=TLC08X\_5VOPAMP, PJF, INT

\* TLC08X\_5V - 5V operational amplifier "macromodel" subcircuit  
 \* created using Parts release 8.0 on 12/16/99 at 14:03  
 \* Parts is a MicroSim product.

\* connections:  
 \* non-inverting input  
 \* inverting input  
 \* positive power supply  
 \* negative power supply  
 \* output

.subckt TLC08X\_5V 1 2 3 4 5

```

*
c1 11 12 4.6015E-12
c2 6 7 8.0000E-12
css 10 99 986.29E-15
dc 5 53 dy
de 54 5 dy
dlp 90 91 dx
dln 92 90 dx
dp 4 3 dx
egnd 99 0 poly(2) (3,0) (4,0) 0 .5 .5
fb 7 99 poly(5) vb vc ve vlp vln 0 13.984E6 -1E3 1E3
14E6 -14E6
    
```

```

ga 6 0 11 12 402.12E-6
gcm 0 6 10 99 1.5735E-6
ioff 0 6 dc 1.212E-6
iss 3 10 dc 130.40E-6
hlim 90 0 vlim 1K
j1 11 2 10 jx1
j2 12 1 10 jx2
r2 6 9 100.00E3
rd1 4 11 2.4868E3
rd2 4 12 2.4868E3
ro1 8 5 10
ro2 7 99 10
rp 3 4 2.8249E3
rss 10 99 1.5337E6
vb 9 0 dc 0
vc 3 53 dc 1.5537
ve 54 4 dc .84373
vlim 7 8 dc 0
vlp 91 0 dc 117.60
vln 0 92 dc 117.60
.model dx D(Is=800.00E-18)
.model dy D(Is=800.00E-18 Rs=1m Cjo=10p)
.model jx1 PJF(Is=80.000E-15 Beta=1.2401E-3 Vto=-1)
.model jx2 PJF(Is=80.000E-15 Beta=1.2401E-3 Vto=-1)
.ends
    
```

Figure 38. Boyle Macromodel and Subcircuit

## 9 Application and Implementation

### NOTE

Information in the following applications sections is not part of the TI component specification, and TI does not warrant its accuracy or completeness. TI's customers are responsible for determining suitability of components for their purposes. Customers should validate and test their design implementation to confirm system functionality.

### 9.1 Application Information

The TLC08x-Q1 devices features wide supply voltage range, high-output current drive in the order of 60 mA, low input offset voltage, a high unity gain bandwidth 10 MHz and high slew of 16 V/μS. These features make the device suitable in amplifying high-frequency and slew rate signals.

### 9.2 Typical Applications

#### 9.2.1 TLC08x-Q1 Single-Supply Typical Application

Some applications require amplification of low amplitude and relatively high-frequency input signal. The sine wave maximum slew rate is at zero crossing. The amplified signal distorts if the minimum slew rate is not met. Operational amplifier slew rate must be higher than  $2 \times \pi \times F \times V$ , where F is the input signal frequency and V is the output signal amplitude. TLC08x-Q1 Slew rate of 16 V/μS is capable of delivering an output signal of 2-V peak and 1-MHz frequency with no distortion. See [Figure 45](#) for an application curve that shows the results of [Figure 39](#).

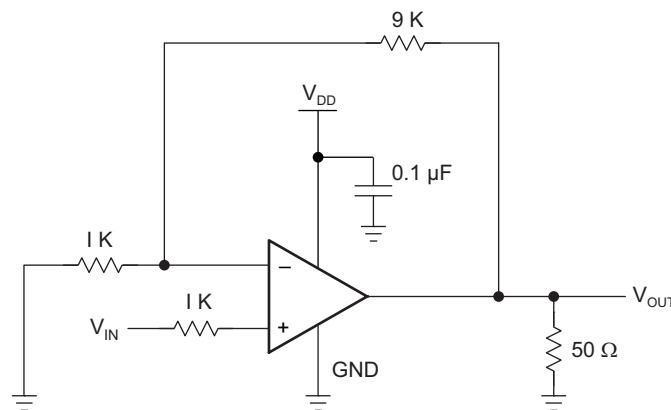

**Figure 39. TLC08x-Q1 Typical Application**

#### 9.2.1.1 Design Requirements

Use the following parameters for this design example:

- Noninverting configuration with gain of 10 or 20 dB
- Single supply minimum: 4.5 V
- Single supply maximum: 16 V
- Output common mode minimum should be higher than output level  $V_{OL}$
- Output common mode maximum should be lower than output level  $V_{OH}$
- Unity gain bandwidth: 10 MHz
- Output load current lower than 60 mA
- Maximum input signal frequency below 1 MHz for less than -3-dB attenuation at 1 MHz

## Typical Applications (continued)

### 9.2.1.2 Detailed Design Procedure

#### 9.2.1.2.1 Driving a Capacitive Load

When the amplifier is configured in this manner, capacitive loading directly on the output decreases the device phase margin, leading to high-frequency ringing or oscillations. Therefore, for capacitive loads of greater than 10 pF, TI recommends placing a resistor in series ( $R_{NULL}$ ) with the output of the amplifier, as shown in Figure 40. A minimum value of 20  $\Omega$  should work well for most applications.

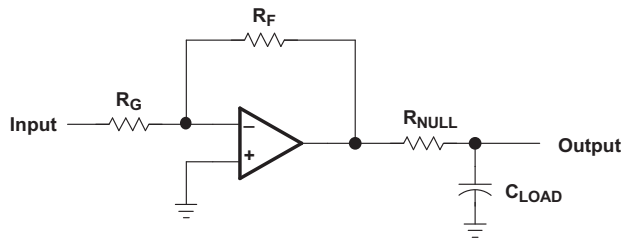

Figure 40. Driving a Capacitive Load

#### 9.2.1.2.2 Offset Voltage

The output offset voltage, ( $V_{OO}$ ) is the sum of the input offset voltage ( $V_{IO}$ ) and both input bias currents ( $I_{IB}$ ) times the corresponding gains. The schematic and formula in Figure 41 can be used to calculate the output offset voltage.

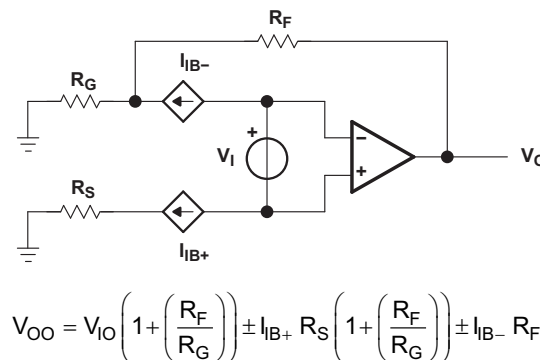

Figure 41. Output Offset Voltage Model

#### 9.2.1.2.3 High-Speed CMOS Input Amplifiers

The TLC08x-Q1 is a family of high-speed low-noise CMOS input operational amplifiers that has an input capacitance on the order of 20 pF. Any resistor used in the feedback path adds a pole in the transfer function equivalent to the input capacitance multiplied by the combination of source resistance and feedback resistance. For example, a gain of  $-10$ , a source resistance of 1 k $\Omega$ , and a feedback resistance of 10 k $\Omega$  add an additional pole at approximately 8 MHz. This is more apparent with CMOS amplifiers than bipolar amplifiers due to their greater input capacitance.

This is of little consequence on slower CMOS amplifiers, as this pole normally occurs at frequencies above their unity-gain bandwidth. However, the TLC08x-Q1 with its 10-MHz bandwidth means that this pole normally occurs at frequencies where there is on the order of 5-dB gain left and the phase shift adds considerably.

The effect of this pole is the strongest with large feedback resistances at small closed-loop gains. As the feedback resistance is increased, the gain peaking increases at a lower frequency and the 180° phase-shift crossover point also moves down in frequency, decreasing the phase margin.

For the TLC08x-Q1, the maximum feedback resistor recommended is 5 k $\Omega$ ; larger resistances can be used but a capacitor in parallel with the feedback resistor is recommended to counter the effects of the input capacitance pole.

### Typical Applications (continued)

The TLC08x-Q1 with a 1-V step response has an 80% overshoot with a natural frequency of 3.5 MHz when configured as a unity gain buffer and with a 10-kΩ feedback resistor. By adding a 10-pF capacitor in parallel with the feedback resistor, the overshoot is reduced to 40% and eliminates the natural frequency, resulting in a much faster settling time (see Figure 42). The 10-pF capacitor was chosen for convenience only.

Load capacitance had little effect on these measurements due to the excellent output drive capability of the TLC08x-Q1.

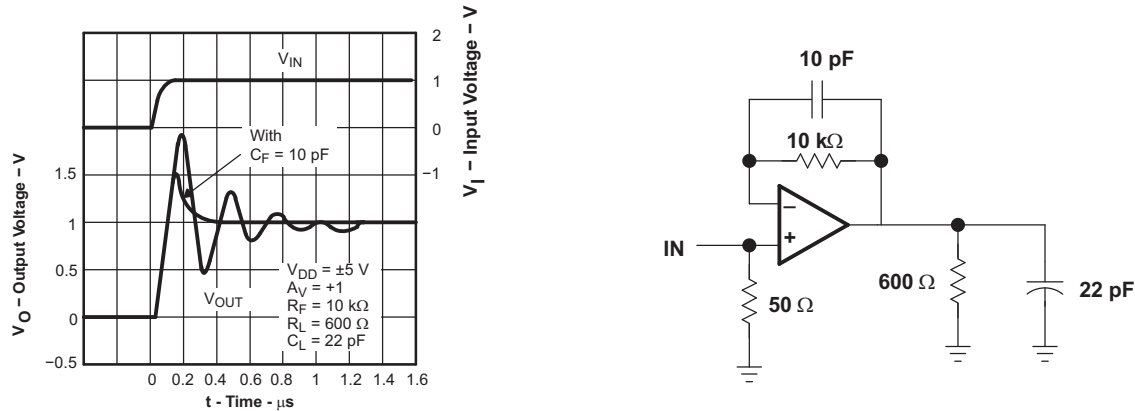

Figure 42. 1-V Step Response

#### 9.2.1.2.4 General Configurations

When receiving low-level signals, limiting the bandwidth of the incoming signals into the system is often required. The simplest way to accomplish this is to place an RC filter at the noninverting terminal of the amplifier (see Figure 43).

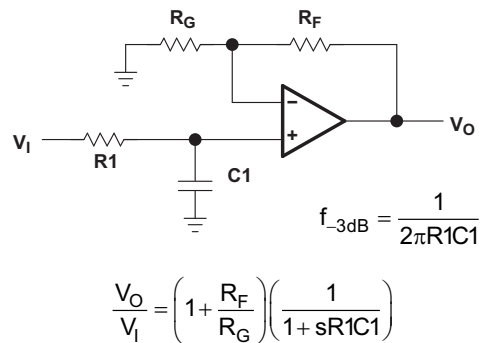

Figure 43. Single-Pole Low-Pass Filter

If even more attenuation is needed, a multiple-pole filter is required. The Sallen-Key filter can be used for this task. For best results, the amplifier should have a bandwidth that is eight to ten times the filter frequency bandwidth. Failure to do this can result in phase shift of the amplifier.

Typical Applications (continued)

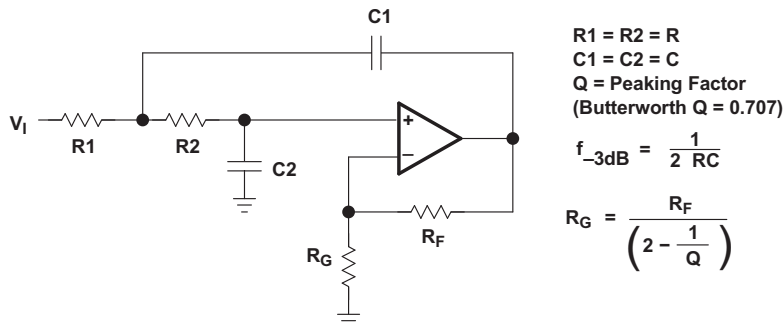
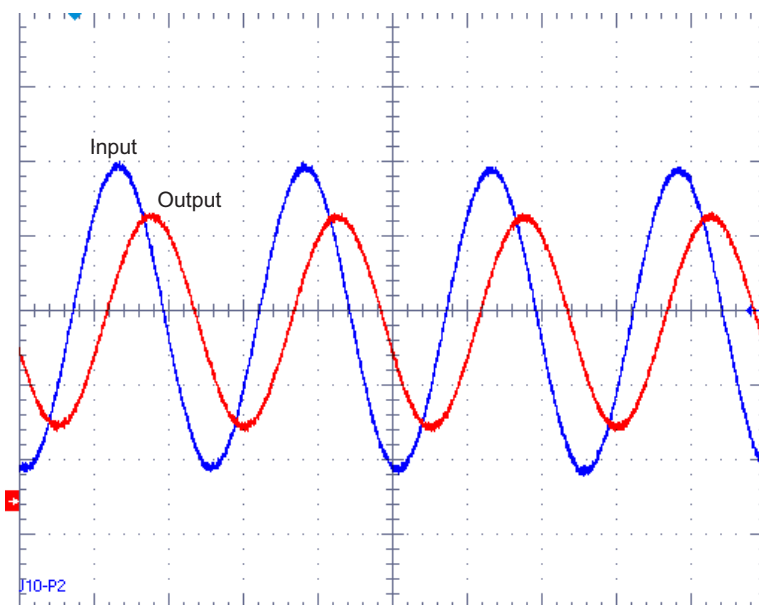

Figure 44. 2-Pole Low-Pass Sallen-Key Filter

9.2.1.3 Application Curve



Gain  $V_{out} / V_{in} = 1.471 \text{ V} / 0.2 \text{ V} = 7.335$

Gain(db) =  $20 \text{ Log} (7.335) = 17.33 \text{ dB}$

and is 2.7 dB below 10 dB

Figure 45. Single Supply Application at 1-MHz Input Signal

## Typical Applications (continued)

### 9.2.2 Dual-Supply Typical Application

The dual-supply application has a gain of 10 and a bandwidth of 1 MHz.

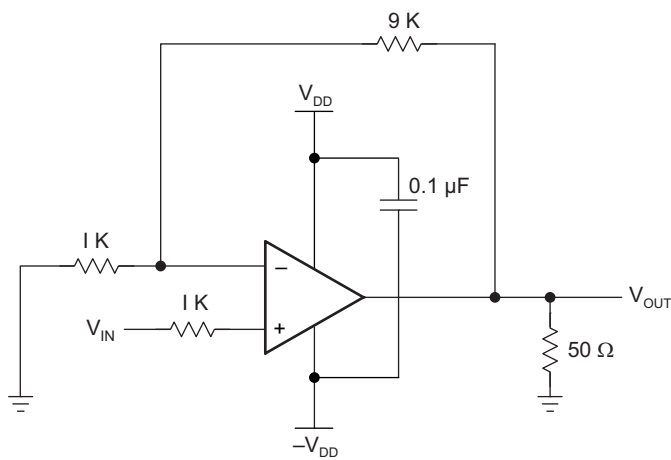

**Figure 46. Dual Supply Typical Application Schematic**

#### 9.2.2.1 Design Requirements

Use the following parameters for this design example:

- Noninverting configuration with gain of 10 or 20 dB
- Dual supply minimum:  $\pm 2.25$  V
- Dual supply maximum:  $\pm 8$  V
- Output common mode minimum should be higher than output level  $V_{OL}$
- Output common mode maximum should be lower than output level  $V_{OH}$
- Unity gain bandwidth: 10 MHz
- Maximum input signal frequency is 1 MHz for less than 3-dB attenuation at 1 MHz
- Output load current lower than 60 mA

#### 9.2.2.2 Detailed Design Procedure

For this example, see [Detailed Design Procedure](#) in *TLC08x-Q1 Single-Supply Typical Application*.

## Typical Applications (continued)

### 9.2.2.3 Application Curve

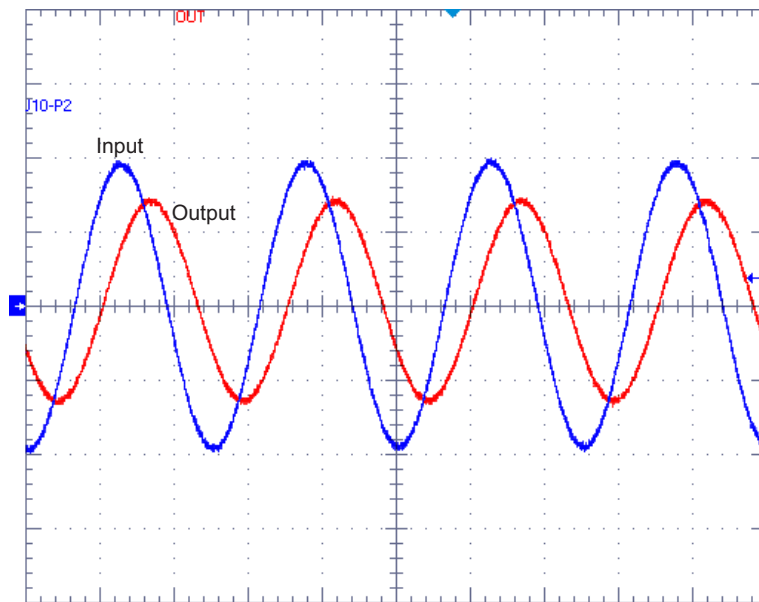

Figure 47. Dual Supply Application at 1-MHz Input Signal

## 10 Power Supply Recommendations

The TLC08x-Q1 operational amplifier is specified for use on a single supply from 4.5 V to 16 V (or a dual supply from over a temperature range of  $-40^{\circ}\text{C}$  to  $125^{\circ}\text{C}$ ). The device continues to function below this range, but performance is not specified. Place bypass capacitors close to the power supply pins to reduce noise coupling in from noisy or high-impedance power supplies. For more detailed information on bypass capacitor placement, see [Layout Guidelines](#).

## 11 Layout

### 11.1 Layout Guidelines

To achieve the levels of high performance of the TLC08x-Q1, follow proper printed-circuit board (PCB) design techniques. A general set of guidelines is given in the following.

**Ground planes** TI highly recommends using a ground plane on the board to provide all components with a low-inductive ground connection. However, in the areas of the amplifier inputs and output, the ground plane can be removed to minimize the stray capacitance.

**Proper power-supply decoupling** Use a  $6.8\text{-}\mu\text{F}$  tantalum capacitor in parallel with a  $0.1\text{-}\mu\text{F}$  ceramic capacitor on each supply terminal. It may be possible to share the tantalum among several amplifiers depending on the application, but a  $0.1\text{-}\mu\text{F}$  ceramic capacitor should always be used on the supply terminal of every amplifier. In addition, the  $0.1\text{-}\mu\text{F}$  capacitor should be placed as close as possible to the supply terminal. As this distance increases, the inductance in the connecting trace makes the capacitor less effective. The designer should strive for distances of less than 0.1 inches between the device power terminals and the ceramic capacitors.

**Sockets** Sockets can be used but are not recommended. The additional lead inductance in the socket pins will often lead to stability problems. Surface-mount packages soldered directly to the PCB is the best implementation.

## Layout Guidelines (continued)

**Short trace runs and compact part placements** Optimum high performance is achieved when stray series inductance has been minimized. To realize this, the circuit layout should be made as compact as possible, thereby minimizing the length of all trace runs. Particular attention should be paid to the inverting input of the amplifier. Its length should be kept as short as possible. This helps minimize stray capacitance at the input of the amplifier.

**Surface-mount passive components** TI recommends using surface-mount passive components for high-performance amplifier circuits for several reasons. First, because of the extremely low lead inductance of surface-mount components, the problem with stray series inductance is greatly reduced. Second, the small size of surface-mount components naturally leads to a more-compact layout, thereby minimizing both stray inductance and capacitance. If leaded components are used, TI recommends keeping the lead lengths as short as possible.

### 11.1.1 General PowerPAD™ Design Considerations

The TLC08x-Q1 is available in a thermally-enhanced PowerPAD family of packages. These packages are constructed using a downset leadframe upon which the die is mounted [see [Figure 48\(a\)](#) and [Figure 48\(b\)](#)]. This arrangement results in the lead frame being exposed as a thermal pad on the underside of the package [see [Figure 48\(c\)](#)]. Because this thermal pad has direct thermal contact with the die, excellent thermal performance can be achieved by providing a good thermal path away from the thermal pad.

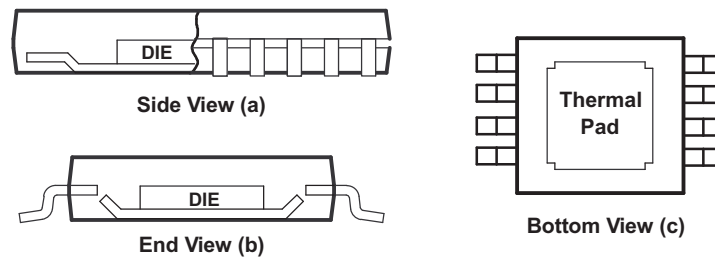

NOTE A: The thermal pad is electrically isolated from all terminals in the package.

**Figure 48. Views of Thermally-Enhanced DGN Package**

The PowerPAD package allows for both assembly and thermal management in one manufacturing operation. During the surface-mount solder operation (when the leads are being soldered), the thermal pad must be soldered to a copper area underneath the package. Through the use of thermal paths within this copper area, heat can be conducted away from the package into either a ground plane or other heat dissipating device.

#### NOTE

Soldering the thermal pad to the PCB is always required, even with applications that have low power dissipation.

This soldering provides the necessary thermal and mechanical connection between the lead frame die pad and the PCB. Although there are many ways to properly heatsink the PowerPAD package, the following steps list the recommended approach.

The thermal pad must be connected to the most-negative supply voltage (GND pin potential) of the device.

1. Prepare the PCB with a top-side etch pattern (see the landing patterns at the end of this data sheet). There should be etch for the leads, as well as etch for the thermal pad.
2. Place five holes (dual) or nine holes (quad) in the area of the thermal pad. These holes should be 13 mils in diameter. Keep them small so that solder wicking through the holes is not a problem during reflow.
3. Additional vias may be placed anywhere along the thermal plane outside of the thermal pad area. This helps dissipate the heat generated by the TLC08x-Q1 device. These additional vias may be larger than the 13-mil diameter vias directly under the thermal pad. They can be larger because they are not in the thermal-pad area to be soldered, so that wicking is not a problem.
4. Connect all holes to the internal plane that is at the same potential as the ground pin of the device.

## Layout Guidelines (continued)

5. When connecting these holes to this internal plane, do not use the typical web or spoke via connection methodology. Web connections have a high-thermal-resistance connection that is useful for slowing the heat transfer during soldering operations. This makes the soldering of vias that have plane connections easier. In this application, however, low thermal resistance is desired for the most efficient heat transfer. Therefore, the holes under the TLC08x-Q1 PowerPAD package should make their connection to the internal ground plane with a complete connection around the entire circumference of the plated-through hole.
6. The top-side solder mask should leave the terminals of the package and the thermal-pad area with its five holes (dual) or nine holes (quad) exposed. The bottom-side solder mask should cover the five or nine holes of the thermal-pad area. This prevents solder from being pulled away from the thermal-pad area during the reflow process.
7. Apply solder paste to the exposed thermal-pad area and all of the IC terminals.
8. With these preparatory steps in place, the TLC08x-Q1 IC is simply placed in position and run through the solder reflow operation as any standard surface-mount component. This results in a part that is properly installed.

For a given  $R_{\theta JA}$ , use [Equation 1](#) to calculate the maximum power dissipation.

$$P_D = \left( \frac{T_{MAX} - T_A}{R_{\theta JA}} \right)$$

Where:

- $P_D$  = Maximum power dissipation of TLC08x IC (watts)
  - $T_{MAX}$  = Absolute maximum junction temperature (150°C)
  - $T_A$  = Free-ambient air temperature (°C)
  - $R_{\theta JA} = R_{\theta JC} + R_{\theta CA}$
  - $R_{\theta JC}$  = Thermal coefficient from junction to case
  - $R_{\theta CA}$  = Thermal coefficient from case to ambient air (°C/W)
- (1)

The next consideration is the package constraints. The two sources of heat within an amplifier are quiescent power and output power. The designer should never forget about the quiescent heat generated within the device, especially multi-amplifier devices. Because these devices have linear output stages (class A-B), most of the heat dissipation is at low-output voltages with high-output currents.

The other key factor when dealing with power dissipation is how the devices are mounted on the PCB. The PowerPAD devices are extremely useful for heat dissipation. But, the device should always be soldered to a copper plane to fully use the heat dissipation properties of the thermal pad. The SOIC package, on the other hand, is highly dependent on how it is mounted on the PCB. As more trace and copper area is placed around the device,  $R_{\theta JA}$  decreases and the heat dissipation capability increases. The currents and voltages shown in [Typical Characteristics](#) are for the total package. For the dual or quad amplifier packages, the sum of the RMS output currents and voltages should be used to choose the proper package.

TLC082-Q1, TLC084-Q1

SLOS510E – SEPTEMBER 2006 – REVISED OCTOBER 2016

www.ti.com

11.2 Layout Example

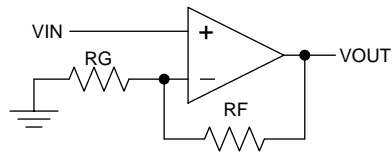

(Schematic Representation)

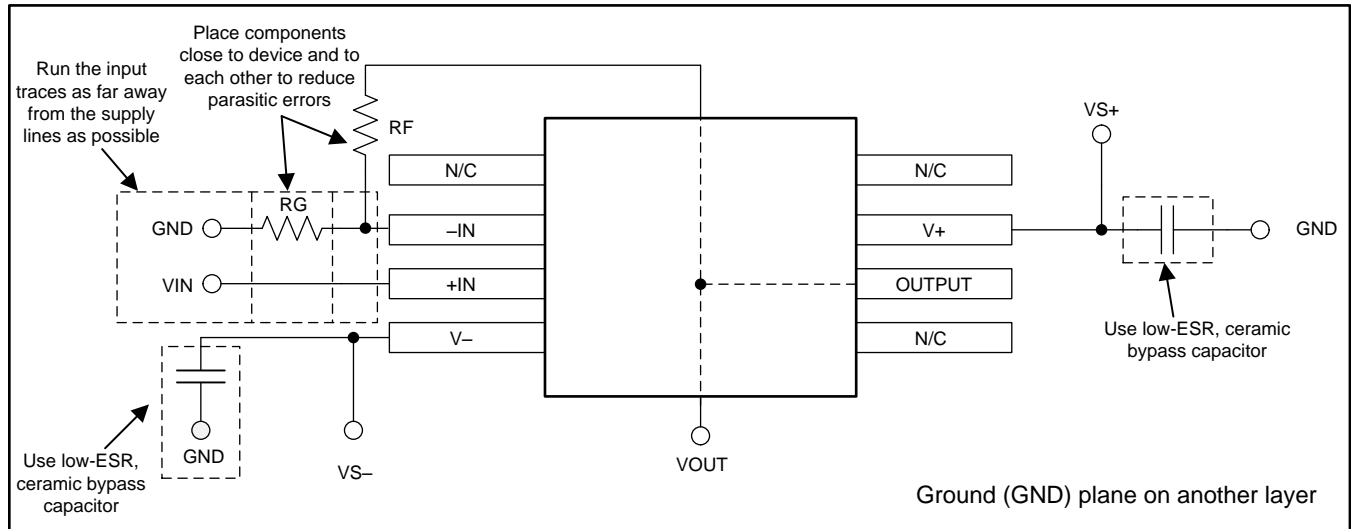

Figure 49. Operational Amplifier Board Layout for Noninverting Configuration

## 12 Device and Documentation Support

### 12.1 Documentation Support

#### 12.1.1 Related Documentation

For related documentation see the following:

[TLC081 EMI Immunity Performance](#) (SBOT011)

### 12.2 Related Links

The table below lists quick access links. Categories include technical documents, support and community resources, tools and software, and quick access to sample or buy.

**Table 2. Related Links**

PARTS	PRODUCT FOLDER	SAMPLE & BUY	TECHNICAL DOCUMENTS	TOOLS & SOFTWARE	SUPPORT & COMMUNITY
TLC082-Q1	<a href="#">Click here</a>	<a href="#">Click here</a>	<a href="#">Click here</a>	<a href="#">Click here</a>	<a href="#">Click here</a>
TLC084-Q1	<a href="#">Click here</a>	<a href="#">Click here</a>	<a href="#">Click here</a>	<a href="#">Click here</a>	<a href="#">Click here</a>

### 12.3 Receiving Notification of Documentations Updates

To receive notification of documentation updates, navigate to the device product folder on ti.com. In the upper right corner, click on *Alert me* to register and receive a weekly digest of any product information that has changed. For change details, review the revision history included in any revised document.

### 12.4 Community Resources

The following links connect to TI community resources. Linked contents are provided "AS IS" by the respective contributors. They do not constitute TI specifications and do not necessarily reflect TI's views; see TI's [Terms of Use](#).

**TI E2E™ Online Community** *TI's Engineer-to-Engineer (E2E) Community*. Created to foster collaboration among engineers. At e2e.ti.com, you can ask questions, share knowledge, explore ideas and help solve problems with fellow engineers.

**Design Support** *TI's Design Support* Quickly find helpful E2E forums along with design support tools and contact information for technical support.

### 12.5 Trademarks

PowerPAD, E2E are trademarks of Texas Instruments.  
 Parts, PSpice are trademarks of MicroSim Corporation.  
 All other trademarks are the property of their respective owners.

### 12.6 Electrostatic Discharge Caution



These devices have limited built-in ESD protection. The leads should be shorted together or the device placed in conductive foam during storage or handling to prevent electrostatic damage to the MOS gates.

### 12.7 Glossary

[SLYZ022](#) — *TI Glossary*.

This glossary lists and explains terms, acronyms, and definitions.

## 13 Mechanical, Packaging, and Orderable Information

The following pages include mechanical, packaging, and orderable information. This information is the most-current data available for the designated devices. This data is subject to change without notice and without revision of this document. For browser-based versions of this data sheet, refer to the left-hand navigation pane.

**PACKAGING INFORMATION**

Orderable Device	Status (1)	Package Type	Package Drawing	Pins	Package Qty	Eco Plan (2)	Lead/Ball Finish (6)	MSL Peak Temp (3)	Op Temp (°C)	Device Marking (4/5)	Samples
TLC082QDGNRQ1	ACTIVE	MSOP- PowerPAD	DGN	8	2500	Green (RoHS & no Sb/Br)	CU NIPDAU	Level-3-260C-168 HR	-40 to 125	QXO	<a href="#">Samples</a>
TLC084QPWPRQ1	ACTIVE	HTSSOP	PWP	20	2000	Green (RoHS & no Sb/Br)	CU NIPDAU	Level-3-260C-168 HR	-40 to 125	TLC084Q	<a href="#">Samples</a>

(1) The marketing status values are defined as follows:

**ACTIVE:** Product device recommended for new designs.

**LIFEBUY:** TI has announced that the device will be discontinued, and a lifetime-buy period is in effect.

**NRND:** Not recommended for new designs. Device is in production to support existing customers, but TI does not recommend using this part in a new design.

**PREVIEW:** Device has been announced but is not in production. Samples may or may not be available.

**OBSELETE:** TI has discontinued the production of the device.

(2) Eco Plan - The planned eco-friendly classification: Pb-Free (RoHS), Pb-Free (RoHS Exempt), or Green (RoHS & no Sb/Br) - please check <http://www.ti.com/productcontent> for the latest availability information and additional product content details.

**TBD:** The Pb-Free/Green conversion plan has not been defined.

**Pb-Free (RoHS):** TI's terms "Lead-Free" or "Pb-Free" mean semiconductor products that are compatible with the current RoHS requirements for all 6 substances, including the requirement that lead not exceed 0.1% by weight in homogeneous materials. Where designed to be soldered at high temperatures, TI Pb-Free products are suitable for use in specified lead-free processes.

**Pb-Free (RoHS Exempt):** This component has a RoHS exemption for either 1) lead-based flip-chip solder bumps used between the die and package, or 2) lead-based die adhesive used between the die and leadframe. The component is otherwise considered Pb-Free (RoHS compatible) as defined above.

**Green (RoHS & no Sb/Br):** TI defines "Green" to mean Pb-Free (RoHS compatible), and free of Bromine (Br) and Antimony (Sb) based flame retardants (Br or Sb do not exceed 0.1% by weight in homogeneous material)

(3) MSL, Peak Temp. - The Moisture Sensitivity Level rating according to the JEDEC industry standard classifications, and peak solder temperature.

(4) There may be additional marking, which relates to the logo, the lot trace code information, or the environmental category on the device.

(5) Multiple Device Markings will be inside parentheses. Only one Device Marking contained in parentheses and separated by a "~" will appear on a device. If a line is indented then it is a continuation of the previous line and the two combined represent the entire Device Marking for that device.

(6) Lead/Ball Finish - Orderable Devices may have multiple material finish options. Finish options are separated by a vertical ruled line. Lead/Ball Finish values may wrap to two lines if the finish value exceeds the maximum column width.

**Important Information and Disclaimer:** The information provided on this page represents TI's knowledge and belief as of the date that it is provided. TI bases its knowledge and belief on information provided by third parties, and makes no representation or warranty as to the accuracy of such information. Efforts are underway to better integrate information from third parties. TI has taken and continues to take reasonable steps to provide representative and accurate information but may not have conducted destructive testing or chemical analysis on incoming materials and chemicals. TI and TI suppliers consider certain information to be proprietary, and thus CAS numbers and other limited information may not be available for release.

In no event shall TI's liability arising out of such information exceed the total purchase price of the TI part(s) at issue in this document sold by TI to Customer on an annual basis.

**OTHER QUALIFIED VERSIONS OF TLC082-Q1, TLC084-Q1 :**

- Catalog: [TLC082](#), [TLC084](#)

**NOTE: Qualified Version Definitions:**

- Catalog - TI's standard catalog product

## TAPE AND REEL INFORMATION



### QUADRANT ASSIGNMENTS FOR PIN 1 ORIENTATION IN TAPE



\*All dimensions are nominal

Device	Package Type	Package Drawing	Pins	SPQ	Reel Diameter (mm)	Reel Width W1 (mm)	A0 (mm)	B0 (mm)	K0 (mm)	P1 (mm)	W (mm)	Pin1 Quadrant
TLC082QDGNRQ1	MSOP-Power PAD	DGN	8	2500	330.0	12.4	5.3	3.4	1.4	8.0	12.0	Q1

TAPE AND REEL BOX DIMENSIONS



\*All dimensions are nominal

Device	Package Type	Package Drawing	Pins	SPQ	Length (mm)	Width (mm)	Height (mm)
TLC082QDGNRQ1	MSOP-PowerPAD	DGN	8	2500	346.0	346.0	29.0

# MECHANICAL DATA

PWP (R-PDSO-G20)

PowerPAD™ PLASTIC SMALL OUTLINE

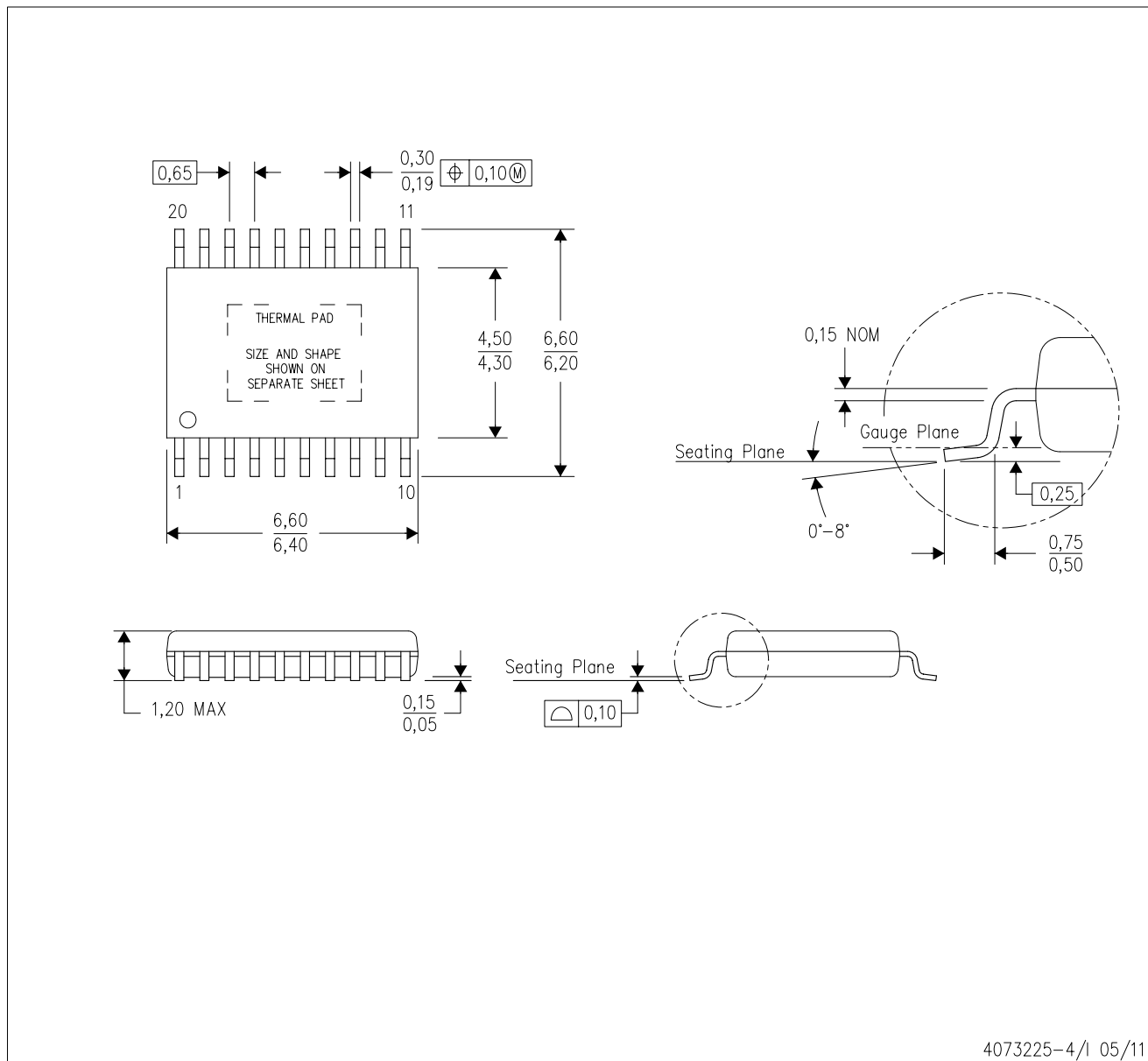

4073225-4/1 05/11

- NOTES:
- All linear dimensions are in millimeters.
  - This drawing is subject to change without notice.
  - Body dimensions do not include mold flash or protrusions. Mold flash and protrusion shall not exceed 0.15 per side.
  - This package is designed to be soldered to a thermal pad on the board. Refer to Technical Brief, PowerPad Thermally Enhanced Package, Texas Instruments Literature No. SLMA002 for information regarding recommended board layout. This document is available at [www.ti.com](http://www.ti.com) <<http://www.ti.com>>.
  - See the additional figure in the Product Data Sheet for details regarding the exposed thermal pad features and dimensions.
  - Falls within JEDEC MO-153

PowerPAD is a trademark of Texas Instruments.

# THERMAL PAD MECHANICAL DATA

## PWP (R-PDSO-G20) PowerPAD™ SMALL PLASTIC OUTLINE

### THERMAL INFORMATION

This PowerPAD™ package incorporates an exposed thermal pad that is designed to be attached to a printed circuit board (PCB). The thermal pad must be soldered directly to the PCB. After soldering, the PCB can be used as a heatsink. In addition, through the use of thermal vias, the thermal pad can be attached directly to the appropriate copper plane shown in the electrical schematic for the device, or alternatively, can be attached to a special heatsink structure designed into the PCB. This design optimizes the heat transfer from the integrated circuit (IC).

For additional information on the PowerPAD package and how to take advantage of its heat dissipating abilities, refer to Technical Brief, PowerPAD Thermally Enhanced Package, Texas Instruments Literature No. SLMA002 and Application Brief, PowerPAD Made Easy, Texas Instruments Literature No. SLMA004. Both documents are available at [www.ti.com](http://www.ti.com).

The exposed thermal pad dimensions for this package are shown in the following illustration.

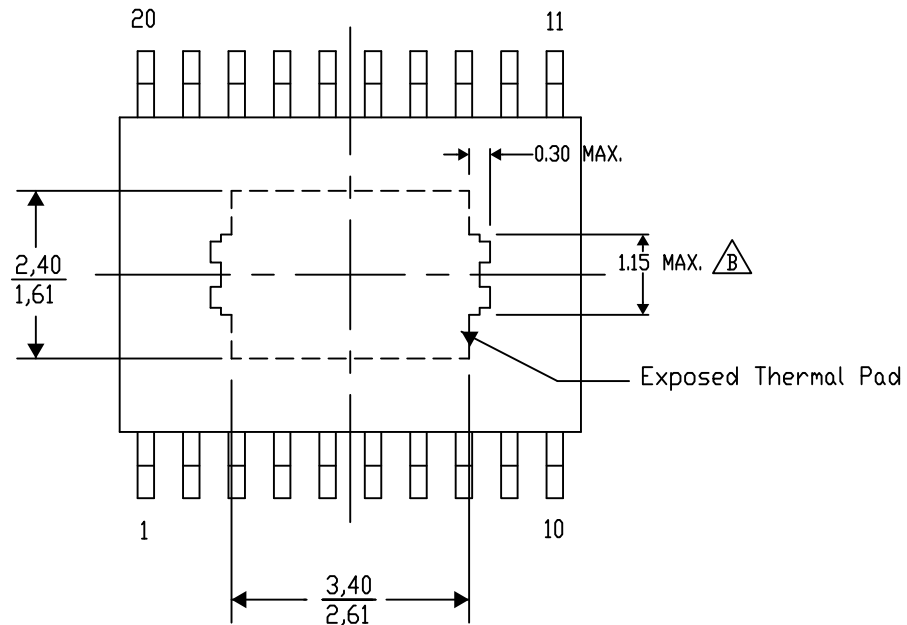

Top View

Exposed Thermal Pad Dimensions

4206332-15/AO 01/16

NOTE: A. All linear dimensions are in millimeters

 Exposed tie strap features may not be present.

PowerPAD is a trademark of Texas Instruments

PWP (R-PDSO-G20)

PowerPAD™ PLASTIC SMALL OUTLINE

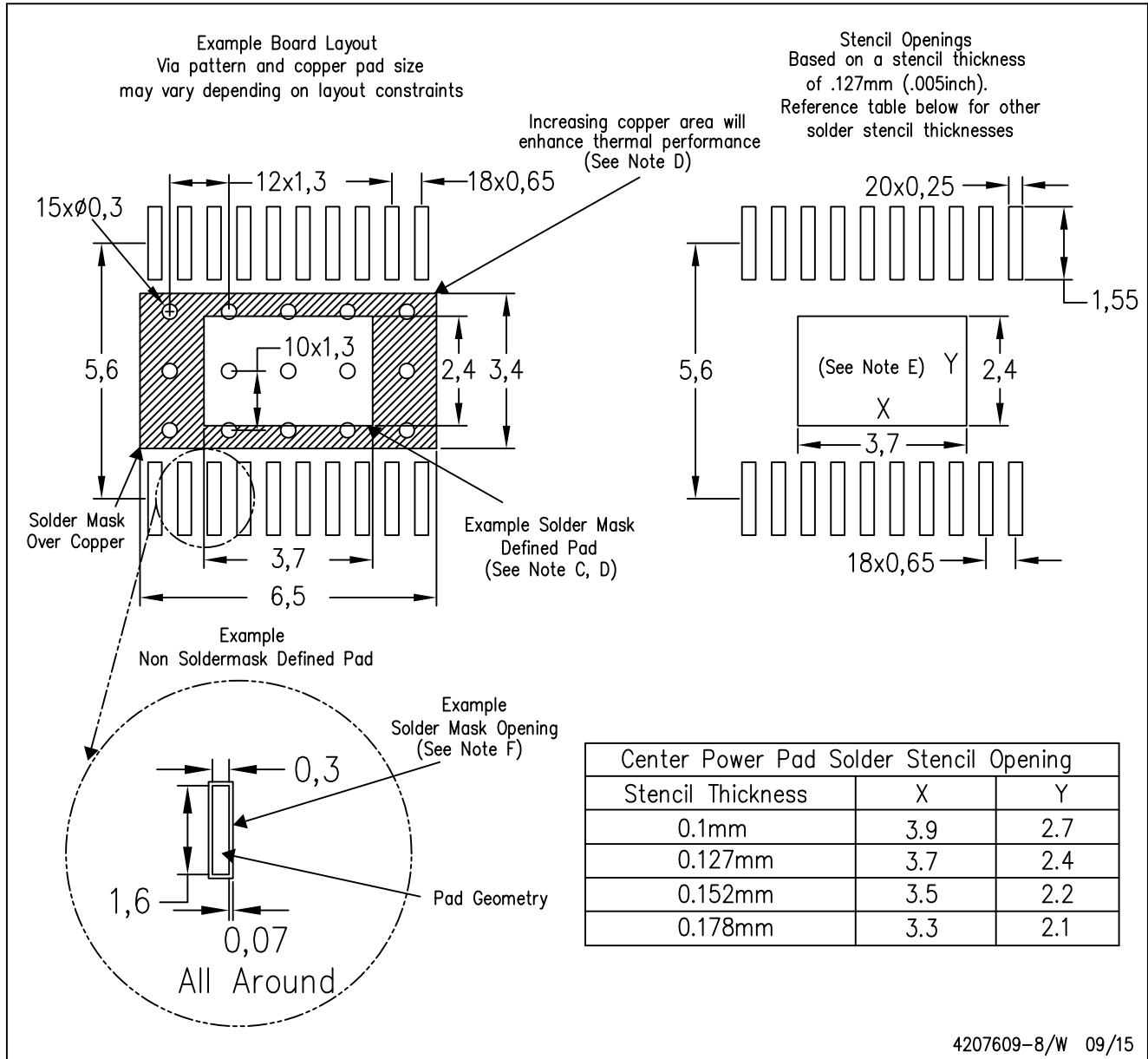

- NOTES:
- A. All linear dimensions are in millimeters.
  - B. This drawing is subject to change without notice.
  - C. Customers should place a note on the circuit board fabrication drawing not to alter the center solder mask defined pad.
  - D. This package is designed to be soldered to a thermal pad on the board. Refer to Technical Brief, PowerPad Thermally Enhanced Package, Texas Instruments Literature No. SLMA002, SLMA004, and also the Product Data Sheets for specific thermal information, via requirements, and recommended board layout. These documents are available at [www.ti.com](http://www.ti.com) <<http://www.ti.com>>. Publication IPC-7351 is recommended for alternate designs.
  - E. Laser cutting apertures with trapezoidal walls and also rounding corners will offer better paste release. Customers should contact their board assembly site for stencil design recommendations. Example stencil design based on a 50% volumetric metal load solder paste. Refer to IPC-7525 for other stencil recommendations.
  - F. Customers should contact their board fabrication site for solder mask tolerances between and around signal pads.

DGN (S-PDSO-G8)

PowerPAD™ PLASTIC SMALL OUTLINE

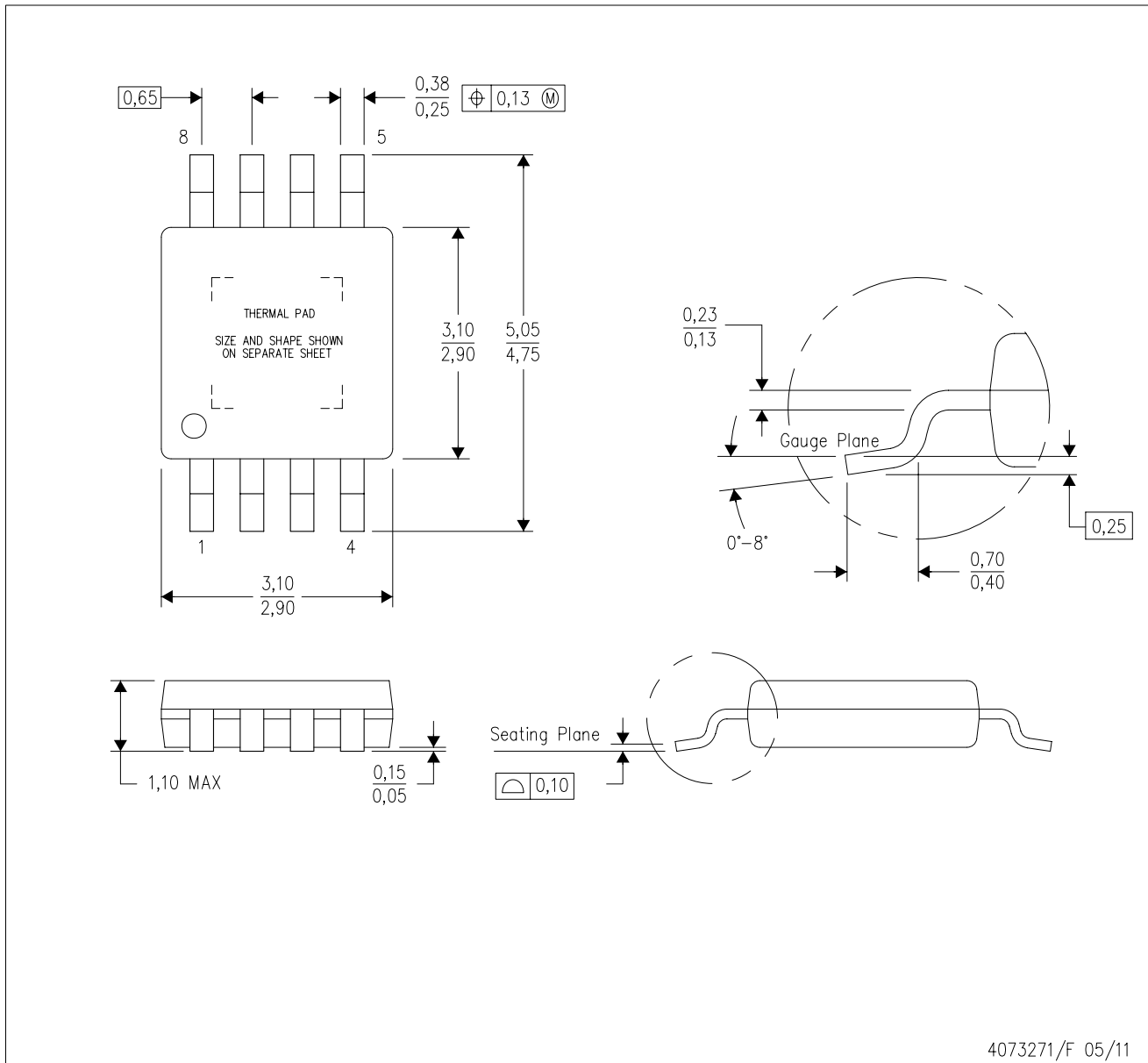

- NOTES:
- A. All linear dimensions are in millimeters.
  - B. This drawing is subject to change without notice.
  - C. Body dimensions do not include mold flash or protrusion.
  - D. This package is designed to be soldered to a thermal pad on the board. Refer to Technical Brief, PowerPad Thermally Enhanced Package, Texas Instruments Literature No. SLMA002 for information regarding recommended board layout. This document is available at [www.ti.com](http://www.ti.com) <<http://www.ti.com>>.
  - E. See the additional figure in the Product Data Sheet for details regarding the exposed thermal pad features and dimensions.
  - F. Falls within JEDEC MO-187 variation AA-T

PowerPAD is a trademark of Texas Instruments.

DGN (S-PDSO-G8)

PowerPAD™ PLASTIC SMALL OUTLINE

## THERMAL INFORMATION

This PowerPAD™ package incorporates an exposed thermal pad that is designed to be attached to a printed circuit board (PCB). The thermal pad must be soldered directly to the PCB. After soldering, the PCB can be used as a heatsink. In addition, through the use of thermal vias, the thermal pad can be attached directly to the appropriate copper plane shown in the electrical schematic for the device, or alternatively, can be attached to a special heatsink structure designed into the PCB. This design optimizes the heat transfer from the integrated circuit (IC).

For additional information on the PowerPAD package and how to take advantage of its heat dissipating abilities, refer to Technical Brief, PowerPAD Thermally Enhanced Package, Texas Instruments Literature No. SLMA002 and Application Brief, PowerPAD Made Easy, Texas Instruments Literature No. SLMA004. Both documents are available at [www.ti.com](http://www.ti.com).

The exposed thermal pad dimensions for this package are shown in the following illustration.

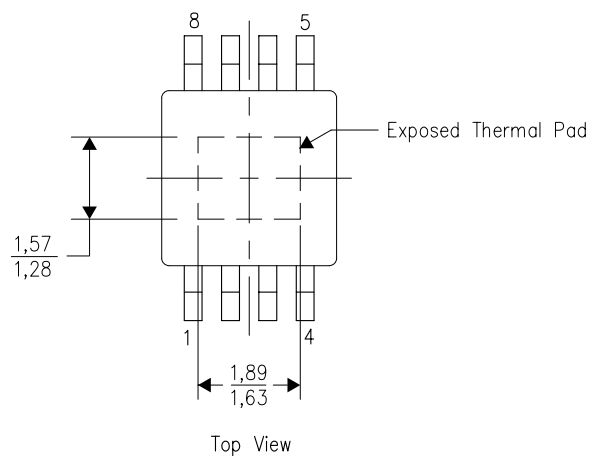

Exposed Thermal Pad Dimensions

4206323-2/1 12/11

NOTE: All linear dimensions are in millimeters

PowerPAD is a trademark of Texas Instruments

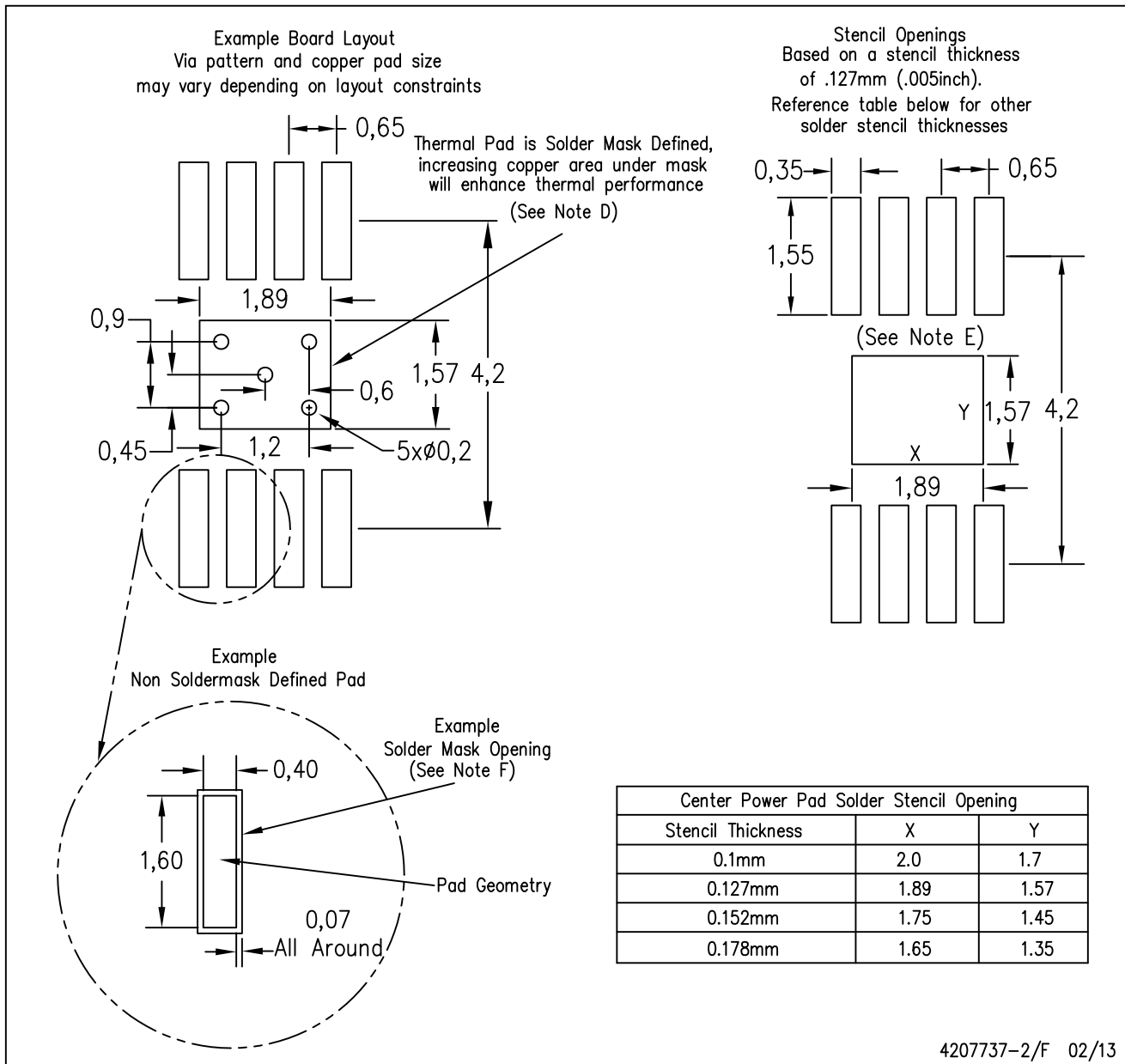

- NOTES:
- A. All linear dimensions are in millimeters.
  - B. This drawing is subject to change without notice.
  - C. Customers should place a note on the circuit board fabrication drawing not to alter the center solder mask defined pad.
  - D. This package is designed to be soldered to a thermal pad on the board. Refer to Technical Brief, PowerPad Thermally Enhanced Package, Texas Instruments Literature No. SLMA002, SLMA004, and also the Product Data Sheets for specific thermal information, via requirements, and recommended board layout. These documents are available at [www.ti.com](http://www.ti.com) <<http://www.ti.com>>.
  - E. Laser cutting apertures with trapezoidal walls and also rounding corners will offer better paste release. Customers should contact their board assembly site for stencil design recommendations. Example stencil design based on a 50% volumetric metal load solder paste. Refer to IPC-7525 for other stencil recommendations.
  - F. Customers should contact their board fabrication site for solder mask tolerances between and around signal pads.

PowerPAD is a trademark of Texas Instruments

## IMPORTANT NOTICE AND DISCLAIMER

TI PROVIDES TECHNICAL AND RELIABILITY DATA (INCLUDING DATASHEETS), DESIGN RESOURCES (INCLUDING REFERENCE DESIGNS), APPLICATION OR OTHER DESIGN ADVICE, WEB TOOLS, SAFETY INFORMATION, AND OTHER RESOURCES "AS IS" AND WITH ALL FAULTS, AND DISCLAIMS ALL WARRANTIES, EXPRESS AND IMPLIED, INCLUDING WITHOUT LIMITATION ANY IMPLIED WARRANTIES OF MERCHANTABILITY, FITNESS FOR A PARTICULAR PURPOSE OR NON-INFRINGEMENT OF THIRD PARTY INTELLECTUAL PROPERTY RIGHTS.

These resources are intended for skilled developers designing with TI products. You are solely responsible for (1) selecting the appropriate TI products for your application, (2) designing, validating and testing your application, and (3) ensuring your application meets applicable standards, and any other safety, security, or other requirements. These resources are subject to change without notice. TI grants you permission to use these resources only for development of an application that uses the TI products described in the resource. Other reproduction and display of these resources is prohibited. No license is granted to any other TI intellectual property right or to any third party intellectual property right. TI disclaims responsibility for, and you will fully indemnify TI and its representatives against, any claims, damages, costs, losses, and liabilities arising out of your use of these resources.

TI's products are provided subject to TI's Terms of Sale ([www.ti.com/legal/termsofsale.html](http://www.ti.com/legal/termsofsale.html)) or other applicable terms available either on [ti.com](http://ti.com) or provided in conjunction with such TI products. TI's provision of these resources does not expand or otherwise alter TI's applicable warranties or warranty disclaimers for TI products.

Mailing Address: Texas Instruments, Post Office Box 655303, Dallas, Texas 75265  
Copyright © 2019, Texas Instruments Incorporated







## Looking for pricing, stock, or lifecycle information?

Click below to explore more details on WIN SOURCE:

 [View TLC082QDGNRQ1](#) on WIN SOURCE

 [Texas Instruments](#) Information

## Optimize Your Supply Chain with WIN SOURCE Solutions

-  Global Sourcing Solution
-  Obsolete Management
-  Cost Control Management
-  Shortage Management
-  Alternative Solution
-  Excess Inventory Management