



**THE DATASHEET OF
TPS650245RHBR**



TPS65024x Power Management ICs for Li-Ion Powered Systems

1 Features

- 1.6-A, 1.0-A, or 0.8-A, 97% Efficient Step-Down Converter for System Voltage (VDCDC1)
 - 3.3 V or 2.80 V or Adjustable
- 1.6-A, 1.0-A, or 0.8-A, up to 95% Efficient Step-Down Converter for Memory Voltage (VDCDC2)
 - 1.8 V or 2.5 V or Adjustable
- 0.8-A, 90% Efficient Step-Down Converter for Processor Core (VDCDC3)
 - 1.8 V or 2.5 V or Adjustable
- Two Selectable Voltages for VDCDC3
 - TPS650240:
 - DEFDCDC3 = LOW: $V_O = 1.0\text{ V}$
 - DEFDCDC3 = HIGH: $V_O = 1.3\text{ V}$
 - TPS650241:
 - DEFDCDC3 = LOW: $V_O = 0.9\text{ V}$
 - DEFDCDC3 = HIGH: $V_O = 1.375\text{ V}$
 - TPS650242:
 - DEFDCDC3 = LOW: $V_O = 1.0\text{ V}$
 - DEFDCDC3 = HIGH: $V_O = 1.5\text{ V}$
 - TPS650243:
 - DEFDCDC3 = LOW: $V_O = 1.0\text{ V}$
 - DEFDCDC3 = HIGH: $V_O = 1.2\text{ V}$
 - TPS650244:
 - DEFDCDC3 = LOW: $V_O = 1.55\text{ V}$
 - DEFDCDC3 = HIGH: $V_O = 1.6\text{ V}$
 - TPS650245:
 - DEFDCDC3 = LOW: $V_O = 0.9\text{ V}$
 - DEFDCDC3 = HIGH: $V_O = 1.1\text{ V}$
- 30-mA LDO for Vdd_alive
- 2 × 200-mA General-Purpose LDOs (LDO1 and LDO2)
- Dynamic Voltage Management for Processor Core
- LDO1 and LDO2 Voltage Externally Adjustable
- Separate Enable Pins for Inductive Converters
- 2.25-MHz Switching Frequency
- 85- μA Quiescent Current
- Thermal Shutdown Protection

2 Applications

- Split-Supply DSP and μP Solutions, ARM-Based Processors, and so on
- Cellular and Smart Phones
- GPS
- Digital Cameras
- PDA

3 Description

The TPS65024x devices are integrated power management ICs for applications powered by one Li-Ion or Li-Polymer cell, which require multiple power rails. The TPS65024x provide three highly efficient, step-down converters targeted at providing the core voltage, peripheral, I/O, and memory rails in a processor-based system. All three step-down converters enter a low power mode at light load for maximum efficiency across the widest possible range of load currents. The converters can be forced into fixed-frequency PWM mode by pulling the MODE pin high.

Device Information⁽¹⁾

PART NUMBER	PACKAGE	BODY SIZE (NOM)
TPS65024x	VQFN (32)	5.00 mm × 5.00 mm

(1) For all available packages, see the orderable addendum at the end of the data sheet.

Functional Block Diagram

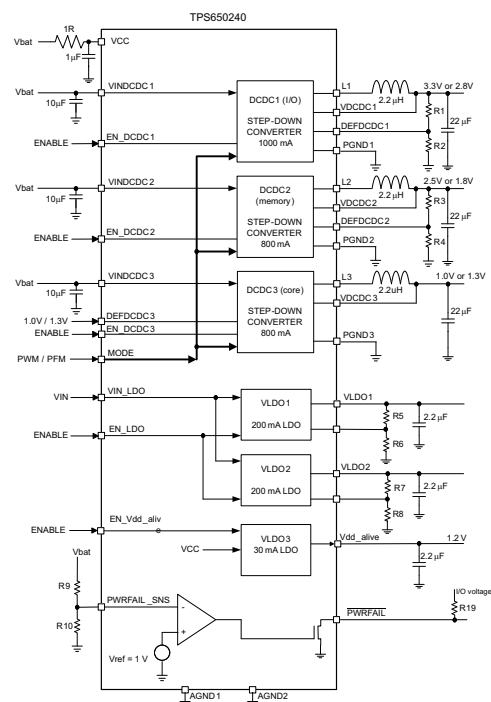

Table of Contents

1 Features	1	8.10 Typical Characteristics	12
2 Applications	1	9 Detailed Description	16
3 Description	1	9.1 Overview	16
4 Revision History	2	9.2 Functional Block Diagram	17
5 Description (continued)	3	9.3 Feature Description	18
6 Voltage Options	3	9.4 Device Functional Modes	19
7 Pin Configuration and Functions	4	10 Application and Implementation	21
8 Specifications	6	10.1 Application Information	21
8.1 Absolute Maximum Ratings	6	10.2 Typical Applications	23
8.2 ESD Ratings	6	11 Power Supply Recommendations	27
8.3 Recommended Operating Conditions	6	12 Layout	28
8.4 Thermal Information	7	12.1 Layout Guidelines	28
8.5 Electrical Characteristics: Control Signals and Supply Pins	7	12.2 Layout Example	28
8.6 Electrical Characteristics: VDCDC1 Step-Down Converter	8	13 Device and Documentation Support	29
8.7 Electrical Characteristics: VDCDC2 Step-Down Converter	9	13.1 Related Links	29
8.8 Electrical Characteristics: VDCDC3 Step-Down Converter	10	13.2 Community Resources	29
8.9 Electrical Characteristics: General	11	13.3 Trademarks	29
		13.4 Electrostatic Discharge Caution	29
		13.5 Glossary	29
		14 Mechanical, Packaging, and Orderable Information	29

4 Revision History

NOTE: Page numbers for previous revisions may differ from page numbers in the current version.

Changes from Revision B (July 2009) to Revision C

Page

- Added *ESD Ratings* table, *Feature Description* section, *Device Functional Modes*, *Application and Implementation* section, *Power Supply Recommendations* section, *Layout* section, *Device and Documentation Support* section, and *Mechanical, Packaging, and Orderable Information* section

1

Changes from Revision A (December 2007) to Revision B

Page

- Changed LDO1 output voltage range max value from VinLDO to 3.3V
- Changed LDO2 output voltage range max value from VinLDO to 3.3V

11

11

5 Description (continued)

The TPS65024x also integrates two general-purpose 200-mA LDO voltage regulators, which are enabled with an external input pin. Each LDO operates with an input voltage range between 1.5 V and 6.5 V, allowing them to be supplied from one of the step-down converters or directly from the battery. The output voltage of the LDOs can be set with an external resistor divider for maximum flexibility. Additionally there is a 30-mA LDO typically used to provide power in a processor-based system to a voltage rail that is always on. TPS65024x provide voltage scaling on DCDC3 using the DEFDCDC3 pin. This pin either needs to be connected to a logic HIGH or logic LOW level to set the output voltage of DCDC3. The TPS65024x comes in a small 5-mm × 5-mm, 32-pin VQFN package (RHB).

6 Voltage Options

PACKAGE ⁽¹⁾	PART NUMBER ⁽²⁾	VOLTAGE AT DCDC3	OUTPUT CURRENT ON DCDC1 / DCDC2 / DCDC3	VOLTAGE AT VDD_ALIVE	T _A
32-Pin VQFN (RHB)	TPS650240RHB	1.0 V / 1.3 V	1.0 A / 0.8 A / 0.8 A	1.2 V	–40°C to 85°C
	TPS650241RHB	0.9 V / 1.375 V	1.6 A / 1.0 A / 0.8 A	1.2 V	
	TPS650242RHB	1.0 V / 1.5 V	1.0 A / 0.8 A / 0.8 A	1.2 V	
	TPS650243RHB	1.0 V / 1.2 V	1.6 A / 1.0 A / 0.8 A	1.2 V	
	TPS650244RHB	1.55 V / 1.6 V	0.8 A / 1.6 A / 0.8 A	1.2 V	
	TPS650245RHB	0.9 V / 1.1 V	1.0 A / 0.8 A / 0.8 A	1.1 V	

(1) For the most current package and ordering information, see [Mechanical, Packaging, and Orderable Information](#) or at www.ti.com.

(2) The RHB package is available in tape and reel. Add R suffix (TPS650240RHBR) to order quantities of 3000 parts per reel. Add T suffix (TPS650240RHBT) to order quantities of 250 parts per reel.

7 Pin Configuration and Functions

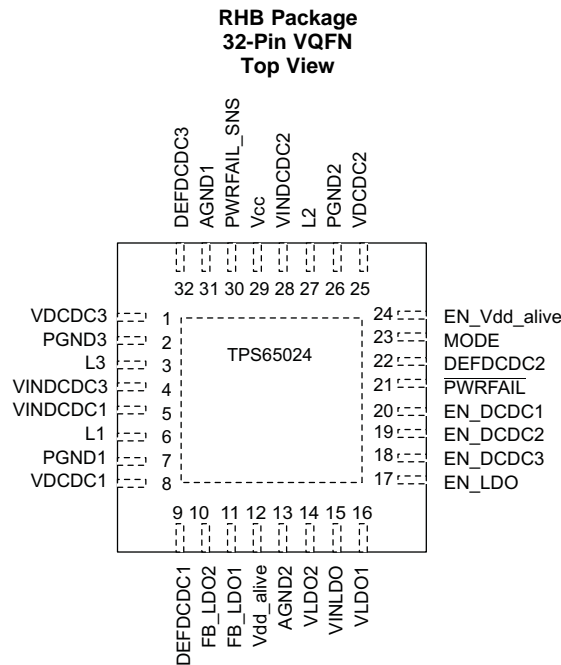

Pin Functions

PIN		I/O	DESCRIPTION
NAME	NO.		
SWITCHING REGULATOR SECTION			
AGND1	31	–	Analog ground connection. All analog ground pins are connected internally on the chip.
AGND2	13	–	Analog ground connection. All analog ground pins are connected internally on the chip.
DEFDCDC1	9	I	Input signal indicating default VDCDC1 voltage, 0 = 2.80 V, 1 = 3.3 V This pin can also be connected to a resistor divider between VDCDC1 and GND. In this case the output voltage of the DCDC1 converter can be set in a range from 0.6V to VINDCDC1
DEFDCDC2	22	I	Input signal indicating default VDCDC2 voltage, 0 = 1.8 V, 1 = 2.5 V This pin can also be connected to a resistor divider between VDCDC2 and GND. In this case the output voltage of the DCDC2 converter can be set in a range from 0.6V to VINDCDC2.
DEFDCDC3	32	I	Input signal indicating VDCDC3 voltage. TPS650240: 0 = 1.0 V, 1 = 1.3 V TPS650241: 0 = 0.9 V, 1 = 1.375 V TPS650242: 0 = 1.0 V, 1 = 1.5 V TPS650243: 0 = 1.0 V, 1 = 1.2 V TPS650244: 0 = 1.55 V, 1 = 1.6 V TPS650245: 0 = 0.9 V, 1 = 1.1 V
EN_DCDC1	20	I	VDCDC1 enable pin. A logic high enables the regulator, a logic low disables the regulator.
EN_DCDC2	19	I	VDCDC2 enable pin. A logic high enables the regulator, a logic low disables the regulator.
EN_DCDC3	18	I	VDCDC3 enable pin. A logic high enables the regulator, a logic low disables the regulator.
L1	6	–	Switch pin of VDCDC1 converter. The VDCDC1 inductor is connected here.
L2	27	–	Switch pin of VDCDC2 converter. The VDCDC2 inductor is connected here.
L3	3	–	Switch pin of VDCDC3 converter. The VDCDC3 inductor is connected here.
PGND1	7	–	Power ground for VDCDC1 converter
PGND2	26	–	Power ground for VDCDC2 converter
PGND3	2	–	Power ground for VDCDC3 converter
PowerPad	–	–	Connect the power pad to analog ground

Pin Functions (continued)

PIN		I/O	DESCRIPTION
NAME	NO.		
V _{CC}	29	I	Power supply for digital and analog circuitry of DCDC1, DCDC2, and DCDC3 DC-DC converters. This must be connected to the same voltage supply as VINDCDC3, VINDCDC1, and VINDCDC2.
VDCDC1	8	I	VDCDC1 feedback voltage sense input, connect directly to VDCDC1
VDCDC2	25	I	VDCDC2 feedback voltage sense input, connect directly to VDCDC2
VDCDC3	1	I	VDCDC3 feedback voltage sense input, connect directly to VDCDC3
VINDCDC1	5	I	Input voltage for VDCDC1 step-down converter. This must be connected to the same voltage supply as VINDCDC2, VINDCDC3, and V _{CC} .
VINDCDC2	28	I	Input voltage for VDCDC2 step-down converter. This must be connected to the same voltage supply as VINDCDC1, VINDCDC3, and V _{CC} .
VINDCDC3	4	I	Input voltage for VDCDC3 step-down converter. This must be connected to the same voltage supply as VINDCDC1, VINDCDC2, and V _{CC} .
LDO REGULATOR SECTION			
EN_LDO	17	I	Enable input for LDO1 and LDO2. Logic high enables the LDOs, logic low disables the LDOs.
EN_Vdd_alive	24	I	Enable input for Vdd_alive LDO. Logic high enables the LDO, logic low disables the LDO.
FB_LDO1	11	I	Feedback pin for LDO1
FB_LDO2	10	I	Feedback pin for LDO2
Vdd_alive	12	O	Output voltage for Vdd_alive
VINLDO	15	I	Input voltage for LDO1 and LDO2
VLDO1	16	O	Output voltage of LDO1
VLDO2	14	O	Output voltage of LDO2
CONTROL AND I²C SECTION			
MODE	23	I	Select between power safe mode and forced PWM mode for DCDC1, DCDC2, and DCDC3. In power safe mode PFM is used at light loads, PWM for higher loads. If PIN is set to high level, forced PWM mode is selected. If the pin has low level, then the device operates in power safe mode.
$\overline{\text{PWRFAIL}}$	21	O	Open-drain output. Active low when PWRFAIL comparator indicates low VBAT condition.
PWRFAIL_SNS	30	I	Input for the comparator driving the $\overline{\text{PWRFAIL}}$ output

8 Specifications

8.1 Absolute Maximum Ratings

over operating free-air temperature range (unless otherwise noted) ⁽¹⁾

	MIN	MAX	UNIT
Input voltage range on all pins except A/PGND, VLDO1, and VLDO2 pins, with respect to AGND	-0.3	7	V
Voltage range on pins VLDO1 and VLDO2 with respect to AGND	-0.3	3.6	V
Current at VINDCDC1, L1, PGND1, VINDCDC2, L2, PGND2, VINDCDC3, L3, PGND3		2000	mA
Peak current at all other pins		1000	mA
T _A Operating free-air temperature	-40	85	°C
T _J Maximum junction temperature		125	°C
Lead temperature 1.6 mm (1/16-inch) from case for 10 seconds		260	°C
T _{stg} Storage temperature	-65	150	°C

(1) Stresses beyond those listed under *Absolute Maximum Ratings* may cause permanent damage to the device. These are stress ratings only, which do not imply functional operation of the device at these or any other conditions beyond those indicated under *Recommended Operating Conditions*. Exposure to absolute-maximum-rated conditions for extended periods may affect device reliability.

8.2 ESD Ratings

		VALUE	UNIT
V _(ESD) Electrostatic discharge	Human-body model (HBM), per ANSI/ESDA/JEDEC JS-001 ⁽¹⁾	±2500	V
	Charged-device model (CDM), per JEDEC specification JESD22-C101 ⁽²⁾	±1500	

(1) JEDEC document JEP155 states that 500-V HBM allows safe manufacturing with a standard ESD control process.

(2) JEDEC document JEP157 states that 250-V CDM allows safe manufacturing with a standard ESD control process.

8.3 Recommended Operating Conditions

	MIN	NOM	MAX	UNIT
V _{INDCDC1} , V _{INDCDC2} , V _{INDCDC3} , V _{CC}	Input voltage range step-down converters		6	V
V _{DCDC1}	Output voltage range for VDCDC1 step-down converter ⁽¹⁾		V _{INDCDC1}	V
V _{DCDC2}	Output voltage range for mem step-down converter ⁽¹⁾		V _{INDCDC2}	V
V _{DCDC3}	Output voltage range for core step-down converter		1.5	V
V _{INLDO1} , V _{INLDO2}	Input voltage range for LDOs		6.5	V
V _{LDO1-2}	Output voltage range for LDOs		3.3	V
I _{OUTDCDC1}	Output current at L1		1600	mA
L1	Inductor at L1 ⁽²⁾		2.2	μH
C _{INDCDC1}	Input capacitor at V _{INDCDC1} ⁽²⁾		10	μF
C _{OUTDCDC1}	Output capacitor at V _{DCDC1} ⁽²⁾		22	μF
I _{OUTDCDC2}	Output current at L2		1600	mA
L2	Inductor at L2 ⁽²⁾		2.2	μH
C _{INDCDC2}	Input capacitor at V _{INDCDC2} ⁽²⁾		10	μF
C _{OUTDCDC2}	Output capacitor at V _{DCDC2} ⁽²⁾		22	μF
I _{OUTDCDC3}	Output current at L3		800	mA
L3	Inductor at L3 ⁽²⁾		2.2	μH
C _{INDCDC3}	Input capacitor at V _{INDCDC3} ⁽²⁾		10	μF
C _{OUTDCDC3}	Output capacitor at V _{DCDC3} ⁽²⁾		22	μF
C _{Vcc}	Input capacitor at V _{CC} ⁽²⁾		1	μF
C _{in1-2}	Input capacitor at VINLDO ⁽²⁾		1	μF
C _{OUT1-2}	Output capacitor at VLDO1, VLDO2 ⁽²⁾		2.2	μF

(1) When using an external resistor divider at DEFDCDC2, DEFDCDC1.

(2) See *Inductor Selection for the DC-DC Converters* for more information, for V_{out} > 2.85 V choose 3.3-μH inductor.

Recommended Operating Conditions (continued)

		MIN	NOM	MAX	UNIT
$I_{LDO1,2}$	Output current at VLDO1, VLDO2			200	mA
C_{VRTC}	Output capacitor at Vdd_alive ⁽²⁾	2.2			μF
I_{Vdd_alive}	Output current at Vdd_alive			30	mA
T_A	Operating ambient temperature	-40		85	°C
T_J	Operating junction temperature	-40		125	°C
R_{CC}	Resistor from VINDCDC3, VINDCDC2, VINDCDC1 to V _{CC} used for filtering ⁽³⁾		1	10	Ω

(3) Up to 2.5-mA can flow into V_{CC} when all 3 converters are running in PWM, this resistor causes the UVLO threshold to be shifted accordingly.

8.4 Thermal Information

THERMAL METRIC ⁽¹⁾		TPS650240	UNIT
		RHB (VQFN)	
		32 PINS	
$R_{\theta JA}$	Junction-to-ambient thermal resistance	32.2	°C/W
$R_{\theta JC(top)}$	Junction-to-case (top) thermal resistance	22.0	°C/W
$R_{\theta JB}$	Junction-to-board thermal resistance	6.2	°C/W
Ψ_{JT}	Junction-to-top characterization parameter	0.3	°C/W
Ψ_{JB}	Junction-to-board characterization parameter	6.1	°C/W
$R_{\theta JC(bot)}$	Junction-to-case (bottom) thermal resistance	1.7	°C/W

(1) For more information about traditional and new thermal metrics, see the *Semiconductor and IC Package Thermal Metrics* application report (SPRA953).

8.5 Electrical Characteristics: Control Signals and Supply Pins

VINDCDC1 = VINDCDC2 = VINDCDC3 = V_{CC} = VINLDO = 3.6 V, T_A = -40°C to +85°C, typical values are at T_A = 25°C (unless otherwise noted)

PARAMETER	TEST CONDITIONS		MIN	TYP ⁽¹⁾	MAX	UNIT	
CONTROL SIGNALS: EN_DCDC1, EN_DCDC2, EN_DCDC3, EN_LDO, MODE, EN_VDD_ALIVE							
V_{IH}	High level input voltage		1.45		V _{CC}	V	
V_{IL}	Low level input voltage		0		0.4	V	
I_H	Input bias current			0.01	0.1	μA	
SUPPLY PINS: V_{CC}, VINDCDC1, VINDCDC2, VINDCDC3							
$I_{(qPFM)}$	Operating quiescent current	V _{CC} = 3.6 V	PFM all 3 DCDC converters enabled, zero load and no switching, LDOs enabled		135	170	μA
			PFM all 3 DCDC converters enabled, zero load and no switching, LDO1, LDO2 = OFF, Vdd_alive = ON		75	100	
			PFM DCDC1 and DCDC2 converters enabled, zero load and no switching, LDO1, LDO2 = OFF, Vdd_alive = ON		55	80	
			PFM DCDC1 converter enabled, zero load and no switching, LDO1, LDO2 = OFF, Vdd_alive = ON		40	60	
$I_{VCC(PWM)}$	Current into V _{CC} ; PWM	V _{CC} = 3.6 V	All 3 DCDC converters enabled and running in PWM, LDOs off		2	mA	
			PWM DCDC1 and DCDC2 converters enabled and running in PWM, LDOs off		1.5		2.5
			PWM DCDC1 converter enabled and running in PWM, LDOs off		0.85		2

(1) Typical values are at T_A = 25°C

Electrical Characteristics: Control Signals and Supply Pins (continued)

VINDCDC1 = VINDCDC2 = VINDCDC3 = V_{CC} = VINLDO = 3.6 V, T_A = –40°C to +85°C, typical values are at T_A = 25°C (unless otherwise noted)

PARAMETER		TEST CONDITIONS	MIN	TYP ⁽¹⁾	MAX	UNIT
I _q	Quiescent current	V _{CC} = 3.6 V	All converters disabled, LDO1, LDO2 = OFF, Vdd_alive = OFF			μA
			All converters disabled, LDO1, LDO2 = OFF, Vdd_alive = ON			

8.6 Electrical Characteristics: VDCDC1 Step-Down Converter

VINDCDC1 = VINDCDC2 = VINDCDC3 = V_{CC} = VINLDO = 3.6 V, T_A = –40°C to +85°C, typical values are at T_A = 25°C (unless otherwise noted)

PARAMETER		TEST CONDITIONS	MIN	TYP ⁽¹⁾	MAX	UNIT
V _{VINDCDC1}	Input voltage range		2.5		6	V
I _O	Maximum output current for TPS650240, TPS650242, and TPS650245	V _O = 3.3 V	1000			mA
I _O	Maximum output current for TPS650241 and TPS650243	V _O = 3.3 V	1600			mA
I _O	Maximum output current for TPS650244	V _O = 3.3 V	800			mA
I _{SD}	Shutdown supply current in VINDCDC1	EN_DCDC1 = GND	0.1		1	μA
R _{DS(ON)}	P-channel MOSFET ON-resistance	VINDCDC1 = VGS = 3.6 V	125		261	mΩ
I _{LP}	P-channel leakage current	VINDCDC1 = 6 V			2	μA
R _{DS(ON)}	N-channel MOSFET ON-resistance	VINDCDC1 = VGS = 3.6 V	130		260	mΩ
I _{LN}	N-channel leakage current	V _{DS} = 6.0 V		7	10	μA
I _{LIMF}	Forward current limit (P- and N-channel) for TPS650244	2.5 V < V _{INMAIN} < 6.0 V	0.98	1.1	1.21	A
	Forward current limit (P- and N-channel) for TPS650240, TPS650242, and TPS650245	2.5 V < V _{INMAIN} < 6.0 V	1.15	1.3	1.39	A
	Forward current limit (P- and N-channel) for TPS650241 and TPS650243	2.5 V < V _{INMAIN} < 6.0 V	1.75	1.97	2.15	A
f _S	Oscillator frequency		1.95	2.25	2.55	MHz
VDCDC1	Fixed output voltage MODE = 0 (PWM/PFM)	VINDCDC1 = 3.3 V to 6 V; 0 mA ≤ I _O ≤ 1.6 A	2.80 V	–2%	2%	
			3.3 V	–2%	2%	
	Fixed output voltage MODE = 1 (PWM)	VINDCDC1 = 3.7 V to 6 V; 0 mA ≤ I _O ≤ 1.6 A	2.80 V	–1%	1%	
			3.3 V	–1%	1%	
Adjustable output voltage with resistor divider at DEFDCDC1; MODE = 0 (PWM/PFM)	VINDCDC1 = VDCDC1 + 0.4 V (min 2.5 V) to 6 V; 0 mA ≤ I _O ≤ 1.6 A	–2%		2%		
Adjustable output voltage with resistor divider at DEFDCDC1; MODE = 1 (PWM)	VINDCDC1 = VDCDC1 + 0.4 V (min 2.5 V) to 6 V; 0 mA ≤ I _O ≤ 1.6 A	–1%		1%		
	Line regulation	VINDCDC1 = VDCDC1 + 0.3 V (min 2.5 V) to 6 V; I _O = 10 mA		0%		V
	Load regulation	I _O = 10 mA to 1.6 A		0.25%		A
T _{SS}	Soft-start ramp time	VDCDC1 ramping from 5% to 95% of target value		750		μs
R(L1)	Internal resistance from L1 to GND			1		MΩ

(1) Typical values are at T_A = 25°C

8.7 Electrical Characteristics: VDCDC2 Step-Down Converter

VINDCDC1 = VINDCDC2 = VINDCDC3 = V_{CC} = VINLDO = 3.6V, T_A = –40°C to +85°C, typical values are at T_A = 25°C (unless otherwise noted)

PARAMETER		TEST CONDITIONS		MIN	TYP ⁽¹⁾	MAX	UNIT
V _{VINDCDC2}	Input voltage range			2.5		6	V
I _O	Maximum output current for TPS650240, TPS650242, and TPS650245	V _O = 2.5 V		800			mA
I _O	Maximum output current for TPS650241 and TPS650243	V _O = 2.5 V		1000			mA
I _O	Maximum output current for TPS650244	V _O = 2.5 V		1600			mA
I _{SD}	Shutdown supply current in VINDCDC2	EN_DCDC2 = GND			0.1	1	μA
R _{DS(ON)}	P-channel MOSFET ON-resistance	VINDCDC2 = V _{GS} = 3.6 V			140	300	mΩ
I _{LP}	P-channel leakage current	VINDCDC2 = 6 V				2	μA
R _{DS(ON)}	N-channel MOSFET ON-resistance	VINDCDC2 = V _{GS} = 3.6 V			150	297	mΩ
I _{LN}	N-channel leakage current	V _{DS} = 6 V			7	10	μA
I _{LIMF}	Forward current limit (P- and N-channel) for TPS650240, TPS650242, and TPS650245	2.5 V < VINDCDC2 < 6 V		1.05	1.16	1.29	A
I _{LIMF}	Forward current limit (P- and N-channel) for TPS650241 and TPS650243	2.5 V < VINDCDC2 < 6 V		1.22	1.35	1.5	A
I _{LIMF}	Forward current limit (P- and N-channel) for TPS650244	2.5 V < VINDCDC2 < 6 V		1.75	1.97	2.15	A
f _S	Oscillator frequency			1.95	2.25	2.55	MHz
VDCDC2	Fixed output voltage MODE = 0 (PWM/PFM)	VINDCDC2 = 2.5 V to 6 V; 0 mA ≤ I _O ≤ 1.6 A	1.8 V	–2%		2%	
		VINDCDC2 = 3.0 V to 6 V; 0 mA ≤ I _O ≤ 1.6 A	2.5 V	–2%		2%	
	Fixed output voltage MODE = 1 (PWM)	VINDCDC2 = 2.5 V to 6 V; 0 mA ≤ I _O ≤ 1.6 A	1.8 V	–2%		2%	
		VINDCDC2 = 3.0 V to 6 V; 0 mA ≤ I _O ≤ 1.6 A	2.5 V	–1%		1%	
	Adjustable output voltage with resistor divider at DEFDCDC2; MODE = 0 (PWM)	VINDCDC2 = VDCDC2 + 0.5 V (min 2.5 V) to 6 V; 0 mA ≤ I _O ≤ 1.6 A		–2%		2%	
	Adjustable output voltage with resistor divider at DEFDCDC2; MODE = 1 (PWM)	VINDCDC2 = VDCDC2 + 0.5 V (min 2.5 V) to 6 V; 0 mA ≤ I _O ≤ 1.6 A		–1%		1%	
	Line regulation	VINDCDC2 = VDCDC2 + 0.3 V (min 2.5 V) to 6 V; I _O = 10 mA			0%		V
	Load regulation	I _O = 10 mA to 1.6 A			0.25%		A
T _{SS}	Soft-start ramp time	VDCDC2 ramping from 5% to 95% of target value			750		μs
R(L2)	Internal resistance from L2 to GND				1		MΩ

(1) Typical values are at T_A = 25°C

8.8 Electrical Characteristics: VDCDC3 Step-Down Converter

V_{INDCDC1} = V_{INDCDC2} = V_{INDCDC3} = V_{CC} = V_{INLDO} = 3.6V, T_A = –40°C to +85°C, typical values are at T_A = 25°C (unless otherwise noted)

PARAMETER		TEST CONDITIONS	MIN	TYP ⁽¹⁾	MAX	UNIT
V _{INDCDC3}	Input voltage range		2.5		6	V
I _O	Maximum output current	V _O = 1.6 V	800			mA
I _{SD}	Shutdown supply current in V _{INDCDC3}	EN_DCDC3 = GND		0.1	1	μA
R _{DS(ON)}	P-channel MOSFET ON-resistance	V _{INDCDC3} = V _{GS} = 3.6 V		310	698	mΩ
I _{LP}	P-channel leakage current	V _{INDCDC3} = 6.0 V		0.1	2	μA
R _{DS(ON)}	N-channel MOSFET ON-resistance	V _{INDCDC3} = V _{GS} = 3.6 V		220	503	mΩ
I _{LN}	N-channel leakage current	V _{DS} = 6 V		7	10	μA
I _{LIMF}	Forward current limit (P- and N-channel)	2.5 V < V _{INDCDC3} < 6 V	1	1.2	1.4	A
f _S	Oscillator frequency		1.95	2.25	2.55	MHz
VDCDC3	Fixed output voltage MODE = 0 (PWM/PFM)	V _{INDCDC3} = 2.5 V to 6 V; 0 mA ≤ I _O ≤ 800 mA, V _O = 0.9 V to 1.6 V	-2%		2%	
	Fixed output voltage MODE = 1 (PWM)		-1%		1%	
	Line regulation	V _{INDCDC3} = VDCDC3 + 0.3 V (min. 2.5 V) to 6 V; I _O = 10 mA		0%		V
	Load regulation	I _O = 10 mA to 600 mA		0.25%		A
T _{SS}	Soft-start ramp time	VDCDC3 ramping from 5% to 95% of target value		750		μs
R(L3)	Internal resistance from L3 to GND			1		MΩ

(1) Typical values are at T_A = 25°C

8.9 Electrical Characteristics: General

VINDCDC1 = VINDCDC2 = VINDCDC3 = V_{CC} = VINLDO = 3.6V, T_A = –40°C to +85°C, typical values are at T_A = 25°C (unless otherwise noted)

PARAMETER		TEST CONDITIONS	MIN	TYP ⁽¹⁾	MAX	UNIT
VLDO1 AND VLDO2 LOW DROPOUT REGULATORS						
I _(q)	Operating quiescent current	Current per LDO into VINLDO		16	30	μA
I _(SD)	Shutdown current	Total current into VINLDO, VLDO = 0 V		0.6	2	μA
V _{INLDO}	Input voltage range for LDO1, LDO2		1.5		6.5	V
V _{LDO1}	LDO1 output voltage range		1		3.3	V
V _{LDO2}	LDO2 output voltage range		1		3.3	V
V _{Fb}	LDO1 and LDO2 feedback voltage	See ⁽²⁾		1		V
I _O	Maximum output current for LDO1, LDO2	V _{in} = 1.8 V, V _o = 1.3 V	200			mA
I _O	Maximum output current for LDO1, LDO2	V _{in} = 1.5 V; V _o = 1.3 V		120		mA
I _{SC}	LDO1 & LDO2 short circuit current limit	V _{LDO1} = GND, V _{LDO2} = GND			400	mA
	Minimum voltage drop at LDO1, LDO2	I _O = 50 mA, VINLDO = 1.8 V			120	mV
	Minimum voltage drop at LDO1, LDO2	I _O = 50 mA, VINLDO = 1.5 V		65	150	mV
	Minimum voltage drop at LDO1, LDO2	I _O = 200 mA, VINLDO = 1.8 V			300	mV
	Output voltage accuracy for LDO1, LDO2	I _O = 10 mA	–2%		1%	
	Line regulation for LDO1, LDO2	V _{INLDO1,2} = V _{LDO1,2} + 0.5 V (min. 2.5 V) to 6.5 V, I _O = 10 mA	–1%		1%	
	Load regulation for LDO1, LDO2	I _O = 0 mA to 200 mA	–1%		1%	
	Regulation time for LDO1, LDO2	Load change from 10% to 90%		10		μs
Vdd_alive LOW DROPOUT REGULATOR						
V _{dd_alive}	V _{dd_alive} LDO output voltage, TPS650240 to TPS650244	I _O = 0 mA		1.2		V
	V _{dd_alive} LDO output voltage, TPS650245	I _O = 0 mA		1.1		
I _O	Output current for V _{dd_alive}				30	mA
I _{SC}	V _{dd_alive} short circuit current limit	V _{dd_alive} = GND			100	mA
	Output voltage accuracy for V _{dd_alive}	I _O = 0 mA	–1%		1%	
	Line regulation for V _{dd_alive}	V _{CC} = V _{dd_alive} + 0.5 V to 6.5 V, I _O = 0 mA	–1%		1%	
	Regulation time for V _{dd_alive}	Load change from 10% to 90%		10		μs
ANALOGIC SIGNALS DEFDCDC1, DEFDCDC2, DEFDCDC3						
V _{IH}	High level input voltage		1.3		V _{CC}	V
V _{IL}	Low level input voltage		0		0.1	V
I _H	Input bias current			0.001	0.05	μA
THERMAL SHUTDOWN						
T _{SD}	Thermal shutdown	Increasing junction temperature		160		°C
	Thermal shutdown hysteresis	Decreasing junction temperature		20		°C
INTERNAL UNDER VOLTAGE LOCK OUT						
UVLO	Internal UVLO	V _{CC} falling	–3%	2.35	3%	V
V _{UVLO_HYST}	Internal UVLO comparator hysteresis			120		mV
VOLTAGE DETECTOR COMPARATOR						
PWRFAIL_SNS	Comparator threshold	Falling threshold	–2%	1	2%	V
	Hysteresis		40	50	60	mV
	Propagation delay	25 mV overdrive			10	μs
V _{OL}	Power fail output low voltage	I _{OL} = 5 mA			0.3	V

(1) Typical values are at T_A = 25°C

(2) If the feedback voltage is forced higher than above 1.2 V, a leakage current into the feedback pin may occur.

8.10 Typical Characteristics

Table 1. Table of Graphs

			FIGURE
η	Efficiency VDCDC1	vs Load current PWM/PFM; $V_O = 3.3$ V	Figure 1
η	Efficiency VDCDC1	vs Load current PWM; $V_O = 3.3$ V	Figure 2
η	Efficiency VDCDC2	vs Load current PWM/PFM; $V_O = 1.8$ V	Figure 3
η	Efficiency VDCDC2	vs Load current PWM; $V_O = 1.8$ V	Figure 4
η	Efficiency VDCDC3	vs Load current PWM/PFM; $V_O = 1.3$ V	Figure 5
η	Efficiency VDCDC3	vs Load current PWM; $V_O = 1.3$ V	Figure 6
	Line transient response VDCDC1		Figure 7
	Line transient response VDCDC2		Figure 8
	Line transient response VDCDC3		Figure 9
	Load transient response VDCDC1		Figure 10
	Load transient response VDCDC2		Figure 11
	Load transient response VDCDC3		Figure 12
	Output voltage ripple DCDC2; PFM mode		Figure 13
	Output voltage ripple DCDC2; PWM mode		Figure 14
	Load regulation for Vdd_alive		Figure 15
	Start-up VDCDC1 to VDCDC3		Figure 16
	Start-up LDO1 and LDO2		Figure 17

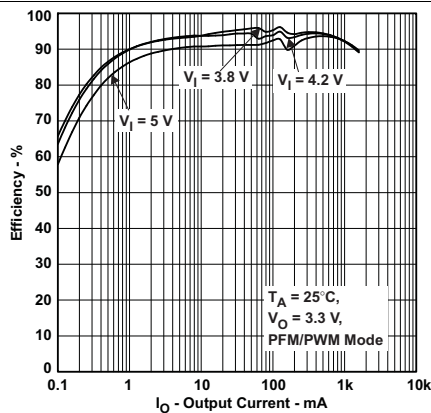

Figure 1. DCDC1: Efficiency vs Output Current

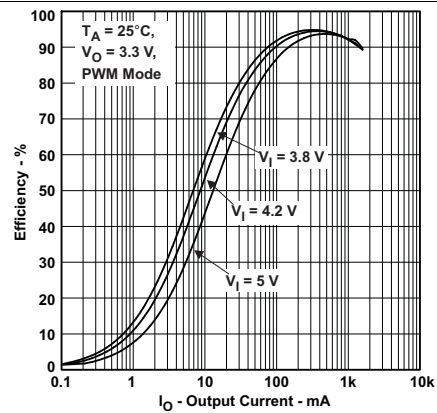

Figure 2. DCDC1: Efficiency vs Output Current

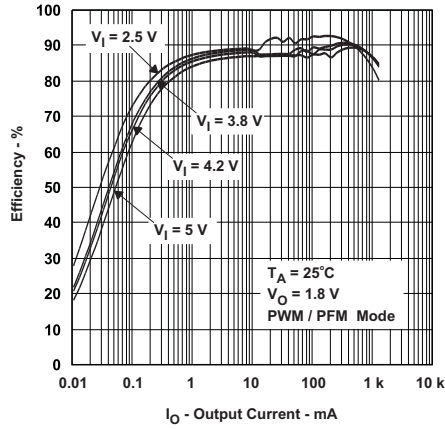

Figure 3. DCDC2: Efficiency vs Output Current

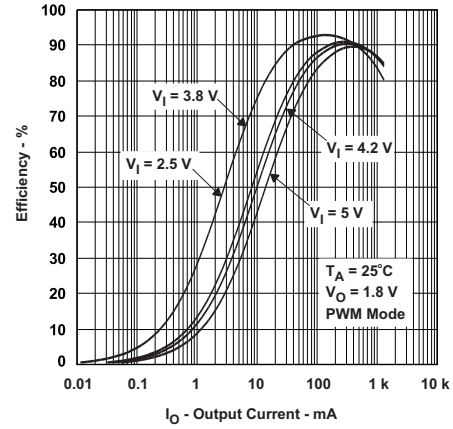

Figure 4. DCDC2: Efficiency vs Output Current

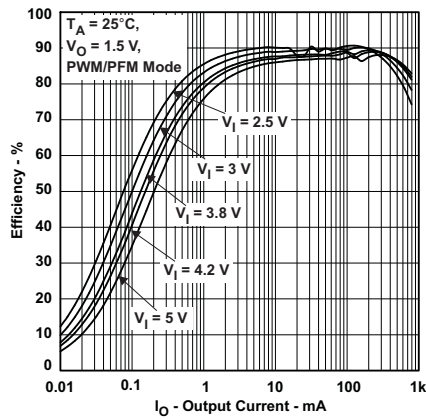

Figure 5. DCDC3: Efficiency vs Output Current

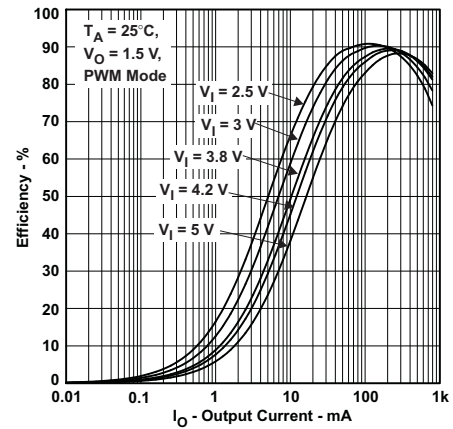

Figure 6. DCDC3: Efficiency vs Output Current

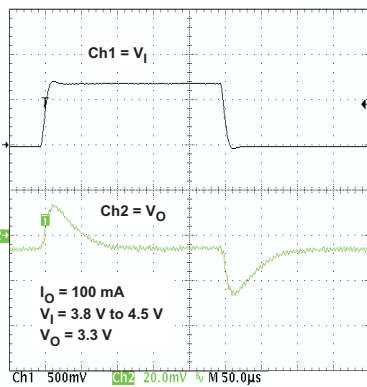

Figure 7. VDCC1 Line Transient Response

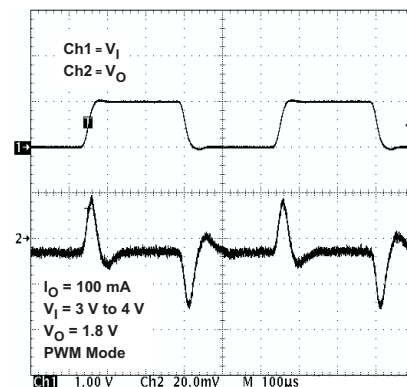

Figure 8. VDCC2 Line Transient Response

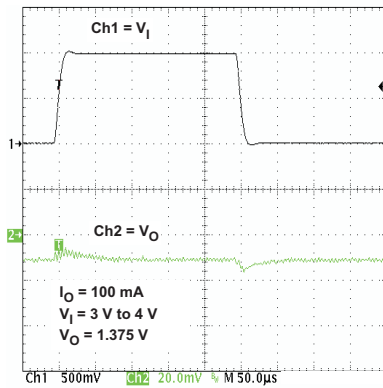

Figure 9. VDCDC3 Line Transient Response

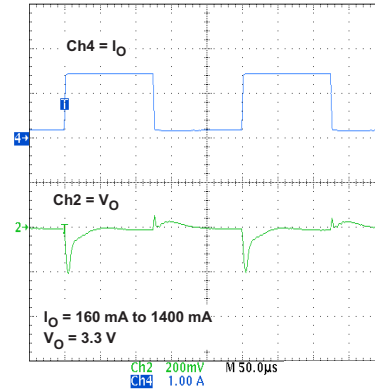

Figure 10. VDCDC1 Load Transient Response

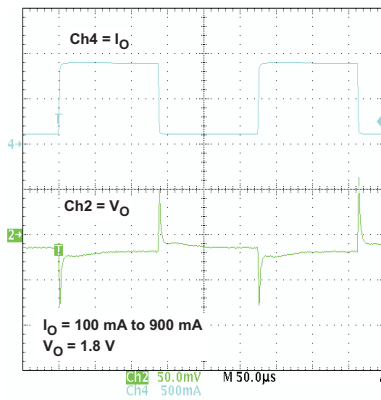

Figure 11. VDCDC2 Load Transient Response

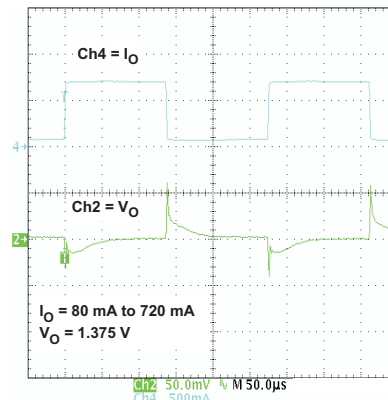

Figure 12. VDCDC3 Load Transient Response

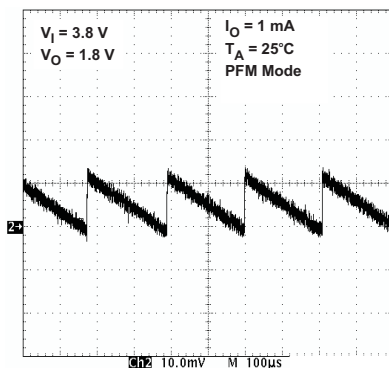

Figure 13. VDCDC2 Output Voltage Ripple, PFM Mode

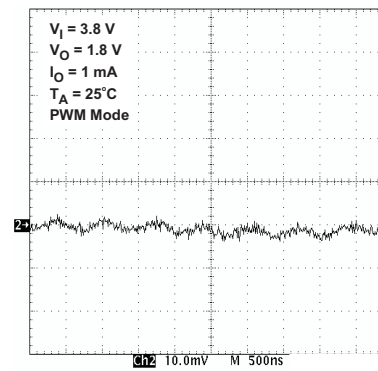

Figure 14. VDCDC2 Output Voltage Ripple, PWM Mode

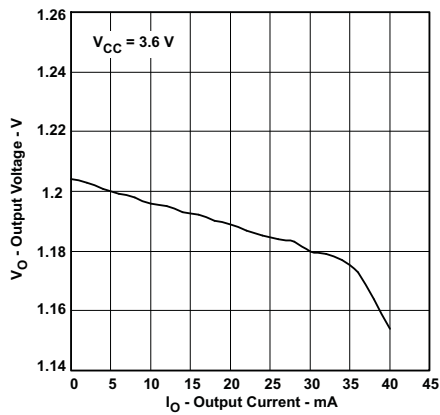

Figure 15. VDD_ALIVE Output Voltage vs Output Current

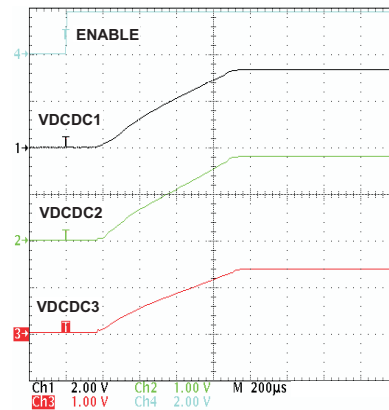

Figure 16. Startup VDCDC1, VDCDC2, VDCDC3

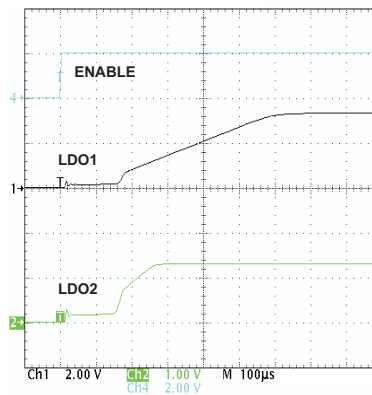

Figure 17. Start-Up LDO1 AND LDO2

9 Detailed Description

9.1 Overview

The TPS65024x are integrated power management ICs that contain three highly efficient step-down DC–DC converters, two 200-mA LDOs, and one 30-mA LDO. Capable of using one Li-Ion or Li-Polymer cell as the input voltage source, the TPS65024x family can support various battery-powered applications for a variety of voltages. Each TPS65024x device uses predefined output voltages, differentiated by the default output voltages defined for DCDC3. The output voltages of the 200-mA LDOs and two of the step-down converters are the same for all devices, and may be adjusted through external feedback resistors to operate outside of their predefined default values. The third step-down converter, DCDC3, uses DEFDCDC3 slightly differently than the other two converters, and as such requires an alternative method for adjusting the output voltages.

9.2 Functional Block Diagram

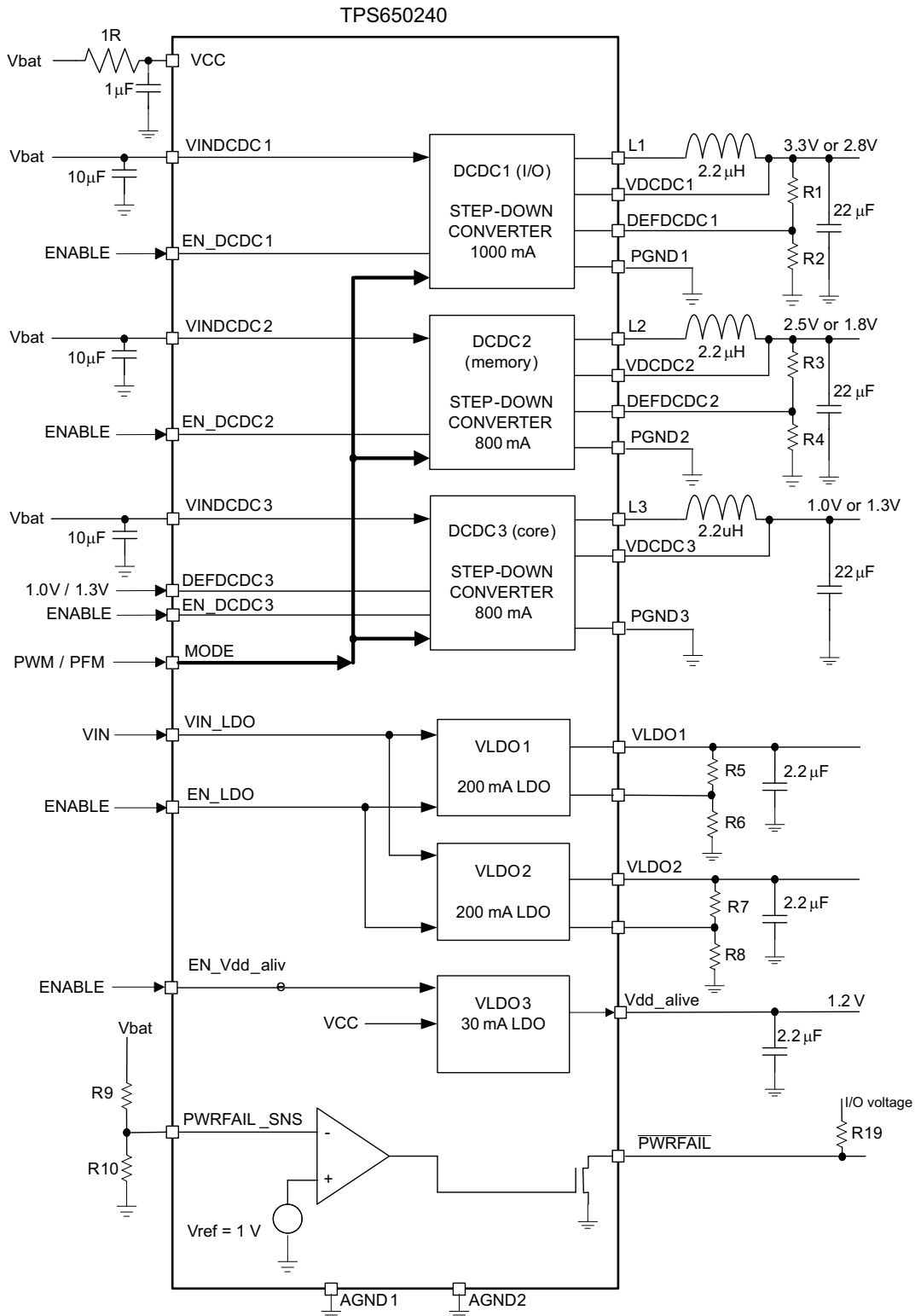

9.3 Feature Description

9.3.1 Step-Down Converters, VDCDC1, VDCDC2 and VDCDC3

The TPS65024x devices incorporate three synchronous step-down converters operating typically at 2.25-MHz fixed-frequency pulse width modulation (PWM) for moderate to heavy-load currents. At light-load currents the converters automatically enter power save mode and operate with pulse frequency modulation (PFM). The maximum supported load currents for VDCDC1 and VDCDC2 are device specific, unlike VDCDC3 which does not have the capability to exceed an 800-mA output.

The converter output voltages can be programmed through the DEFDCDC1, DEFDCDC2, and DEFDCDC3 pins. The pins can often be connected to GND, V_{CC} , or to a resistor divider between the output voltage and GND.

The VDCDC1 converter defaults to 2.80 V or 3.3 V depending on the DEFDCDC1 configuration pin, if DEFDCDC1 is tied to ground the default is 2.80 V, if it is tied to V_{CC} the default is 3.3 V. When the DEFDCDC1 pin is connected to a resistor divider, the output voltage can be set in the range of 0.6 V to $V_{INDCDC1}$ V. Reference the [Output Voltage Selection](#) section for details on setting the output voltage range.

The VDCDC2 converter defaults to 1.8 V or 2.5 V depending on the DEFDCDC2 configuration pin, if DEFDCDC2 is tied to ground the default is 1.8 V, if it is tied to V_{CC} the default is 2.5 V. When the DEFDCDC2 pin is connected to a resistor divider, the output voltage can be set in the range of 0.6 V to $V_{INDCDC2}$ V.

The VDCDC3 converter defaults to 1.0 V or 1.3 V for the TPS650240 depending on the DEFDCDC3 configuration pin, if DEFDCDC3 is tied to ground the default is 1.0 V, if it is tied to V_{CC} the default is 1.3 V. The DEFDCDC3 pin cannot be connected to a resistor divider. In opposition to DEFDCDC1 and DEFDCDC2, the DEFDCDC3 pin can be used to change the core voltage during operation by changing its logic level from HIGH to LOW or vice versa. TPS650241 to TPS650245 allow different voltages for the VDCDC3 converter. Reference the [Voltage Options](#) section for the TPS650240, TPS650241, TPS650242, TPS650243, TPS650244, and TPS650245 default voltage options.

During PWM operation the converters use a unique fast response voltage mode controller scheme with input voltage feedforward to achieve good line and load regulation allowing the use of small ceramic input and output capacitors. At the beginning of each clock cycle initiated by the clock signal, the P-channel MOSFET switch is turned on and the inductor current ramps up until the comparator trips and the control logic turns off the switch. The current limit comparator also turns off the switch in case the current limit of the P-channel switch is exceeded. After the adaptive dead-time used to prevent shoot through current, the N-channel MOSFET rectifier is turned on and the inductor current ramps down. The next cycle is initiated by the clock signal again turning off the N-channel rectifier and turning on the P-channel switch.

The three DC–DC converters operate synchronized to each other, with the VDCDC1 converter as the master. A 180° phase shift between the VDCDC1 switch turn on and the VDCDC2 and a further 90° shift to the VDCDC3 switch turn on decreases the input RMS current and smaller input capacitors can be used. This is optimized for a typical application where the VDCDC1 converter regulates a Li-Ion battery voltage of 3.7 V to 3.3 V, the VDCDC2 converter from 3.7 V to 2.5 V and the VDCDC3 converter from 3.7 V to 1.5 V.

9.4 Device Functional Modes

9.4.1 Power Save Mode Operation

As the load current decreases, the converters enter power save mode operation. During power save mode the converters operate in a burst mode (PFM mode) with a frequency between 1.125 MHz and 2.25 MHz for one burst cycle. However, the frequency between different burst cycles depends on the actual load current and is typically far less than the switching frequency, with a minimum quiescent current to maintain high efficiency.

To optimize the converter efficiency at light load, the average current is monitored, and if in PWM mode, the inductor current remains below a certain threshold before the device enters power save mode. The typical threshold to enter power save mode can be calculated in [Equation 1](#), [Equation 2](#), and [Equation 3](#):

$$I_{\text{PFMDCDC1enter}} = \frac{V_{\text{INDCDC 1}}}{24\Omega} \quad (1)$$

$$I_{\text{PFMDCDC2enter}} = \frac{V_{\text{INDCDC 2}}}{26\Omega} \quad (2)$$

$$I_{\text{PFMDCDC3leave}} = \frac{V_{\text{INDCDC 3}}}{39\Omega} \quad (3)$$

During power save mode the output voltage is monitored with a comparator and by maximum skip burst width. As the output voltage falls below the threshold, set to the nominal V_O , the P-channel switch turns on and the converter effectively delivers a constant current as defined in [Equation 4](#), [Equation 5](#), and [Equation 6](#).

$$I_{\text{PFMDCDC1leave}} = \frac{V_{\text{INDCDC 1}}}{18\Omega} \quad (4)$$

$$I_{\text{PFMDCDC2leave}} = \frac{V_{\text{INDCDC 2}}}{20\Omega} \quad (5)$$

$$I_{\text{PFMDCDC3enter}} = \frac{V_{\text{INDCDC 3}}}{29\Omega} \quad (6)$$

If the load is below the delivered current then the output voltage rises until the same threshold is crossed in the other direction. All switching activity ceases, reducing the quiescent current to a minimum until the output voltage has again dropped below the threshold. The power save mode is exited, and the converter returns to PWM mode if either of the following conditions are met:

1. The output voltage drops 2% below the nominal V_O due to increased load current
2. The PFM burst time exceeds $16 \times 1 / f_s$ (7.1 μs typical)

These control methods reduce the quiescent current to typically 14 μA per converter and the switching activity to a minimum thus achieving the highest converter efficiency. Setting the comparator thresholds at the nominal output voltage at light-load current results in a very low output voltage ripple. The ripple depends on the comparator delay and the size of the output capacitor; increasing capacitor values makes the output ripple tend to zero. Power save mode can be disabled by pulling the MODE pin high. This forces all DC–DC converters into fixed-frequency PWM mode.

9.4.2 Soft-Start

Each of the three converters has an internal soft-start circuit that limits the inrush current during start-up. The soft-start is realized by using a very low current to initially charge the internal compensation capacitor. The soft-start time is typically 750 μs if the output voltage ramps from 5% to 95% of the final target value. If the output is already precharged to some voltage when the converter is enabled, then this time is reduced proportionally. There is a short delay of typically 170 μs between the converter being enabled and switching activity actually starting. This is to allow the converter to bias itself properly, to recognize if the output is precharged, and if so, to prevent discharging of the output while the internal soft-start ramp catches up with the output voltage.

9.4.3 100% Duty Cycle Low-Dropout Operation

The TPS65024x converters offer a low input-to-output voltage difference while still maintaining operation with the use of the 100% duty cycle mode. In this mode the P-channel switch is constantly turned on. This is particularly useful in battery-powered applications to achieve the longest operation time by taking full advantage of the whole battery voltage range. The minimum input voltage required to maintain DC regulation depends on the load current and output voltage and can be calculated in [Equation 7](#).

Device Functional Modes (continued)

$$V_{in_min} = V_{out_min} + I_{out_max} \times (R_{DSon_max} + R_L)$$

where

- I_{out_max} = Maximum load current (note: ripple current in the inductor is zero under these conditions)
 - R_{DSon_max} = Maximum P-channel switch R_{DSon}
 - R_L = DC resistance of the inductor
 - V_{out_min} = Nominal output voltage minus 2% tolerance limit
- (7)

9.4.4 Low-Dropout Voltage Regulators

The low-dropout voltage regulators are designed to operate well with low-value ceramic input and output capacitors. They operate with input voltages down to 1.5 V. The LDOs offer a maximum dropout voltage of 300 mV at the rated output current. Each LDO sports a current limit feature. Both LDOs are enabled by the EN_LDO pin. The LDOs also have reverse conduction prevention. This allows the possibility to connect external regulators in parallel in systems with a backup battery. The TPS65024x step-down and LDO voltage regulators automatically power down when the V_{CC} voltage drops below the UVLO threshold or when the junction temperature rises above 160°C.

9.4.5 Undervoltage Lockout

The undervoltage lockout circuit for the five regulators on the TPS65024x prevents the device from malfunctioning at low input voltages and from excessive discharge of the battery. It disables the converters and LDOs. The UVLO circuit monitors the V_{CC} pin; the threshold is set internally to 2.35 V with 5% (120 mV) hysteresis.

NOTE

When any of the DC–DC converters are running there is an input current at the V_{CC} pin, which can be up to 3 mA when all three converters are running in PWM mode. Take this current into consideration if an external RC filter is used at the V_{CC} pin to remove switching noise from the TPS65024x internal analog circuitry supply.

See [V_{CC} Filter](#) for details on the external RC filter.

9.4.6 Power-Up Sequencing

The TPS65024x power-up sequencing is designed to be entirely flexible and customer driven; this is achieved simply by providing separate enable pins for each switch-mode converter and a common enable signal for LDO1 and LDO2. The relevant control pins are described in [Table 2](#).

Table 2. Control Pins for DCDC Converters

PIN NAME	INPUT/ OUTPUT	FUNCTION
DEFDCDC3	I	Defines the default voltage of the VDCDC3 switching converter. See Table 3 for details.
DEFDCDC2	I	Defines the default voltage of the VDCDC2 switching converter. DEFDCDC2 = 0 defaults VDCDC2 to 1.8 V, DEFDCDC2 = V_{CC} defaults VDCDC2 to 2.5 V.
DEFDCDC1	I	Defines the default voltage of the VDCDC1 switching converter. DEFDCDC1 = 0 defaults VDCDC1 to 2.80 V, DEFDCDC1 = V_{CC} defaults VDCDC1 to 3.3 V.
EN_DCDC3	I	Set EN_DCDC3 = 0 to disable or EN_DCDC3 = 1 to enable the VDCDC3 converter
EN_DCDC2	I	Set EN_DCDC2 = 0 to disable or EN_DCDC2 = 1 to enable the VDCDC2 converter
EN_DCDC1	I	Set EN_DCDC1 = 0 to disable or EN_DCDC1 = 1 to enable the VDCDC1 converter

9.4.7 PWRFAIL

The PWRFAIL signal is generated by a voltage detector at the PWRFAIL_SNS input. The input signal is compared to a 1-V threshold (falling edge) with 5% (50 mV) hysteresis. PWRFAIL is an open-drain output which is actively low when the input voltage at PWRFAIL_SNS is below the threshold.

10 Application and Implementation

NOTE

Information in the following applications sections is not part of the TI component specification, and TI does not warrant its accuracy or completeness. TI's customers are responsible for determining suitability of components for their purposes. Customers should validate and test their design implementation to confirm system functionality.

10.1 Application Information

10.1.1 Output Voltage Selection

The DEFDCDC1, DEFDCDC2, and DEFDCDC3 pins are used to set the output voltage for each step-down converter. See [Table 3](#) for the default voltages if the pins are pulled to GND or to V_{CC} .

Table 3. Voltage Options

PIN		LEVEL	DEFAULT OUTPUT VOLTAGE
DEFDCDC1	All versions	V_{CC}	3.3 V
		GND	2.80 V
DEFDCDC2	All versions	V_{CC}	2.5 V
		GND	1.8 V
DEFDCDC3	TPS650240	V_{CC}	1.3 V
		GND	1.0 V
	TPS650241	V_{CC}	1.375 V
		GND	0.9 V
	TPS650242	V_{CC}	1.5 V
		GND	1.0 V
	TPS650243	V_{CC}	1.2 V
		GND	1.0 V
	TPS650244	V_{CC}	1.6 V
		GND	1.55 V
	TPS650245	V_{CC}	1.1 V
		GND	0.9 V

If a different voltage is needed, an external resistor divider can be added to the DEFDCDC1 or DEFDCDC2 pin as shown in [Figure 18](#).

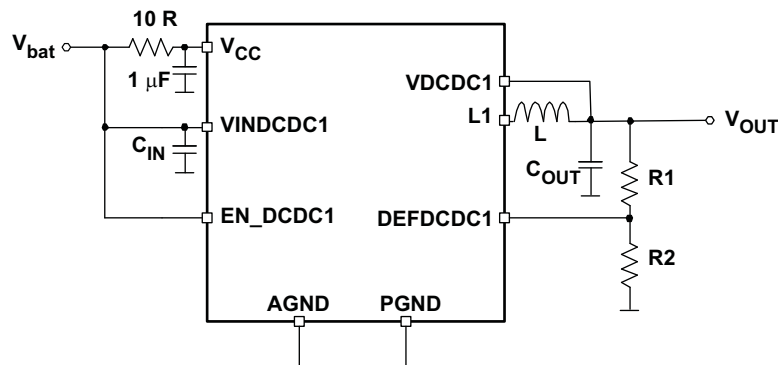

Figure 18. External Resistor Divider Diagram

When a resistor divider is connected to DEFDCDC1 or DEFDCDC2, the output voltage can be set from 0.6 V up to the input voltage V_{bat} . The total resistance ($R1 + R2$) of the voltage divider must be kept in the 1-M Ω range to maintain a high efficiency at light load. Detailed calculations for selecting these resistance values are presented in [Equation 8](#) and [Equation 9](#), where $V_{DEFDCDCx} = 0.6$ V.

$$V_{OUT} = V_{DEFDCDCx} \times \frac{R1 + R2}{R2} \quad (8)$$

$$R1 = R2 \left(\frac{V_{OUT}}{V_{DEFDCDCx}} \right) - R2 \quad (9)$$

10.1.2 Voltage Change on VDCDC3

The output voltage of VDCDC3 can be changed during operation from, for example, 1.0 V to 1.3 V (TPS650240), and back. While the output voltage at VDCDC1 and VDCDC2 is fixed after the device exits undervoltage lockout (UVLO), the status of the DEFDCDC3 pin is sensed during operation and the voltage is changed as soon as the logic level on this pin changes from low to high or vice versa. Therefore it is not possible to connect a resistor divider to DEFDCDC3 and set a voltage different from the predefined voltages.

10.1.3 Vdd_alive Output

The Vdd_alive LDO is typically connected to a logic input of an external device or application processor, and is capable of providing an output voltage of 1.2 V at 30 mA. For the TPS650245, the output voltage for vdd_alive is set to 1.1 V. TI recommends adding a capacitor of 2.2 μ F minimum to the Vdd_alive pin. The LDO can be disabled by pulling the EN_Vdd_alive pin to GND.

10.1.4 LDO1 and LDO2

The LDOs in the TPS65024x are general-purpose LDOs which are stable using ceramics capacitors. The minimum output capacitance required is 2.2 μ F. The LDOs output voltage can be changed to different voltages between 1.0 V and V_{in} using an external resistor divider. Therefore they can also be used as general-purpose LDOs in the application. The supply voltage for the LDOs needs to be connected to the VINLDO pin, giving the flexibility to connect the lowest voltage available in the system and therefore providing the highest efficiency.

The total resistance ($R5 + R6$) of the voltage divider must be kept in the 1-M Ω range to maintain high efficiency at light load. Detailed calculations for selecting these resistance values are presented in [Equation 10](#) and [Equation 11](#), where $V_{FBLDOx} = 1.0$ V.

$$V_{OUT} = V_{FBLDOx} \times \frac{R5 + R6}{R6} \quad (10)$$

$$R5 = R6 \times \left(\frac{V_{OUT}}{V_{FBLDOx}} \right) - R6 \quad (11)$$

10.1.5 V_{CC} Filter

An RC filter connected at the V_{CC} input is recommended to prevent noise from entering the internal supply used for the bandgap and other analog circuitry. A typical value of 1 Ω and 1 μ F is used to filter the switching spikes, generated by the DC–DC converters. A larger resistor than 10 Ω must not be used because the current into V_{CC} of up to 2.5 mA causes a voltage drop at the resistor causing the undervoltage lockout circuitry connected at V_{CC} internally to switch off too early.

10.2 Typical Applications

10.2.1 Typical Configuration for the Samsung Processor S3C6400-533MHz

The typical configuration for the Samsung processor S3C6400-533-MHz is shown in Figure 19. This application uses only the default output values for the step-down converters, specifying regulation targets with high and low logic on the DEFDCDCx pins.

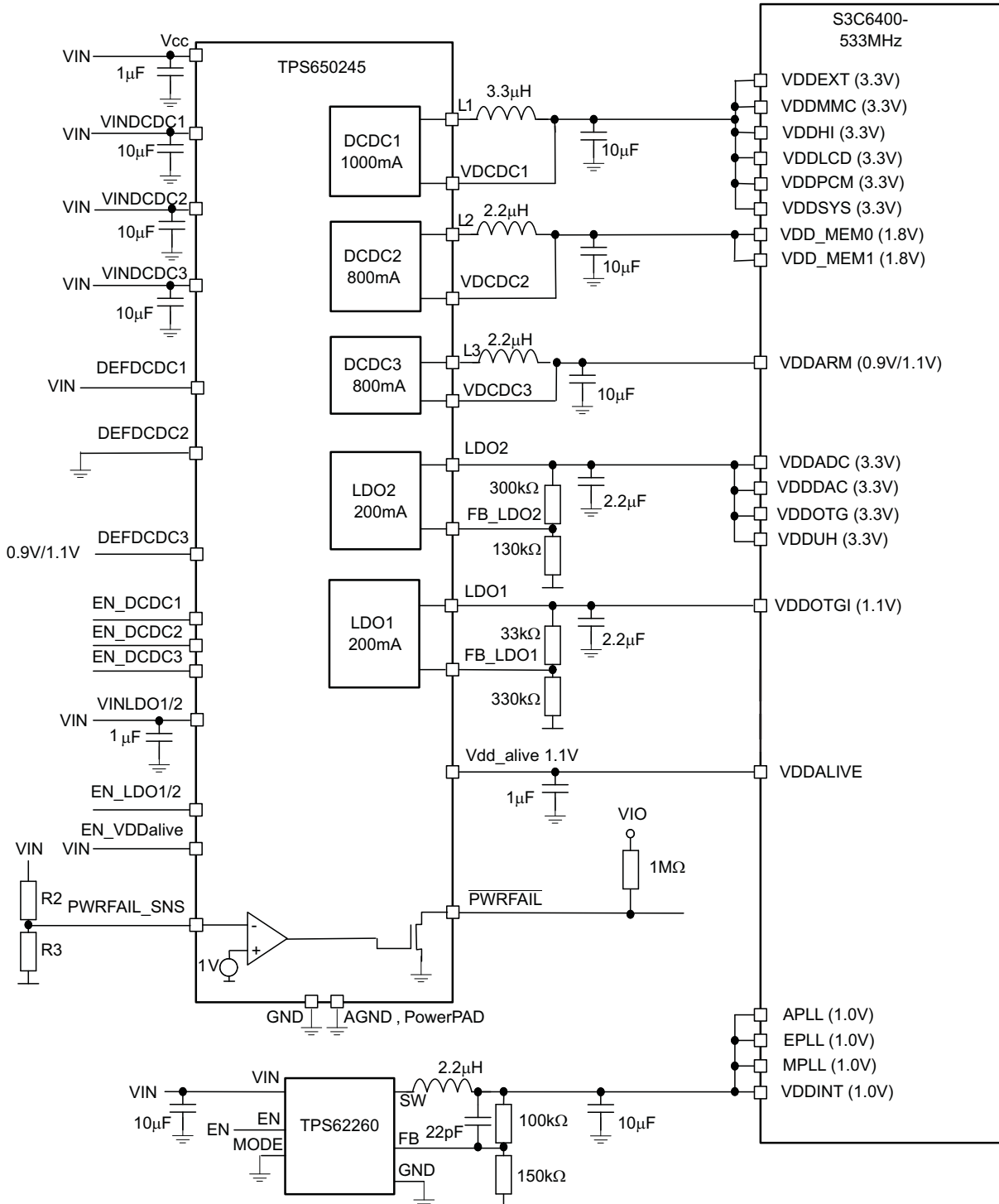

Figure 19. Samsung Processor Configuration

Typical Applications (continued)

10.2.1.1 Design Requirements

Each step-down converter requires an input decoupling capacitor, an output inductor, and an output filter capacitor. Desired output voltages must be configured through appropriate DEFDCDCx voltages, and all components must be selected to handle the maximum output currents, as well as any transient or ripple specifications that may be required for the expected loads.

The LDOs must have a decoupling capacitor on the input voltage pin, and a dedicated filter capacitor on each LDO output.

10.2.1.2 Detailed Design Procedure

10.2.1.2.1 Inductor Selection for the DC-DC Converters

The three converters operate with 2.2- μ H output inductors. Larger or smaller inductor values can be used to optimize performance of the device for specific conditions. The selected inductor has to be rated for its DC resistance and saturation current. The DC resistance of the inductor influences directly the efficiency of the converter. Therefore, an inductor with the lowest DC resistance must be selected for the highest efficiency.

For a fast transient response, a 2.2- μ H inductor in combination with a 22- μ F output capacitor is recommended. For an output voltage above 2.8 V, an inductor value of 3.3 μ H minimum is required. Lower values result in an increased output voltage ripple in PFM mode. The minimum inductor value is 1.5 μ H, but an output capacitor of 22 μ F minimum is needed in this case.

Equation 12 calculates the maximum inductor current under static load conditions. The saturation current of the inductor must be rated higher than the maximum inductor current as calculated with Equation 12. This is recommended because during heavy-load transient, the inductor current rises above the calculated value.

$$\Delta I_L = V_{out} \times \frac{1 - \frac{V_{out}}{V_{in}}}{L \times f} \quad I_{Lmax} = I_{outmax} + \frac{\Delta I_L}{2}$$

where

- f = Switching frequency (2.25 MHz typical)
- L = Inductor value
- ΔI_L = Peak-to-peak inductor ripple current
- I_{Lmax} = Maximum inductor current

(12)

The highest inductor current occurs at maximum V_{in} .

Open-core inductors have a soft saturation characteristic and they can usually handle higher inductor currents versus a comparable shielded inductor.

A more conservative approach is to select the inductor current rating just for the maximum switch current of the corresponding converter. Consideration must be given to the difference in the core material from inductor to inductor which has an impact on efficiency especially at high switching frequencies.

10.2.1.2.2 Output Capacitor Selection

The advanced fast response voltage mode control scheme of the inductive converters implemented in the TPS65024x allows the use of small ceramic capacitors with a typical value of 10 μ F for each converter, without having large output voltage under and overshoots during heavy load transients. Ceramic capacitors having low ESR values have the lowest output voltage ripple and are recommended.

If ceramic output capacitors are used, the capacitor RMS ripple current rating will always meet the application requirements. For completeness, the RMS ripple current is calculated as Equation 13:

$$I_{RMSout} = V_{out} \times \frac{1 - \frac{V_{out}}{V_{in}}}{L \times f} \times \frac{1}{2 \times \sqrt{3}}$$

(13)

At nominal load current the inductive converters operate in PWM mode and the overall output voltage ripple is the sum of the voltage spike caused by the output capacitor ESR plus the voltage ripple caused by charging and discharging the output capacitor:

Typical Applications (continued)

$$\Delta V_{out} = V_{out} \times \frac{1 - \frac{V_{out}}{V_{in}}}{L \times f} \times \left(\frac{1}{8 \times C_{out} \times f} + ESR \right)$$

where

- the highest output voltage ripple occurs at the highest input voltage, V_{in} (14)

At light-load currents the converters operate in power save mode and output voltage ripple is dependent on the output capacitor value. The output voltage ripple is set by the internal comparator delay and the external capacitor. Typical output voltage ripple is less than 1% of the nominal output voltage.

10.2.1.2.3 Input Capacitor Selection

Because of the nature of the buck converter having a pulsating input current, a low ESR input capacitor is required for best input voltage filtering and minimizing interference with other circuits caused by high input voltage spikes. Each DC–DC converter requires a 10- μ F ceramic input capacitor on its input pin VINDCDCx. The input capacitor can be increased without any limit for better input voltage filtering. The V_{CC} pin must be separated from the input for the DC–DC converters. A filter resistor of up to 10 Ω and a 1- μ F capacitor must be used for decoupling the V_{CC} pin from switching noise.

NOTE

The filter resistor may affect the UVLO threshold since up to 3 mA can flow through this resistor into the V_{CC} pin when all converters are running in PWM mode.

10.2.1.3 Application Curves

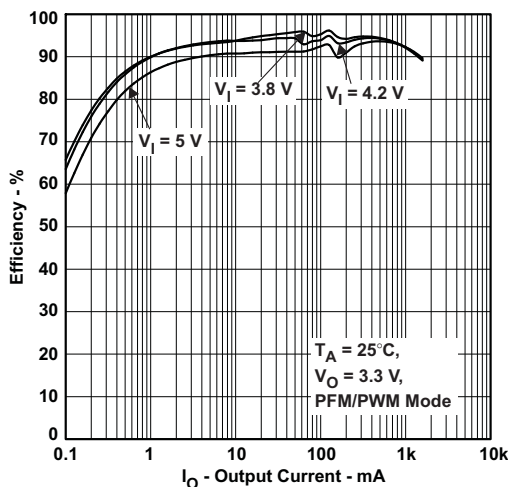

Figure 20. DCDC1: Efficiency vs Output Current

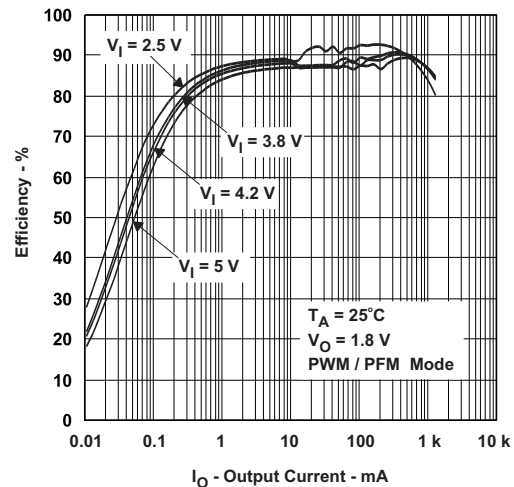

Figure 21. DCDC2: Efficiency vs Output Current

Typical Applications (continued)

10.2.2 Typical Configuration for the Titan 2 Processor

The typical configuration for the Titan processor is shown in Figure 22. This application highlights the ability to increase the voltage on DCDC3 by using a single external resistor.

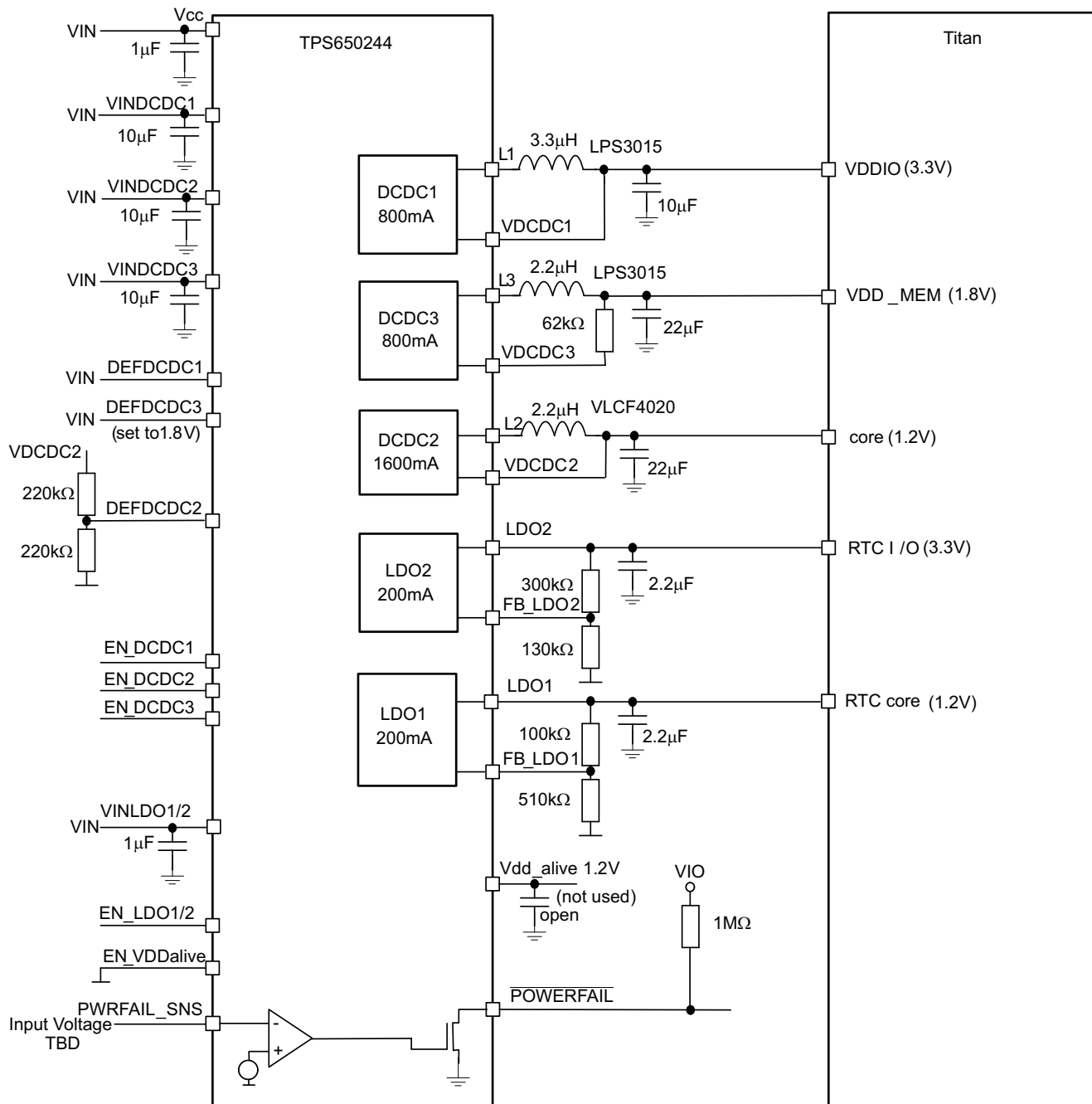

Figure 22. Titan Processor Configuration

10.2.2.1 Design Requirements

Each step-down converter requires an input decoupling capacitor, an output inductor, and an output filter capacitor. Desired output voltages must be configured through appropriate DEFDCDCx voltages, and all components must be selected to handle the maximum output currents, as well as any transient or ripple specifications that may be required for the expected loads.

Typical Applications (continued)

The LDOs must have a decoupling capacitor on the input voltage pin, and a dedicated filter capacitor on each LDO output.

10.2.2.2 Detailed Design Procedure

Refer to the Samsung Processor [Detailed Design Procedure](#) for full design procedure details.

As only DCDC2 on the TPS650244 is capable of supporting a sufficient core current up to 1.6 A, a resistive divider is first implemented on DEFDCDC2 to produce this required 1.2-V rail. DCDC3 is then modified to support the memory voltage of 1.8 V. As DCDC3 cannot support 1.8 V from a default configuration, the output voltage is first programmed to a lower value, in this case 1.6 V, by setting DEFDCDC3 = HIGH. Even though DCDC3 does not support an external resistor divider on DEFDCDC3, it can still be tricked into regulating a higher output voltage of 1.8 V by presenting the VDCDC3 feedback pin with 200 mV less than the original target of 1.6 V. The internal resistance at VDCDC3 when programmed to 1.6 V is 480 k Ω , so the external resistance needed to drop 200 mV within the feedback path and increase the output voltage from 1.6 V to 1.8 V is 60 k Ω (62 k Ω).

11 Power Supply Recommendations

To avoid damaging the device, ensure all applied voltages to the pins do not exceed the absolute maximums listed in [Absolute Maximum Ratings](#). Input voltage to the LDOs must be at least 300 mV higher than the largest LDO output voltage to accommodate for the maximum dropout voltage. As power supply requirements varies across applications, consider the expected output voltages and the maximum load currents of each regulator when determining a minimum required current rating for an acceptable power supply.

12 Layout

12.1 Layout Guidelines

- The input capacitors for the DC-DC converters must be placed as close as possible to the VINDCDCx and V_{CC} pins.
- The inductor of the output filter must be placed as close as possible to the device to provide the shortest switch node possible, reducing the noise emitted into the system and increasing the efficiency.
- Sense the feedback voltage of the output at the output capacitors to ensure the best DC accuracy. Feedback must be routed away from noisy sources such as the inductor. If possible route on the opposite side from the switch node and inductor and place a GND plane between the feedback and the noisy sources or a keep-out underneath them entirely.
- Place the output capacitors as close as possible to the inductor to reduce the feedback loop. This ensures the best regulation at the feedback point.
- Place the device as close as possible to the most demanding or sensitive load. The output capacitors must be placed close to the input of the load. This ensures the best AC performance possible.
- The input and output capacitors for the LDOs must be placed close to the device for best regulation performance.
- Use vias to connect thermal pad to ground plane.
- A common ground plane is recommended for the layout of this device. The AGND can be separated from the PGND, but a large low-parasitic PGND is required to connect the PGNDx pins to the CIN and external PGND connections. If the AGND and PGND planes are separated, have one connection point to reference the grounds together. Place this connection point close to the IC.

12.2 Layout Example

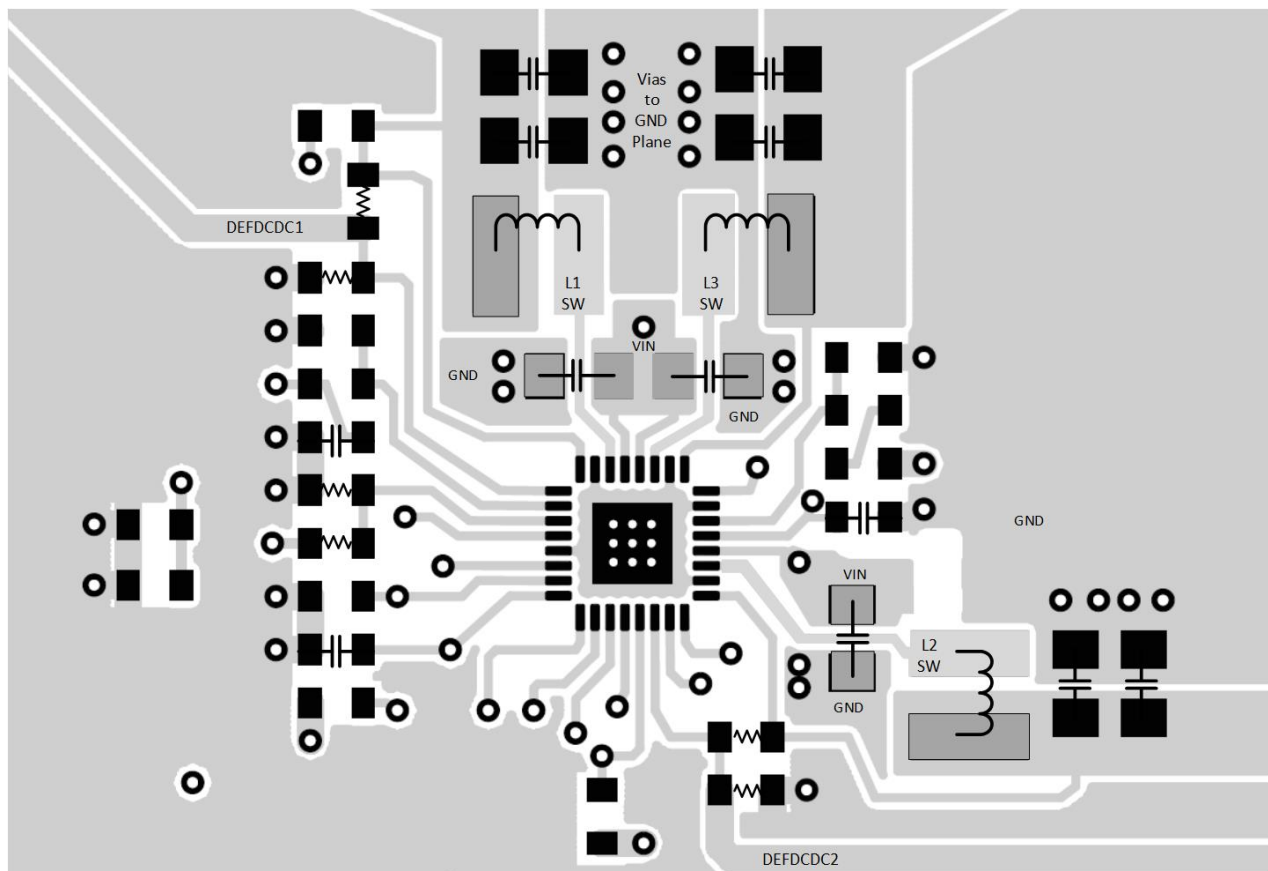

Figure 23. Layout Diagram

13 Device and Documentation Support

13.1 Related Links

The table below lists quick access links. Categories include technical documents, support and community resources, tools and software, and quick access to sample or buy.

Table 4. Related Links

PARTS	PRODUCT FOLDER	SAMPLE & BUY	TECHNICAL DOCUMENTS	TOOLS & SOFTWARE	SUPPORT & COMMUNITY
TPS650240	Click here	Click here	Click here	Click here	Click here
TPS650241	Click here	Click here	Click here	Click here	Click here
TPS650242	Click here	Click here	Click here	Click here	Click here
TPS650243	Click here	Click here	Click here	Click here	Click here
TPS650244	Click here	Click here	Click here	Click here	Click here
TPS650245	Click here	Click here	Click here	Click here	Click here

13.2 Community Resources

The following links connect to TI community resources. Linked contents are provided "AS IS" by the respective contributors. They do not constitute TI specifications and do not necessarily reflect TI's views; see TI's [Terms of Use](#).

TI E2E™ Online Community *TI's Engineer-to-Engineer (E2E) Community*. Created to foster collaboration among engineers. At e2e.ti.com, you can ask questions, share knowledge, explore ideas and help solve problems with fellow engineers.

Design Support *TI's Design Support* Quickly find helpful E2E forums along with design support tools and contact information for technical support.

13.3 Trademarks

E2E is a trademark of Texas Instruments.
All other trademarks are the property of their respective owners.

13.4 Electrostatic Discharge Caution



These devices have limited built-in ESD protection. The leads should be shorted together or the device placed in conductive foam during storage or handling to prevent electrostatic damage to the MOS gates.

13.5 Glossary

[SLYZ022](#) — *TI Glossary*.

This glossary lists and explains terms, acronyms, and definitions.

14 Mechanical, Packaging, and Orderable Information

The following pages include mechanical, packaging, and orderable information. This information is the most current data available for the designated devices. This data is subject to change without notice and revision of this document. For browser-based versions of this data sheet, refer to the left-hand navigation.

PACKAGING INFORMATION

Orderable Device	Status (1)	Package Type	Package Drawing	Pins	Package Qty	Eco Plan (2)	Lead/Ball Finish (6)	MSL Peak Temp (3)	Op Temp (°C)	Device Marking (4/5)	Samples
TPS650240RHBR	ACTIVE	VQFN	RHB	32	3000	Green (RoHS & no Sb/Br)	CU NIPDAU	Level-2-260C-1 YEAR	-40 to 85	TPS 650240	Samples
TPS650240RHBT	ACTIVE	VQFN	RHB	32	250	Green (RoHS & no Sb/Br)	CU NIPDAU	Level-2-260C-1 YEAR	-40 to 85	TPS 650240	Samples
TPS650241RHBR	ACTIVE	VQFN	RHB	32	3000	Green (RoHS & no Sb/Br)	CU NIPDAU	Level-2-260C-1 YEAR	-40 to 85	TPS 650241	Samples
TPS650241RHBRG4	ACTIVE	VQFN	RHB	32	3000	Green (RoHS & no Sb/Br)	CU NIPDAU	Level-2-260C-1 YEAR	-40 to 85	TPS 650241	Samples
TPS650241RHBT	ACTIVE	VQFN	RHB	32	250	Green (RoHS & no Sb/Br)	CU NIPDAU	Level-2-260C-1 YEAR	-40 to 85	TPS 650241	Samples
TPS650242RHBT	ACTIVE	VQFN	RHB	32	250	Green (RoHS & no Sb/Br)	CU NIPDAU	Level-2-260C-1 YEAR	-40 to 85	TPS 650242	Samples
TPS650242RHBTG4	ACTIVE	VQFN	RHB	32	250	Green (RoHS & no Sb/Br)	CU NIPDAU	Level-2-260C-1 YEAR	-40 to 85	TPS 650242	Samples
TPS650243RHBR	ACTIVE	VQFN	RHB	32	3000	Green (RoHS & no Sb/Br)	CU NIPDAU	Level-2-260C-1 YEAR	-40 to 85	TPS 650243	Samples
TPS650243RHBT	ACTIVE	VQFN	RHB	32	250	Green (RoHS & no Sb/Br)	CU NIPDAU	Level-2-260C-1 YEAR	-40 to 85	TPS 650243	Samples
TPS650244RHBR	ACTIVE	VQFN	RHB	32	3000	Green (RoHS & no Sb/Br)	CU NIPDAU	Level-2-260C-1 YEAR	-40 to 85	TPS 650244	Samples
TPS650244RHBT	ACTIVE	VQFN	RHB	32	250	Green (RoHS & no Sb/Br)	CU NIPDAU	Level-2-260C-1 YEAR	-40 to 85	TPS 650244	Samples
TPS650245RHBR	ACTIVE	VQFN	RHB	32	3000	Green (RoHS & no Sb/Br)	CU NIPDAU	Level-2-260C-1 YEAR	-40 to 85	TPS 650245	Samples
TPS650245RHBT	ACTIVE	VQFN	RHB	32	250	Green (RoHS & no Sb/Br)	CU NIPDAU	Level-2-260C-1 YEAR	-40 to 85	TPS 650245	Samples

(1) The marketing status values are defined as follows:

ACTIVE: Product device recommended for new designs.

LIFEBUY: TI has announced that the device will be discontinued, and a lifetime-buy period is in effect.

NRND: Not recommended for new designs. Device is in production to support existing customers, but TI does not recommend using this part in a new design.

PREVIEW: Device has been announced but is not in production. Samples may or may not be available.

OBSOLETE: TI has discontinued the production of the device.

(2) **RoHS:** TI defines "RoHS" to mean semiconductor products that are compliant with the current EU RoHS requirements for all 10 RoHS substances, including the requirement that RoHS substance do not exceed 0.1% by weight in homogeneous materials. Where designed to be soldered at high temperatures, "RoHS" products are suitable for use in specified lead-free processes. TI may reference these types of products as "Pb-Free".

RoHS Exempt: TI defines "RoHS Exempt" to mean products that contain lead but are compliant with EU RoHS pursuant to a specific EU RoHS exemption.

Green: TI defines "Green" to mean the content of Chlorine (Cl) and Bromine (Br) based flame retardants meet JS709B low halogen requirements of ≤ 1000 ppm threshold. Antimony trioxide based flame retardants must also meet the ≤ 1000 ppm threshold requirement.

(3) MSL, Peak Temp. - The Moisture Sensitivity Level rating according to the JEDEC industry standard classifications, and peak solder temperature.

(4) There may be additional marking, which relates to the logo, the lot trace code information, or the environmental category on the device.

(5) Multiple Device Markings will be inside parentheses. Only one Device Marking contained in parentheses and separated by a "~" will appear on a device. If a line is indented then it is a continuation of the previous line and the two combined represent the entire Device Marking for that device.

(6) Lead/Ball Finish - Orderable Devices may have multiple material finish options. Finish options are separated by a vertical ruled line. Lead/Ball Finish values may wrap to two lines if the finish value exceeds the maximum column width.

Important Information and Disclaimer: The information provided on this page represents TI's knowledge and belief as of the date that it is provided. TI bases its knowledge and belief on information provided by third parties, and makes no representation or warranty as to the accuracy of such information. Efforts are underway to better integrate information from third parties. TI has taken and continues to take reasonable steps to provide representative and accurate information but may not have conducted destructive testing or chemical analysis on incoming materials and chemicals. TI and TI suppliers consider certain information to be proprietary, and thus CAS numbers and other limited information may not be available for release.

In no event shall TI's liability arising out of such information exceed the total purchase price of the TI part(s) at issue in this document sold by TI to Customer on an annual basis.

OTHER QUALIFIED VERSIONS OF TPS650241, TPS650243, TPS650244 :

- Automotive: [TPS650241-Q1](#), [TPS650243-Q1](#), [TPS650244-Q1](#)

NOTE: Qualified Version Definitions:

- Automotive - Q100 devices qualified for high-reliability automotive applications targeting zero defects

TAPE AND REEL INFORMATION

QUADRANT ASSIGNMENTS FOR PIN 1 ORIENTATION IN TAPE

*All dimensions are nominal

Device	Package Type	Package Drawing	Pins	SPQ	Reel Diameter (mm)	Reel Width W1 (mm)	A0 (mm)	B0 (mm)	K0 (mm)	P1 (mm)	W (mm)	Pin1 Quadrant
TPS650240RHBR	VQFN	RHB	32	3000	330.0	12.4	5.3	5.3	1.1	8.0	12.0	Q2
TPS650240RHBR	VQFN	RHB	32	3000	330.0	12.4	5.3	5.3	1.5	8.0	12.0	Q2
TPS650240RHBT	VQFN	RHB	32	250	180.0	12.4	5.3	5.3	1.5	8.0	12.0	Q2
TPS650240RHBT	VQFN	RHB	32	250	180.0	12.4	5.3	5.3	1.1	8.0	12.0	Q2
TPS650241RHBR	VQFN	RHB	32	3000	330.0	12.4	5.3	5.3	1.5	8.0	12.0	Q2
TPS650241RHBT	VQFN	RHB	32	250	180.0	12.4	5.3	5.3	1.5	8.0	12.0	Q2
TPS650242RHBT	VQFN	RHB	32	250	180.0	12.4	5.3	5.3	1.5	8.0	12.0	Q2
TPS650243RHBR	VQFN	RHB	32	3000	330.0	12.4	5.25	5.25	1.1	8.0	12.0	Q2
TPS650243RHBT	VQFN	RHB	32	250	180.0	12.5	5.25	5.25	1.1	8.0	12.0	Q2
TPS650244RHBR	VQFN	RHB	32	3000	330.0	12.4	5.3	5.3	1.5	8.0	12.0	Q2
TPS650244RHBT	VQFN	RHB	32	250	180.0	12.4	5.3	5.3	1.5	8.0	12.0	Q2
TPS650245RHBR	VQFN	RHB	32	3000	330.0	12.4	5.3	5.3	1.5	8.0	12.0	Q2
TPS650245RHBT	VQFN	RHB	32	250	180.0	12.4	5.3	5.3	1.5	8.0	12.0	Q2

TAPE AND REEL BOX DIMENSIONS

*All dimensions are nominal

Device	Package Type	Package Drawing	Pins	SPQ	Length (mm)	Width (mm)	Height (mm)
TPS650240RHBR	VQFN	RHB	32	3000	367.0	367.0	35.0
TPS650240RHBR	VQFN	RHB	32	3000	367.0	367.0	35.0
TPS650240RHBT	VQFN	RHB	32	250	210.0	185.0	35.0
TPS650240RHBT	VQFN	RHB	32	250	210.0	185.0	35.0
TPS650241RHBR	VQFN	RHB	32	3000	367.0	367.0	35.0
TPS650241RHBT	VQFN	RHB	32	250	210.0	185.0	35.0
TPS650242RHBT	VQFN	RHB	32	250	210.0	185.0	35.0
TPS650243RHBR	VQFN	RHB	32	3000	338.0	355.0	50.0
TPS650243RHBT	VQFN	RHB	32	250	338.0	355.0	50.0
TPS650244RHBR	VQFN	RHB	32	3000	367.0	367.0	35.0
TPS650244RHBT	VQFN	RHB	32	250	210.0	185.0	35.0
TPS650245RHBR	VQFN	RHB	32	3000	367.0	367.0	35.0
TPS650245RHBT	VQFN	RHB	32	250	210.0	185.0	35.0

GENERIC PACKAGE VIEW

RHB 32

VQFN - 1 mm max height

5 x 5, 0.5 mm pitch

PLASTIC QUAD FLATPACK - NO LEAD

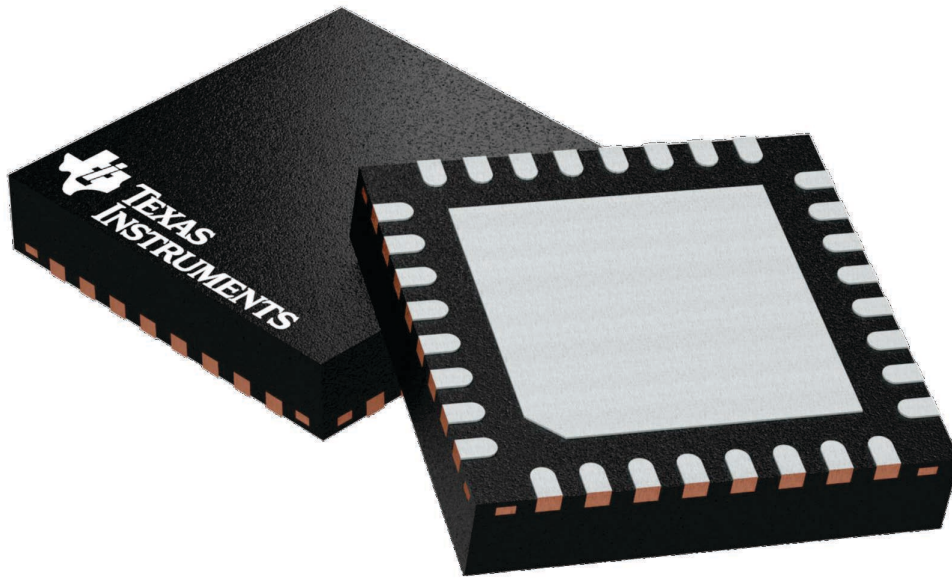

Images above are just a representation of the package family, actual package may vary.
Refer to the product data sheet for package details.

4224745/A

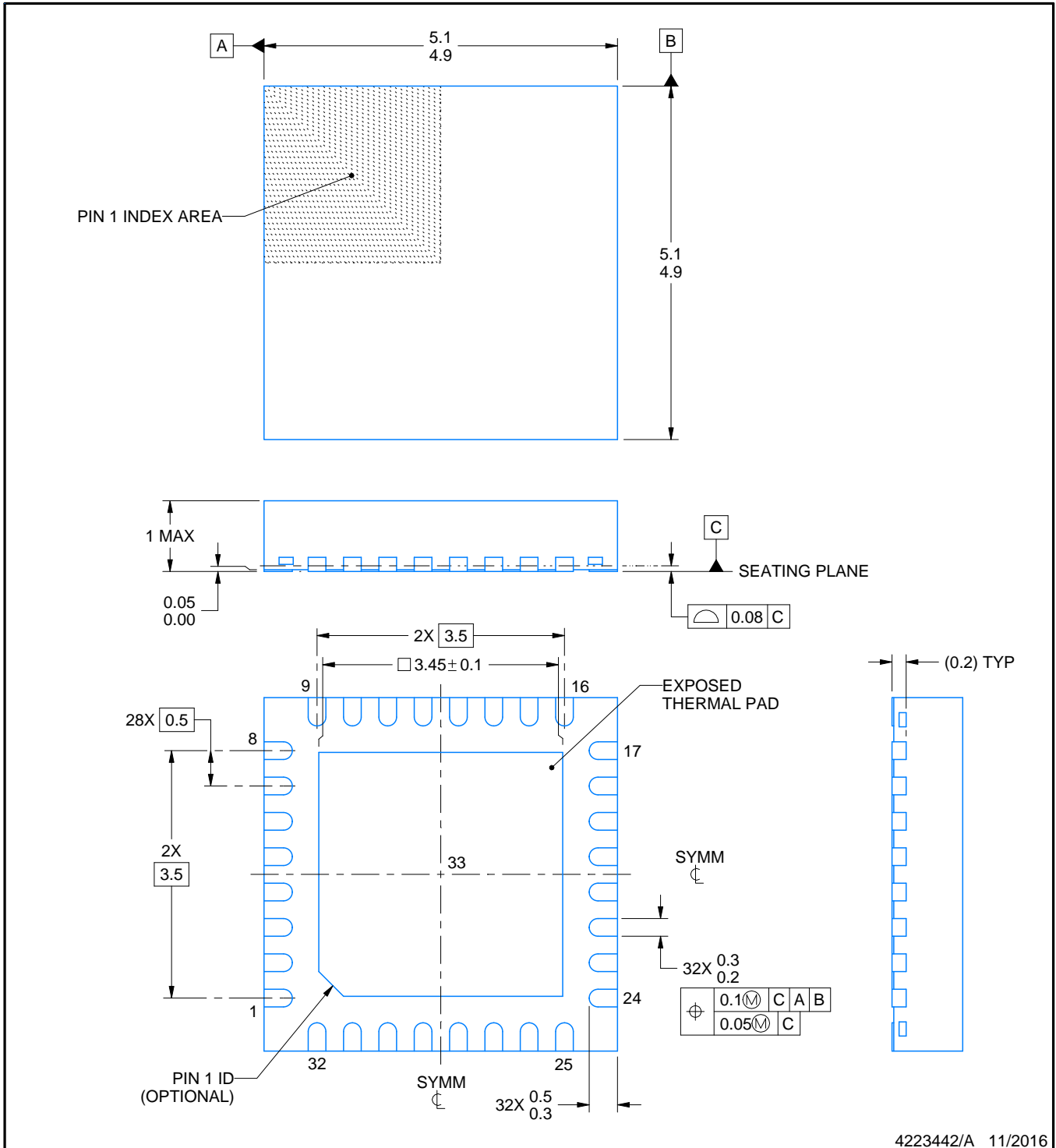
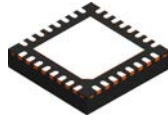

4223442/A 11/2016

NOTES:

1. All linear dimensions are in millimeters. Any dimensions in parenthesis are for reference only. Dimensioning and tolerancing per ASME Y14.5M.
2. This drawing is subject to change without notice.
3. The package thermal pad must be soldered to the printed circuit board for thermal and mechanical performance.

EXAMPLE BOARD LAYOUT

RHB0032E

VQFN - 1 mm max height

PLASTIC QUAD FLATPACK - NO LEAD

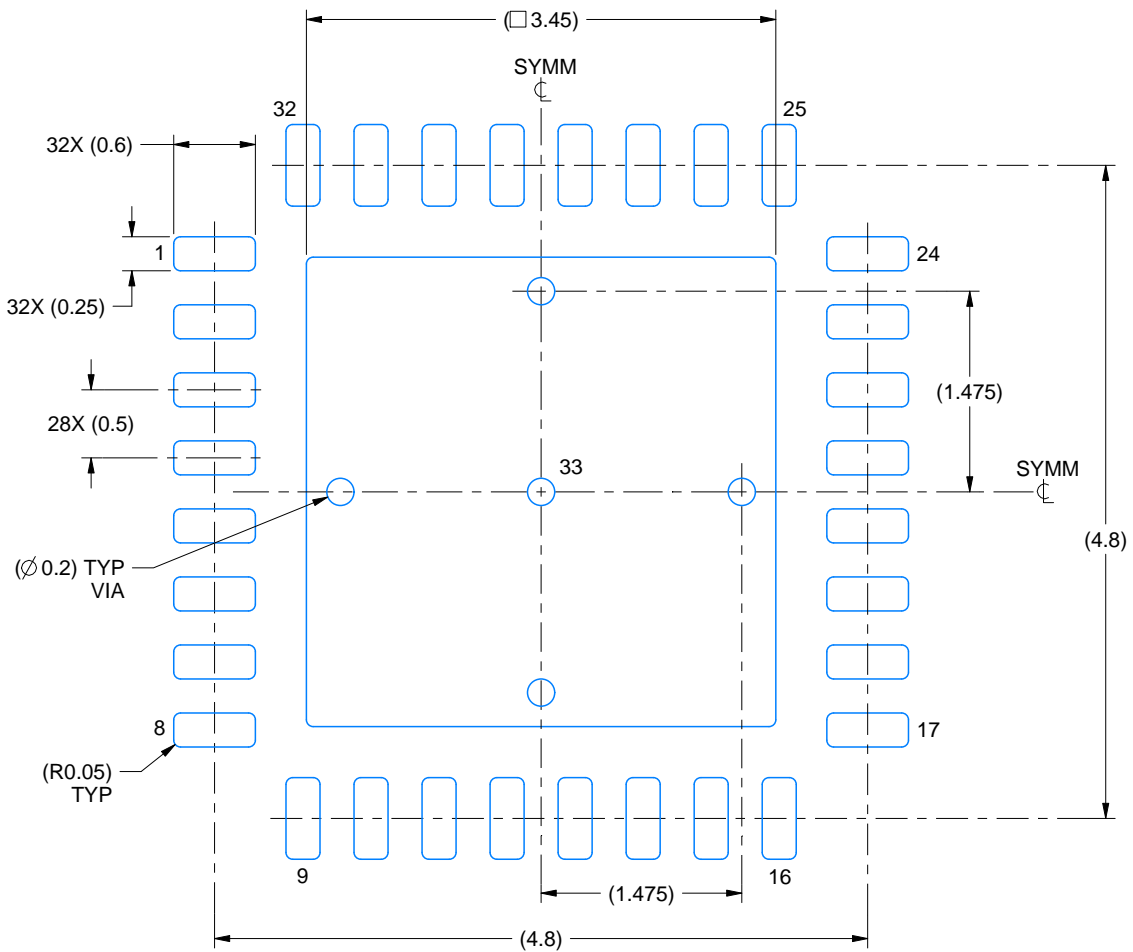

LAND PATTERN EXAMPLE
SCALE:18X

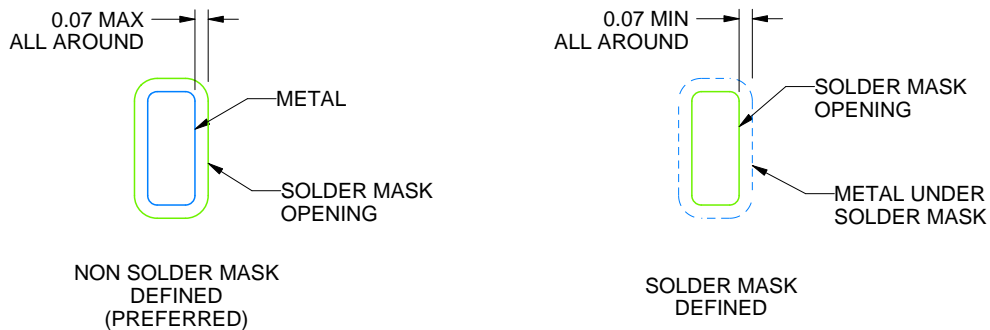

SOLDER MASK DETAILS

4223442/A 11/2016

NOTES: (continued)

- This package is designed to be soldered to a thermal pad on the board. For more information, see Texas Instruments literature number SLUA271 (www.ti.com/lit/slua271).
- Vias are optional depending on application, refer to device data sheet. If any vias are implemented, refer to their locations shown on this view. It is recommended that vias under paste be filled, plugged or tented.

EXAMPLE STENCIL DESIGN

RHB0032E

VQFN - 1 mm max height

PLASTIC QUAD FLATPACK - NO LEAD

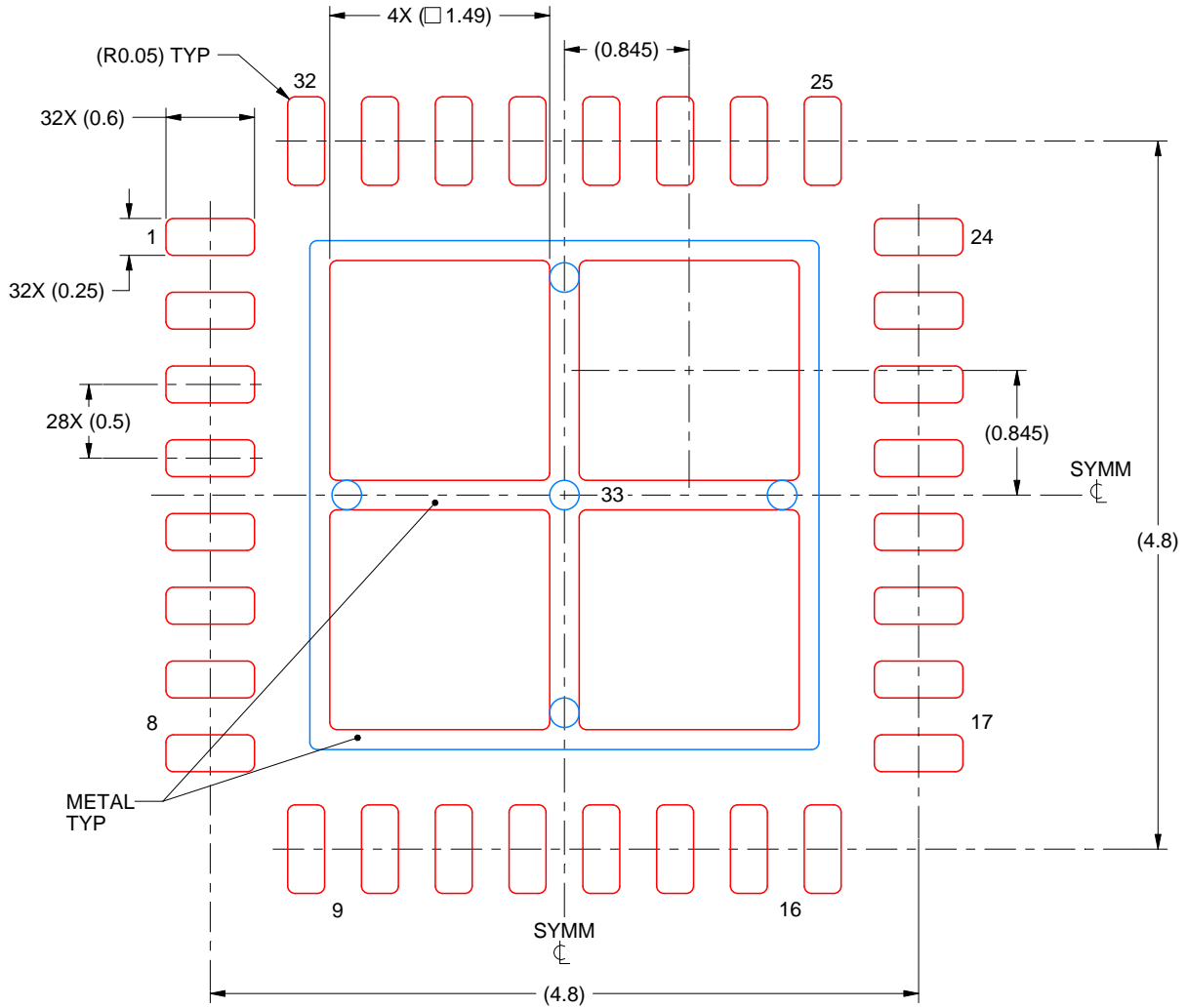

SOLDER PASTE EXAMPLE
 BASED ON 0.125 mm THICK STENCIL

EXPOSED PAD 33:
 75% PRINTED SOLDER COVERAGE BY AREA UNDER PACKAGE
 SCALE:20X

4223442/A 11/2016

NOTES: (continued)

6. Laser cutting apertures with trapezoidal walls and rounded corners may offer better paste release. IPC-7525 may have alternate design recommendations.

IMPORTANT NOTICE AND DISCLAIMER

TI PROVIDES TECHNICAL AND RELIABILITY DATA (INCLUDING DATASHEETS), DESIGN RESOURCES (INCLUDING REFERENCE DESIGNS), APPLICATION OR OTHER DESIGN ADVICE, WEB TOOLS, SAFETY INFORMATION, AND OTHER RESOURCES "AS IS" AND WITH ALL FAULTS, AND DISCLAIMS ALL WARRANTIES, EXPRESS AND IMPLIED, INCLUDING WITHOUT LIMITATION ANY IMPLIED WARRANTIES OF MERCHANTABILITY, FITNESS FOR A PARTICULAR PURPOSE OR NON-INFRINGEMENT OF THIRD PARTY INTELLECTUAL PROPERTY RIGHTS.

These resources are intended for skilled developers designing with TI products. You are solely responsible for (1) selecting the appropriate TI products for your application, (2) designing, validating and testing your application, and (3) ensuring your application meets applicable standards, and any other safety, security, or other requirements. These resources are subject to change without notice. TI grants you permission to use these resources only for development of an application that uses the TI products described in the resource. Other reproduction and display of these resources is prohibited. No license is granted to any other TI intellectual property right or to any third party intellectual property right. TI disclaims responsibility for, and you will fully indemnify TI and its representatives against, any claims, damages, costs, losses, and liabilities arising out of your use of these resources.

TI's products are provided subject to TI's Terms of Sale (www.ti.com/legal/termsofsale.html) or other applicable terms available either on ti.com or provided in conjunction with such TI products. TI's provision of these resources does not expand or otherwise alter TI's applicable warranties or warranty disclaimers for TI products.

Mailing Address: Texas Instruments, Post Office Box 655303, Dallas, Texas 75265
Copyright © 2019, Texas Instruments Incorporated

Looking for pricing, stock, or lifecycle information?

Click below to explore more details on WIN SOURCE:

 [View TPS650245RHBR](#) on WIN SOURCE

 [Texas Instruments](#) Information

Optimize Your Supply Chain with WIN SOURCE Solutions

-  Global Sourcing Solution
-  Obsolete Management
-  Cost Control Management
-  Shortage Management
-  Alternative Solution
-  Excess Inventory Management