

1.5A STEP DOWN SWITCHING REGULATOR

- UP TO 1.5A STEP DOWN CONVERTER
- OPERATING INPUT VOLTAGE FROM 6.5V TO 28V
- PRECISE 1.26V ($\pm 1\%$) INTERNAL REFERENCE VOLTAGE
- OUTPUT VOLTAGE ADJUSTABLE FROM 1.26V TO 20V
- SWITCHING FREQUENCY ADJUSTABLE UP TO 300KHz
- VOLTAGE FEEDFORWARD
- ZERO LOAD CURRENT OPERATION
- INTERNAL CURRENT LIMITING (PULSE-BY-PULSE AND HICCUP MODE)
- INHIBIT FOR ZERO CURRENT CONSUMPTION
- PROTECTION AGAINST FEEDBACK DISCONNECTION
- THERMAL SHUTDOWN
- SOFT START FUNCTION

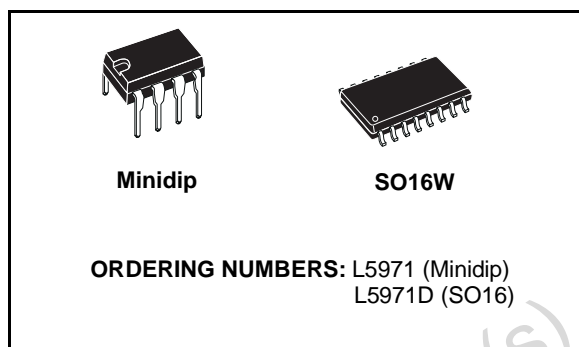

A switching frequency up to 300KHz is achievable (the maximum power dissipation of the packages must be observed).

Features of this new generation of DC-DC converter include pulse-by-pulse current limit, hiccup mode for short circuit protection, voltage feedforward regulation, soft-start, protection against feedback loop disconnection, inhibit for zero current consumption and thermal shutdown.

The device is available in plastic dual in line, MINI-DIP 8 for standard assembly, and SO16 for SMD assembly.

Typical Applications:

- High efficiency step-down converter
- Portable computers
- Battery charger
- Distributed power
- PDAs and Mobile Communicators

DESCRIPTION

The L5971 is a step down monolithic power switching regulator delivering 1.5A at a voltage between 1.26V and 20V (selected by a simple external divider). Realized in BCD mixed technology, the device uses an internal power D-MOS transistor (with a typical $R_{ds(on)}$ of 0.25Ω) to obtain very high efficiency and high switching speed.

TYPICAL APPLICATION CIRCUIT

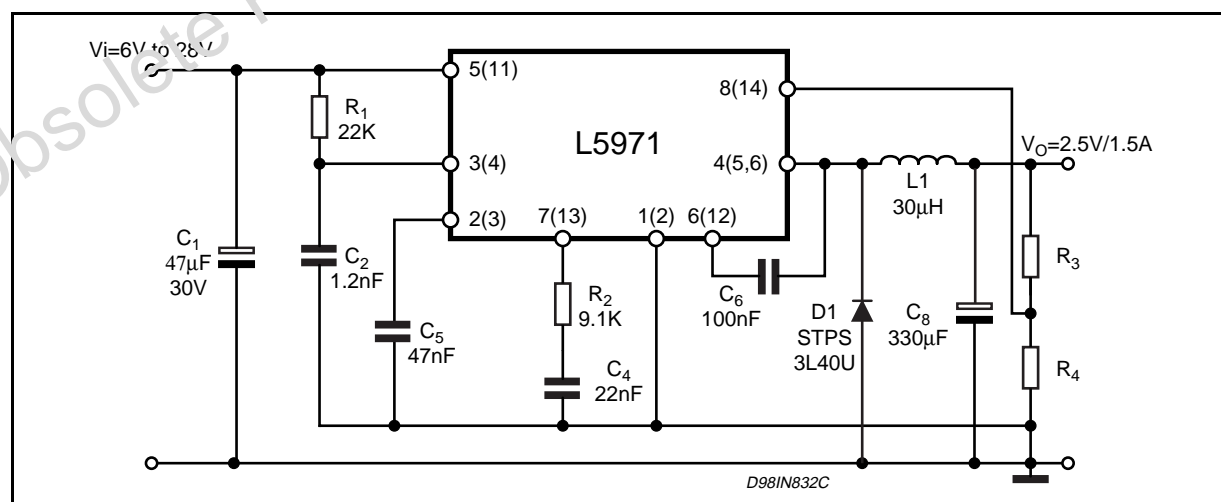

BLOCK DIAGRAM

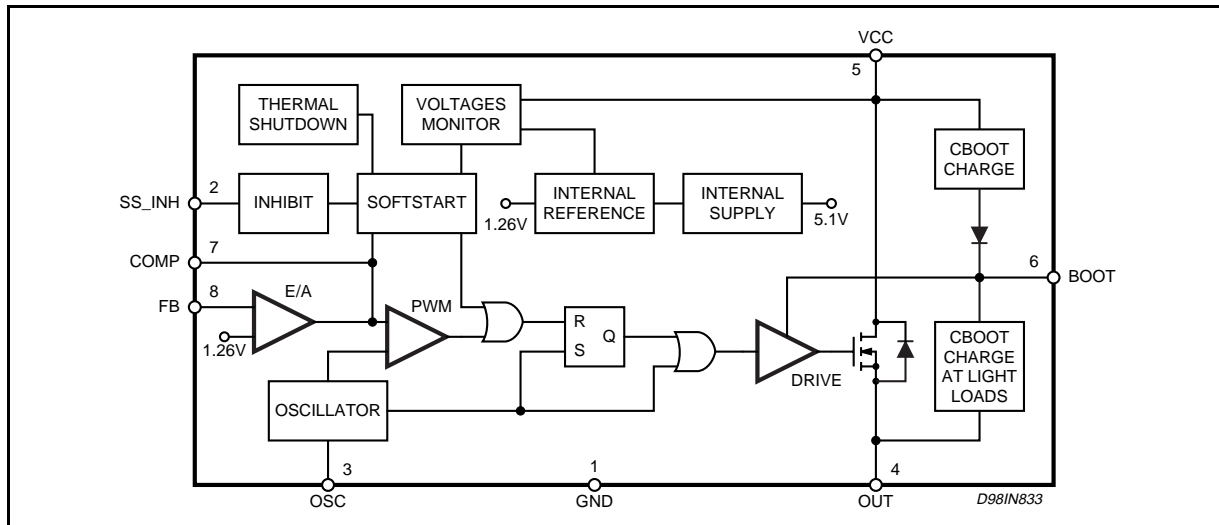

PIN CONNECTIONS

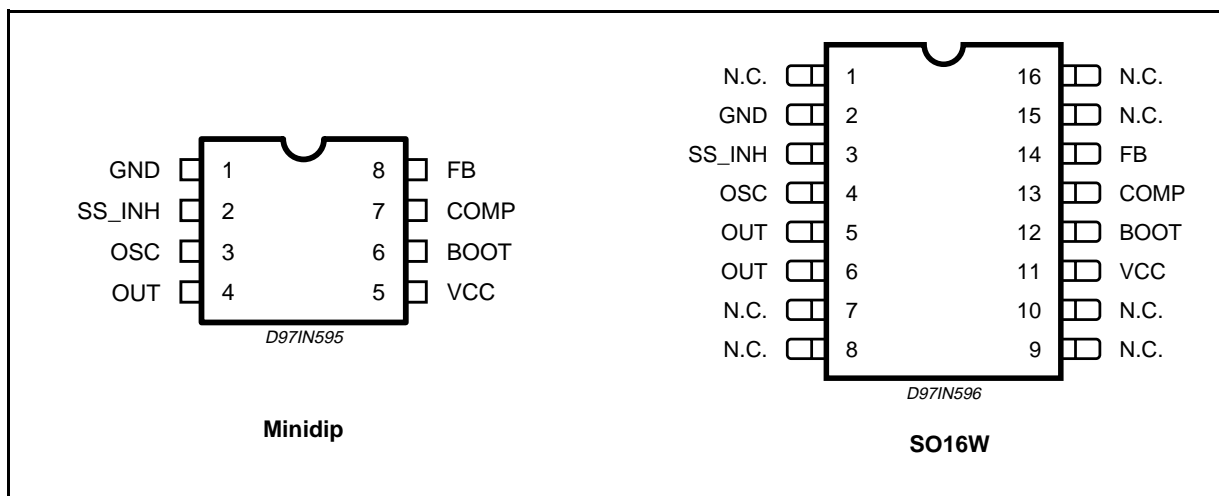

PIN FUNCTIONS

DIP	SO (*)	Name	Function
1	2	GND	Ground
2	3	SS_INH	A logic signal (active low) disables the device (sleep mode operation). A capacitor connected between this pin and ground determines the soft start time. When this pin is grounded disables the device (driven by open collector/drain).
3	4	OSC	An external resistor connected between the unregulated input voltage and this pin and a capacitor connected from this pin to ground fix the switching frequency. (Line feed forward is automatically obtained)
4	5, 6	OUT	Stepdown regulator output
5	11	V _{CC}	Not regulated DC input voltage
6	12	BOOT	A capacitor connected between this pin and OUT allows to drive the internal VDMOS
7	13	COMP	E/A output to be used for frequency compensation
8	14	FB	Stepdown feedback input. Connecting directly this pin to the output 1.26V is obtained; a voltage divider is requested for higher output voltages

(*) Pins 1, 7, 8, 9, 10, 15 and 16 are not internally, electrically connected to the die.

THERMAL DATA

Symbol	Parameter	Max.	Minidip	SO16	Unit
$R_{th(j-amb)}$	Thermal Resistance Junction to ambient		90 (*)	110 (*)	°C/W

(*) Package mounted on board.

ABSOLUTE MAXIMUM RATINGS

Symbol		Parameter	Value	Unit	
Minidip	SO16				
V_5, V_3	V_{11}, V_4	Input voltage	30	V	
V_4	V_5, V_6	Output DC voltage	-1	V	
		Output peak voltage at $t = 0.1\mu s$ $f = 200KHz$	-5	V	
I_4	I_5, I_6	Maximum output current	int. limit.		
$V_6 - V_5$	$V_{12} - V_{11}$		14	V	
V_6	V_{12}	Bootstrap voltage	45	V	
V_7, V_2	V_{13}, V_3	Analogs input voltage ($V_{CC} = 12V$)	10	V	
V_8	V_{14}	($V_{CC} = 20V$)	6 -0.3	V V	
P_{tot}		Power dissipation a $T_{amb} \leq 60^\circ C$	Minidip	1	W
			SO16	0.8	W
T_j, T_{stg}		Junction and storage temperature	-40 to 150	°C	

ELECTRICAL CHARACTERISTICS ($T_j = 25^\circ C$, $C_{osc} = 2.7nF$, $R_{osc} = 20k\Omega$, $V_{CC} = 12V$, unless otherwise specified.) * Specification Referred to T_j from 0 to $125^\circ C$

Symbol	Parameter	Test Condition	Min.	Typ.	Max.	Unit	
DYNAMIC CHARACTERISTIC							
V_i	Operating input voltage range		*	6.5	28	V	
V_o	Output voltage	$I_o = 0.5A$		1.247	1.26	1.273	V
		$I_o = 0.2$ to $1.5A$		1.235	1.26	1.285	V
		$V_{CC} = 6.5$ to $25V$	*	1.21	1.26	1.31	V
V_d	Dropout voltage	$V_{CC} = 10V$; $I_o = 1.5A$			0.44	0.55	V
			*			0.88	V
I_l	Maximum limiting current	$V_{CC} = 6.5$ to $25V$	*	2	2.5	3	A
	Efficiency	$V_o = 3.3V$; $I_o = 1.5A$			85		%
f_s	Switching frequency		*	90	100	110	KHz
SVRR	Supply voltage ripple rejection	$V_i = V_{CC} + 2V_{RMS}$; $V_o = V_{ref}$; $I_o = 1.5A$; $f_{ripple} = 100Hz$		60			dB
	Voltage stability of switching frequency	$V_{CC} = 6.5$ to $25V$			3	6	%
	Temp. stability of switching frequency	$T_j = 0$ to $125^\circ C$			4		%
Soft Start							
	Soft start charge current			30	40	50	μA
	Soft start discharge current			6	10	14	μA
Inhibit							
V_{LL}	Low level voltage		*			0.9	V
I_{sLL}	Isorce Low level		*		5	15	μA

ELECTRICAL CHARACTERISTICS (continued)

Symbol	Parameter	Test Condition	Min.	Typ.	Max.	Unit
DC Characteristics						
I_{qop}	Total operating quiescent current	Pin 5 (Pin 11)		3	4.5	mA
I_q	Quiescent current	Duty Cycle = 0; $V_{FB} = 1.7V$		2.8	3.5	mA
I_{qst-by}	Total stand-by quiescent current	$V_{inh} < 0.9V$		100	200	μA
		$V_{CC} = 25V$; $V_{inh} < 0.9V$		150	300	μA
Error Amplifier						
V_{FB}	Voltage Feedback Input		1.247	1.26	1.273	V
R_L	Line regulation	$V_{CC} = 6.5$ to $25V$		5	10	mV
	Ref. voltage stability vs temperature		*	0.4		mV/ $^{\circ}C$
V_{oH}	High level output voltage	$V_{FB} = 0.8V$	8.7			V
V_{oL}	Low level output voltage	$V_{FB} = 1.7V$			0.65	V
$I_{o source}$	Source output current	$V_{comp} = 3V$; $V_{FB} = 0.8V$	180	250		μA
$I_{o sink}$	Sink output current	$V_{comp} = 3V$; $V_{FB} = 1.7V$	200	300		μA
I_b	Source bias current			2	3	μA
SVRR E/A	Supply voltage ripple rejection	$V_{comp} = V_{fb}$; $V_{CC} = 6.5$ to $25V$	60	80		dB
	DC open loop gain	$R_L = \infty$	50	57		dB
g_m	Transconductance	$I_{comp} = -0.1$ to $0.1mA$ $V_{comp} = 6V$		4.3		mS
Oscillator Section						
	Ramp Valley		0.74	0.81	0.88	V
	Ramp peak	$V_{CC} = 6.5V$	1.80	1.87	1.94	V
		$V_{CC} = 25V$	4.72	4.79	4.86	V
	Maximum duty cycle		95	97		%
	Maximum Frequency	Duty Cycle = 0% $R_{osc} = 13k\Omega$, $C_{osc} = 820pF$			300	kHz

Figure 1. Test and valuation board circuit.

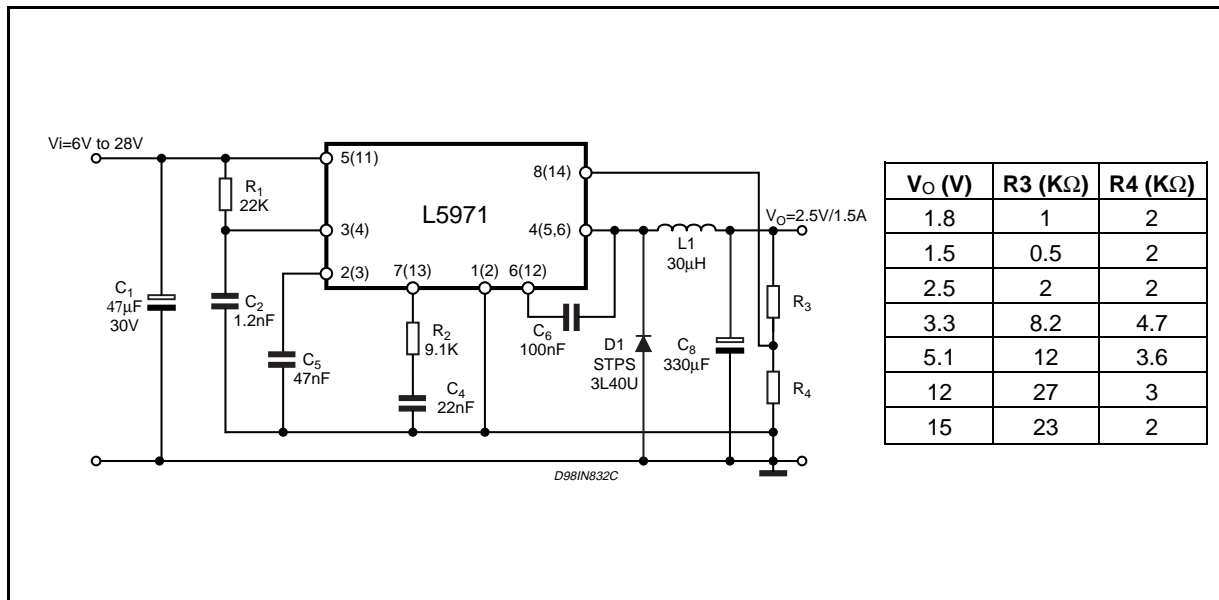

Figure 2. PCB and component layout of the figure 1.

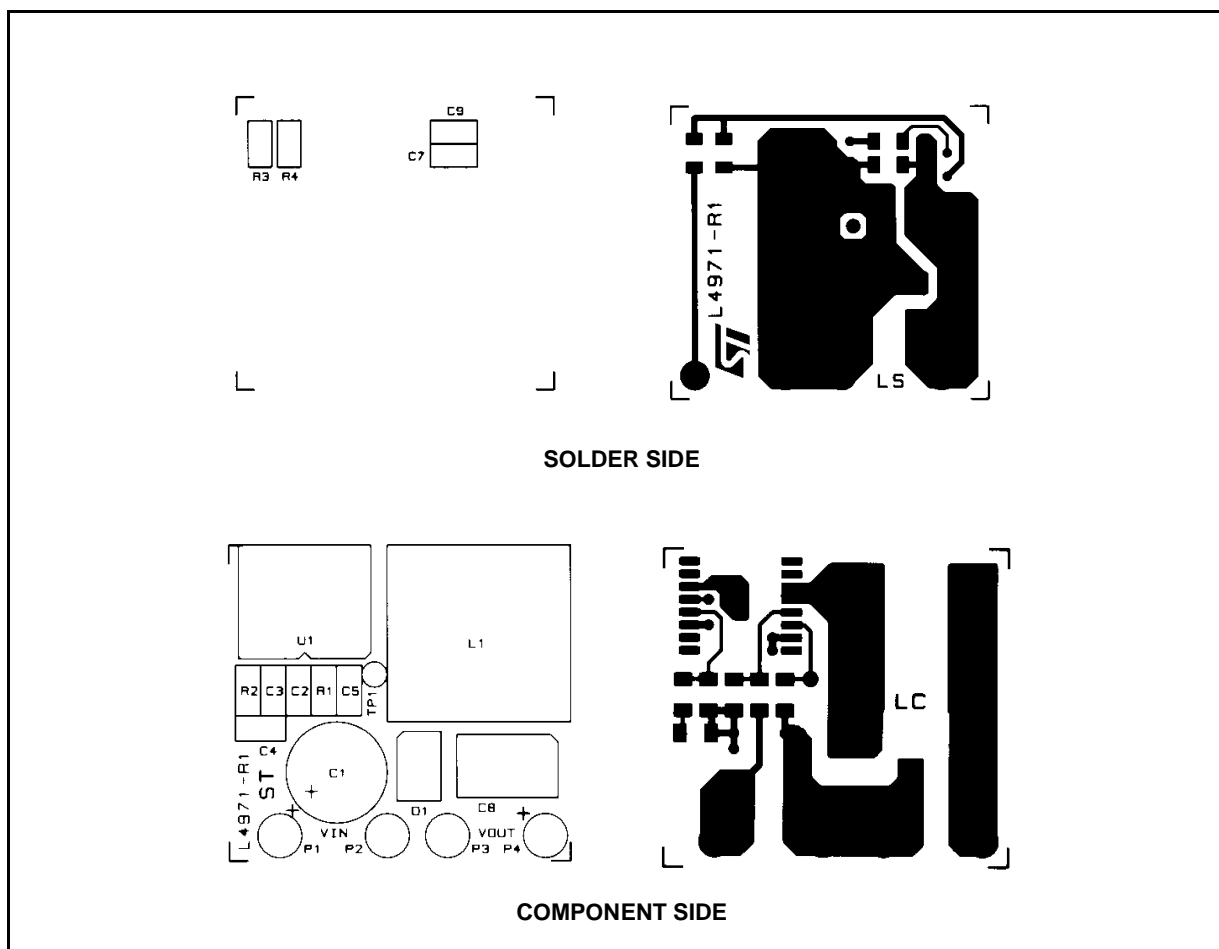

Figure 3. Quiescent drain current vs. input voltage.

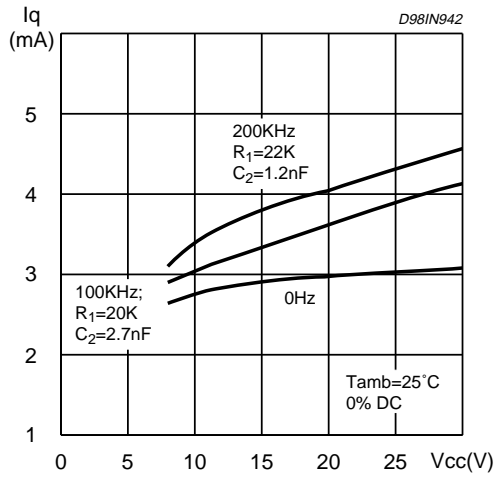

Figure 4. Quiescent current vs. junction temperature

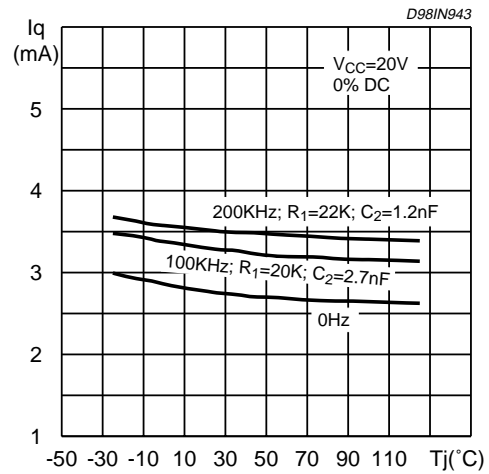

Figure 5. Stand-by drain current vs. input voltage

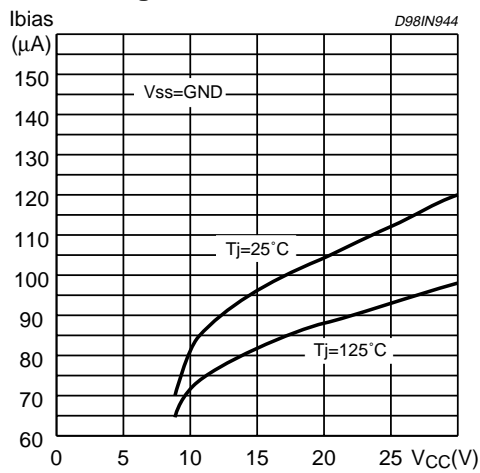

Figure 6. Line Regulation

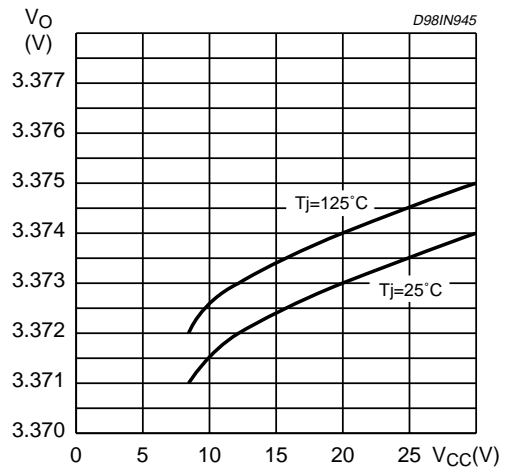

Figure 7. Switching frequency vs. R1 and C2

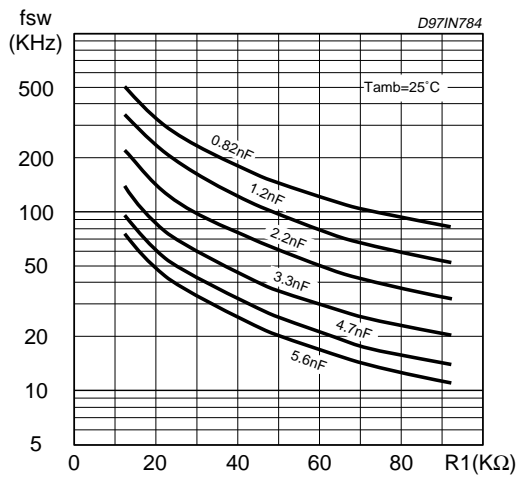

Figure 8. Switching Frequency vs. input voltage.

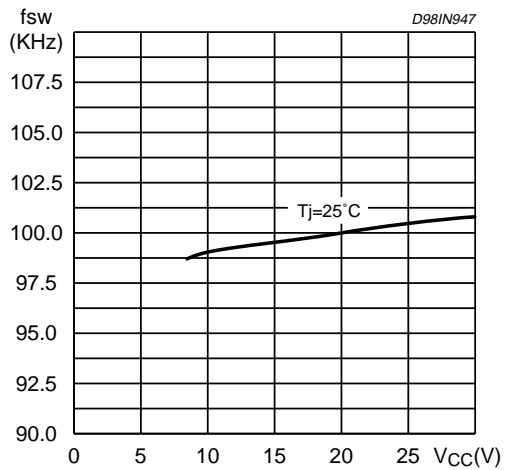

Figure 9. Switching frequency vs. junction temperature.

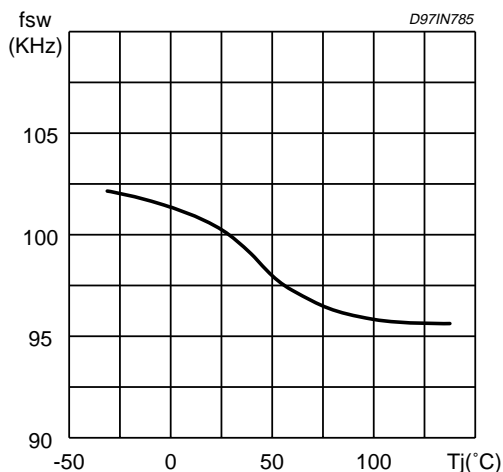

Figure 10. Dropout voltage between pin 5 and 4.

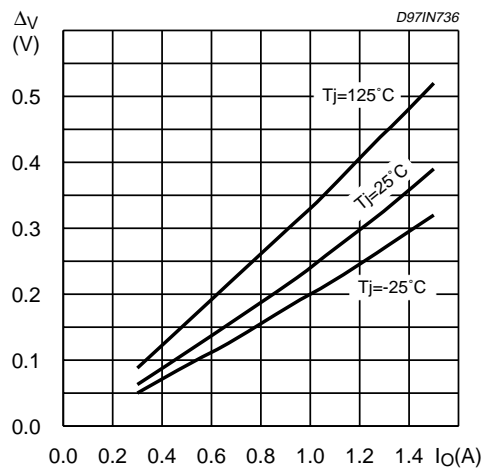

Figure 11. Efficiency vs output voltage.

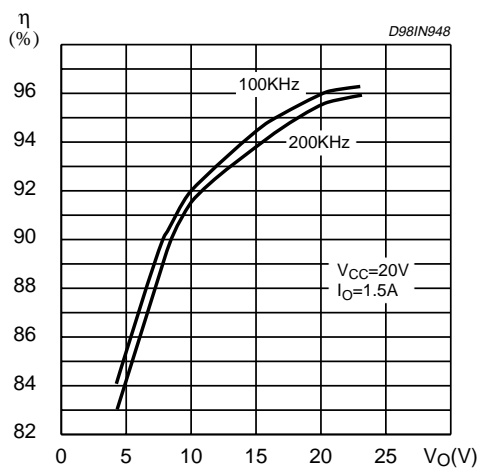

Figure 12. Efficiency vs. output current.

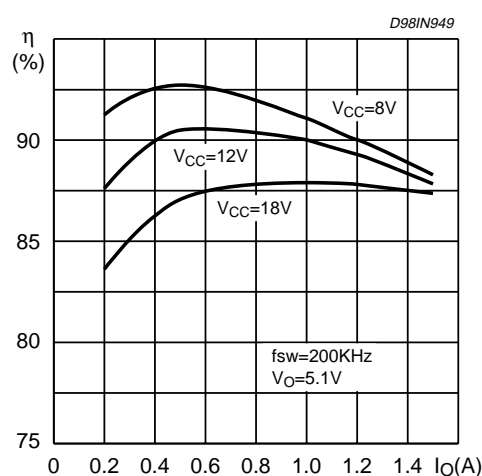

Figure 13. Efficiency vs output current.

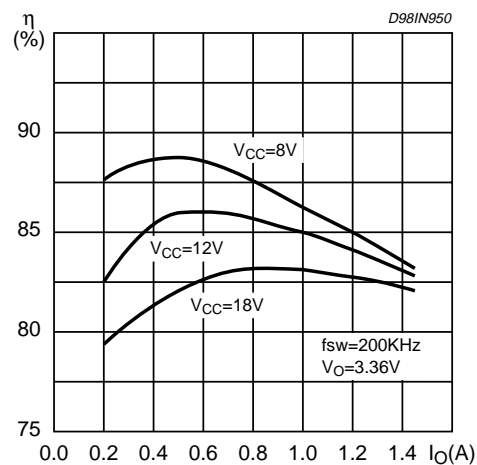

Figure 14. Efficiency vs. output current.

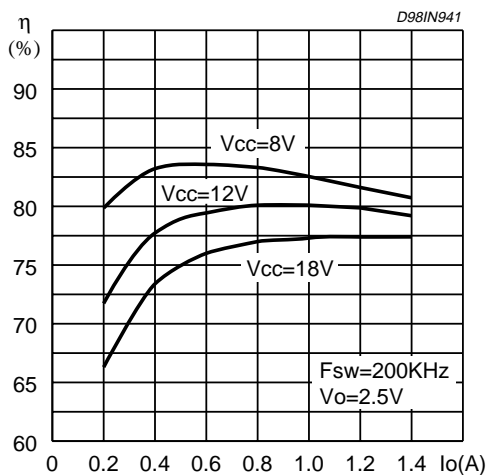

Figure 15. Load transient.

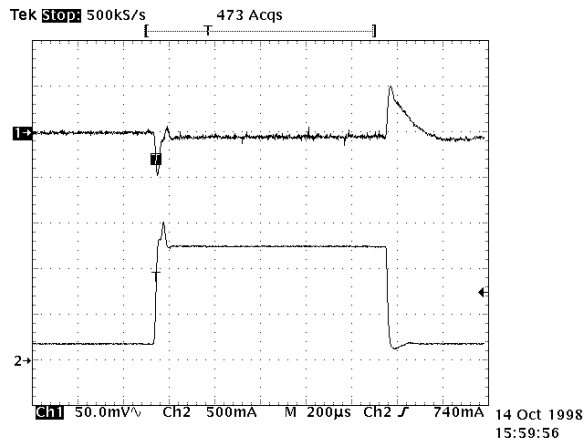

Figure 16. Soft start capacitor selection vs. Inductor and V_{CCmax}

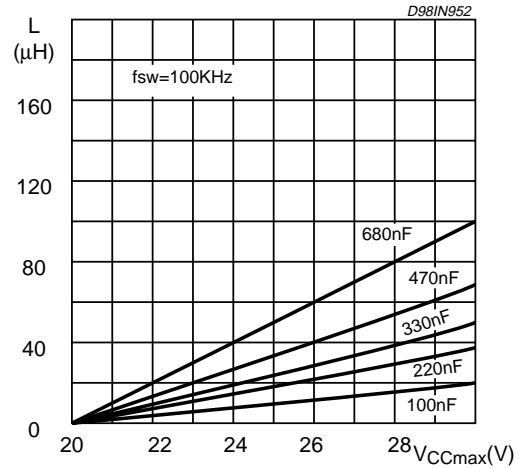

Figure 17. Soft start capacitor selection vs. Inductor and V_{CCmax}

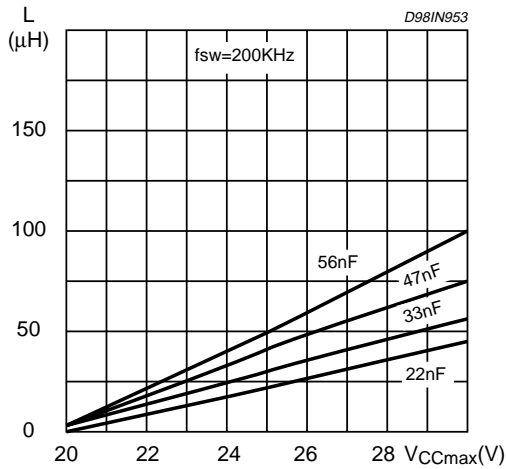
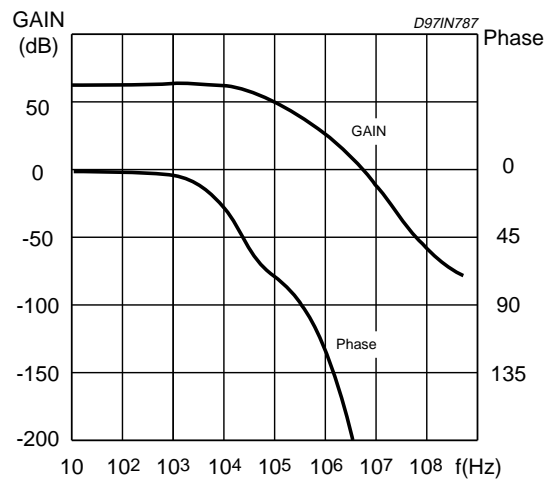
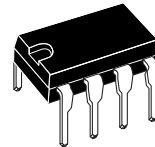

Figure 18. Open loop frequency and phase of error amplifier.



DIM.	mm			inch		
	MIN.	TYP.	MAX.	MIN.	TYP.	MAX.
A		3.32			0.131	
a1	0.51			0.020		
B	1.15		1.65	0.045		0.065
b	0.356		0.55	0.014		0.022
b1	0.204		0.304	0.008		0.012
D			10.92			0.430
E	7.95		9.75	0.313		0.384
e		2.54			0.100	
e3		7.62			0.300	
e4		7.62			0.300	
F			6.6			0.260
I			5.08			0.200
L	3.18		3.81	0.125		0.150
Z			1.52			0.060

OUTLINE AND MECHANICAL DATA



Minidip

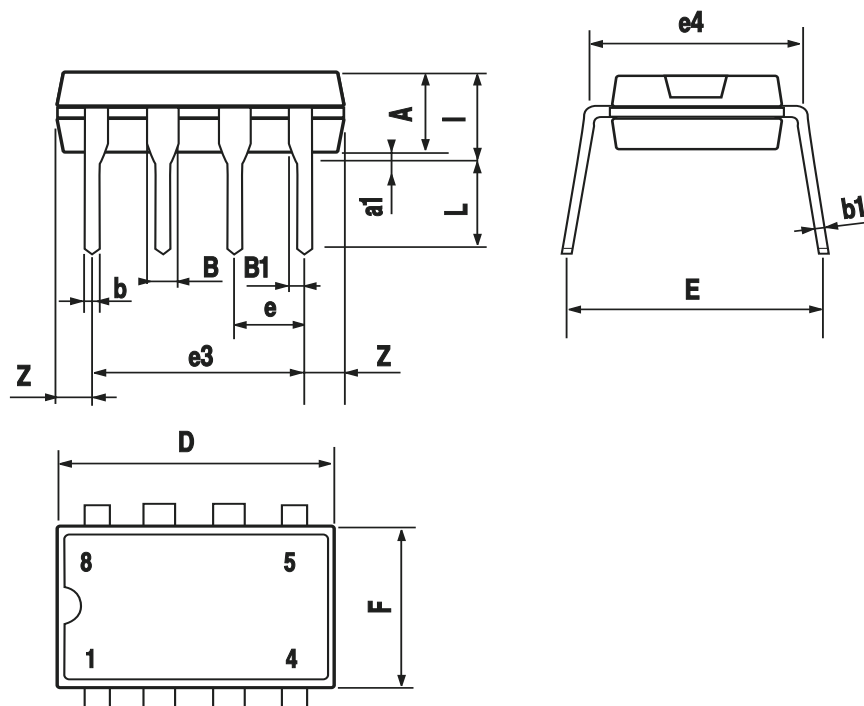

DIM.	mm			inch		
	MIN.	TYP.	MAX.	MIN.	TYP.	MAX.
A	2.35		2.65	0.093		0.104
A1	0.1		0.3	0.004		0.012
B	0.33		0.51	0.013		0.020
C	0.23		0.32	0.009		0.013
D	10.1		10.5	0.398		0.413
E	7.4		7.6	0.291		0.299
e		1.27			0.050	
H	10		10.65	0.394		0.419
h	0.25		0.75	0.010		0.030
L	0.4		1.27	0.016		0.050
K	0° (min.)8° (max.)					

OUTLINE AND MECHANICAL DATA

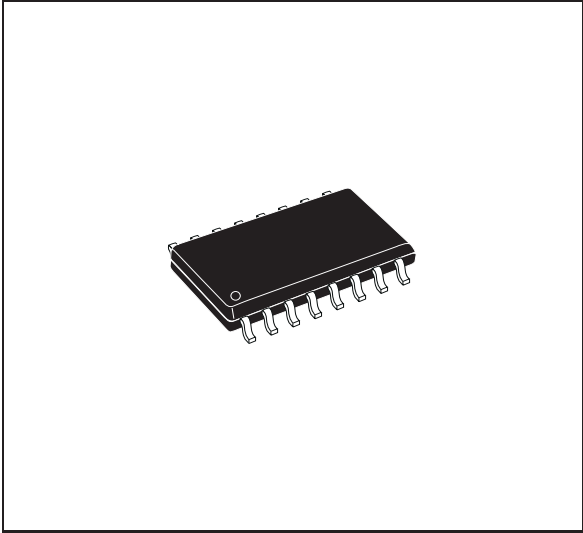

SO16 Wide

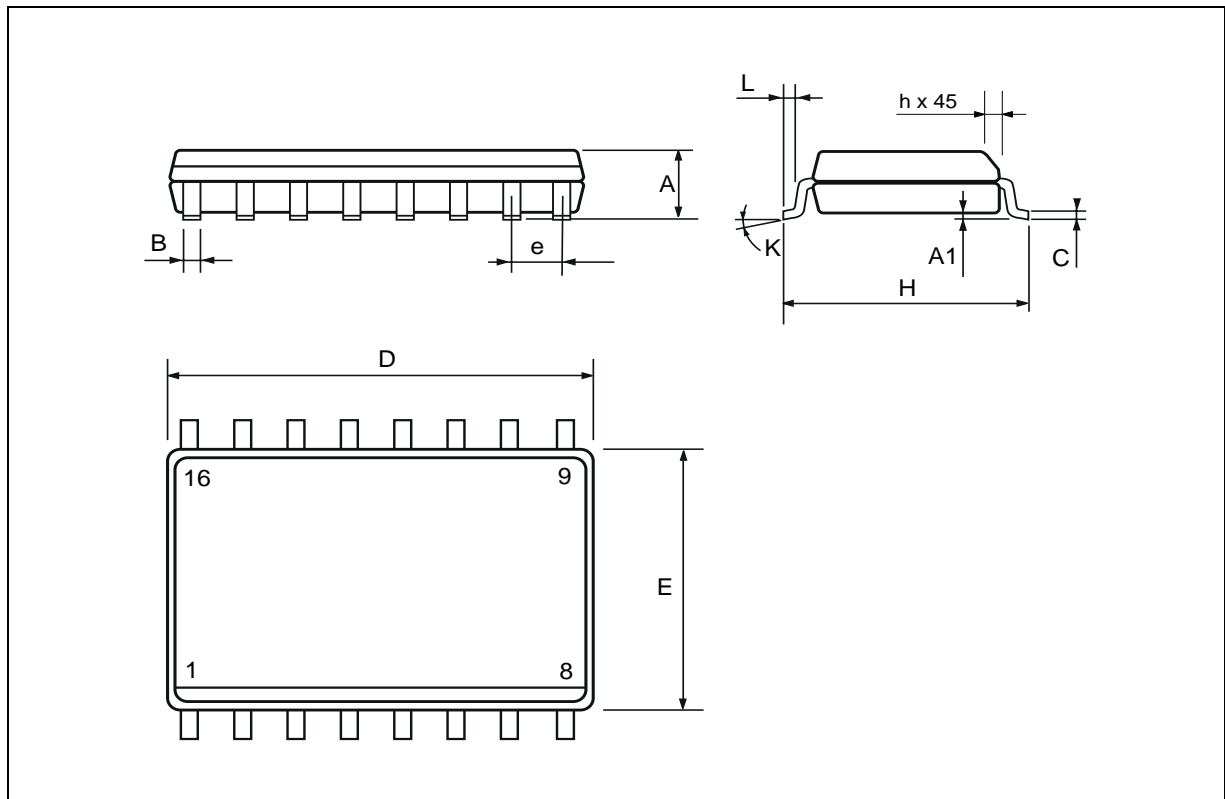

Information furnished is believed to be accurate and reliable. However, STMicroelectronics assumes no responsibility for the consequences of use of such information nor for any infringement of patents or other rights of third parties which may result from its use. No license is granted by implication or otherwise under any patent or patent rights of STMicroelectronics. Specification mentioned in this publication are subject to change without notice. This publication supersedes and replaces all information previously supplied. STMicroelectronics products are not authorized for use as critical components in life support devices or systems without express written approval of STMicroelectronics.

The ST logo is a registered trademark of STMicroelectronics

© 2001 STMicroelectronics – Printed in Italy – All Rights Reserved



STMicroelectronics GROUP OF COMPANIES

Australia - Brazil - China - Finland - France - Germany - Hong Kong - India - Italy - Japan - Malaysia - Malta - Morocco -
Singapore - Spain - Sweden - Switzerland - United Kingdom - U.S.A.

<http://www.st.com>

Looking for pricing, stock, or lifecycle information?

Click below to explore more details on WIN SOURCE:

-  [View L5971D on WIN SOURCE](#)
-  [STMicroelectronics Information](#)

Optimize Your Supply Chain with WIN SOURCE Solutions

-  Global Sourcing Solution
-  Obsolete Management
-  Cost Control Management
-  Shortage Management
-  Alternative Solution
-  Excess Inventory Management