

FEATURES

- **LOW COST MINIATURE PLASTIC PACKAGE (SOT-343)**
- **LOW NOISE FIGURE:**
0.6 dB typical at 2 GHz
- **HIGH ASSOCIATED GAIN:**
16.0 dB typical at 2 GHz
- **L_G = 0.6 μm, W_G = 400 μm**
- **TAPE & REEL PACKAGING**

DESCRIPTION

NEC's NE34018 is a low cost gallium arsenide Hetero-Junction FET housed in a miniature (SOT-343) plastic surface mount package. The device is fabricated using ion implantation for improved RF and DC performance, reliability, and uniformity. Its low noise figure, high gain, small size and weight make it an ideal low noise amplifier transistor in the 1-3 GHz frequency range. The NE34018 is suitable for GPS, PCS, WLAN, MMDS, and other commercial applications.

NEC's stringent quality assurance and test procedures ensure the highest reliability and performance.

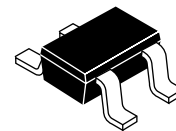
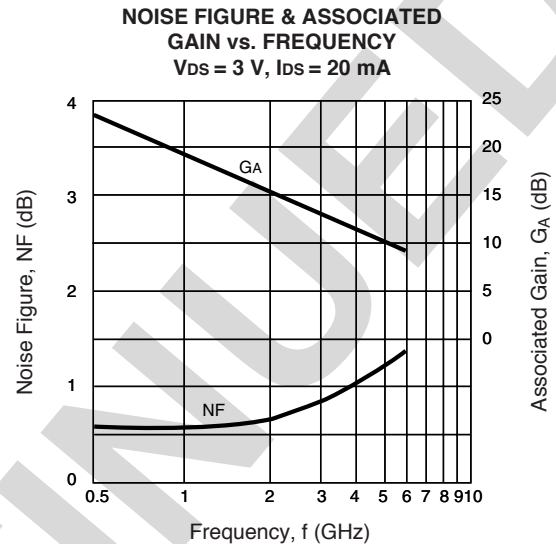

18 Package

SOT-343 Style

ELECTRICAL CHARACTERISTICS (T_A = 25°C)

PART NUMBER PACKAGE OUTLINE			NE34018 18		
SYMBOL	PARAMETERS AND CONDITIONS	UNITS	MIN	TYP	MAX
NF	Noise Figure at V _{DS} = 2 V, I _D = 5 mA, f = 2 GHz	dB		0.6	1.0
GA	Associated Gain at V _{DS} = 2 V, I _D = 5 mA, f = 2 GHz	dB	14.0	16.0	
P _{1dB}	Output Power at 1 dB Gain Compression Point, f = 2 GHz V _{DS} = 2 V, I _{DS} = 10 mA V _{DS} = 3 V, I _{DS} = 30 mA	dBm dBm		12 16.5	
G _{1dB}	Gain at P _{1dB} , f = 2 GHz V _{DS} = 2 V, I _{DS} = 10 mA V _{DS} = 3 V, I _{DS} = 30 mA	dB dB		17.0 17.5	
O/P I _{P3}	Output I _{P3} at f = 2 GHz, Δf = 1 MHz V _{DS} = 2 V, I _{DS} = 10 mA V _{DS} = 2 V, I _{DS} = 30 mA	dBm dBm		23 32	
I _{DSS}	Saturated Drain Current at V _{DS} = 2 V, V _{GS} = 0 V	mA	30	80	120
V _P	Pinch Off Voltage at V _{DS} = 2 V, I _D = 100 μA	V	-2.0	-0.8	-0.2
g _m	Transconductance at V _{DS} = 2 V, I _D = 5 mA	mS	30		
I _{GSO}	Gate to Source Leakage Current at V _{GS} = -3 V	μA		0.5	10
R _{TH(CH-A)}	Thermal Resistance (Channel to Ambient)	°C/W		833	

Note:

1. Typical values of noise figures and associated gain are those obtained when 50% of the devices from a large number of lots were individually measured in a circuit with the input individually tuned to obtain the minimum value. Maximum values are criteria established on the production line as a "go-no-go" screening test with the fixture tuned for the "generic" type but not for each specimen.

ABSOLUTE MAXIMUM RATINGS¹ (T_A = 25°C)

SYMBOLS	PARAMETERS	UNITS	RATINGS
V _{DS}	Drain to Source Voltage	V	4
V _{GDO}	Gate to Drain Voltage	V	-3
V _{GSO}	Gate to Source Voltage	V	-3
I _{DS}	Drain Current	mA	I _{DSS}
T _{CH}	Channel Temperature	°C	125
T _{STG}	Storage Temperature	°C	-65 to +125
P _T	Total Power Dissipation	mW	150

Note:

1. Operation in excess of any one of these parameters may result in permanent damage.

TYPICAL NOISE PARAMETERS (T_A = 25°C)

FREQ. (MHz)	NF _{OPT} (dB)	G _A (dB)	Γ _{OPT}		R _n /50
			MAG	ANG	
V_{DS} = 2 V, I_{DS} = 10 mA					
900	.56	20.5	.76	30	.45
2000	.63	16.3	.61	41	.28
2500	.68	14.1	.49	51	.18
3000	.70	13.6	.39	49	.16
3500	.76	12.3	.28	71	.12
4000	.82	11.6	.20	80	.10
V_{DS} = 2 V, I_{DS} = 30 mA					
2000	.60	17.0	.56	39	.23
2500	.70	15.3	.43	46	.15
3000	.76	14.2	.32	50	.26
V_{DS} = 3 V, I_{DS} = 20 mA					
900	.56	20.2	.74	26	1.54
2000	.62	16.8	.62	42	.43
2500	.66	14.9	.56	50	.31
3000	.70	14.0	.45	65	.24
3500	.80	13.2	.36	76	.14
4000	.84	12.8	.29	85	.10
4500	.90	11.0	.20	98	.08

TYPICAL PERFORMANCE CURVES (T_A = 25°C)

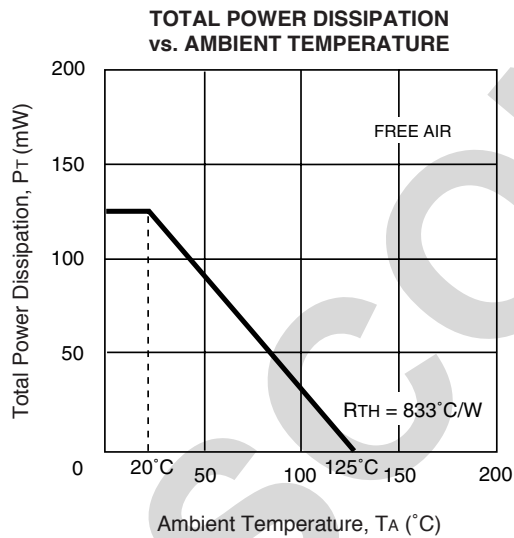

TYPICAL SCATTERING PARAMETERS (TA = 25°C)

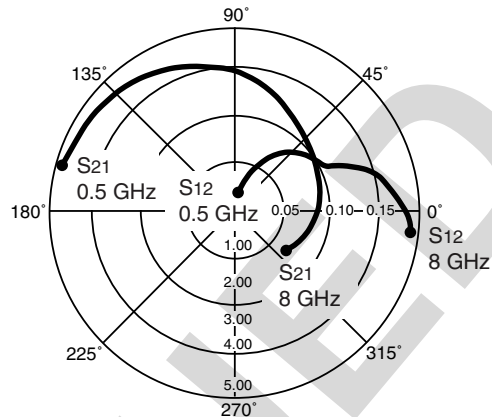
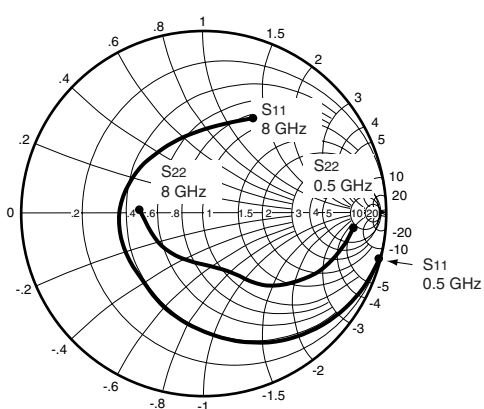

V_{DS} = 2 V, I_{DS} = 5 mA

FREQUENCY (GHz)	S ₁₁		S ₂₁		S ₁₂		S ₂₂		K	MAG ¹ (dB)
	MAG	ANG	MAG	ANG	MAG	ANG	MAG	ANG		
0.50	0.984	-15.1	4.945	165.0	0.020	80.6	0.807	-7.2	0.135	23.931
0.60	0.979	-18.0	4.908	162.3	0.023	78.9	0.803	-8.6	0.152	23.292
0.70	0.973	-21.0	4.899	159.4	0.027	77.0	0.798	-10.0	0.174	22.587
0.80	0.965	-23.9	4.871	156.7	0.031	75.3	0.793	-11.5	0.195	21.963
0.90	0.958	-26.8	4.843	153.9	0.034	73.7	0.788	-12.9	0.213	21.536
1.00	0.949	-29.8	4.825	151.1	0.038	72.1	0.781	-14.4	0.231	21.037
1.20	0.930	-35.7	4.783	145.6	0.045	68.7	0.767	-17.3	0.270	20.265
1.40	0.906	-41.5	4.723	140.2	0.052	65.4	0.751	-20.2	0.314	19.582
1.60	0.881	-47.5	4.660	134.7	0.058	62.2	0.734	-23.1	0.354	19.050
1.80	0.853	-53.6	4.605	129.3	0.064	59.1	0.715	-26.0	0.395	18.570
2.00	0.821	-59.8	4.531	123.8	0.070	56.0	0.696	-28.9	0.438	18.111
2.50	0.737	-76.3	4.332	110.5	0.082	48.2	0.648	-36.0	0.542	17.229
3.00	0.648	-94.2	4.092	97.6	0.092	41.4	0.600	-42.4	0.643	16.481
3.50	0.569	-113.6	3.805	85.3	0.098	35.3	0.556	-47.7	0.748	15.891
4.00	0.512	-133.0	3.516	73.9	0.102	30.5	0.518	-51.8	0.845	15.374
4.50	0.482	-150.9	3.248	63.8	0.105	27.2	0.480	-54.9	0.932	14.904
5.00	0.472	-165.2	3.025	54.7	0.108	25.3	0.444	-57.8	1.004	14.074
5.50	0.468	-175.7	2.846	46.4	0.112	24.5	0.405	-61.0	1.068	12.459
6.00	0.464	176.0	2.714	38.4	0.118	23.7	0.367	-65.4	1.107	11.622
6.50	0.456	167.9	2.601	30.5	0.126	22.4	0.331	-71.6	1.130	10.955
7.00	0.441	158.2	2.505	22.1	0.134	20.2	0.302	-80.8	1.149	10.372
7.50	0.422	144.3	2.417	13.3	0.142	18.0	0.283	-92.2	1.161	9.874
8.00	0.411	127.5	2.321	4.0	0.151	15.0	0.281	-105.9	1.152	9.503

Note:

1. Gain Calculations:

$$MAG = \frac{|S_{21}|}{|S_{12}|} (K \pm \sqrt{K^2 - 1})$$

When $K \leq 1$, MAG is undefined and MSG values are used. $MSG = \frac{|S_{21}|}{|S_{12}|}$, $K = \frac{1 + |\Delta|^2 - |S_{11}|^2 - |S_{22}|^2}{2 |S_{12} S_{21}|}$, $\Delta = S_{11} S_{22} - S_{21} S_{12}$

MAG = Maximum Available Gain

MSG = Maximum Stable Gain

TYPICAL SCATTERING PARAMETERS (TA = 25°C)

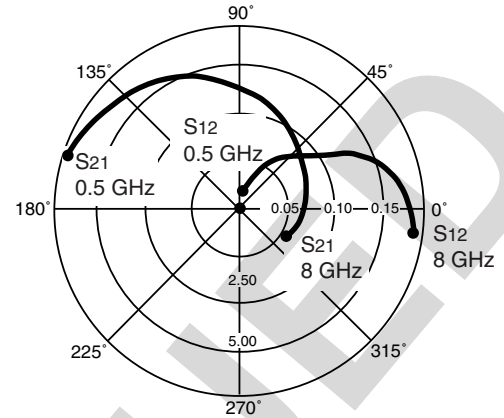
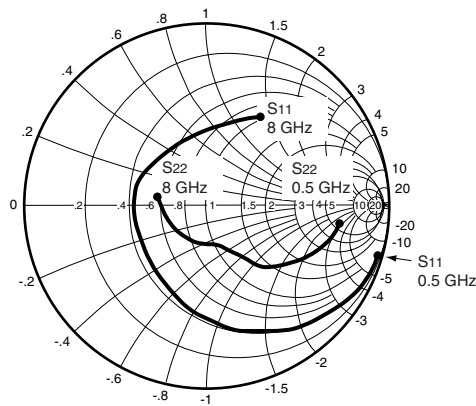

Vds = 2 V, Ids = 10 mA

FREQUENCY (GHz)	S11		S21		S12		S22		K	MAG ¹ (dB)
	MAG	ANG	MAG	ANG	MAG	ANG	MAG	ANG		
0.50	0.978	-17.0	6.806	162.8	0.018	80.1	0.723	-7.5	0.178	25.776
0.60	0.969	-20.3	6.731	159.7	0.022	78.7	0.719	-9.1	0.200	24.857
0.70	0.960	-23.6	6.691	156.5	0.025	77.3	0.712	-10.5	0.224	24.276
0.80	0.949	-26.9	6.624	153.4	0.028	75.5	0.706	-12.0	0.253	23.740
0.90	0.938	-30.1	6.559	150.3	0.032	73.6	0.698	-13.4	0.281	23.117
1.00	0.924	-33.3	6.502	147.2	0.035	72.4	0.690	-14.9	0.307	22.690
1.20	0.897	-39.8	6.371	141.2	0.041	69.2	0.673	-17.8	0.356	21.914
1.40	0.865	-46.0	6.217	135.3	0.047	66.3	0.655	-20.6	0.410	21.215
1.60	0.831	-52.4	6.065	129.5	0.053	63.4	0.635	-23.4	0.460	20.586
1.80	0.796	-58.7	5.912	123.9	0.058	60.7	0.614	-26.1	0.509	20.083
2.00	0.757	-65.1	5.750	118.3	0.063	58.1	0.594	-28.8	0.560	19.603
2.50	0.658	-81.9	5.336	105.0	0.074	51.7	0.546	-35.3	0.677	18.580
3.00	0.563	-100.1	4.909	92.4	0.083	46.5	0.501	-41.2	0.782	17.719
3.50	0.483	-119.7	4.478	80.8	0.091	41.8	0.463	-45.9	0.873	16.920
4.00	0.432	-139.4	4.080	70.2	0.097	38.1	0.429	-49.5	0.952	16.239
4.50	0.409	-157.2	3.733	60.8	0.103	35.1	0.388	-53.3	1.018	14.771
5.00	0.406	-171.0	3.448	52.3	0.109	33.2	0.363	-53.8	1.057	13.538
5.50	0.408	179.2	3.223	44.5	0.117	31.6	0.327	-55.6	1.085	12.618
6.00	0.411	171.4	3.050	37.0	0.126	29.9	0.293	-58.3	1.097	11.939
6.50	0.408	163.8	2.906	29.4	0.136	27.5	0.259	-62.8	1.106	11.320
7.00	0.397	154.5	2.782	21.5	0.145	24.1	0.232	-71.3	1.117	10.752
7.50	0.383	140.6	2.672	13.2	0.156	20.8	0.211	-83.2	1.112	10.298
8.00	0.376	123.6	2.560	4.4	0.166	16.5	0.204	-99.5	1.104	9.917

Note:

1. Gain Calculations:

$$MAG = \frac{|S_{21}|}{|S_{12}|} (K \pm \sqrt{K^2 - 1}). \text{ When } K \leq 1, \text{ MAG is undefined and MSG values are used. } MSG = \frac{|S_{21}|}{|S_{12}|}, K = \frac{1 + |\Delta|^2 - |S_{11}|^2 - |S_{22}|^2}{2 |S_{12} S_{21}|}, \Delta = S_{11} S_{22} - S_{21} S_{12}$$

MAG = Maximum Available Gain

MSG = Maximum Stable Gain

TYPICAL SCATTERING PARAMETERS ($T_A = 25^\circ\text{C}$)**V_{DS} = 2 V, I_{DS} = 20 mA**

FREQUENCY (GHz)	S ₁₁		S ₂₁		S ₁₂		S ₂₂		K	MAG ¹ (dB)
	MAG	ANG	MAG	ANG	MAG	ANG	MAG	ANG		
0.50	0.969	-18.6	8.533	160.8	0.017	81.2	0.635	-7.3	0.221	27.007
0.60	0.958	-22.1	8.416	157.3	0.020	79.4	0.631	-8.8	0.256	26.241
0.70	0.946	-25.7	8.331	153.8	0.023	77.8	0.624	-10.2	0.289	25.590
0.80	0.931	-29.2	8.211	150.4	0.026	76.4	0.617	-11.6	0.324	24.994
0.90	0.916	-32.7	8.092	147.1	0.029	75.1	0.610	-12.9	0.354	24.457
1.00	0.899	-36.1	7.982	143.7	0.032	73.8	0.601	-14.3	0.387	23.970
1.20	0.864	-42.9	7.737	137.3	0.037	71.1	0.584	-16.9	0.451	23.204
1.40	0.825	-49.3	7.469	131.1	0.043	68.5	0.566	-19.4	0.512	22.398
1.60	0.785	-55.8	7.205	125.2	0.048	66.1	0.547	-21.8	0.570	21.764
1.80	0.745	-62.1	6.948	119.5	0.053	63.8	0.527	-24.2	0.623	21.176
2.00	0.701	-68.6	6.692	113.9	0.058	61.7	0.509	-26.5	0.675	20.621
2.50	0.596	-85.3	6.075	100.9	0.069	56.6	0.467	-32.4	0.786	19.447
3.00	0.499	-103.3	5.495	88.9	0.079	52.0	0.428	-37.8	0.879	18.423
3.50	0.422	-123.1	4.953	77.8	0.088	47.9	0.397	-42.4	0.952	17.504
4.00	0.374	-142.9	4.477	67.8	0.096	44.3	0.369	-45.8	1.009	16.118
4.50	0.357	-160.6	4.073	58.9	0.104	41.1	0.340	-47.7	1.047	14.596
5.00	0.359	-174.1	3.745	50.9	0.112	38.6	0.310	-48.8	1.073	13.589
5.50	0.366	176.6	3.487	43.4	0.122	36.2	0.278	-49.1	1.084	12.796
6.00	0.372	169.3	3.285	36.2	0.133	33.6	0.248	-50.0	1.084	12.160
6.50	0.372	162.1	3.118	29.0	0.144	30.4	0.219	-52.7	1.086	11.571
7.00	0.365	153.0	2.975	21.4	0.154	26.4	0.193	-60.2	1.090	11.031
7.50	0.353	139.1	2.852	13.4	0.165	22.2	0.169	-72.2	1.088	10.569
8.00	0.348	122.0	2.729	5.0	0.176	17.4	0.156	-91.3	1.079	10.189

Note:

1. Gain Calculations:

$$\text{MAG} = \frac{|S_{21}|}{|S_{12}|} (K \pm \sqrt{K^2 - 1}). \text{ When } K \leq 1, \text{ MAG is undefined and MSG values are used. } \text{MSG} = \frac{|S_{21}|}{|S_{12}|}, K = \frac{1 + |\Delta|^2 - |S_{11}|^2 - |S_{22}|^2}{2 |S_{12} S_{21}|}, \Delta = S_{11} S_{22} - S_{21} S_{12}$$

MAG = Maximum Available Gain

MSG = Maximum Stable Gain

TYPICAL SCATTERING PARAMETERS (TA = 25 °C)

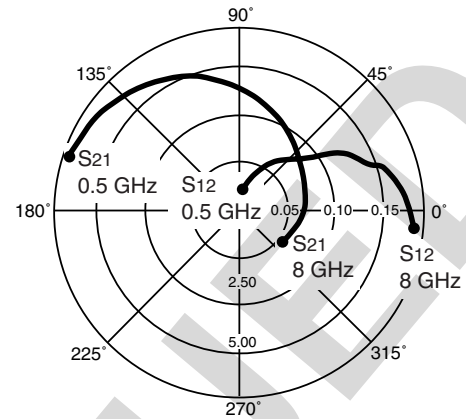
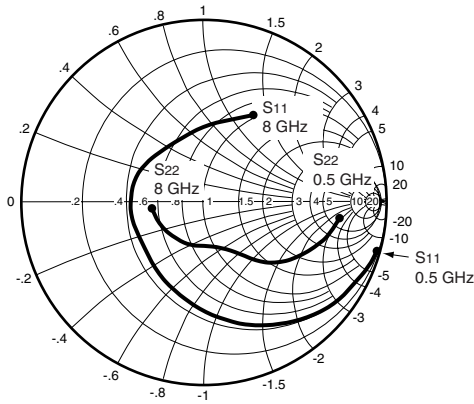

Vds = 3 V, Ids = 10 mA

FREQUENCY (GHz)	S11		S21		S12		S22		K	MAG ¹ (dB)
	MAG	ANG	MAG	ANG	MAG	ANG	MAG	ANG		
0.50	0.977	-17.0	6.912	162.9	0.018	80.5	0.744	-7.5	0.170	25.843
0.60	0.969	-20.2	6.836	159.7	0.021	79.0	0.740	-9.0	0.194	25.126
0.70	0.959	-23.5	6.795	156.5	0.024	77.1	0.733	-10.4	0.226	24.520
0.80	0.948	-26.8	6.728	153.4	0.027	75.4	0.727	-11.9	0.252	23.965
0.90	0.937	-30.0	6.659	150.3	0.031	73.7	0.719	-13.3	0.278	23.320
1.00	0.923	-33.2	6.602	147.2	0.034	72.4	0.712	-14.8	0.302	22.882
1.20	0.895	-39.6	6.467	141.2	0.040	69.1	0.695	-17.6	0.355	22.086
1.40	0.863	-45.8	6.310	135.3	0.045	66.2	0.676	-20.3	0.410	21.468
1.60	0.829	-52.1	6.152	129.5	0.051	63.5	0.656	-23.0	0.459	20.814
1.80	0.793	-58.4	5.996	123.9	0.056	60.8	0.636	-25.7	0.508	20.297
2.00	0.754	-64.8	5.830	118.3	0.061	58.0	0.616	-28.3	0.559	19.803
2.50	0.656	-81.4	5.407	105.1	0.071	52.1	0.568	-34.6	0.674	18.817
3.00	0.559	-99.2	4.973	92.7	0.080	46.7	0.524	-40.1	0.781	17.935
3.50	0.479	-118.5	4.538	81.1	0.087	42.3	0.486	-44.7	0.876	17.173
4.00	0.426	-138.0	4.138	70.6	0.093	38.9	0.454	-48.2	0.953	16.483
4.50	0.402	-155.8	3.788	61.2	0.099	36.4	0.422	-50.6	1.011	15.173
5.00	0.397	-169.6	3.500	52.8	0.105	34.6	0.389	-52.6	1.058	13.757
5.50	0.399	-179.6	3.274	45.0	0.112	33.3	0.355	-54.6	1.090	12.833
6.00	0.401	172.6	3.101	37.6	0.121	31.8	0.322	-57.5	1.100	12.163
6.50	0.399	165.2	2.956	30.1	0.131	29.6	0.290	-62.2	1.104	11.573
7.00	0.389	156.1	2.832	22.3	0.140	26.6	0.264	-70.4	1.112	11.026
7.50	0.387	144.7	2.798	15.4	0.153	20.4	0.245	-81.6	1.063	11.085
8.00	0.365	125.8	2.614	5.4	0.161	19.3	0.240	-96.5	1.094	10.240

Note:

1. Gain Calculations:

$$MAG = \frac{|S_{21}|}{|S_{12}|} (K \pm \sqrt{K^2 - 1})$$

When $K \leq 1$, MAG is undefined and MSG values are used. $MSG = \frac{|S_{21}|}{|S_{12}|}$, $K = \frac{1 + |\Delta|^2 - |S_{11}|^2 - |S_{22}|^2}{2 |S_{12} S_{21}|}$, $\Delta = S_{11} S_{22} - S_{21} S_{12}$

MAG = Maximum Available Gain

MSG = Maximum Stable Gain

TYPICAL SCATTERING PARAMETERS (TA = 25 °C)

Vds = 3 V, Ids = 20 mA

FREQUENCY (GHz)	S11		S21		S12		S22		K	MAG ¹ (dB)
	MAG	ANG	MAG	ANG	MAG	ANG	MAG	ANG		
0.500	0.969	-18.7	8.662	160.8	0.016	81.1	0.667	-7.3	0.215	27.335
0.600	0.957	-22.2	8.541	157.3	0.019	79.1	0.663	-8.8	0.255	26.528
0.700	0.945	-25.8	8.454	153.7	0.022	78.0	0.655	-10.2	0.282	25.846
0.800	0.930	-29.3	8.332	150.3	0.025	76.3	0.649	-11.6	0.318	25.228
0.900	0.915	-32.7	8.209	147.0	0.028	74.8	0.641	-12.9	0.350	24.671
1.000	0.898	-36.1	8.096	143.6	0.031	73.3	0.632	-14.3	0.384	24.169
1.200	0.862	-42.8	7.844	137.2	0.036	70.6	0.615	-16.9	0.447	23.382
1.400	0.823	-49.3	7.571	131.1	0.041	68.1	0.596	-19.3	0.509	22.664
1.600	0.781	-55.7	7.299	125.1	0.046	65.7	0.577	-21.7	0.569	22.005
1.800	0.741	-62.0	7.036	119.4	0.051	63.5	0.557	-24.0	0.621	21.398
2.000	0.697	-68.4	6.775	113.9	0.056	61.4	0.539	-26.4	0.670	20.827
2.250	0.644	-76.6	6.458	107.2	0.061	58.7	0.517	-29.3	0.731	20.248
2.500	0.591	-84.9	6.144	100.9	0.066	56.5	0.496	-32.0	0.786	19.689
2.750	0.541	-93.7	5.848	94.8	0.071	54.3	0.476	-34.7	0.833	19.157
3.000	0.493	-102.7	5.553	88.9	0.075	52.1	0.458	-37.1	0.884	18.695
3.500	0.415	-122.2	5.007	78.0	0.084	48.2	0.426	-41.5	0.956	17.753
4.000	0.368	-141.9	4.526	68.0	0.091	44.9	0.399	-44.7	1.016	16.188
4.500	0.349	-159.7	4.119	59.2	0.099	42.2	0.372	-46.8	1.052	14.798
5.000	0.349	-173.2	3.790	51.2	0.107	39.9	0.343	-48.1	1.077	13.794
5.500	0.357	177.4	3.532	43.8	0.116	37.9	0.313	-49.1	1.089	13.021
6.000	0.362	170.2	3.332	36.7	0.127	35.6	0.284	-50.8	1.086	12.405
6.500	0.363	163.3	3.166	29.5	0.138	32.7	0.255	-54.2	1.084	11.836
7.000	0.356	154.4	3.024	22.0	0.148	28.8	0.230	-61.8	1.087	11.307
7.500	0.343	140.7	2.902	14.1	0.160	25.0	0.208	-73.1	1.079	10.876
8.000	0.336	123.7	2.782	5.7	0.171	20.3	0.199	-89.6	1.067	10.531

Note:

1. Gain Calculations:

$$\text{MAG} = \frac{|S_{21}|}{|S_{12}|} (K \pm \sqrt{K^2 - 1}). \text{ When } K \leq 1, \text{ MAG is undefined and MSG values are used. } \text{MSG} = \frac{|S_{21}|}{|S_{12}|}, K = \frac{1 + |\Delta|^2 - |S_{11}|^2 - |S_{22}|^2}{2 |S_{12} S_{21}|}, \Delta = S_{11} S_{22} - S_{21} S_{12}$$

MAG = Maximum Available Gain

MSG = Maximum Stable Gain

SCHEMATIC

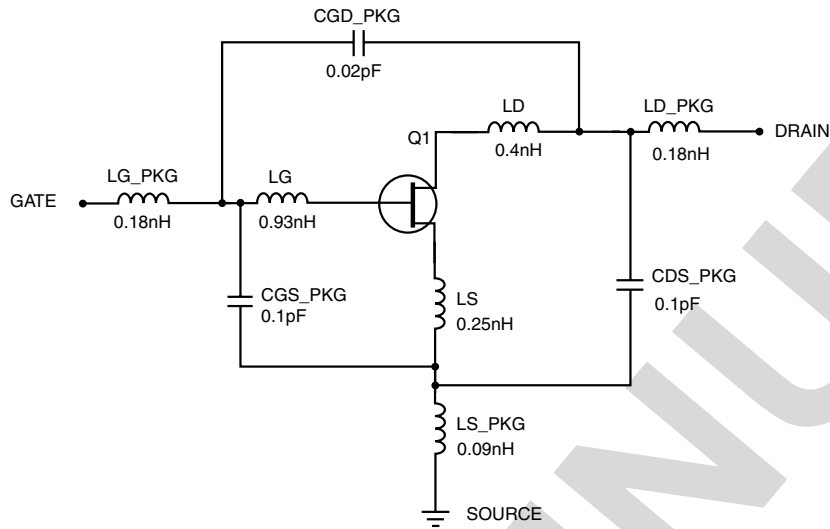

FET NONLINEAR MODEL PARAMETERS (1)

UNITS

Parameters	Q1	Parameters	Q1
VTO	-0.6885	RG	4
VTOSC	0	RD	1.5
ALPHA	5	RS	2
BETA	0.1838	RGMET	0
GAMMA	0.038	KF	0
GAMMADC	0.03	AF	1
Q	1.8	TNOM	27
DELTA	0.25	XTI	3
VBI	0.7	EG	1.43
IS	3e-13	VTOTC	0
N	1	BETATCE	0
RIS	0	FFE	1
RID	0		
TAU	4e-12		
CDS	0.1e-12		
RDB	5000		
CBS	1e-11		
CGSO	0.95e-12		
CGDO	0.04e-12		
DELTA1	0.3		
DELTA2	0.05		
FC	0.5		
VBR	Infinity		

Parameter	Units
time	seconds
capacitance	farads
inductance	henries
resistance	ohms
voltage	volts
current	amps

MODEL RANGE

Frequency: 0.5 to 6 GHz
 Bias: $V_{DS} = 1\text{ V to }3\text{ V}$, $I_D = 5\text{ mA to }40\text{ mA}$
 Date: 6/97

(1) Series IV Libra TOM Model

OUTLINE DIMENSIONS (Units in mm)

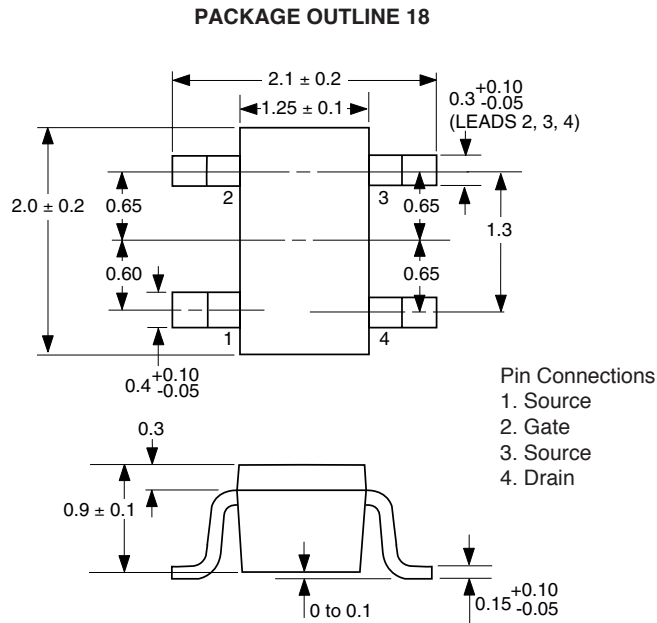

ORDERING INFORMATION

PART NUMBER	QTY	I _{DSS} RANGE (mA)	MARKING
NE34018-A	Bulk up to 3 K	30-120	V63 or V64
NE34018-TI-63-A	3 K/Reel	30-65	V63
NE34018-TI-64-A	3 K/Reel	60-120	V64

Life Support Applications

These NEC products are not intended for use in life support devices, appliances, or systems where the malfunction of these products can reasonably be expected to result in personal injury. The customers of CEL using or selling these products for use in such applications do so at their own risk and agree to fully indemnify CEL for all damages resulting from such improper use or sale.

EXCLUSIVE NORTH AMERICAN AGENT FOR **NEC** RF, MICROWAVE & OPTOELECTRONIC SEMICONDUCTORS

CEL CALIFORNIA EASTERN LABORATORIES • Headquarters • 4590 Patrick Henry Drive • Santa Clara, CA 95054-1817 • (408) 988-3500 • Telex 34-6393 • FAX (408) 988-0279

24-Hour Fax-On-Demand: 800-390-3232 (U.S. and Canada only) • Internet: <http://WWW.CEL.COM>

DATA SUBJECT TO CHANGE WITHOUT NOTICE

♻️ PRINTED IN USA ON RECYCLED PAPER - 12/98

Subject: Compliance with EU Directives

CEL certifies, to its knowledge, that semiconductor and laser products detailed below are compliant with the requirements of European Union (EU) Directive 2002/95/EC Restriction on Use of Hazardous Substances in electrical and electronic equipment (RoHS) and the requirements of EU Directive 2003/11/EC Restriction on Penta and Octa BDE.

CEL Pb-free products have the same base part number with a suffix added. The suffix –A indicates that the device is Pb-free. The –AZ suffix is used to designate devices containing Pb which are exempted from the requirement of RoHS directive (*). In all cases the devices have Pb-free terminals. All devices with these suffixes meet the requirements of the RoHS directive.

This status is based on CEL’s understanding of the EU Directives and knowledge of the materials that go into its products as of the date of disclosure of this information.

Restricted Substance per RoHS	Concentration Limit per RoHS (values are not yet fixed)	Concentration contained in CEL devices	
		-A	-AZ
Lead (Pb)	< 1000 PPM	Not Detected	(*)
Mercury	< 1000 PPM	Not Detected	
Cadmium	< 100 PPM	Not Detected	
Hexavalent Chromium	< 1000 PPM	Not Detected	
PBB	< 1000 PPM	Not Detected	
PBDE	< 1000 PPM	Not Detected	

If you should have any additional questions regarding our devices and compliance to environmental standards, please do not hesitate to contact your local representative.

Important Information and Disclaimer: Information provided by CEL on its website or in other communications concerning the substance content of its products represents knowledge and belief as of the date that it is provided. CEL bases its knowledge and belief on information provided by third parties and makes no representation or warranty as to the accuracy of such information. Efforts are underway to better integrate information from third parties. CEL has taken and continues to take reasonable steps to provide representative and accurate information but may not have conducted destructive testing or chemical analysis on incoming materials and chemicals. CEL and CEL suppliers consider certain information to be proprietary, and thus CAS numbers and other limited information may not be available for release.

In no event shall CEL’s liability arising out of such information exceed the total purchase price of the CEL part(s) at issue sold by CEL to customer on an annual basis.

See CEL Terms and Conditions for additional clarification of warranties and liability.

Looking for pricing, stock, or lifecycle information?

Click below to explore more details on WIN SOURCE:

 [View NE34018-T1-64-A on WIN SOURCE](#)

 [CEL Information](#)

Optimize Your Supply Chain with WIN SOURCE Solutions

-  Global Sourcing Solution
-  Obsolete Management
-  Cost Control Management
-  Shortage Management
-  Alternative Solution
-  Excess Inventory Management