



**THE DATASHEET OF
NCP1086T-ADJG**



NCP1086

1.5 A Adjustable and 3.3 V Fixed Output Linear Regulator

The NCP1086 linear regulator provides 1.5 A at 3.3 V or adjustable output voltage. The adjustable output voltage device uses two external resistors to set the output voltage within a 1.25 V to 5.5 V range.

The regulators is intended for use as post regulator and microprocessor supply. The fast loop response and low dropout voltage make this regulator ideal for applications where low voltage operation and good transient response are important.

The circuit is designed to operate with dropout voltages less than 1.4 V at 1.5 A output current. Device protection includes overcurrent and thermal shutdown.

This device is pin compatible with LT1086 family of linear regulators and has lower dropout voltage.

The regulators are available in TO-220-3, surface mount D²PAK-3, and SOT-223 packages.

Features

- Output Current to 1.5 A
- Output Accuracy to $\pm 1\%$ Over Temperature
- Dropout Voltage (Typical) 1.05 V @ 1.5 A
- Fast Transient Response
- Fault Protection Circuitry
 - ◆ Current Limit
 - ◆ Thermal Shutdown
- Pb-Free Packages are Available



ON Semiconductor®

<http://onsemi.com>

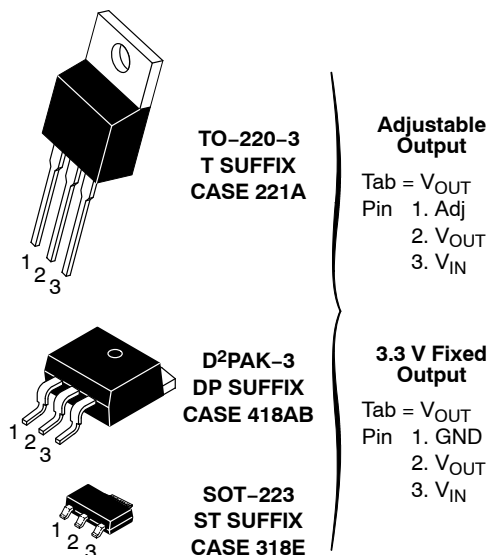

ORDERING INFORMATION

See detailed ordering and shipping information in the package dimensions section on page 9 of this data sheet.

DEVICE MARKING INFORMATION

See general marking information in the device marking section on page 10 of this data sheet.

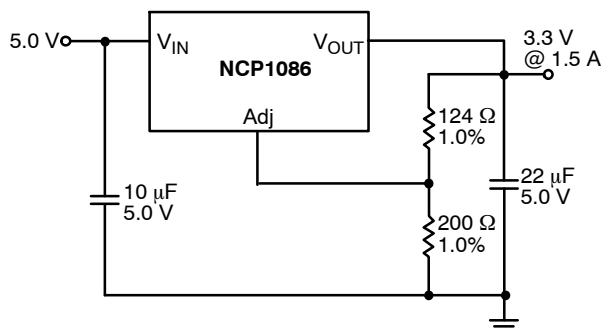

Figure 1. Application Diagram, Adjustable Output

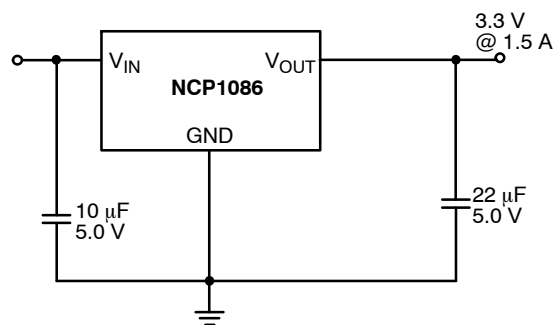

Figure 2. Application Diagram, 3.3 V Fixed Output

NCP1086

MAXIMUM RATINGS*

Parameter	Value	Unit	
Supply Voltage, V_{CC}	7.0	V	
Operating Temperature Range	-40 to +70	°C	
Junction Temperature	150	°C	
Storage Temperature Range	-60 to +150	°C	
Lead Temperature Soldering:	Wave Solder (through hole styles only) Note 1 Reflow (SMD styles only) Note 2	260 Peak 230 Peak	°C
ESD Damage Threshold	2.0	kV	

Stresses exceeding Maximum Ratings may damage the device. Maximum Ratings are stress ratings only. Functional operation above the Recommended Operating Conditions is not implied. Extended exposure to stresses above the Recommended Operating Conditions may affect device reliability.

- 10 second maximum.
- 60 second maximum above 183°C.

ELECTRICAL CHARACTERISTICS ($C_{IN} = 10 \mu\text{F}$, $C_{OUT} = 22 \mu\text{F}$ Tantalum, $V_{OUT} + V_{DROPOUT} < V_{IN} < 7.0 \text{ V}$, $0^\circ\text{C} \leq T_A \leq 70^\circ\text{C}$, $T_J \leq +150^\circ\text{C}$, unless otherwise specified, $I_{full load} = 1.5 \text{ A}$.)

Characteristic	Test Conditions	Min	Typ	Max	Unit
----------------	-----------------	-----	-----	-----	------

ADJUSTABLE OUTPUT VOLTAGE

Reference Voltage (Notes 3 and 4)	$V_{IN} - V_{OUT} = 1.5 \text{ V}$; $V_{Adj} = 0 \text{ V}$, $10 \text{ mA} \leq I_{OUT} \leq 1.5 \text{ A}$	1.241 (-1%)	1.254	1.266 (+1%)	V
Line Regulation	$1.5 \text{ V} \leq V_{IN} - V_{OUT} \leq 5.75 \text{ V}$; $I_{OUT} = 10 \text{ mA}$	-	0.02	0.2	%
Load Regulation (Notes 3 and 4)	$V_{IN} - V_{OUT} = 1.5 \text{ V}$; $10 \text{ mA} \leq I_{OUT} \leq 1.5 \text{ A}$	-	0.04	0.4	%
Dropout Voltage (Note 5)	$I_{OUT} = 1.5 \text{ A}$	-	1.05	1.4	V
Current Limit	$V_{IN} - V_{OUT} = 3.0 \text{ V}$; $T_J \geq 25^\circ\text{C}$	1.6	3.1	-	A
Minimum Load Current (Note 6)	$V_{IN} = 7.0 \text{ V}$; $V_{Adj} = 0$	-	0.6	2.0	mA
Adjust Pin Current	$V_{IN} - V_{OUT} = 3.0 \text{ V}$; $I_{OUT} = 10 \text{ mA}$	-	50	100	μA
Thermal Regulation (Note 7)	30 ms pulse; $T_A = 25^\circ\text{C}$	-	0.002	0.02	%/W
Ripple Rejection (Note 7)	$f = 120 \text{ Hz}$; $I_{OUT} = 1.5 \text{ A}$; $V_{IN} - V_{OUT} = 3.0 \text{ V}$; $V_{RIPPLE} = 1.0 V_{P-P}$	-	80	-	dB
Thermal Shutdown (Note 8)	-	150	180	210	°C
Thermal Shutdown Hysteresis (Note 8)	-	-	25	-	°C

FIXED OUTPUT VOLTAGE

Output Voltage (Notes 3 and 4)	$V_{IN} - V_{OUT} = 1.5 \text{ V}$, $0 \leq I_{OUT} \leq 1.5 \text{ A}$	3.25 (-1.5%)	3.3	3.35 (+1.5%)	V
Line Regulation	$2.0 \text{ V} \leq V_{IN} - V_{OUT} \leq 3.7 \text{ V}$; $I_{OUT} = 10 \text{ mA}$	-	0.02	0.2	%
Load Regulation (Notes 3 and 4)	$V_{IN} - V_{OUT} = 2.0 \text{ V}$; $10 \text{ mA} \leq I_{OUT} \leq 1.5 \text{ A}$	-	0.04	0.4	%
Dropout Voltage (Note 5)	$I_{OUT} = 1.5 \text{ A}$	-	1.05	1.4	V
Current Limit	$V_{IN} - V_{OUT} = 3.0 \text{ V}$	1.6	3.1	-	A
Quiescent Current	$I_{OUT} = 10 \text{ mA}$	-	5.0	10	mA
Thermal Regulation (Note 7)	30 ms pulse; $T_A = 25^\circ\text{C}$	-	0.002	0.02	%/W

- Load regulation and output voltage are measured at a constant junction temperature by low duty cycle pulse testing. Changes in output voltage due to thermal gradients or temperature changes must be taken into account separately.
- Specifications apply for an external Kelvin sense connection at a point on the output pin 1/4" from the bottom of the package.
- Dropout voltage is a measurement of the minimum input/output differential at full load.
- The minimum load current is the minimum current required to maintain regulation. Normally the current in the resistor divider used to set the output voltage is selected to meet the minimum requirement.
- Guaranteed by design, not 100% tested in production.
- Thermal shutdown is 100% functionally tested in production.

NCP1086

ELECTRICAL CHARACTERISTICS (continued) ($C_{IN} = 10 \mu\text{F}$, $C_{OUT} = 22 \mu\text{F}$ Tantalum, $V_{OUT} + V_{DROPOUT} < V_{IN} < 7.0 \text{ V}$, $0^\circ\text{C} \leq T_A \leq 70^\circ\text{C}$, $T_J \leq +150^\circ\text{C}$, unless otherwise specified, $I_{full\ load} = 1.5 \text{ A}$.)

Characteristic	Test Conditions	Min	Typ	Max	Unit
FIXED OUTPUT VOLTAGE (continued)					
Ripple Rejection (Note 9)	$f = 120 \text{ Hz}$; $I_{OUT} = 1.5 \text{ A}$; $V_{IN} - V_{OUT} = 3.0 \text{ V}$; $V_{RIPPLE} = 1.0 \text{ V}_{P-P}$	-	80	-	dB
Thermal Shutdown (Note 10)	-	150	180	210	$^\circ\text{C}$
Thermal Shutdown Hysteresis (Note 10)	-	-	25	-	$^\circ\text{C}$

9. Guaranteed by design, not 100% tested in production.
10. Thermal shutdown is 100% functionally tested in production.

PACKAGE PIN DESCRIPTION, ADJUSTABLE OUTPUT

Package Pin Number			Pin Symbol	Function
D ² PAK-3	TO-220-3	SOT-223		
1	1	1	Adj	Adjust pin (low side of the internal reference).
2	2	2	V_{OUT}	Regulated output voltage (case).
3	3	3	V_{IN}	Input voltage.

PACKAGE PIN DESCRIPTION, 3.3 V FIXED OUTPUT

Package Pin Number			Pin Symbol	Function
D ² PAK-3	TO-220-3	SOT-223		
1	1	1	GND	Ground connection.
2	2	2	V_{OUT}	Regulated output voltage (case).
3	3	3	V_{IN}	Input voltage.

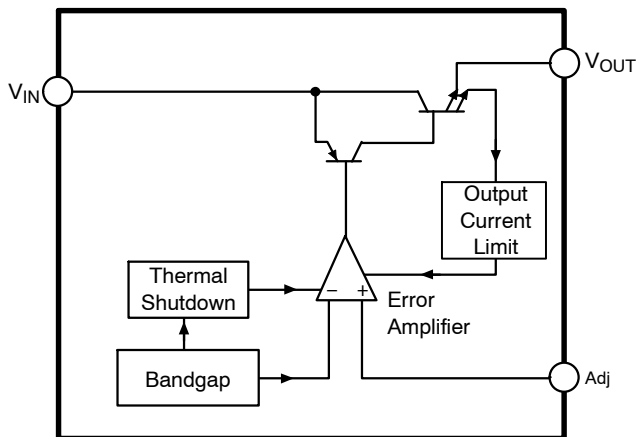

Figure 3. Block Diagram, Adjustable Output

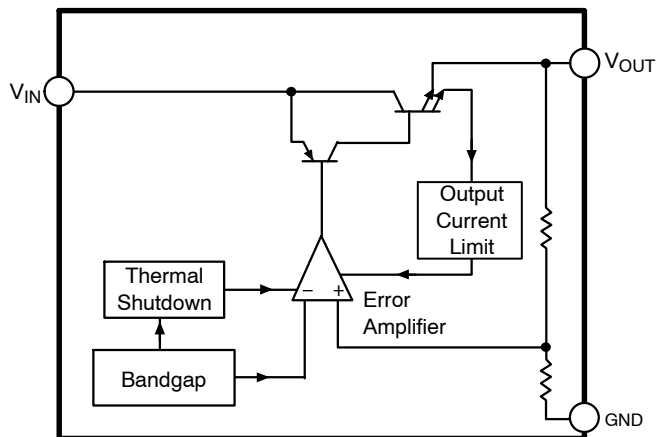

Figure 4. Block Diagram, 3.3 V Fixed Output

TYPICAL PERFORMANCE CHARACTERISTICS

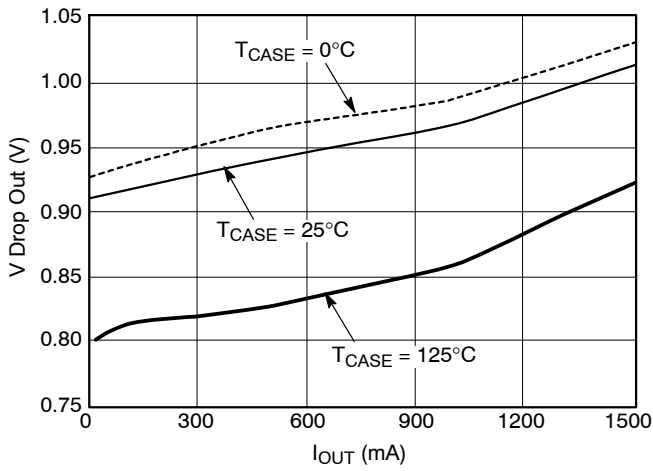

Figure 5. Dropout Voltage vs. Output Current

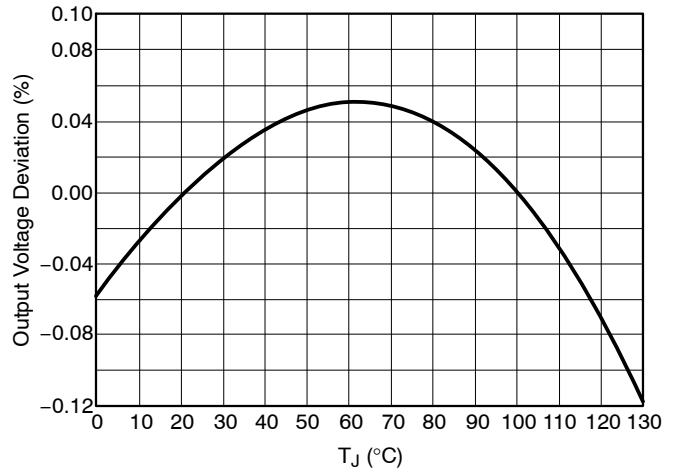

Figure 6. Reference Voltage vs. Temperature

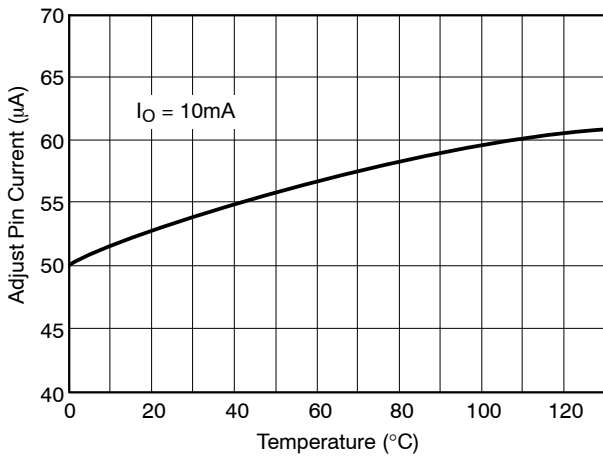

Figure 7. Adjust Pin Current vs. Temperature (Adjustable Output)

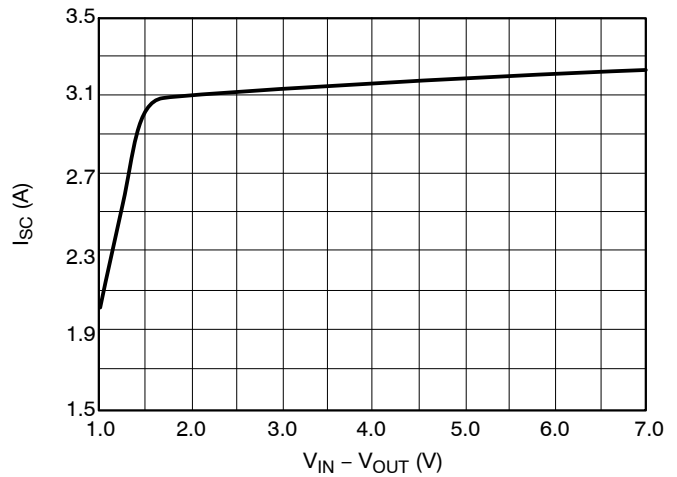

Figure 8. Short Circuit Current vs. $V_{IN} - V_{OUT}$

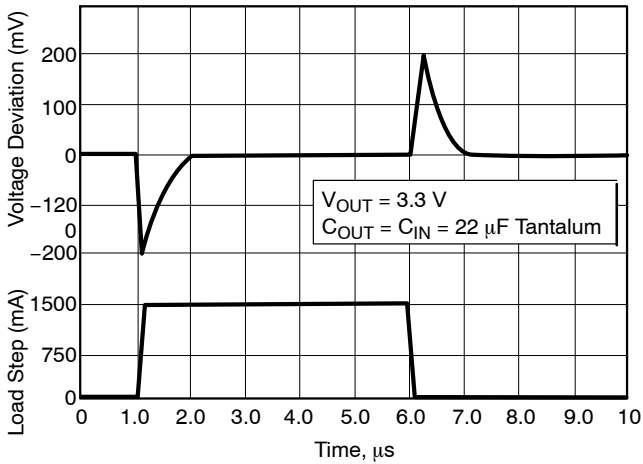

Figure 9. Transient Response (Adjustable Output)

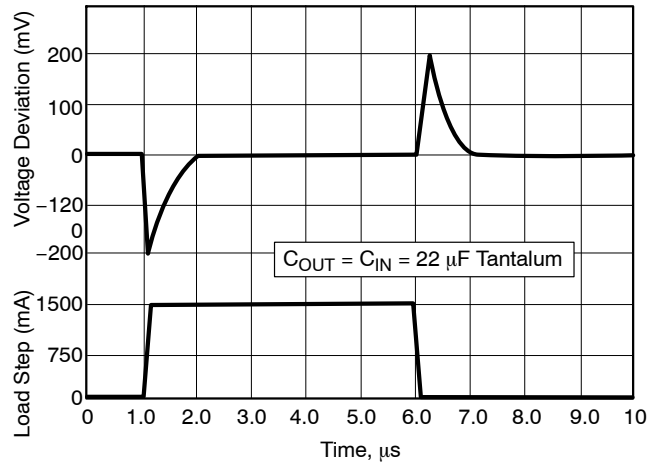

Figure 10. Transient Response (3.3 V Fixed Output)

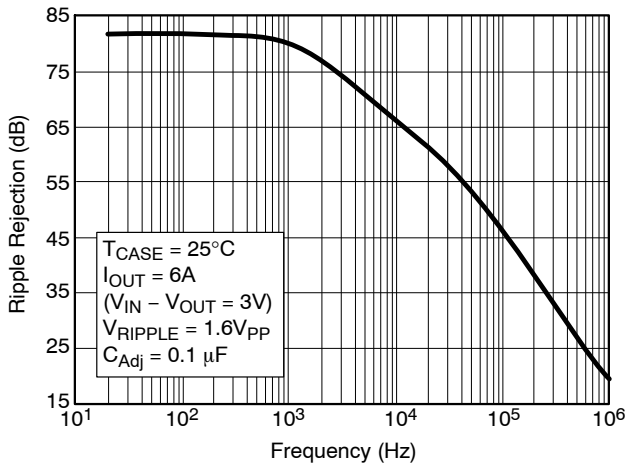

Figure 11. Ripple Rejection vs. Frequency (Adjustable Output)

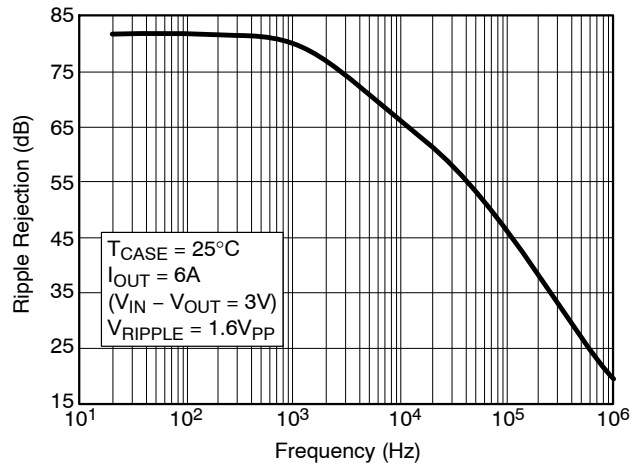

Figure 12. Ripple Rejection vs. Frequency (3.3 V Fixed Output)

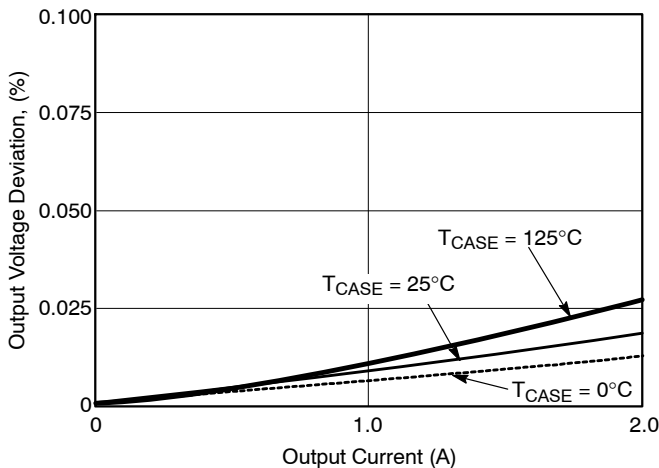

Figure 13. Load Regulation vs. Output Current (Adjustable Output)

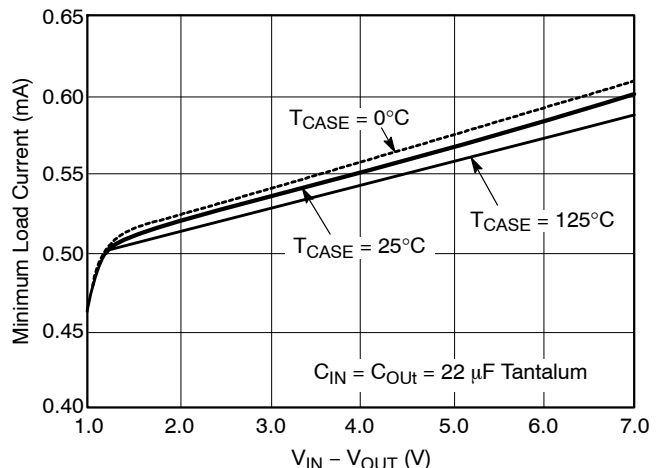

Figure 14. Minimum Load Current vs. $V_{IN} - V_{OUT}$ (Adjustable Output)

APPLICATIONS INFORMATION

The NCP1086 voltage regulator series provides adjustable and 3.3 V output voltages at currents up to 1.5 A. The regulator is protected against overcurrent conditions and includes thermal shutdown.

The NCP1086 series has a composite PNP–NPN output transistor and requires an output capacitor for stability. A detailed procedure for selecting this capacitor is included in the Stability Considerations section.

Adjustable Operation

The adjustable output device has an output voltage range of 1.25 V to 5.5 V. An external resistor divider sets the output voltage as shown in Figure 15. The regulator maintains a fixed 1.25 V (typical) reference between the output pin and the adjust pin.

A resistor divider network R1 and R2 causes a fixed current to flow to ground. This current creates a voltage across R2 that adds to the 1.25 V across R1 and sets the overall output voltage. The adjust pin current (typically 50 μ A) also flows through R2 and adds a small error that should be taken into account if precise adjustment of V_{OUT} is necessary.

The output voltage is set according to the formula:

$$V_{OUT} = V_{REF} \times \left(\frac{R1 + R2}{R1} \right) + I_{Adj} \times R2$$

The term $I_{Adj} \times R2$ represents the error added by the adjust pin current.

R1 is chosen so that the minimum load current is at least 2.0 mA. R1 and R2 should be the same type, e.g. metal film for best tracking over temperature.

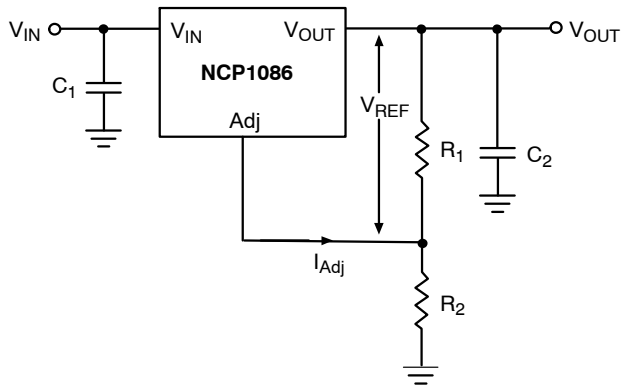

Figure 15. Resistor Divider Scheme

The adjustable output linear regulator has an absolute maximum specification of 7.0 V for the voltage difference between V_{IN} and V_{OUT}. However, the IC may be used to regulate voltages in excess of 7.0 V. The main considerations in such a design are powerup and short circuit capability.

In most applications, ramp-up of the power supply to V_{IN} is fairly slow, typically on the order of several tens of milliseconds, while the regulator responds in less than one microsecond. In this case, the linear regulator begins charging the load as soon as the V_{IN} to V_{OUT} differential is large enough that the pass transistor conducts current. The load at this point is essentially at ground, and the supply voltage is on the order of several hundred mV, with the result that the pass transistor is in dropout. As the supply to V_{IN} increases, the pass transistor will remain in dropout, and current is passed to the load until V_{OUT} reaches the point at which the IC is in regulation. Further increase in the supply voltage brings the pass transistor out of dropout. The result is that the output voltage follows the power supply ramp-up, staying in dropout until the regulation point is reached. In this manner, any output voltage may be regulated. There is no theoretical limit to the regulated voltage as long as the V_{IN} to V_{OUT} differential of 7.0 V is not exceeded.

However, the possibility of destroying the IC in a short circuit condition is very real for this type of design. Short circuit conditions will result in the immediate operation of the pass transistor outside of its safe operating area. Overvoltage stresses will then cause destruction of the pass transistor before overcurrent or thermal shutdown circuitry can become active. Additional circuitry may be required to clamp the V_{IN} to V_{OUT} differential to less than 7.0 V if fail-safe operation is required. One possible clamp circuit is illustrated in Figure 16; however, the design of clamp circuitry must be done on an application by application basis. Care must be taken to ensure the clamp actually protects the design. Components used in the clamp design

must be able to withstand the short circuit condition indefinitely while protecting the IC.

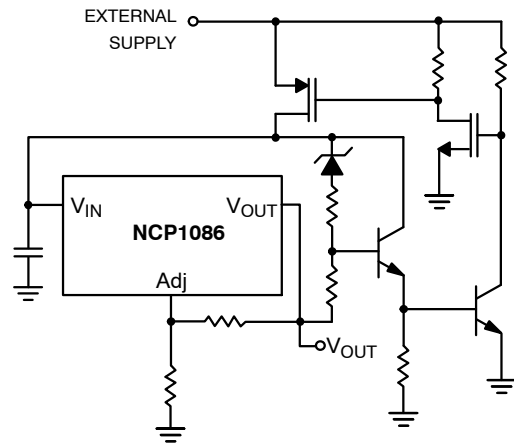

Figure 16. Short Circuit Protection Circuit for High Voltage Application

Stability Considerations

The output or compensation capacitor helps determine three main characteristics of a linear regulator: startup delay, load transient response and loop stability.

The capacitor value and type is based on cost, availability, size and temperature constraints. A tantalum or aluminum electrolytic capacitor is best, since a film or ceramic capacitor with almost zero ESR can cause instability. The aluminum electrolytic capacitor is the least expensive solution. However, when the circuit operates at low temperatures, both the value and ESR of the capacitor will vary considerably. The capacitor manufacturers' data sheet provides this information.

A 22 μF tantalum capacitor will work for most applications, but with high current regulators such as the NCP1086 series the transient response and stability improve with higher values of capacitance. The majority of applications for this regulator involve large changes in load current, so the output capacitor must supply the instantaneous load current. The ESR of the output capacitor causes an immediate drop in output voltage given by:

$$\Delta V = \Delta I \times ESR$$

For microprocessor applications it is customary to use an output capacitor network consisting of several tantalum and ceramic capacitors in parallel. This reduces the overall ESR and reduces the instantaneous output voltage drop under load transient conditions. The output capacitor network should be as close as possible to the load for the best results.

NCP1086

Protection Diodes

When large external capacitors are used with a linear regulator it is sometimes necessary to add protection diodes. If the input voltage of the regulator gets shorted, the output capacitor will discharge into the output of the regulator. The discharge current depends on the value of the capacitor, the output voltage and the rate at which V_{IN} drops. In the NCP1086 series linear regulator, the discharge path is through a large junction and protection diodes are not usually needed. If the regulator is used with large values of output capacitance and the input voltage is instantaneously shorted to ground, damage can occur. In this case, a diode connected as shown in Figure 17 or Figure 18 is recommended.

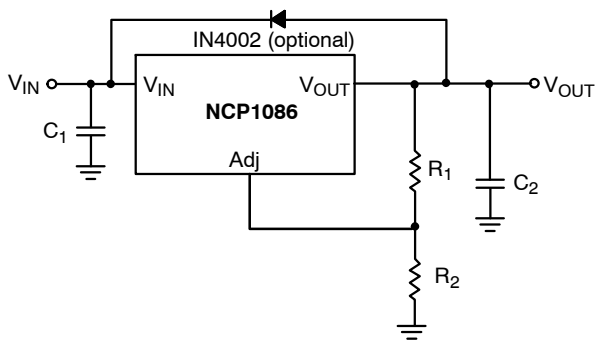

Figure 17. Protection Diode Scheme for Large Output Capacitors (Adjustable Output)

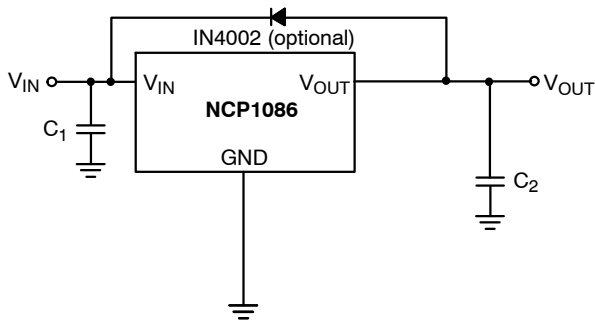

Figure 18. Protection Diode Scheme for Large Output Capacitors (3.3 V Fixed Output)

Output Voltage Sensing

Since the NCP1086 is a three terminal regulator, it is not possible to provide true remote load sensing. Load regulation is limited by the resistance of the conductors connecting the regulator to the load.

For best results the fixed output regulator should be connected as shown in Figure 19.

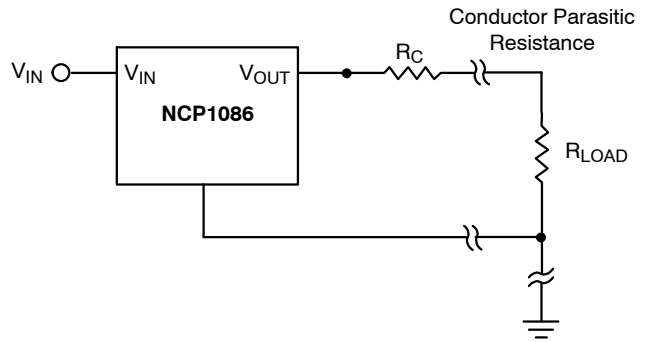

Figure 19. Conductor Parasitic Resistance Effects Can Be Minimized with the Above Grounding Scheme for Fixed Output Regulators

For the adjustable regulator, the best load regulation occurs when R1 is connected directly to the output pin of the regulator as shown in Figure 20. If R1 is connected to the load, R_C is multiplied by the divider ratio and the effective resistance between the regulator and the load becomes

$$R_C \times \left(\frac{R_1 + R_2}{R_1} \right)$$

where R_C = conductor parasitic resistance.

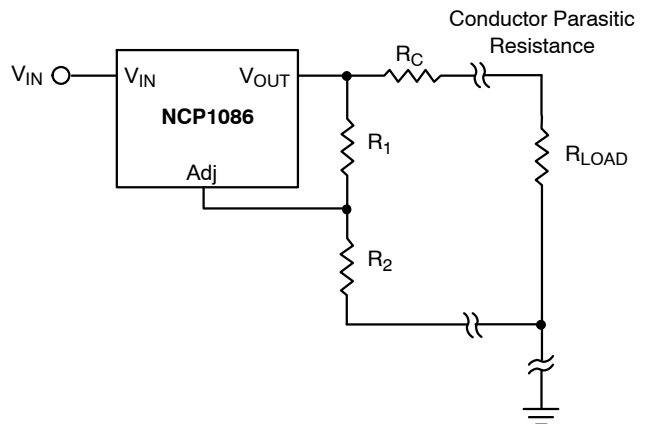

Figure 20. Grounding Scheme for the Adjustable Output Regulator to Minimize Parasitic Resistance Effects

Calculating Power Dissipation and Heatsink Requirements

The NCP1086 linear regulator includes thermal shutdown and current limit circuitry to protect the device. High power regulators such as these usually operate at high junction temperatures so it is important to calculate the power dissipation and junction temperatures accurately to ensure that an adequate heatsink is used.

The case is connected to V_{OUT} , and electrical isolation may be required for some applications. Thermal compound should always be used with high current regulators such as these.

The thermal characteristics of an IC depend on the following four factors:

1. Maximum Ambient Temperature T_A ($^{\circ}C$)
2. Power dissipation P_D (W)
3. Maximum junction temperature T_J ($^{\circ}C$)
4. Thermal resistance junction to ambient $R_{\theta JA}$ ($^{\circ}C/W$)

These four are related by the equation

$$T_J = T_A + P_D \times R_{\theta JA} \quad (\text{eq. 1})$$

The maximum ambient temperature and the power dissipation are determined by the design while the maximum junction temperature and the thermal resistance depend on the manufacturer and the package type.

The maximum power dissipation for a regulator is:

$$P_{D(\max)} = \{V_{IN(\max)} - V_{OUT(\min)}\}I_{OUT(\max)} + V_{IN(\max)}I_Q \quad (\text{eq. 2})$$

where:

$V_{IN(\max)}$ is the maximum input voltage,

$V_{OUT(\min)}$ is the minimum output voltage,

$I_{OUT(\max)}$ is the maximum output current, for the application

I_Q is the maximum quiescent current at $I_{OUT(\max)}$.

A heatsink effectively increases the surface area of the package to improve the flow of heat away from the IC and into the surrounding air.

Each material in the heat flow path between the IC and the outside environment has a thermal resistance. Like series electrical resistances, these resistances are summed to determine $R_{\theta JA}$, the total thermal resistance between the junction and the surrounding air.

1. Thermal Resistance of the junction to case, $R_{\theta JC}$ ($^{\circ}C/W$)
2. Thermal Resistance of the case to Heatsink, $R_{\theta CS}$ ($^{\circ}C/W$)
3. Thermal Resistance of the Heatsink to the ambient air, $R_{\theta SA}$ ($^{\circ}C/W$)

These are connected by the equation:

$$R_{\theta JA} = R_{\theta JC} + R_{\theta CS} + R_{\theta SA} \quad (\text{eq. 3})$$

The value for $R_{\theta JA}$ is calculated using Equation 3 and the result can be substituted in Equation 1.

The value for $R_{\theta JC}$ is $3.5^{\circ}C/W$. For a high current regulator such as the NCP1086 the majority of the heat is generated in the power transistor section. The value for $R_{\theta SA}$ depends on the heatsink type, while $R_{\theta CS}$ depends on factors such as package type, heatsink interface (is an insulator and thermal grease used?), and the contact area between the heatsink and the package. Once these calculations are complete, the maximum permissible value of $R_{\theta JA}$ can be calculated and the proper heatsink selected. For further discussion on heatsink selection, see application note "Thermal Management," document number AND8036/D via our website at www.onsemi.com.

NCP1086

ORDERING INFORMATION

Device	Type	Package	Shipping†
NCP1086D2T-ADJ	Adjustable	D ² PAK	50 Units/Rail
NCP1086D2T-ADJG		D ² PAK (Pb-Free)	50 Units/Rail
NCP1086D2T-ADJR4		D ² PAK	750 Tape & Reel
NCP1086D2TADJR4G		D ² PAK (Pb-Free)	
NCP1086ST-ADJT3		SOT-223	2500 Tape & Reel
NCP1086ST-ADJT3G		SOT-223 (Pb-Free)	
NCP1086T-ADJ		TO220	50 Units/Rail
NCP1086T-ADJG		TO220 (Pb-Free)	
NCP1086D2T-033	3.3 V	D ² PAK	50 Units/Rail
NCP1086D2T-33R4		D ² PAK	750 Tape & Reel
NCP1086D2T-33R4G		D ² PAK (Pb-Free)	
NCP1086ST-33T3		SOT-223	2500 Tape & Reel
NCP1086ST-33T3G		SOT-223 (Pb-Free)	
NCP1086T-033		TO220	50 Units/Rail
NCP1086T-033G		TO220 (Pb-Free)	

†For information on tape and reel specifications, including part orientation and tape sizes, please refer to our Tape and Reel Packaging Specifications Brochure, BRD8011/D.

NCP1086

MARKING DIAGRAMS

Adjustable Output

TO-220-3
T SUFFIX
CASE 221A

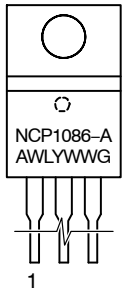

D²PAK-3
D2T SUFFIX
CASE 418AB

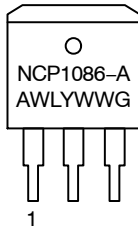

SOT-223
ST SUFFIX
CASE 318E

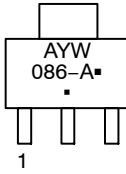

3.3 V Fixed Output

TO-220-3
T SUFFIX
CASE 221A

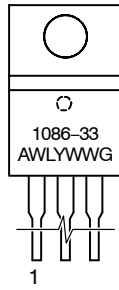

D²PAK-3
D2T SUFFIX
CASE 418AB

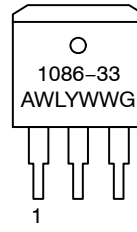

SOT-223
ST SUFFIX
CASE 318E

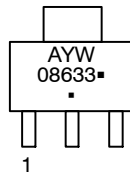

A = Assembly Location
WL, L = Wafer Lot
YY, Y = Year
WW, W = Work Week
G or ■ = Pb-Free Package

NCP1086

PACKAGE DIMENSIONS

TO-220 3-LEAD
T SUFFIX
CASE 221AF-01
ISSUE A

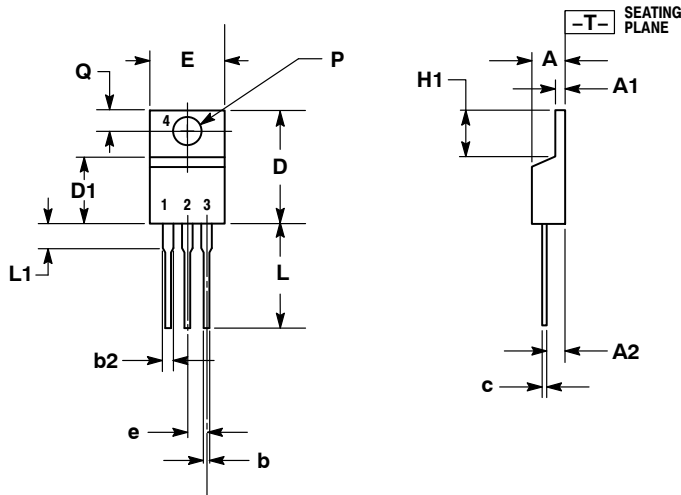

NOTES:

1. DIMENSIONING AND TOLERANCING PER ASME Y14.5M, 1994.
2. CONTROLLING DIMENSION: INCHES.
3. DIMENSIONS D AND E DO NOT INCLUDE MOLD FLASH AND GATE PROTRUSIONS. MOLD FLASH AND GATE PROTRUSIONS NOT TO EXCEED 0.005 PER SIDE. THESE DIMENSIONS ARE TO BE MEASURED AT OUTERMOST EXTREME OF THE PLASTIC BODY.
3. DIMENSION b2 DOES NOT INCLUDE DAMBAR PROTRUSION. LEAD WIDTH INCLUDING PROTRUSION SHALL NOT EXCEED 0.080.

DIM	INCHES		MILLIMETERS	
	MIN	MAX	MIN	MAX
A	0.140	0.190	3.56	4.83
A1	0.045	0.055	1.14	1.40
A2	0.080	0.115	2.03	2.92
b	0.025	0.040	0.64	1.02
b2	0.045	0.070	1.14	1.78
c	0.014	0.025	0.36	0.64
D	0.560	0.625	14.22	15.88
D1	0.320	0.390	8.13	9.91
E	0.380	0.420	9.65	10.67
e	0.100 BSC		2.54 BSC	
H1	0.235	0.255	5.97	6.48
L	0.500	0.580	12.70	14.73
L1	---	0.280	---	7.11
P	0.139	0.161	3.53	4.09
Q	0.100	0.135	2.54	3.43

NCP1086

PACKAGE DIMENSIONS

D²PAK-3 CASE 418AB-01 ISSUE A

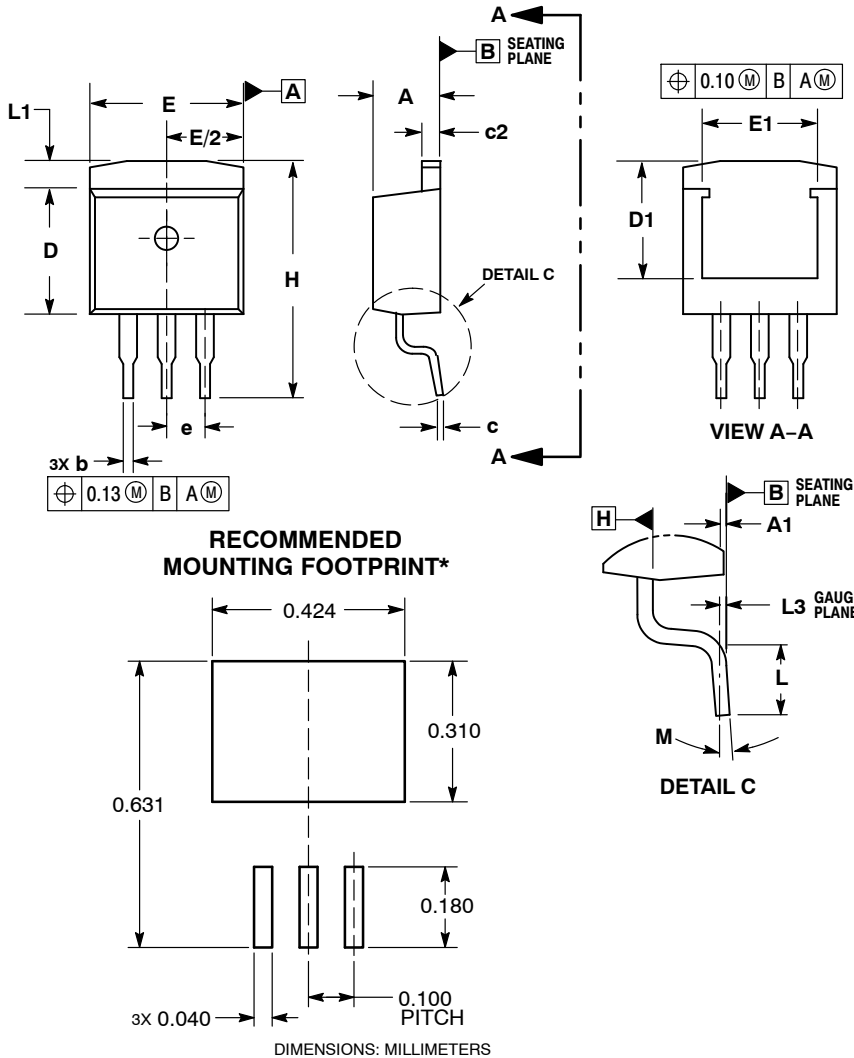

NOTES:

1. DIMENSIONING AND TOLERANCING PER ASME Y14.5M, 1994.
2. CONTROLLING DIMENSION: INCHES.
3. DIMENSIONS D AND E DO NOT INCLUDE MOLD FLASH AND GATE PROTRUSIONS. MOLD FLASH AND GATE PROTRUSIONS NOT TO EXCEED 0.005 MAXIMUM PER SIDE. THESE DIMENSIONS TO BE MEASURED AT DATUM H.
4. THERMAL PAD CONTOUR OPTIONAL WITHIN DIMENSIONS E, L1, D1, AND E1. DIMENSIONS D1 AND E1 ESTABLISH A MINIMUM MOUNTING SURFACE FOR THE THERMAL PAD.

DIM	INCHES		MILLIMETERS	
	MIN	MAX	MIN	MAX
A	0.170	0.180	4.32	4.57
A1	0.000	0.010	0.00	0.25
b	0.026	0.036	0.66	0.91
c	0.017	0.026	0.43	0.66
c2	0.045	0.055	1.14	1.40
D	0.325	0.368	8.25	9.53
D1	0.270	---	6.86	---
E	0.380	0.420	9.65	10.67
E1	0.245	---	6.22	---
e	0.100 BSC		2.54 BSC	
H	0.580	0.620	14.73	15.75
L	0.090	0.110	2.29	2.79
L1	---	0.066	---	1.68
L3	0.010 BSC		0.25 BSC	
M	0°	8°	0°	8°

*For additional information on our Pb-Free strategy and soldering details, please download the ON Semiconductor Soldering and Mounting Techniques Reference Manual, SOLDERRM/D.

PACKAGE THERMAL DATA

Parameter		TO-220-3	D ² PAK-3	SOT-223	Unit
R _{θJC}	Typical	3.5	3.5	15	°C/W
R _{θJA}	Typical	50	10-50*	156	°C/W

* Depending on thermal properties of substrate. $R_{\theta JA} = R_{\theta JC} + R_{\theta CA}$

NCP1086

PACKAGE DIMENSIONS

SOT-223 (TO-261)
ST SUFFIX
CASE 318E-04
ISSUE N

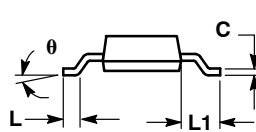
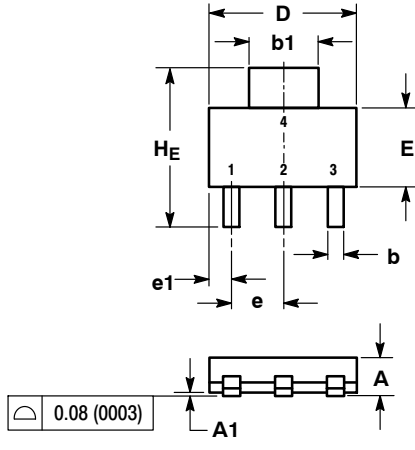

- NOTES:
1. DIMENSIONING AND TOLERANCING PER ASME Y14.5M, 1994.
2. CONTROLLING DIMENSION: INCH.

DIM	MILLIMETERS			INCHES		
	MIN	NOM	MAX	MIN	NOM	MAX
A	1.50	1.63	1.75	0.060	0.064	0.068
A1	0.02	0.06	0.10	0.001	0.002	0.004
b	0.60	0.75	0.89	0.024	0.030	0.035
b1	2.90	3.06	3.20	0.115	0.121	0.126
c	0.24	0.29	0.35	0.009	0.012	0.014
D	6.30	6.50	6.70	0.249	0.256	0.263
E	3.30	3.50	3.70	0.130	0.138	0.145
e	2.20	2.30	2.40	0.087	0.091	0.094
e1	0.85	0.94	1.05	0.033	0.037	0.041
L	0.20	---	---	0.008	---	---
L1	1.50	---	2.00	0.060	0.069	0.078
HE	6.70	7.00	7.30	0.264	0.276	0.287
θ	0°	---	10°	0°	---	10°

SOLDERING FOOTPRINT

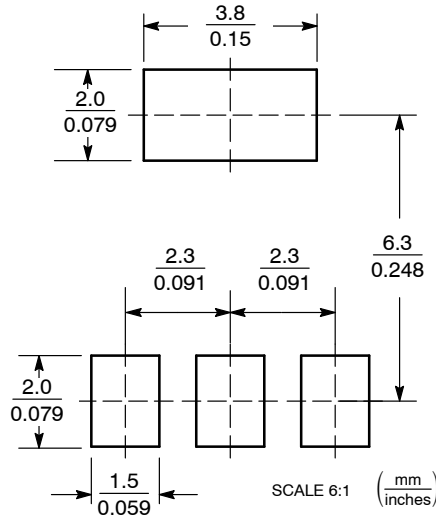

ON Semiconductor and are registered trademarks of Semiconductor Components Industries, LLC (SCILLC). SCILLC reserves the right to make changes without further notice to any products herein. SCILLC makes no warranty, representation or guarantee regarding the suitability of its products for any particular purpose, nor does SCILLC assume any liability arising out of the application or use of any product or circuit, and specifically disclaims any and all liability, including without limitation special, consequential or incidental damages. "Typical" parameters which may be provided in SCILLC data sheets and/or specifications can and do vary in different applications and actual performance may vary over time. All operating parameters, including "Typicals" must be validated for each customer application by customer's technical experts. SCILLC does not convey any license under its patent rights nor the rights of others. SCILLC products are not designed, intended, or authorized for use as components in systems intended for surgical implant into the body, or other applications intended to support or sustain life, or for any other application in which the failure of the SCILLC product could create a situation where personal injury or death may occur. Should Buyer purchase or use SCILLC products for any such unintended or unauthorized application, Buyer shall indemnify and hold SCILLC and its officers, employees, subsidiaries, affiliates, and distributors harmless against all claims, costs, damages, and expenses, and reasonable attorney fees arising out of, directly or indirectly, any claim of personal injury or death associated with such unintended or unauthorized use, even if such claim alleges that SCILLC was negligent regarding the design or manufacture of the part. SCILLC is an Equal Opportunity/Affirmative Action Employer. This literature is subject to all applicable copyright laws and is not for resale in any manner.

PUBLICATION ORDERING INFORMATION

LITERATURE FULFILLMENT:
Literature Distribution Center for ON Semiconductor
P.O. Box 5163, Denver, Colorado 80217 USA
Phone: 303-675-2175 or 800-344-3860 Toll Free USA/Canada
Fax: 303-675-2176 or 800-344-3867 Toll Free USA/Canada
Email: orderlit@onsemi.com

N. American Technical Support: 800-282-9855 Toll Free
USA/Canada
Europe, Middle East and Africa Technical Support:
Phone: 421 33 790 2910
Japan Customer Focus Center
Phone: 81-3-5773-3850

ON Semiconductor Website: www.onsemi.com

Order Literature: <http://www.onsemi.com/orderlit>

For additional information, please contact your local Sales Representative

Looking for pricing, stock, or lifecycle information?

Click below to explore more details on WIN SOURCE:

- ⊖ [View NCP1086T-ADJG on WIN SOURCE](#)
- ⊖ [ON Semiconductor Information](#)

Optimize Your Supply Chain with WIN SOURCE Solutions

- ✓ Global Sourcing Solution
- ✓ Obsolete Management
- ✓ Cost Control Management
- ✓ Shortage Management
- ✓ Alternative Solution
- ✓ Excess Inventory Management