

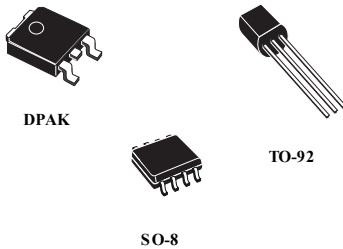

**THE DATASHEET OF
LM2931BDT50**



Very low drop voltage regulators with inhibit function



Features

- AEC-Q100 qualified (DPAK only)
- Very low dropout voltage (90 mV typ. at 10 mA load)
- Low quiescent current (typ. 2.5 mA, at 100 mA load)
- Output current up to 100 mA
- Adjustable (from $V_{OUT} = 2.5$ V only SO-8) and fixed (3.3 V and 5 V) output voltage version
- Internal current and thermal limit
- Load dump protection up to 60 V
- Reverse transient protection up to - 50 V
- Temperature range: - 40 to 125 °C
- Package available: TO-92, DPAK, SO-8 (with inhibit control)

Description

The LM2931 are very low drop regulators. The very low drop voltage and the low quiescent current make them particularly suitable for low noise, low power applications and in battery-powered systems. In the 8-pin configuration (SO-8), fully compatible with the older L78L family, a shutdown logic control function is available. This means that when the device is used as a local regulator it is possible to put a part of the board in standby, decreasing total power consumption. Ideal for automotive applications, LM2931 is protected from reverse battery installations or 2 battery jumps. During the transient, such as a 60 V load dump, when the input voltage can exceed the specified maximum operating input voltage of 26 V, the regulator automatically shuts down to protect both internal circuitry and the load.

Maturity status link

[LM2931](#)

1 Diagram

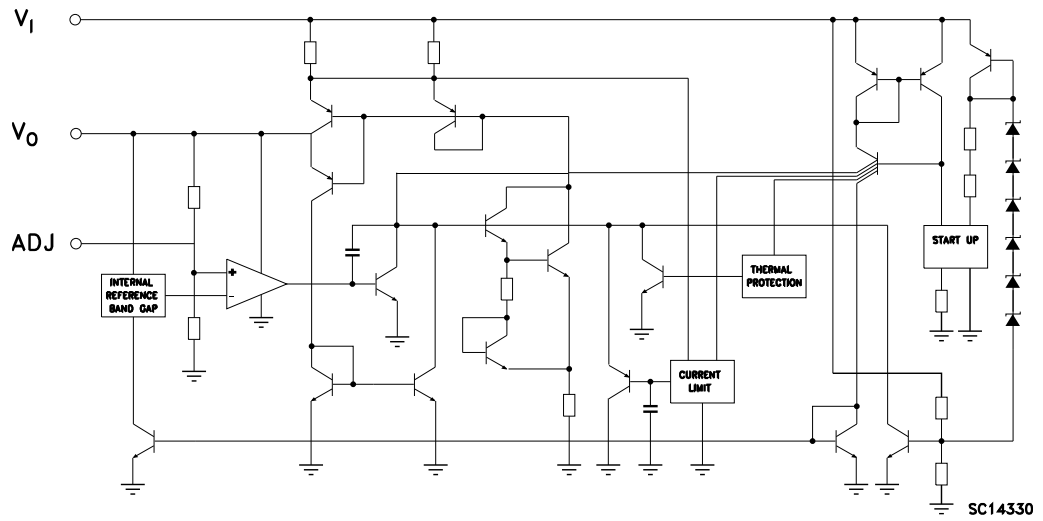
Figure 2. Schematic diagram

AMG110720161100MT

2 Pin configuration

Figure 3. Pin connections (top view)

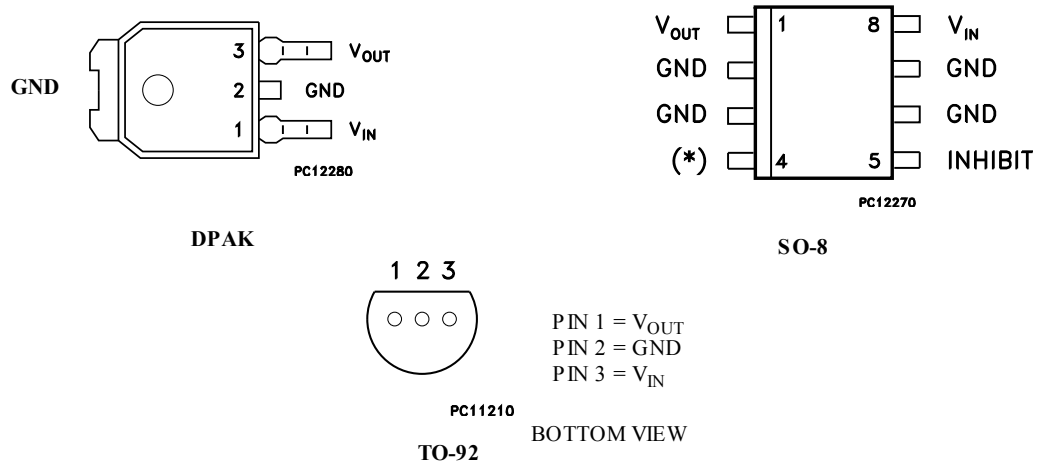

AMG110720161101MT

Note: (*) ADJ pin on the adjustable version, not connected in the fixed output version.

3 Maximum ratings

Table 1. Absolute maximum ratings

Symbol	Parameter	Value	Unit
V_I	DC positive input voltage	40	V
V_I	DC reverse input voltage	-15	V
V_I	Transient input voltage ($T < 100$ ms)	60	V
V_I	Transient reverse input voltage ($T < 100$ ms)	-50	V
V_{INH}	Inhibit input voltage	40	V
I_O	Output current	Internally limited	
T_{STG}	Storage temperature range	-65 to 150	°C
T_{OP}	Operating junction temperature range	-40 to 125	°C

Note: Absolute maximum ratings are those values beyond which damage to the device may occur. Functional operation under these condition is not implied.

Table 2. Thermal data

Symbol	Parameter	SO-8	DPAK	TO-92	Unit
R_{thJC}	Thermal resistance junction-case	20	8	57	°C/W
R_{thJA}	Thermal resistance junction-ambient	55 ⁽¹⁾	100	200	°C/W

1. Considering 6 cm² of copper board heat-sink.

4 Application circuits

Figure 4. Application circuit for fixed output

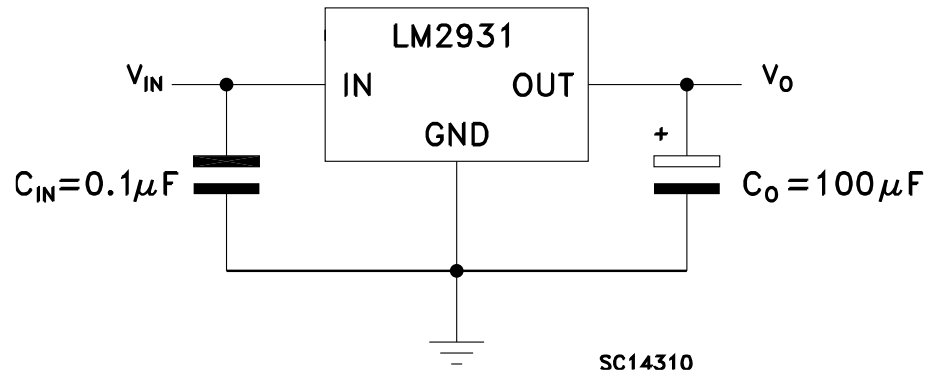

AMG110720161102MT

Figure 5. Application circuit for adjustable output

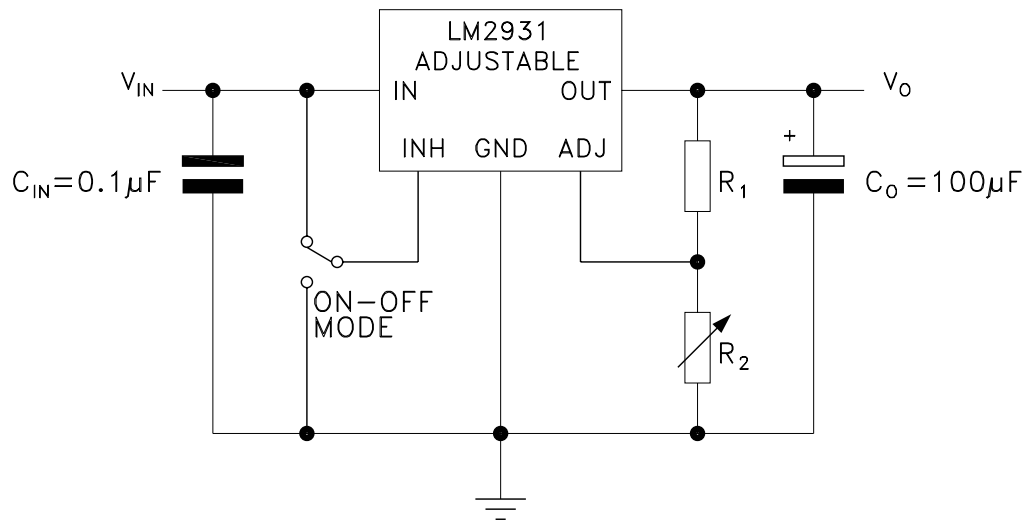

Note: R_1 suggested value = 27 k Ω
 $V_O = V_{REF} (R_1 + R_2)/R_1$
 Inhibit pin: regulator is enabled when $V_{INH} < 1.2$ V , disabled when $V_{INH} > 3.25$ V

5 Electrical characteristics

Refer to the application circuit [Figure 4. Application circuit for fixed output](#), $T_J = 25\text{ °C}$, $C_I = 0.1\text{ }\mu\text{F}$, $C_O = 100\text{ }\mu\text{F}$, $V_I = 14\text{ V}$, $I_O = 10\text{ mA}$, $V_{INH} = 0\text{ V}$, unless otherwise specified.

Table 3. Electrical characteristics of LM2931A33/LM2931A33Y

Symbol	Parameter	Test conditions	Min.	Typ.	Max.	Unit
V_I	Maximum operating input voltage	$I_O = 10\text{ mA}$, $T_J = -40\text{ to }125\text{ °C}$	26			V
V_O	Output voltage		3.175	3.3	3.425	V
V_O	Output voltage	$I_O = 100\text{ mA}$, $V_I = 6\text{ to }26\text{ V}$, $T_J = -40\text{ to }125\text{ °C}$	3.135	3.3	3.465	V
DV_O	Line regulation	$V_I = 9\text{ to }16\text{ V}$		2	10	mV
		$V_I = 6\text{ to }26\text{ V}$		4	33	
DV_O	Load regulation	$I_O = 5\text{ to }100\text{ mA}$		10	33	mV
V_d	Dropout voltage ⁽¹⁾	$I_O = 10\text{ mA}$		90	250	mV
		$I_O = 100\text{ mA}$		250	600	
I_d	Quiescent current ON MODE	$I_O = 100\text{ mA}$		2.5	30	mA
	OFF MODE	$V_{INH} = 2.5\text{ V}$, $R_{LOAD} = 330\text{ }\Omega$		0.3	1	
I_{SC}	Short circuit current		100	300		mA
SVR	Supply voltage rejection	$I_O = 100\text{ mA}$, $V_I = 14 \pm 2\text{ V}$, $f = 120\text{ Hz}$	55	78		dB
V_{IL}	Control input voltage low	$T_J = -40\text{ to }125\text{ °C}$		2	1.2	V
V_{IH}	Control input voltage high	$T_J = -40\text{ to }125\text{ °C}$	3.25	2		V
I_{INH}	Inhibit input current	$V_{INH} = 2.5\text{ V}$		22	50	μA
V_I	Transient input voltage	$R_{LOAD} = 330\text{ }\Omega$, $T < 100\text{ ms}$	60	70		V
V_I	Reverse polarity input voltage	$V_O = \pm 0.3\text{ V}$, $R_{LOAD} = 330\text{ }\Omega$	-15	-50		V
V_I	Reverse polarity input voltage transient	$R_{LOAD} = 330\text{ }\Omega$, $T < 100\text{ ms}$	-50			V
eN	Output noise voltage	$B = 10\text{ Hz to }100\text{ kHz}$		330		μV_{RMS}

1. V_d measured when the output voltage has dropped 100 mV from the nominal value obtained at 14 V.

Refer to the application circuit [Figure 4. Application circuit for fixed output](#), $T_J = 25\text{ °C}$, $C_I = 0.1\text{ }\mu\text{F}$, $C_O = 100\text{ }\mu\text{F}$, $V_I = 14\text{ V}$, $I_O = 10\text{ mA}$, $V_{INH} = 0\text{ V}$, unless otherwise specified.

Table 4. Electrical characteristics of LM2931A50/ LM2931A50Y

Symbol	Parameter	Test conditions	Min.	Typ.	Max.	Unit
V_I	Maximum operating input voltage	$I_O = 10\text{ mA}$, $T_J = -40\text{ to }125\text{ °C}$	26			V
V_O	Output voltage		4.81	5	5.19	V
V_O	Output voltage	$I_O = 100\text{ mA}$, $V_I = 6\text{ to }26\text{ V}$, $T_J = -40\text{ to }125\text{ °C}$	4.75	5	5.25	V
DV_O	Line regulation	$V_I = 9\text{ to }16\text{ V}$		2	10	mV
		$V_I = 6\text{ to }26\text{ V}$		4	30	
DV_O	Load regulation	$I_O = 5\text{ to }100\text{ mA}$		15	50	mV
V_d	Dropout voltage ⁽¹⁾	$I_O = 10\text{ mA}$		90	200	mV
		$I_O = 100\text{ mA}$		250	600	

Symbol	Parameter	Test conditions	Min.	Typ.	Max.	Unit
I_d	Quiescent current ON MODE	$I_O = 100 \text{ mA}$		2.5	30	mA
	OFF MODE	$V_{INH} = 2.5 \text{ V}, R_{LOAD} = 500 \Omega$		0.3	1	mA
I_{SC}	Short circuit current		100	300		mA
SVR	Supply voltage rejection	$I_O = 100 \text{ mA}, V_I = 14 \pm 2 \text{ V } f = 120 \text{ Hz}$	55	75		dB
V_{IL}	Control input voltage low	$T_J = -40 \text{ to } 125 \text{ }^\circ\text{C}$		2	1.2	V
V_{IH}	Control input voltage high	$T_J = -40 \text{ to } 125 \text{ }^\circ\text{C}$	3.25	2		V
I_{INH}	Inhibit input current	$V_{INH} = 2.5 \text{ V}$		22	50	μA
V_I	Transient input voltage	$R_{LOAD} = 500 \Omega, T < 100 \text{ ms}$	60	70		V
V_I	Reverse polarity input voltage	$V_O = \pm 0.3 \text{ V}, R_{LOAD} = 500 \Omega$	-15	-50		V
V_I	Reverse polarity input voltage transient	$R_{LOAD} = 500 \Omega, T < 100 \text{ ms}$	-50			V
eN	Output noise voltage	$B = 10 \text{ Hz to } 100 \text{ kHz}$		500		μV_{RMS}

1. V_d measured when the output voltage has dropped 100 mV from the nominal value obtained at 14 V.

Refer to the application circuit [Figure 5. Application circuit for adjustable output](#) with $R_1 = 27 \text{ k}\Omega$ and $R_2 = 40.5 \text{ k}\Omega$, $T_J = 25 \text{ }^\circ\text{C}$, $C_I = 0.1 \text{ }\mu\text{F}$, $C_O = 100 \text{ }\mu\text{F}$, $V_I = 14 \text{ V}$, $I_O = 10 \text{ mA}$, $V_{INH} = 0 \text{ V}$, unless otherwise specified.

Table 5. Electrical characteristics of LM2931 (adjustable version)

Symbol	Parameter	Test conditions	Min.	Typ.	Max.	Unit
V_I	Maximum operating input voltage	$I_O = 10 \text{ mA}, T_J = -40 \text{ to } 125 \text{ }^\circ\text{C}$	26			V
V_{REF}	Reference voltage ⁽¹⁾		1.14	1.2	1.26	V
V_{REF}	Reference voltage ⁽¹⁾	$I_O = 100 \text{ mA}, T_J = -40 \text{ to } 125 \text{ }^\circ\text{C}$	1.08	1.2	1.32	V
DV_O	Line regulation	$V_I = 3.6 \text{ to } 26 \text{ V}$		0.6	4.5	mV
DV_O	Load regulation	$I_O = 5 \text{ to } 100 \text{ mA}$		9	30	mV
V_d	Dropout voltage ⁽²⁾	$I_O = 10 \text{ mA}$		90	200	mV
		$I_O = 100 \text{ mA}$		250	600	
I_d	Quiescent current ON MODE	$I_O = 100 \text{ mA}$		2.5	30	mA
	OFF MODE	$V_{INH} = 2.5 \text{ V}, R_{LOAD} = 300 \Omega$		0.3	1	mA
I_{SC}	Short circuit current		100	300		mA
SVR	Supply voltage rejection	$I_O = 100 \text{ mA}, V_I = 14 \pm 2 \text{ V } f = 120 \text{ Hz}$	55	80		dB
V_{IL}	Control input voltage low	$T_J = -40 \text{ to } 125 \text{ }^\circ\text{C}$		2	1.2	V
V_{IH}	Control input voltage high	$T_J = -40 \text{ to } 125 \text{ }^\circ\text{C}$	3.25	2		V
I_{INH}	Inhibit input current	$V_{INH} = 2.5 \text{ V}$		22	50	μA
V_I	Transient input voltage	$R_{LOAD} = 300 \Omega, T < 100 \text{ ms}$	60	70		V
V_I	Reverse polarity input voltage	$V_O = \pm 0.3 \text{ V}, R_{LOAD} = 300 \Omega$	-15	-50		V
V_I	Reverse polarity input voltage transient	$R_{LOAD} = 300 \Omega, T < 100 \text{ ms}$	-50			V
eN	Output noise voltage	$B = 10 \text{ Hz to } 100 \text{ kHz}$		330		μV_{RMS}

1. Reference voltage is measured from V_{OUT} to ADJ pin.

2. V_d measured when the output voltage has dropped 100 mV from the nominal value obtained at 14 V.

6 Typical characteristics

Unless otherwise specified $C_I = 0.1 \mu\text{F}$, $C_O = 100 \mu\text{F}$.

Figure 6. Output voltage vs temperature

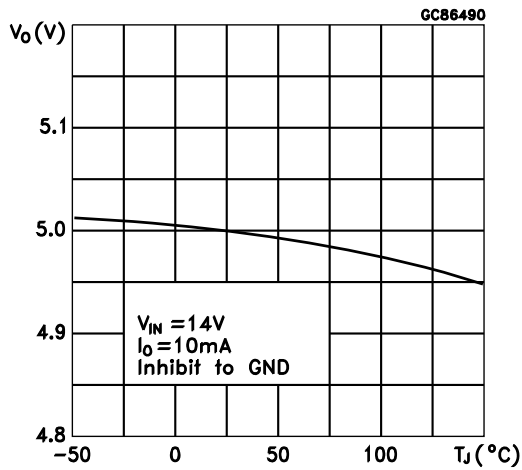

AMG110720161200MT

Figure 7. Output voltage vs temperature

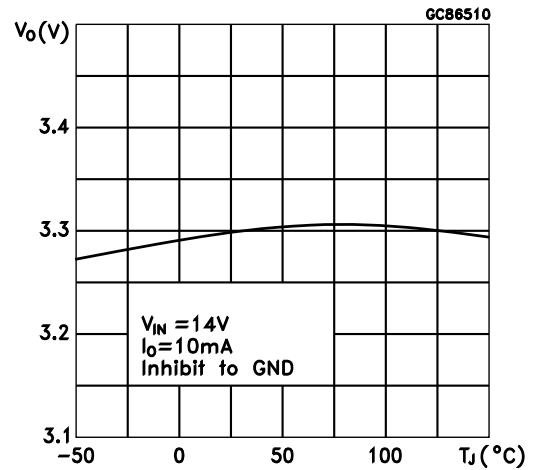

AMG110720161201MT

Figure 8. Reference voltage vs temperature

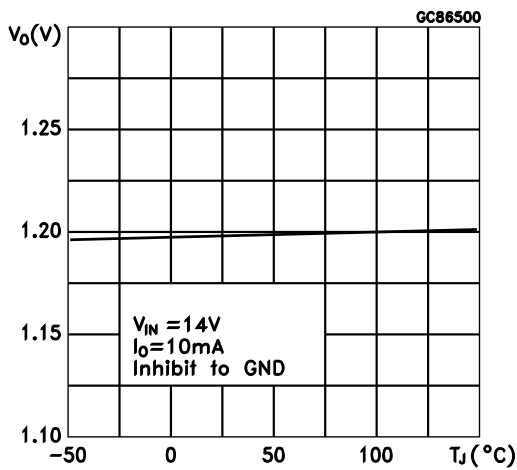

AMG110720161202MT

Figure 9. Line regulation vs temperature

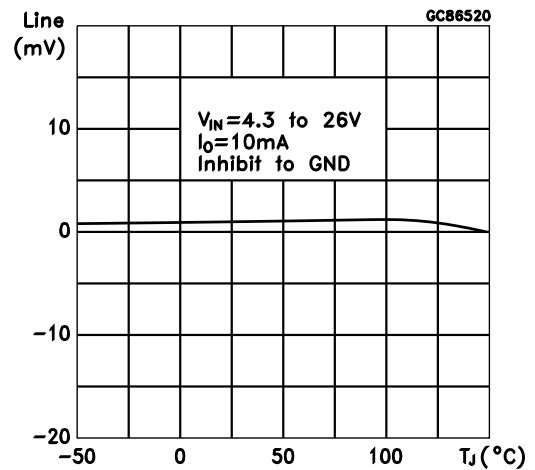

AMG110720161203MT

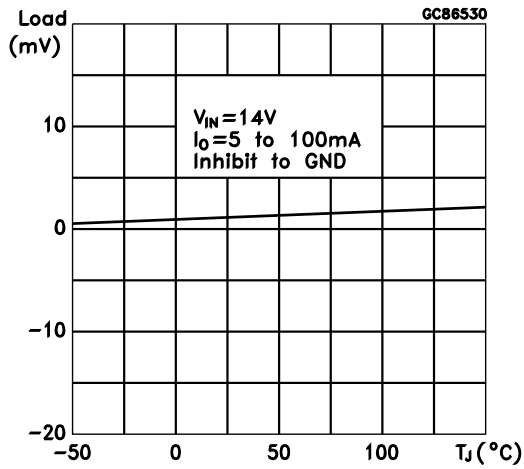
Figure 10. Load regulation vs temperature

AMG110720161204MT

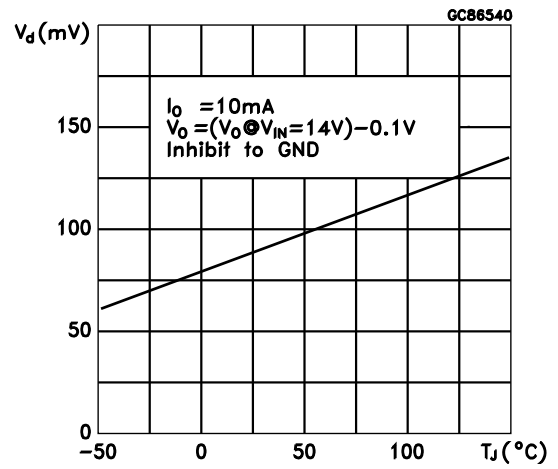
Figure 11. Dropout voltage vs temperature

AMG110720161205MT

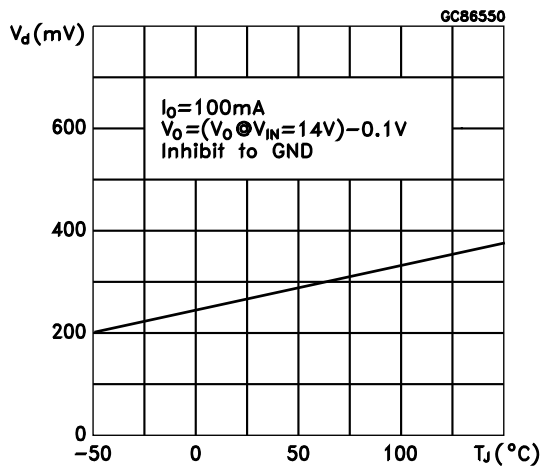
Figure 12. Dropout voltage vs temperature

AMG110720161206MT

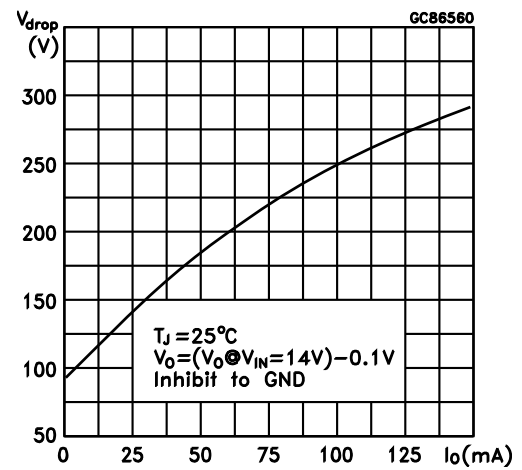
Figure 13. Dropout voltage vs output current

AMG110720161207MT

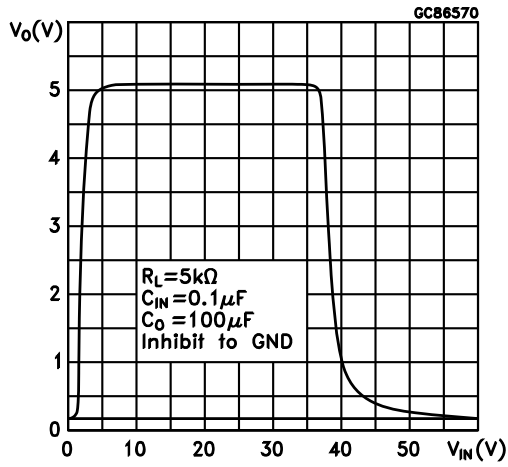
Figure 14. Output voltage vs input voltage

AMG110720161208MT

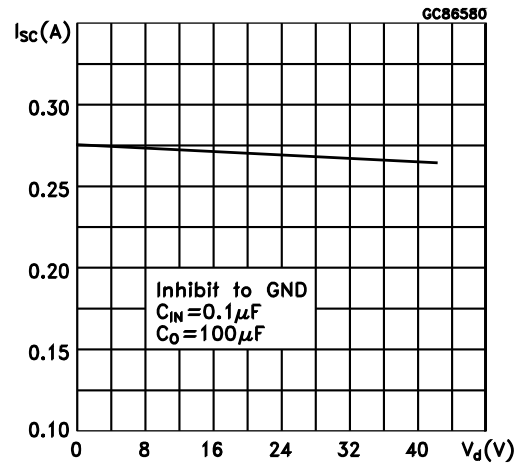
Figure 15. Short circuit current vs drop voltage

AMG110720161209MT

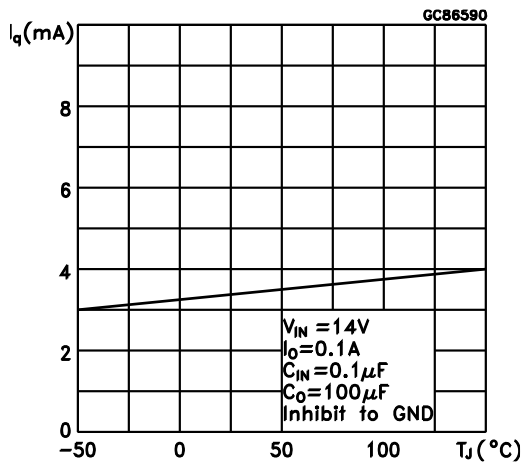
Figure 16. Quiescent current vs temperature

AMG110720161210MT

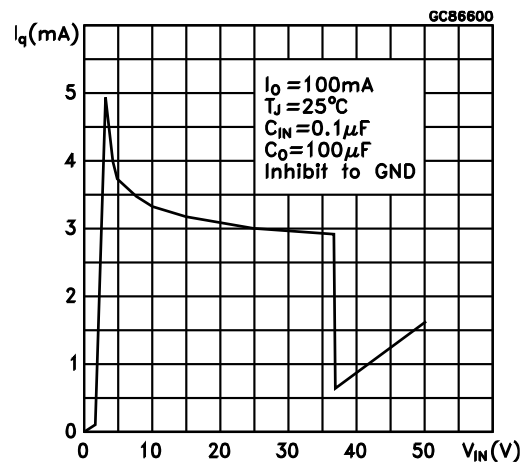
Figure 17. Quiescent current vs input voltage

AMG110720161211MT

Figure 18. Quiescent current vs output current

Figure 19. Supply voltage rejection vs temperature

Figure 20. Supply voltage rejection vs frequency

Figure 21. Supply voltage rejection vs output current

Figure 22. Stability vs CO

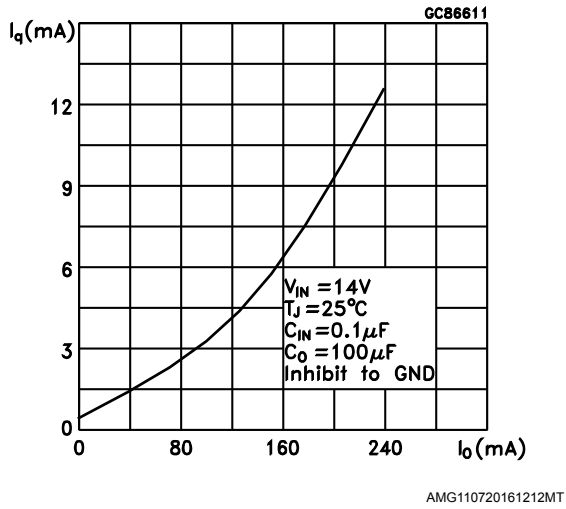
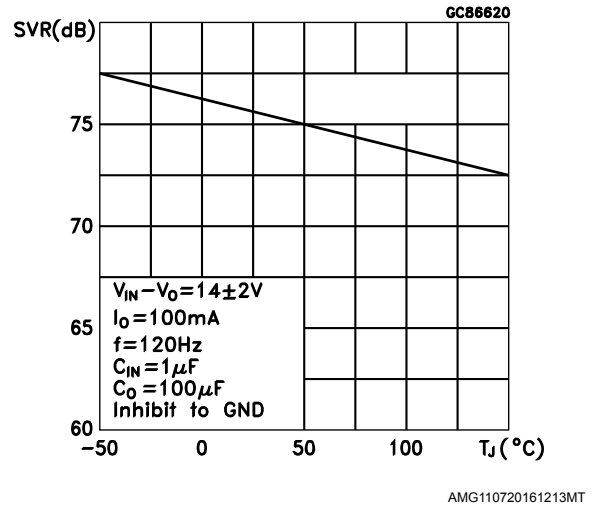
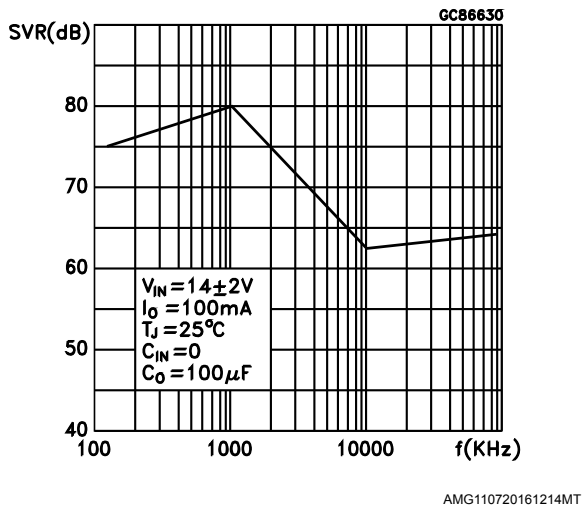
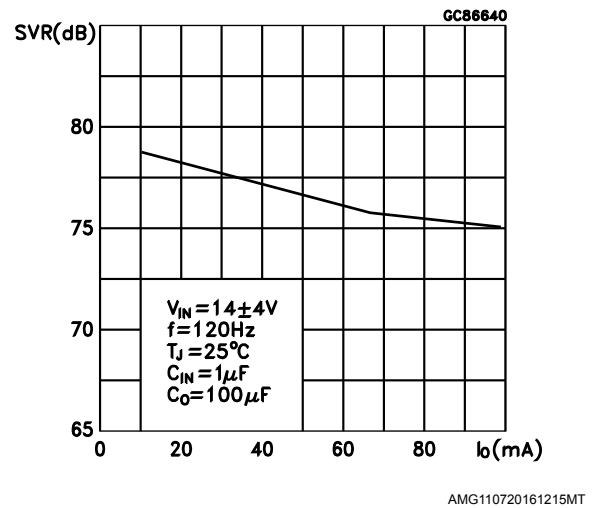
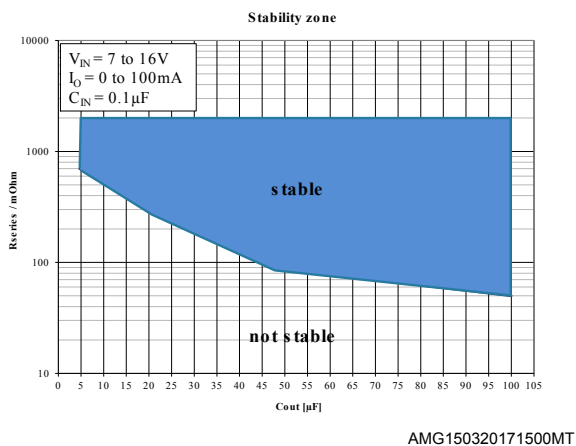
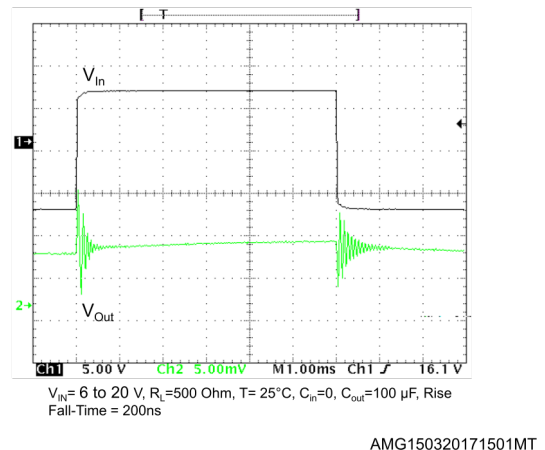
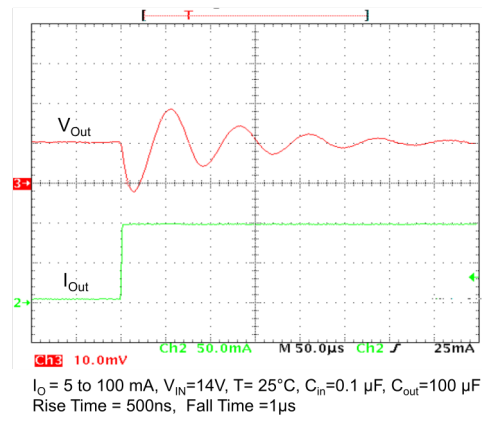
Figure 23. Line transient

Figure 24. Load transient

AMG150320171502MT

7 Package information

In order to meet environmental requirements, ST offers these devices in different grades of ECOPACK® packages, depending on their level of environmental compliance. ECOPACK® specifications, grade definitions and product status are available at: www.st.com. ECOPACK® is an ST trademark.

7.1 DPAK package information

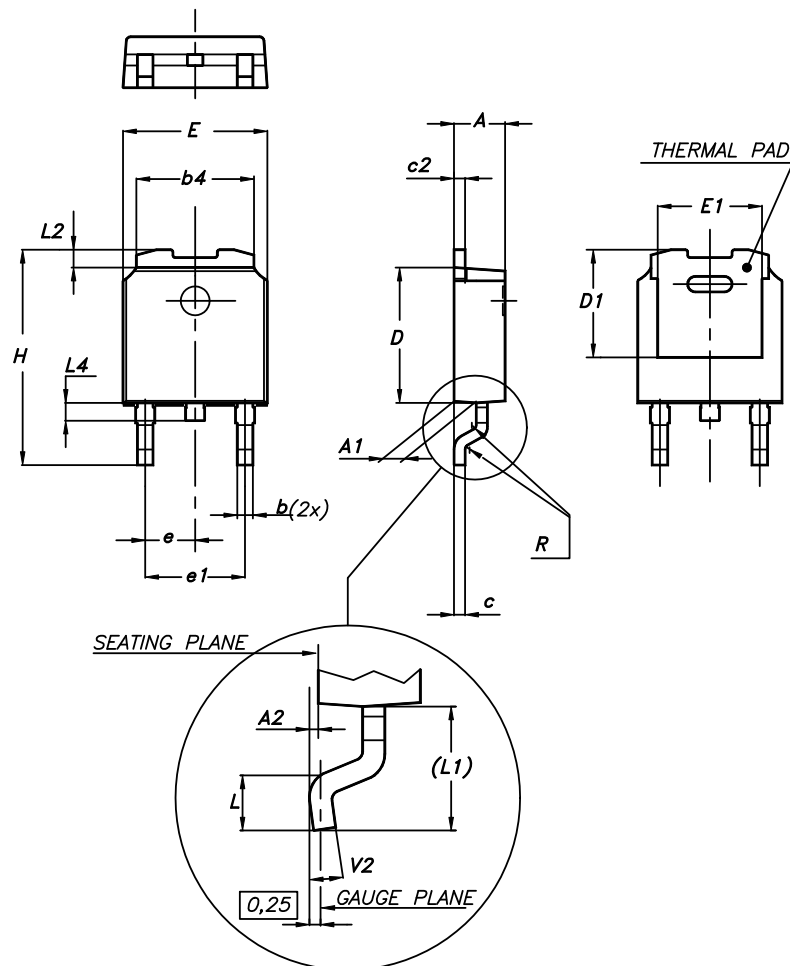
Figure 25. DPAK package outline

0068772_A_21

Table 6. DPAK mechanical data

Dim.	mm		
	Min.	Typ.	Max.
A	2.20		2.40
A1	0.90		1.10
A2	0.03		0.23
b	0.64		0.90
b4	5.20		5.40
c	0.45		0.60
c2	0.48		0.60
D	6.00		6.20

Dim.	mm		
	Min.	Typ.	Max.
D1		5.10	
E	6.40		6.60
E1		4.70	
e		2.28	
e1	4.40		4.60
H	9.35		10.10
L	1.00		1.50
(L1)		2.80	
L2		0.80	
L4	0.60		1.00
R		0.20	
V2	0°		8°

Figure 26. DPAK recommended footprint (dimensions are in mm)

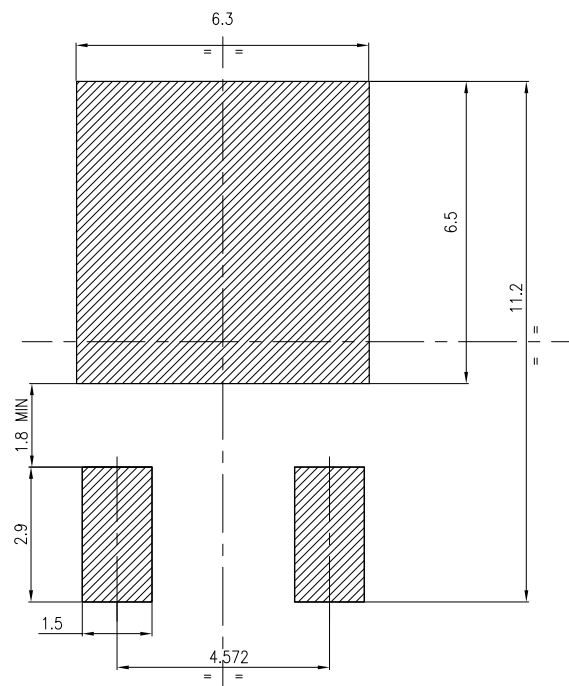

FP_0068772_24

7.2 DPAK packing information

Figure 27. DPAK tape outline

Figure 28. DPAK reel outline



7.3 SO8 package information

Figure 29. SO-8 package outline

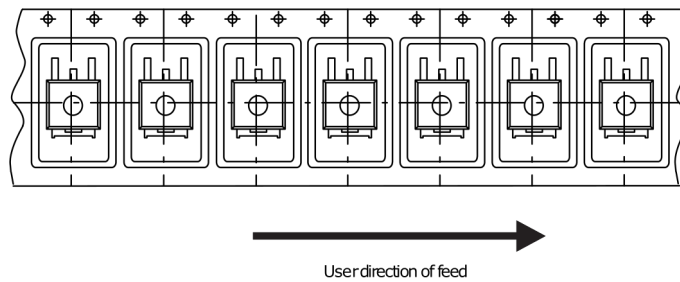
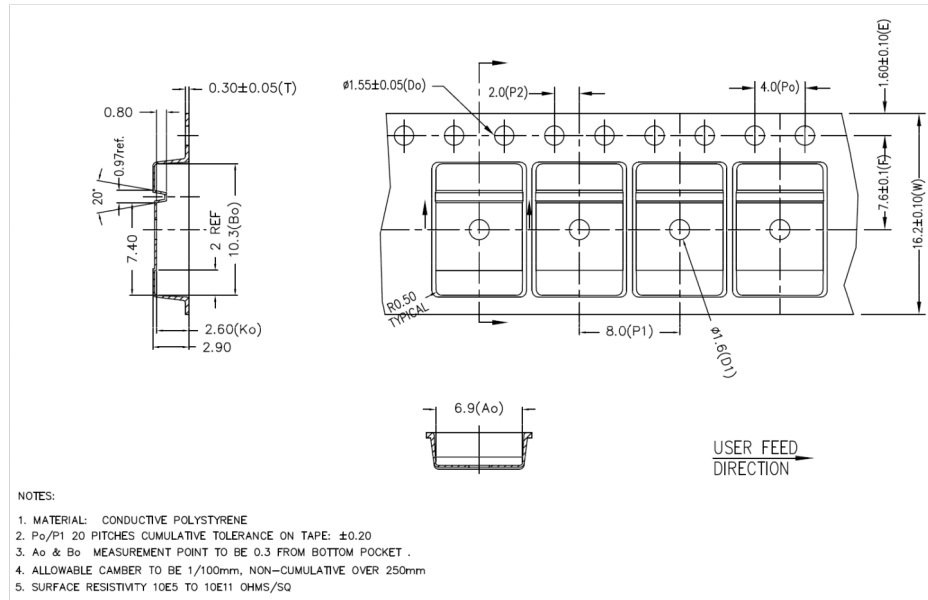
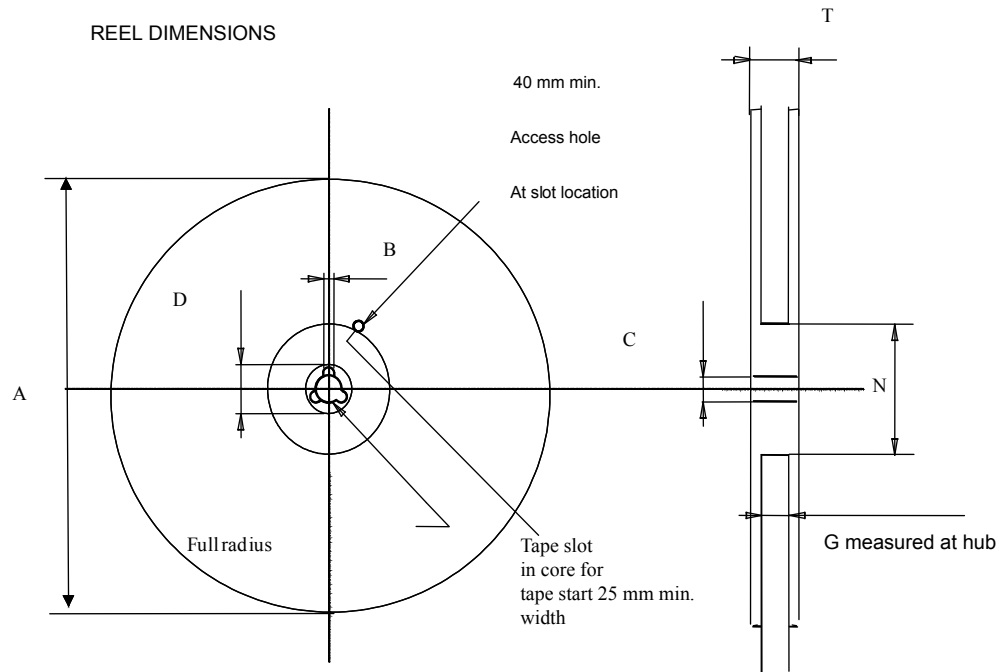
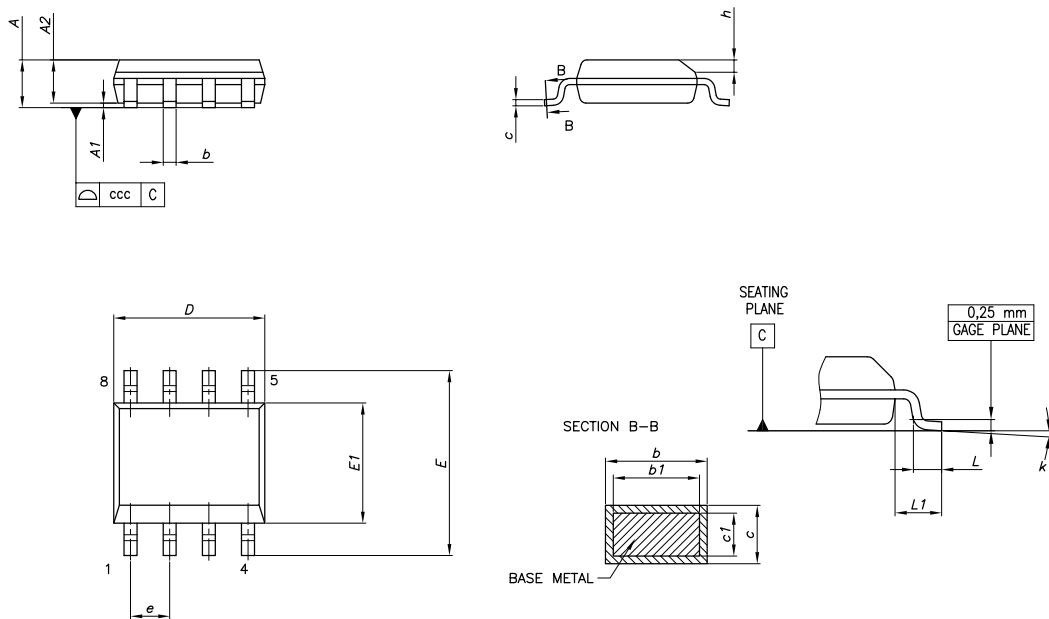

0016023_I

Table 7. SO-8 mechanical data

Dim.	mm		
	Min.	Typ.	Max.
A			1.75
A1	0.10		0.25
A2	1.25		
b	0.28		0.48
c	0.17		0.23
D	4.80	4.90	5.00
E	5.80	6.00	6.20
E1	3.80	3.90	4.00
e		1.27	
h	0.25		0.50
L	0.40		1.27
L1		1.04	
k	0°		8°
ccc			0.10

Figure 30. SO-8 recommended footprint

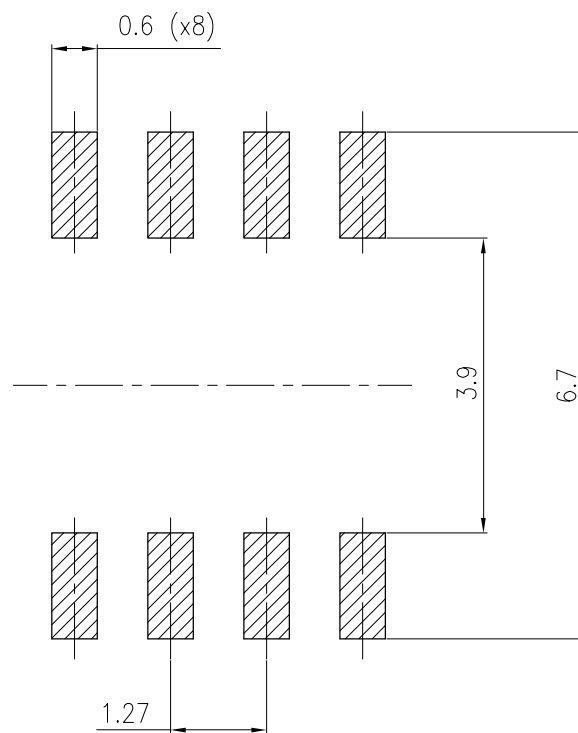

0016023_I

7.4 SO-8 packing information

Figure 31. SO-8 tape and reel outline

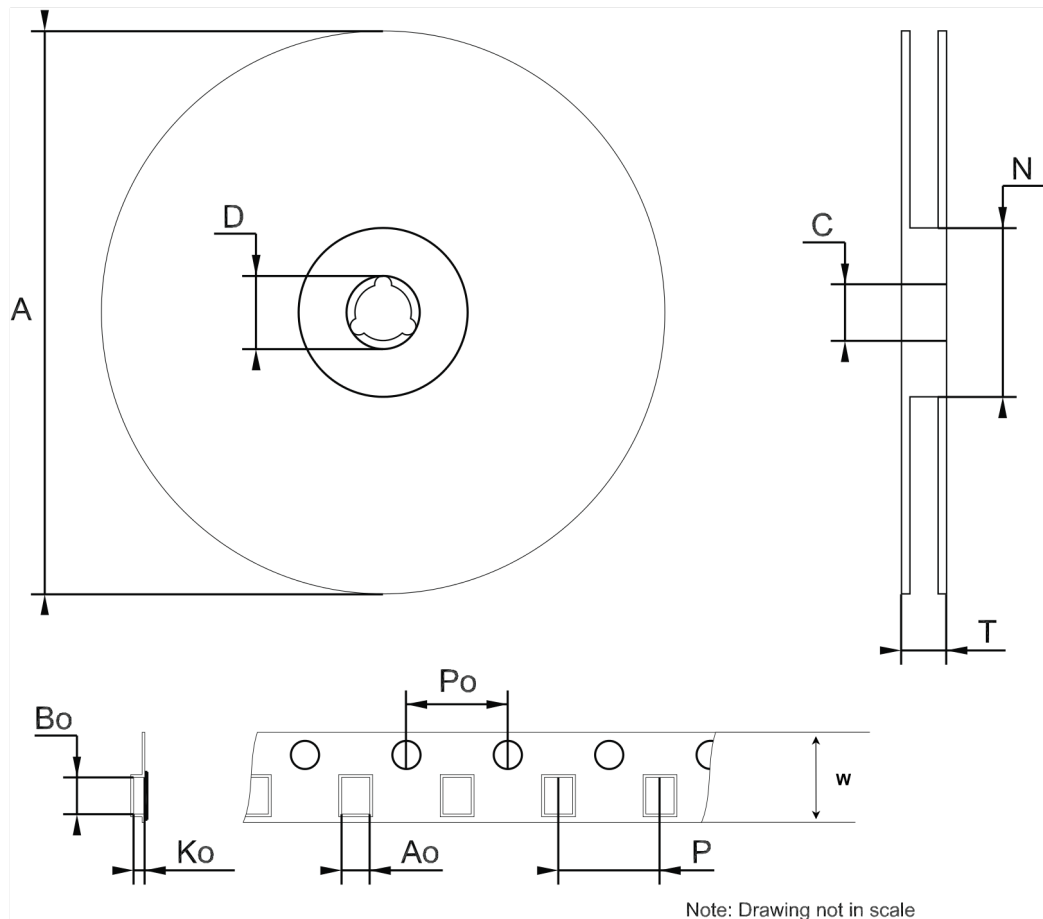
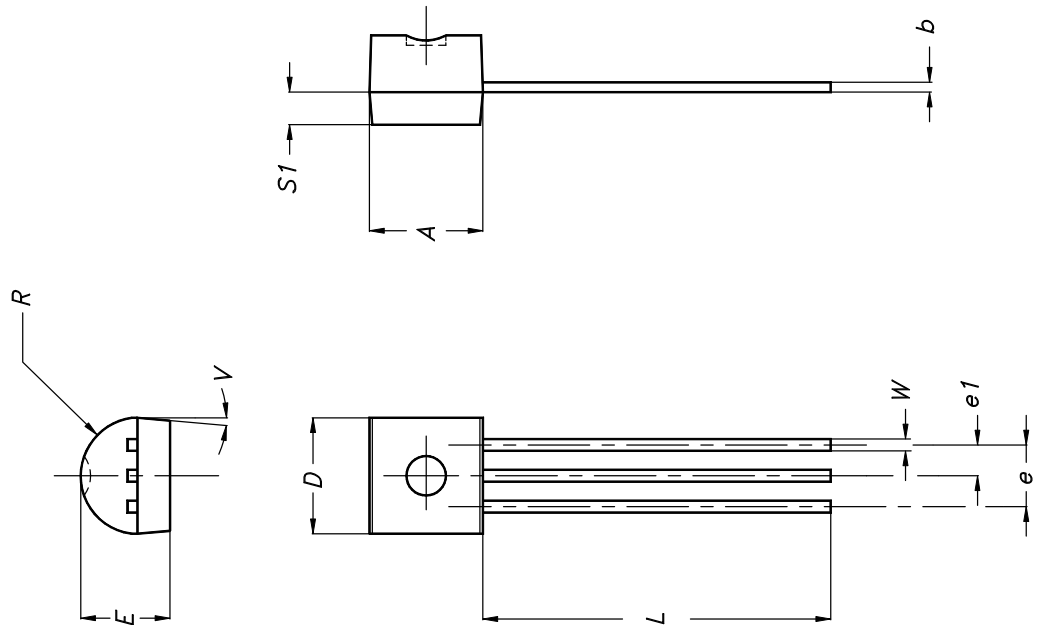

Table 8. SO-8 mechanical data

Dim.	mm		
	Min.	Typ.	Max.
A			330
C	12.8		13.2
D	20.2		
N	50		
T			22.4
Ao	6.4	6.5	6.6
Bo	5.2		5.4
Ko	2.1		2.3
Po	3.9		4.1
P	7.9		8.1
W	11.7	12.0	12.3

7.5 TO-92 package information
Figure 32. TO-92 package outline

0102782_E

Table 9. TO-92 mechanical data

Dim.	mm		
	Min.	Typ.	Max.
A	4.32		4.95
b	0.36		0.51
D	4.45		4.95
E	3.30		3.94
e	2.41		2.67
e1	1.14		1.40
L	12.70		15.49
R	2.16		2.41
S1	0.92		1.52
W	0.41		0.56
V		5°	

8 Ordering informations

Table 10. Order code

DPAK		TO-92 (bag)	SO-8	Output voltages
AG	Standard			
LM2931ADT33RY ⁽¹⁾			LM2931AD33R	3.3 V
LM2931ADT50RY ⁽¹⁾	LM2931ADT50R	LM2931AZ50R	LM2931AD50R	5.0 V
			LM2931D-R	2.5 to 26 V

1. Qualified and characterized according to AEC Q100 and Q003 or equivalent, advanced screening according to AEC Q001 and Q002 or equivalent .

Revision history

Table 11. Document revision history

Date	Revision	Changes
21-Jun-2004	12	Document updated.
16-Jun-2006	13	Order codes updated.
27-Jul-2007	14	Added Table 1 in cover page.
21-Aug-2007	15	Added root part number - (see Table 1).
22-Nov-2007	16	Modified: Table 1.
11-Feb-2008	17	Modified: Table 1 on page 1.
10-Jul-2008	18	Removed package TO-220, modified Table 1 on page 1.
26-May-2010	19	Modified: V_I values Table 4 on page 6, Table 5 on page 7 and Table 6 on page 8.
02-Nov-2011	20	Modified: Figure 4 on page 6. Added: (*) ADJ pin on the Adjustable version, Not Connected in the fixed output version. on page 4 and Inhibit pin: regulator is enabled when $V_{INH} < 1.2 V$, disabled when $V_{INH} > 3.25 V$ on page 6.
09-Apr-2014	21	Part numbers LM2931XX, LM2931AXX33 and LM2931AXX50 changed to LM2931. Updated the description in cover page Section 2: Pin configuration and Section 7: Package information. Added Section 8: Revision history. Minor text changes.
16-Mar-2017	22	Updated features in cover page, removed Table 1. Device summary from cover page, Table 3: "Electrical characteristics of LM2931A33/LM2931A33Y", Table 4: "Electrical characteristics of LM2931A50/ LM2931A50Y" and Table 5: "Electrical characteristics of LM2931 (adjustable version)". Updated Section 7: "Package information". Added Section 8: "Ordering information". Minor text changes.
23-Feb-2018	23	Updated Figure 5. Application circuit for adjustable output .

Contents

1	Diagram	2
2	Pin configuration	3
3	Maximum ratings	4
4	Application circuits	5
5	Electrical characteristics	6
6	Typical characteristics	8
7	Package information	13
7.1	DPAK package information	14
7.2	DPAK packing information	15
7.3	SO8 package information	17
7.4	SO-8 packing information	18
7.5	TO-92 package information	19
8	Ordering informations	21
	Revision history	22
	Contents	23
	List of tables	24
	List of figures	25
	Disclaimer	26

List of tables

Table 1.	Absolute maximum ratings	4
Table 2.	Thermal data	4
Table 3.	Electrical characteristics of LM2931A33/LM2931A33Y	6
Table 4.	Electrical characteristics of LM2931A50/ LM2931A50Y	6
Table 5.	Electrical characteristics of LM2931 (adjustable version)	7
Table 6.	DPAK mechanical data	14
Table 7.	SO-8 mechanical data	18
Table 8.	SO-8 mechanical data	19
Table 9.	TO-92 mechanical data	20
Table 10.	Order code	21
Table 11.	Document revision history	22

List of figures

Figure 2.	Schematic diagram	2
Figure 3.	Pin connections (top view)	3
Figure 4.	Application circuit for fixed output	5
Figure 5.	Application circuit for adjustable output	5
Figure 6.	Output voltage vs temperature	8
Figure 7.	Output voltage vs temperature	8
Figure 8.	Reference voltage vs temperature.	8
Figure 9.	Line regulation vs temperature	8
Figure 10.	Load regulation vs temperature.	9
Figure 11.	Dropout voltage vs temperature	9
Figure 12.	Dropout voltage vs temperature	9
Figure 13.	Dropout voltage vs output current	9
Figure 14.	Output voltage vs input voltage	10
Figure 15.	Short circuit current vs drop voltage.	10
Figure 16.	Quiescent current vs temperature	10
Figure 17.	Quiescent current vs input voltage	10
Figure 18.	Quiescent current vs output current	11
Figure 19.	Supply voltage rejection vs temperature.	11
Figure 20.	Supply voltage rejection vs frequency	11
Figure 21.	Supply voltage rejection vs output current	11
Figure 22.	Stability vs C_O	11
Figure 23.	Line transient	11
Figure 24.	Load transient	12
Figure 25.	DPAK package outline	14
Figure 26.	DPAK recommended footprint (dimensions are in mm).	15
Figure 27.	DPAK tape outline.	16
Figure 28.	DPAK reel outline	17
Figure 29.	SO-8 package outline	17
Figure 30.	SO-8 recommended footprint	18
Figure 31.	SO-8 tape and reel outline	19
Figure 32.	TO-92 package outline	20

IMPORTANT NOTICE – PLEASE READ CAREFULLY

STMicroelectronics NV and its subsidiaries (“ST”) reserve the right to make changes, corrections, enhancements, modifications, and improvements to ST products and/or to this document at any time without notice. Purchasers should obtain the latest relevant information on ST products before placing orders. ST products are sold pursuant to ST’s terms and conditions of sale in place at the time of order acknowledgement.

Purchasers are solely responsible for the choice, selection, and use of ST products and ST assumes no liability for application assistance or the design of Purchasers’ products.

No license, express or implied, to any intellectual property right is granted by ST herein.

Resale of ST products with provisions different from the information set forth herein shall void any warranty granted by ST for such product.

ST and the ST logo are trademarks of ST. All other product or service names are the property of their respective owners.

Information in this document supersedes and replaces information previously supplied in any prior versions of this document.







© 2018 STMicroelectronics – All rights reserved

Looking for pricing, stock, or lifecycle information?

Click below to explore more details on WIN SOURCE:

-  [View LM2931BDT50 on WIN SOURCE](#)
-  [STMicroelectronics](#) Information

Optimize Your Supply Chain with WIN SOURCE Solutions

-  Global Sourcing Solution
-  Obsolete Management
-  Cost Control Management
-  Shortage Management
-  Alternative Solution
-  Excess Inventory Management