

**STRUCTURE**                    Silicon Monolithic Integrated circuit  
**TYPE**                            1.0A Low-Dropout Voltage Regulator with Shut down Switch (Adjustable)  
**PRODUCT SERIES**            **B A O O B C O W F**  
**FEATURES**                    •Maximum Output Current : 0.5A  
                                       •High Precision Output Voltage :  $\pm 2\%$

○ABSOLUTE MAXIMUM RATINGS (Ta=25°C)

Parameter	Symbol	Limits	Unit
Supply Voltage            ※1	Vcc	-0.3~18.0	V
Control Input Voltage	VCTL	-0.3~Vcc	V
Power dissipation        ※2	Pd	687.6	mW
Operating temperature range	Topr	-40~105	°C
Power dissipation	Tstg	-55~+150	°C
Junction temperature	Tjmax	150	°C

※1 Do not however exceed Pd.

※2 Derating in done at 5.5mW/°C for operating above Ta=25°C.

○OPERATING CONDITIONS (Ta=-40~105°C, Do not however exceed Pd.)

Parameter	Symbol	Min.	Max.	Unit
Input Voltage	Vcc	3.0	16.0	V
Output Current	Io	-	0.5	A
Output Voltage	VOUT	1.5	12.0	V
Control Input Voltage	VCTL	0	Vcc	V

NOTE : The product described in this specification is a strategic product (and/or service) subject to COCOM regulations. It should not be exported without authorization from the appropriate government.

NOTE : This product is not designed for protection against radioactive rays.

Status of this document

The Japanese version of this document is the formal specification.

A customer may use this translation version only for a reference to help reading the formal version.

If there are any differences in translation version of this document, formal version takes priority.

○ELECTRICAL CHARACTERISTICS

Unless otherwise specified, Ta=25°C, Vcc=3.3V(Vo=1.5V,1.8V,2.5V), Vcc=5.0V(Vo=3.0V,3.3V), Vcc=Vo+3.0V(Vo≥5.0V)

Parameter	Symbol	Limit			Unit	Conditions
		Min.	Typ.	Max.		
Shut Down Current	I <sub>sd</sub>	—	0	10	μA	V <sub>ctl</sub> =0V, I <sub>o</sub> =0mA (OFF MODE)
Bias Current	I <sub>b</sub>	—	0.5	0.9	mA	I <sub>o</sub> =0mA
C pin Voltage	V <sub>c</sub>	1.237	1.250	1.263	V	I <sub>o</sub> =50mA
Dropout Voltage1	ΔV <sub>d</sub>	—	0.3	0.5	V	I <sub>o</sub> =500mA, V <sub>cc</sub> =2.5V
Peak Output	I <sub>o</sub>	1.0	—	—	A	
Ripple Rejection	R.R.	45	55	—	dB	f=120Hz, e <sub>in</sub> *4=-20dBV, I <sub>o</sub> =100mA
Line Regulation	Reg.I	—	5	60	mV	V <sub>cc</sub> =4.5V→16V, I <sub>o</sub> =200mA
Load Regulation	Reg.L	—	5	60	mV	I <sub>o</sub> =5mA→1.5A
Temperature Coefficient of Output Voltage	T <sub>co</sub> ※3	—	±0.02	—	%/°C	I <sub>o</sub> =5mA, T <sub>j</sub> =0~125°C
Output Short Current	I <sub>os</sub>	—	0.6	—	A	V <sub>cc</sub> =16V
CTL ON Mode Voltage	V <sub>th1</sub>	2.0	—	—	V	ACTIVE MODE, I <sub>o</sub> =0mA
CTL OFF Mode Voltage	V <sub>th2</sub>	—	—	0.8	V	OFF MODE, I <sub>o</sub> =0mA
CTL Input Current	I <sub>in</sub>	40	80	130	μA	I <sub>o</sub> =0mA

※3 Designed Guarantee. (Outgoing inspection is not done on all products.)

※4 e<sub>in</sub>=input Voltage Ripple

○PHYSICAL DIMENSIONS, MARKING

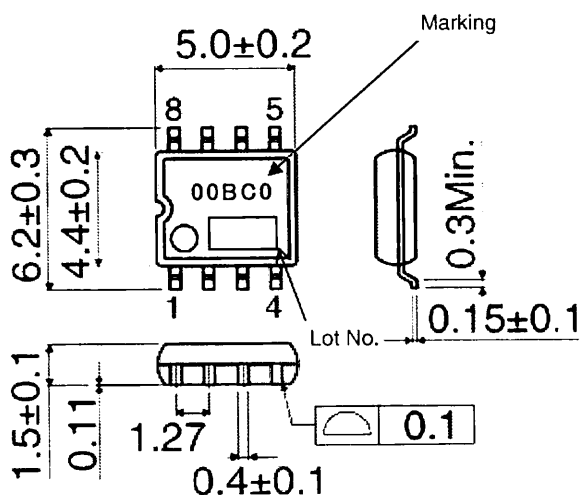

SOP8 (UNIT : mm)

○BLOCK DIAGRAM

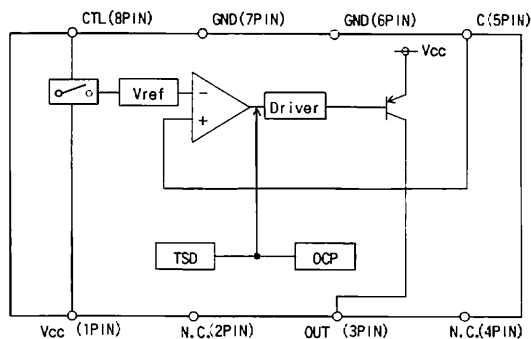

○PIN NO. , PIN NAME

Pin No.	Pin Name
1	Vcc
2	N.C.
3	OUT
4	N.C.
5	C
6	GND
7	GND
8	CTL

※ Please refer to technical note concerning application circuit, and etc.

○NOTES FOR USE

- 1. Absolute maximum range**  
 Absolute Maximum Ratings are those values beyond which the life of a device may be destroyed we cannot be defined the failure mode, such as short mode or open mode.  
 Therefore physical security countermeasure, like fuse, is to be given when a specific mode to be beyond absolute maximum ratings is considered.
- 2. GND pin voltage**  
 GND terminal should be connected the lowest voltage, under all conditions. And all terminals except GND should be under GND terminal voltage under all conditions including transient situations.
- 3. Power dissipation**  
 If IC is used on condition that the power loss is over the power dissipation, the reliability will become worse by heat up, such as reduced output current capability.  
 Also, be sure to use this IC within a power dissipation range allowing enough of margin.
- 4. Electrical characteristics described in these specifications may vary, depending on temperature, supply voltage, external circuits and other conditions. Therefore, be sure to check all relevant factors, including transient characteristics.**
- 5. Be sure to connect a capacitor with capacitance of at least 22μF, including temperature characteristics and variation, to prevent oscillation between the Vo and GND. Note that if the capacity of the capacitor changes due to factors such as changes in temperature or ESR, oscillation may occur, and the original characteristics of the IC may not be realized. For example, when a ceramic capacitor is employed, oscillation will be generated because the series resistance is too small. Please take countermeasures to prevent this, such as adding a series resistor. Standard electrolytic capacitors are subject to extremely large capacitance and ESR fluctuations due to temperature conditions. Particularly at low temperature, capacity is decreased, while ESR grows larger, conditions which increase the vulnerability to oscillation. Therefore, be certain to check for the presence of oscillation.**  
 In respect to the proper ESR range, select a capacitor that meets the conditions in the figure below for stable operation range. Note, however, that the stable range suggested in the figure depends on the IC and the resistance load involved, and can vary with the board's wiring impedance, input impedance, and/or load impedance. Therefore, be certain to ascertain the final status of these items for actual use.  
 Keep capacitor capacitance within a range of 22μF~1000μF. It is also recommended that a 0.33μF bypass capacitor be connected as close to the input pin-GND as location possible. However, in situations such as rapid fluctuation of the input voltage or the load, please check the operation in real application to determine proper capacitance.

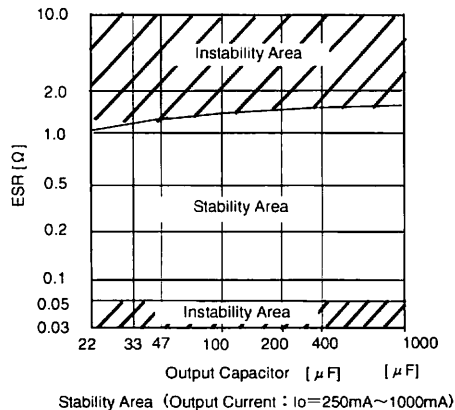
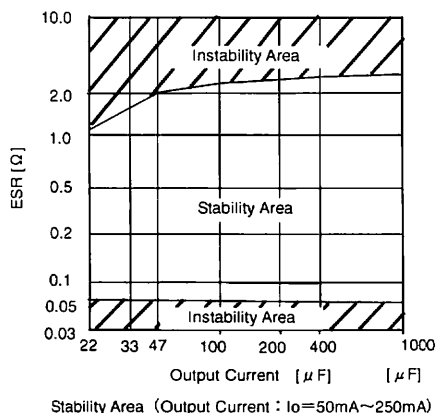

6. Overcurrent protection circuit

The built-in overcurrent protection circuit is designed to respond to the output current and prevent destruction of the IC from load short circuits; however, it is only effective in protecting the IC from destruction in sudden overcurrent accidents. The protection circuit is not to be used continuously, or for transitions. In executing thermal design, bear in mind that overcurrent protection has negative characteristic according with the temperature.

7. Thermal shutdown circuit

A built-in internal shutdown (TSD) circuit is provided to protect the IC from heat destruction. Operation has to be done within the allowable loss range, but in continuous use beyond the range, chip temperature  $T_j$  will increase to the threshold, activating the TSD circuit and turning the output power  $P_o$  OFF. Once the chip temperature  $T_j$  returns to the normal range, the circuit is automatically restored. Note that the TSD circuit is designed to operate over the maximum absolute rating. Therefore, make absolutely certain not to use the TSD function in set design.

8. Mounting Failures

Mounting failure, such as misdirection or mismount, may cause a malfunction in the device.

9. Internal circuits or elements may be damaged when  $V_{cc}$  and pin voltage are reversed. For example,  $V_{cc}$  short circuit to GND while a external capacitor is charged. Output pin capacitor is recommended no larger than  $1000\mu\text{F}$ . In addition, inserting a  $V_{cc}$  series countercurrent prevention diode, or a bypass diode between the various pins and the  $v_{cc}$ , is recommended.

10. Malfunction may be happened when the device is used in the strong electromagnetic field.

11. We recommend to put Diode for protection purpose in case of output pin connected with large load of impedance or reserve current occurred at initial and output off.

12. Precautions for board inspection

Connecting low-impedance capacitors to run inspections with the board may produce stress on the IC. Therefore, be certain to use proper discharge procedure before each process of the test operation. To prevent electrostatic accumulation and discharge in the assembly process, thoroughly ground yourself and any equipment that could sustain ESD damage, and continue observing ESD-prevention procedures in all handling, transfer and storage operations. Before attempting to connect components to the test setup, make certain that the power supply is OFF. Likewise, be sure the power supply is OFF before removing any component connected to the test setup.

13. GND pattern

When both a small-signal GND and high current GND are present, single-point grounding (at the set standard point) is recommended, in order to separate the small-signal and high current patterns, and to be sure the voltage change stemming from the wiring resistance and high current does not cause any voltage change in the small-signal GND. In the same way, care must be taken to avoid voltage fluctuations in any connected external component GND.

### Notes

- No technical content pages of this document may be reproduced in any form or transmitted by any means without prior permission of ROHM CO.,LTD.
- The contents described herein are subject to change without notice. The specifications for the product described in this document are for reference only. Upon actual use, therefore, please request that specifications to be separately delivered.
- Application circuit diagrams and circuit constants contained herein are shown as examples of standard use and operation. Please pay careful attention to the peripheral conditions when designing circuits and deciding upon circuit constants in the set.
- Any data, including, but not limited to application circuit diagrams information, described herein are intended only as illustrations of such devices and not as the specifications for such devices. ROHM CO.,LTD. disclaims any warranty that any use of such devices shall be free from infringement of any third party's intellectual property rights or other proprietary rights, and further, assumes no liability of whatsoever nature in the event of any such infringement, or arising from or connected with or related to the use of such devices.
- Upon the sale of any such devices, other than for buyer's right to use such devices itself, resell or otherwise dispose of the same, no express or implied right or license to practice or commercially exploit any intellectual property rights or other proprietary rights owned or controlled by
- ROHM CO., LTD. is granted to any such buyer.
- Products listed in this document are no antiradiation design.

The products listed in this document are designed to be used with ordinary electronic equipment or devices (such as audio visual equipment, office-automation equipment, communications devices, electrical appliances and electronic toys).

Should you intend to use these products with equipment or devices which require an extremely high level of reliability and the malfunction of which would directly endanger human life (such as medical instruments, transportation equipment, aerospace machinery, nuclear-reactor controllers, fuel controllers and other safety devices), please be sure to consult with our sales representative in advance.

#### About Export Control Order in Japan

Products described herein are the objects of controlled goods in Annex 1 (Item 16) of Export Trade Control Order in Japan.

In case of export from Japan, please confirm if it applies to "objective" criteria or an "informed" (by MITI clause) on the basis of "catch all controls for Non-Proliferation of Weapons of Mass Destruction.

Thank you for your accessing to ROHM product informations.  
More detail product informations and catalogs are available,  
please contact your nearest sales office.

Please contact our sales offices for details ;

U.S.A / San Diego	TEL : +1(858)625-3630	FAX : +1(858)625-3670
Atlanta	TEL : +1(770)754-5972	FAX : +1(770)754-0691
Dallas	TEL : +1(972)312-8818	FAX : +1(972)312-0330
Germany / Dusseldorf	TEL : +49(2154)9210	FAX : +49(2154)921400
United Kingdom / London	TEL : +44(1)908-282-666	FAX : +44(1)908-282-528
France / Paris	TEL : +33(0)1 56 97 30 60	FAX : +33(0) 1 56 97 30 80
China / Hong Kong	TEL : +852(2)740-6262	FAX : +852(2)375-8971
Shanghai	TEL : +86(21)6279-2727	FAX : +86(21)6247-2066
Dilian	TEL : +86(411)8230-8549	FAX : +86(411)8230-8537
Beijing	TEL : +86(10)8525-2483	FAX : +86(10)8525-2489
Taiwan / Taipei	TEL : +866(2)2500-6956	FAX : +866(2)2503-2869
Korea / Seoul	TEL : +82(2)8182-700	FAX : +82(2)8182-715
Singapore	TEL : +65-6332-2322	FAX : +65-6332-5662
Malaysia / Kuala Lumpur	TEL : +60(3)7958-8355	FAX : +60(3)7958-8377
Philippines / Manila	TEL : +63(2)807-6872	FAX : +63(2)809-1422
Thailand / Bangkok	TEL : +66(2)254-4890	FAX : +66(2)256-6334

Japan /  
(Internal Sales)



Tokyo	2-1-1, Yaesu, Chuo-ku, Tokyo 104-0082	TEL : +81(3)5203-0321	FAX : +81(3)5203-0300
Yokohama	2-4-8, Shin Yokohama, Kohoku-ku, Yokohama, Kanagawa 222-8575	TEL : +81(45)476-2131	FAX : +81(45)476-2128
Nagoya	Dainagayo Building 9F 3-28-12, Meieki, Nakamura-ku, Nagoya, Aichi 450-0002	TEL : +81(52)581-8521	FAX : +81(52)561-2173
Kyoto	579-32 Higashi Shiokouji-cho, Karasuma Nishi-iru, Shiokoujidori, Shimogyo-ku, Kyoto 600-8216	TEL : +81(75)311-2121	FAX : +81(75)314-6559

(Contact address for overseas customers in Japan)

Yokohama	TEL : +81(45)476-9270	FAX : +81(045)476-9271
----------	-----------------------	------------------------

## Looking for pricing, stock, or lifecycle information?

Click below to explore more details on WIN SOURCE:

-  [View BA00BC0WF-E2 on WIN SOURCE](#)
-  [Rohm Semiconductor Information](#)

## Optimize Your Supply Chain with WIN SOURCE Solutions

-  Global Sourcing Solution
-  Obsolete Management
-  Cost Control Management
-  Shortage Management
-  Alternative Solution
-  Excess Inventory Management