

TEA1610P; TEA1610T

Zero-voltage-switching resonant converter controller

Rev. 03 — 26 March 2007

Product data sheet

1. General description

The TEA1610 is a monolithic integrated circuit implemented in a high-voltage Diffusion Metal Oxide Semiconductor (DMOS) process. The circuit is a high voltage controller for a zero-voltage switching resonant converter. The IC provides the drive function for two discrete power MOSFETs in a half-bridge configuration. It also includes a level-shift circuit, an oscillator with accurately-programmable frequency range, a latched shut-down function and a transconductance error amplifier.

To guarantee an accurate 50 % switching duty factor, the oscillator signal passes through a divide-by-two flip-flop before being fed to the output drivers.

The circuit is very flexible and enables a broad range of applications for different mains voltages.

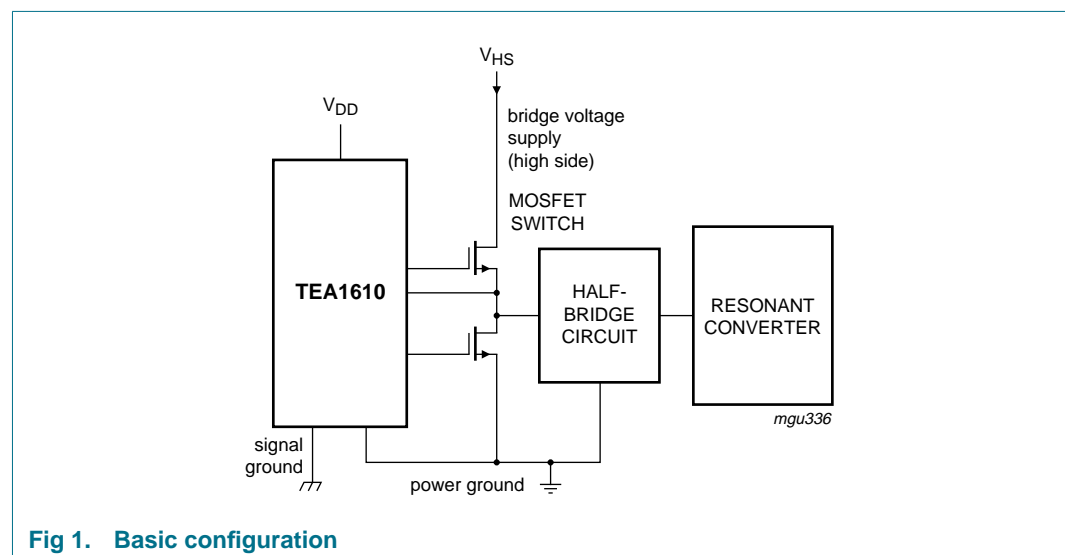

Fig 1. Basic configuration

2. Features

- Integrated high voltage level-shift function
- Integrated high voltage bootstrap diode
- Low start-up current (green function)
- Adjustable dead time
- Transconductance error amplifier for ultra high-ohmic regulation feedback
- Latched shut-down circuit for overcurrent and overvoltage protection
- Adjustable minimum and maximum frequencies
- Undervoltage lockout

3. Applications

- TV and monitor power supplies
- High voltage power supplies

4. Quick reference data

Table 1. Quick reference data

Symbol	Parameter	Conditions	Min	Typ	Max	Unit
V_{HS}	high side driver voltage		0	-	600	V
$I_{GH(source)}$	high side output source current	$V_{DD(F)} = 13\text{ V};$ $V_{SH} = 0\text{ V};$ $V_{GH} = 0\text{ V}$	-135	-180	-225	mA
$I_{GL(source)}$	low side output source current	$V_{GL} = 0\text{ V}$	-135	-180	-225	mA
$I_{GH(sink)}$	high side output sink current	$V_{DD(F)} = 13\text{ V};$ $V_{SH} = 0\text{ V};$ $V_{GH} = 13\text{ V}$	-	300	-	mA
$I_{GL(sink)}$	low side output sink current	$V_{GL} = 14\text{ V}$	-	300	-	mA
$f_{bridge(max)}$	maximum bridge frequency	$C_F = 100\text{ pF};$ $I_{IFS} = 1\text{ mA};$ $I_{IRS} = 200\text{ }\mu\text{A};$ $f_{bridge} = \frac{f_{OSC}}{2}$	[1] 450	500	550	kHz
$V_{I(CM)}$	common mode input voltage		[2] -	-	2.5	V

[1] The frequency of the oscillator depends on the value of capacitor C_f , the peak-to-peak voltage swing V_{CF} , and the charge/discharge currents $I_{CF(ch)}$ and $I_{CF(dis)}$.

[2] This parameter applies specifically to the error amplifier.

5. Ordering information

Table 2. Ordering information

Type number	Package		Version
	Name	Description	
TEA1610P	DIP16	plastic dual in-line package; 16 leads (300 mil); long body	SOT38-1
TEA1610T	SO16	plastic small outline package; 16 leads; body width 3.9 mm; low stand-off height	SOT109-2

6. Block diagram

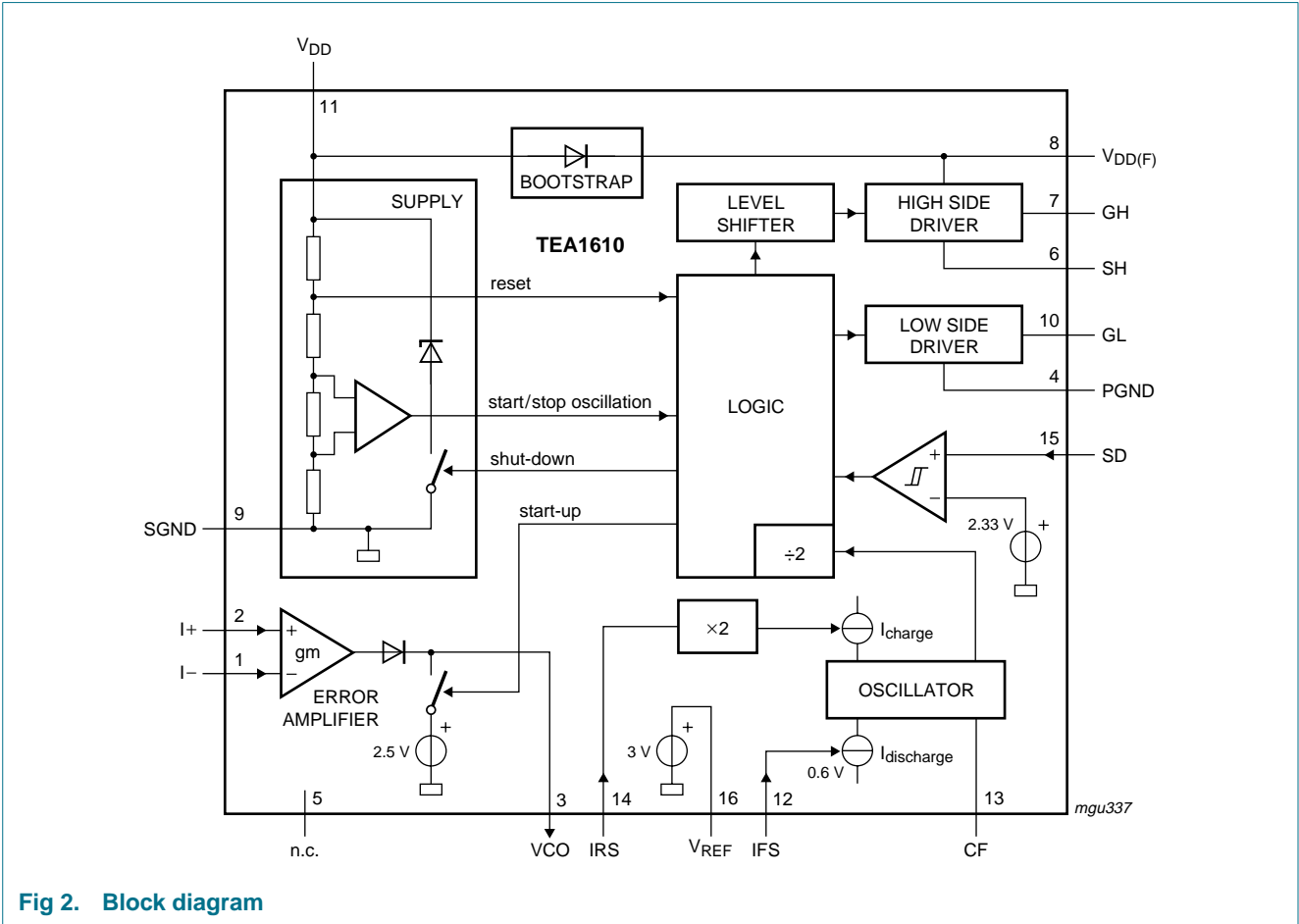

Fig 2. Block diagram

7. Pinning information

7.1 Pinning

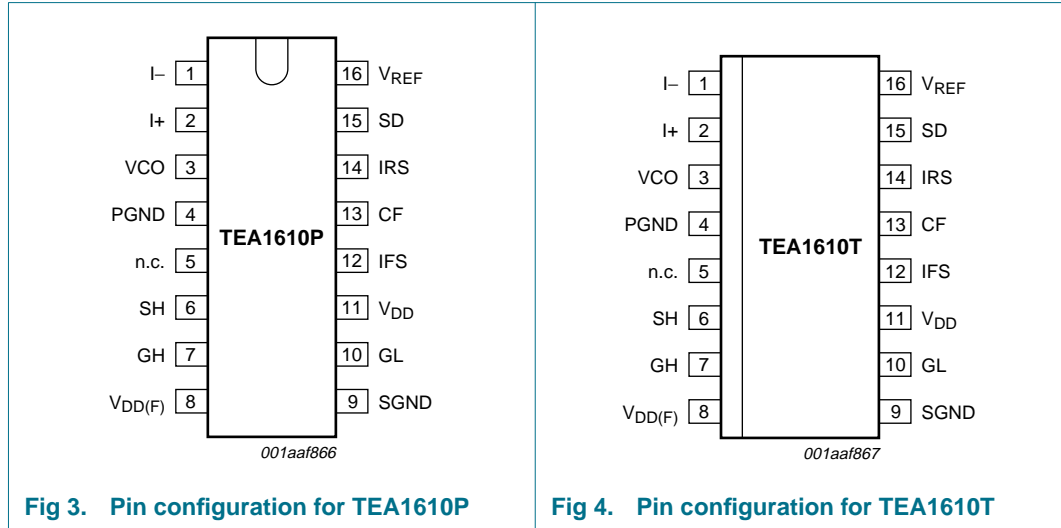

Fig 3. Pin configuration for TEA1610P

Fig 4. Pin configuration for TEA1610T

7.2 Pin description

Table 3. Pin description

Symbol	Pin	Description
I-	1	error amplifier inverting input
I+	2	error amplifier non-inverting input
VCO	3	error amplifier output
PGND	4	power ground
n.c.	5	not connected (high voltage spacer)
SH	6	high side switch source
GH	7	gate of the high side switch
V _{DD(F)}	8	floating supply voltage for the high side driver
SGND	9	signal ground
GL	10	gate of the low side switch
V _{DD}	11	supply voltage
IFS	12	oscillator discharge current input
CF	13	oscillator capacitor
IRS	14	oscillator charge current input
SD	15	shut-down input
V _{REF}	16	reference voltage

8. Functional description

8.1 Start-up

When the applied voltage at V_{DD} reaches $V_{DD(initial)}$ (see [Figure 5](#)), the low side power switch is turned-on while the high side power switch remains in the non-conducting state. This start-up output state guarantees the initial charging of the bootstrap capacitor (C_{boot}) used for the floating supply of the high side driver.

During start-up, the voltage on the frequency capacitor (C_f) is zero and defines the start-up state. The output voltage of the error amplifier is kept constant (typ. 2.5 V) and switching starts at about 80 % of the maximum frequency at the moment pin V_{DD} reaches the start level.

The start-up state is maintained until V_{DD} reaches the start level (13.5 V), the oscillator is activated and the converter starts operating.

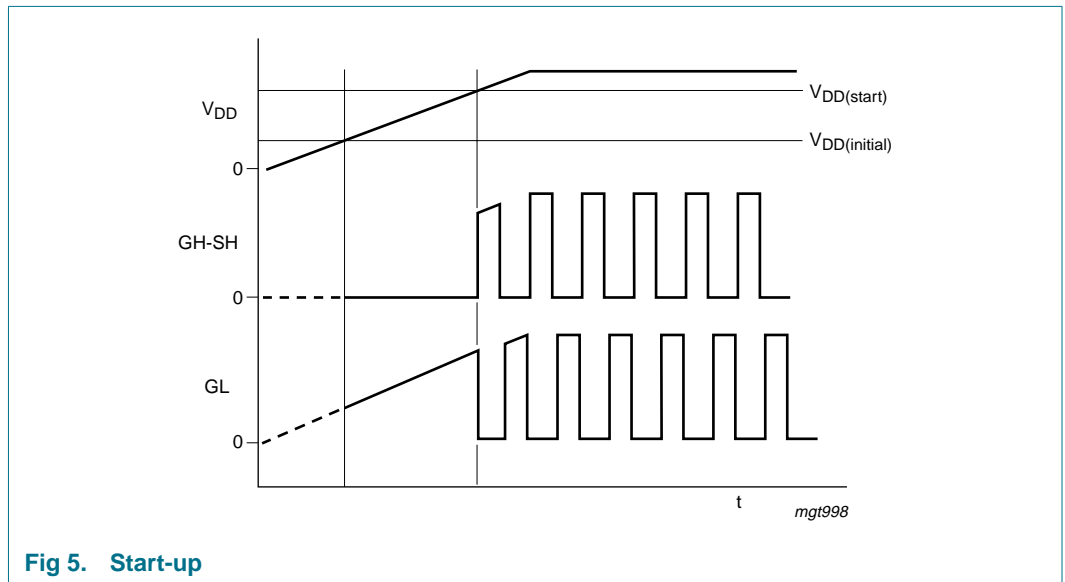

Fig 5. Start-up

8.2 Oscillator

The internal oscillator is a current-controlled oscillator that generates a sawtooth output. The frequency of the sawtooth is determined by the external capacitor C_f and the currents flowing into the IFS and IRS pins.

The minimum frequency and the dead time are set by the capacitor C_f and resistors $R_{f(min)}$ and R_{dt} . The maximum frequency is set by resistor $R_{\Delta f}$ (see Figure 10). The oscillator frequency is exactly twice the bridge frequency to achieve an accurate 50 % duty factor. An overview of the oscillator and driver signals is given in Figure 6.

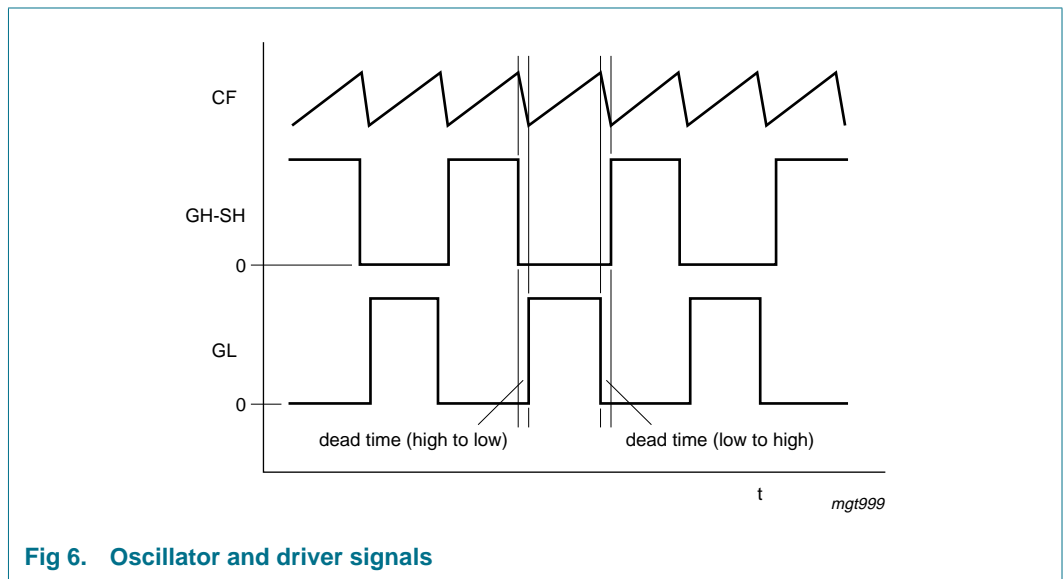

Fig 6. Oscillator and driver signals

8.3 Dead time resistor

The dead time resistor R_{dt} is connected between the 3 V reference pin (V_{REF}) and the IFS current input pin (see Figure 10). The voltage on the IFS pin is kept constant at a temperature independent value of 0.6 V. The current that flows into the IFS pin is determined by the value of resistor R_{dt} and the 2.4 V voltage drop across this resistor. The IFS input current equals the discharge current of capacitor C_f and determines the falling slope of the oscillator.

The falling slope time is used to create a dead time (t_{dt}) between two successive switching actions of the half-bridge switches:

$$I_{IFS} = \frac{2.4V}{R_{dt}}$$

$$t_{dt} = \frac{C_f \times \Delta V_{Cf}}{I_{IFS}}$$

$$t_{IFS} = t_{dt}$$

8.4 Minimum frequency resistor

The $R_{f(min)}$ resistor is connected between the V_{REF} pin (3 V reference voltage) and the IRS current input (held at a temperature independent voltage level of 0.6 V). The charge current of the capacitor C_f is twice the current flowing into the IRS pin.

The $R_{f(min)}$ resistor has a voltage drop of 2.4 V and its resistance defines the minimum charge current (rising slope) of the C_f capacitor if the control current is zero. The minimum frequency is defined by this minimum charge current (I_{IRS1}) and the discharge current:

$$I_{IRS1} = \frac{2.4V}{R_{f(min)}}$$

$$t_{IRS1} = \frac{C_f \times \Delta V_{Cf}}{2 \times I_{IRS1}}$$

$$f_{osc(min)} = \frac{1}{t_{dt} + t_{IRS1}}$$

$$f_{bridge(min)} = \frac{f_{osc(min)}}{2}$$

8.5 Maximum frequency resistor

The output voltage is regulated by changing the frequency of the half-bridge converter. The maximum frequency is determined by the $R_{\Delta f}$ resistor which is connected between the error amplifier output VCO and the oscillator current input pin IRS. The current that flows through the $R_{\Delta f}$ resistor (I_{IRS2}) is added to the current flowing through the $R_{f(min)}$ resistor. As a result, the charge current I_{CF} increases and the oscillation frequency increases. As the falling slope of the oscillator is constant, the relationship between the output frequency and the charge current is not a linear function (see [Figure 7](#) and [Figure 9](#)):

$$I_{IRS2} = \frac{V_{VCO} - 0.6}{R_{\Delta f}}$$

$$t_{IRS2} = \frac{C_f \times \Delta V_{Cf}}{2 \times (I_{IRS1} + I_{IRS2})}$$

The maximum output voltage of the error amplifier and the value of $R_{\Delta f}$ determine the maximum frequency:

$$I_{IRS2(max)} = \frac{V_{VCO(max)} - 0.6}{R_{\Delta f}}$$

$$t_{IRS(min)} = \frac{C_f \times \Delta V_{Cf}}{2 \times (I_{IRS2} + I_{IRS2(max)})}$$

$$f_{osc(max)} = \frac{1}{T_{OSC}}$$

$$f_{bridge(max)} = \frac{f_{osc(max)}}{2}$$

$$T_{OSC} = t_{IRS(min)} + t_{IFS}$$

Bridge frequency accuracy is optimum in the low frequency region. At higher frequencies both the dead time and the oscillator frequency show a decay.

The frequency of the oscillator depends on the value of capacitor C_f , the peak-to-peak voltage swing V_{Cf} and the charge and discharge currents. However, at higher frequencies the accuracy decreases due to delays in the circuit.

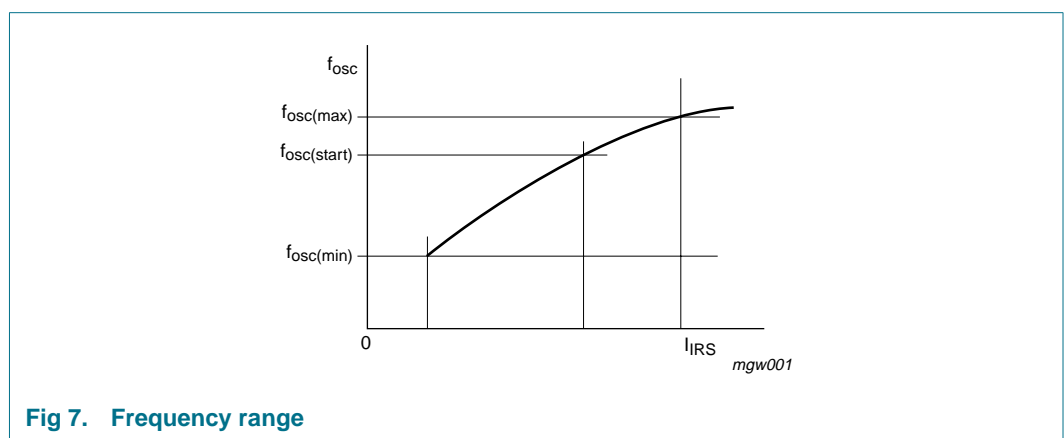

Fig 7. Frequency range

8.6 Error amplifier

The error amplifier is a transconductance amplifier. Thus the output current at pin VCO is determined by the amplifier transconductance and the differential voltage on input pins I+ and I-. The output current I_{VCO} is fed to the IRS input of the current-controlled oscillator.

The source capability of the error amplifier increases current in the IRS pin when the differential input voltage is positive. Therefore the minimum current is determined by resistor $R_{f(min)}$ and the minimum frequency setting is independent of the characteristics of the error amplifier.

The error amplifier has a maximum output current of 0.5 mA for an output voltage up to 2.5 V. If the source current decreases, the oscillator frequency also decreases resulting in a higher regulated output voltage.

During start-up, the output voltage of the amplifier is held at a constant value of 2.5 V. This voltage level defines, together with resistor $R_{\Delta f}$, the initial switching frequency of the TEA1610 after start-up.

8.7 Shut-down

The shut-down input (SD) has an accurate threshold level of 2.33 V. When the voltage on input SD reaches 2.33 V, both power switches immediately switch off and the TEA1610 enters shut-down mode.

During shut-down mode, pin V_{DD} is clamped by an internal Zener diode at 12.0 V with 1 mA input current. This clamp prevents V_{DD} rising above the rating of 14 V due to low supply current to the TEA1610 in shut-down mode.

When the TEA1610 is in the shut-down mode, it can be activated again only by lowering V_{DD} below the $V_{DD(\text{reset})}$ level (typically 5.3 V). The shut-down latch is then reset and a new start-up cycle can commence (see [Figure 8](#)).

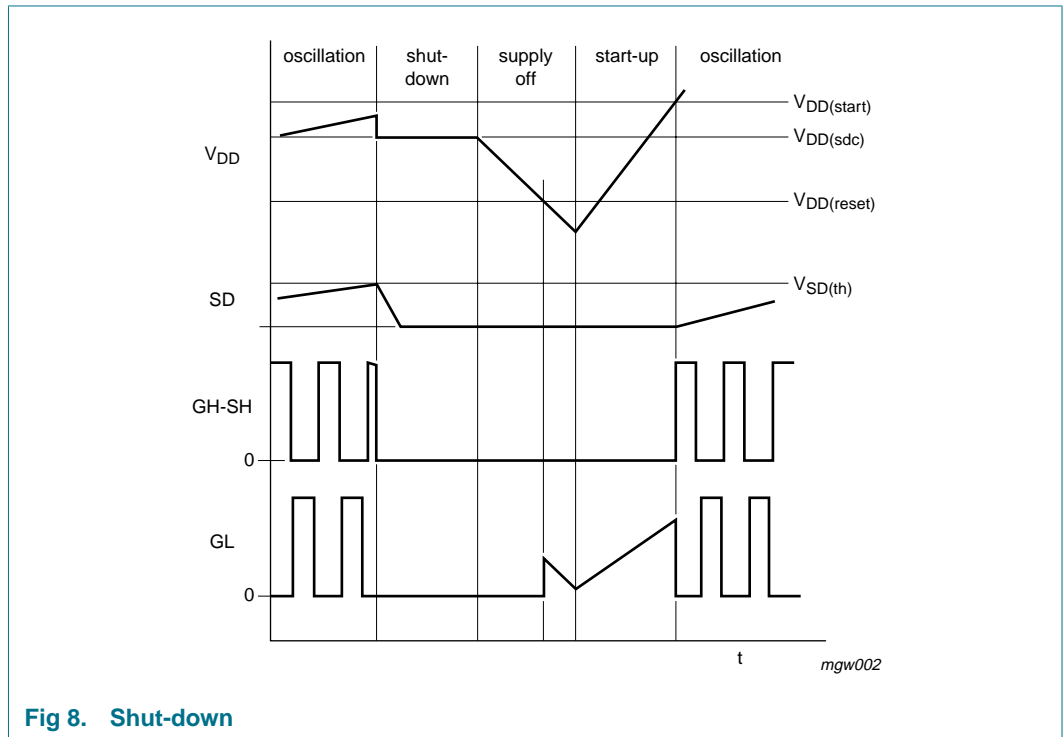

9. Limiting values

Table 4. Limiting values

In accordance with the Absolute Maximum Rating System (IEC 60134).

Symbol	Parameter	Conditions	Min	Max	Unit
Voltages					
V_{HS}	high side driver voltage		0	600	V
V_{DD}	supply voltage		[1] 0	15	V
V_{I+}	amplifier non-inverting input voltage		0	5	V
V_{I-}	amplifier inverting input voltage		0	5	V
V_{SD}	shut-down input voltage		0	5	V
Currents					
I_{IFS}	oscillator falling slope input current		-	1	mA
I_{IRS}	oscillator rising slope input current		-	1	mA
I_{REF}	V_{REF} source current		-	-2	mA
Power and temperature					
P_{tot}	total power dissipation	$T_{amb} < 70\text{ °C}$	-	0.8	W
T_{amb}	ambient temperature	operating	-25	+70	°C
T_{stg}	storage temperature		-25	+150	°C
Handling					
V_{ESD}	electrostatic discharge voltage		[2] -	2000	V
			[3] -	200	V

[1] It is recommended that a 100 nF capacitor be placed as close as possible to the V_{DD} pin (as indicated in [Figure 10](#), and in the application note).

[2] Human body model class 2: equivalent to discharging a 100 pF capacitor through a 1.5 k Ω series resistor.

[3] Machine model class 2: equivalent to discharging a 200 pF capacitor through a 0.75 μ H coil and 10 Ω resistor.

10. Thermal characteristics

Table 5. Thermal characteristics

Symbol	Parameter	Conditions	Typ	Unit
$R_{th(j-a)}$	thermal resistance from junction to ambient	in free air	100	K/W
$R_{th(j-pin)}$	thermal resistance from junction to pin		50	K/W

11. Characteristics

Table 6. Characteristics

All voltages are referred to the ground pins which must be connected externally; positive currents flow into the IC; $V_{DD} = 13\text{ V}$ and $T_{amb} = 25\text{ °C}$; tested using the circuit shown in [Figure 10](#), unless otherwise specified.

Symbol	Parameter	Conditions	Min	Typ	Max	Unit
High voltage pins $V_{DD(F)}$, GH and SH						
I_L	leakage current	$V_{DD(F)}$, V_{GH} and $V_{SH} = 600\text{ V}$	-	-	30	μA
Supply pin V_{DD}						
$V_{DD(\text{initial})}$	supply voltage for defined driver output	low side on; high side off	-	4	5	V
$V_{DD(\text{start})}$	start oscillator voltage		12.9	13.4	13.9	V
$V_{DD(\text{stop})}$	stop oscillator voltage		9.0	9.4	9.8	V
$V_{DD(\text{hys})}$	start-stop hysteresis voltage		3.8	4.0	4.2	V
$V_{DD(\text{sdcl})}$	shut-down clamp voltage	low side off; high side off; $I_{DD} = 1\text{ mA}$	11.0	12.0	13.0	V
$V_{DD(\text{reset})}$	reset voltage		4.5	5.3	6.0	V
I_{DD}	supply current:	low side on; high side off $C_f = 100\text{ pF}$; $I_{IFS} = 0.5\text{ mA}$; $I_{IRS} = 50\text{ }\mu\text{A}$; $C_o = 200\text{ pF}$ low side off; high side off; $V_{DD} = 9\text{ V}$	[1]			
	start-up		130	180	220	μA
	operating		-	2.4	-	mA
	shut-down		-	130	180	μA
Reference voltage on pin V_{REF}						
V_{REF}	reference voltage	$I_{REF} = 0\text{ mA}$	2.9	3.0	3.1	V
I_{REF}	current capability	source only	-1.0	-	-	mA
$Z_{O(VREF)}$	output impedance	$I_{REF} = -1\text{ mA}$	-	5.0	-	Ω
$\frac{\Delta V_{REF}}{\Delta T}$	temperature coefficient	$I_{REF} = 0\text{ mA}$; $T_j = 25\text{ to }150\text{ °C}$	-	-0.3	-	mV/K
Current controlled oscillator pins IRS, IFS, CF						
$I_{CF(\text{ch})(\text{min})}$	minimum CF charge current	$I_{IRS} = 15\text{ }\mu\text{A}$; $V_{CF} = 2\text{ V}$	28	30	32	μA
$I_{CF(\text{ch})(\text{max})}$	maximum CF charge current	$I_{IRS} = 200\text{ }\mu\text{A}$; $V_{CF} = 2\text{ V}$	340	380	420	μA
V_{IRS}	voltage on pin IRS	$I_{IRS} = 200\text{ }\mu\text{A}$	570	600	630	mV
$I_{CF(\text{dis})(\text{min})}$	minimum CF discharge current	$I_{IRS} = 50\text{ }\mu\text{A}$; $V_{CF} = 2\text{ V}$	47	50	53	μA
$I_{CF(\text{dis})(\text{max})}$	maximum CF discharge current	$I_{IFS} = 1\text{ mA}$; $V_{CF} = 2\text{ V}$	0.93	0.98	1.03	mA
V_{IFS}	voltage on pin IFS	$I_{IFS} = 1\text{ mA}$	570	600	630	mV
$f_{\text{bridge}(\text{min})}$	minimum bridge frequency (for stable operation)	$C_f = 100\text{ pF}$; $I_{IFS} = 0.5\text{ mA}$; $I_{IRS} = 50\text{ }\mu\text{A}$; $f_{\text{bridge}} = \frac{f_{OSC}}{2}$	188	200	212	kHz

Table 6. Characteristics ...continued

All voltages are referred to the ground pins which must be connected externally; positive currents flow into the IC; $V_{DD} = 13\text{ V}$ and $T_{amb} = 25\text{ °C}$; tested using the circuit shown in [Figure 10](#), unless otherwise specified.

Symbol	Parameter	Conditions	Min	Typ	Max	Unit
$f_{\text{bridge(max)}}$	maximum bridge frequency	$C_F = 100\text{ pF}$; $I_{\text{IFS}} = 1\text{ mA}$; $I_{\text{IRS}} = 200\text{ }\mu\text{A}$; $f_{\text{bridge}} = \frac{f_{\text{OSC}}}{2}$	[2] 450	500	550	kHz
$V_{\text{CF(L)}}$	CF trip level LOW	DC level	-	1.27	-	V
$V_{\text{CF(H)}}$	CF trip level HIGH	DC level	-	3.0	-	V
$V_{\text{Cf(p-p)}}$	C_f voltage (peak-to-peak value)		1.63	1.73	1.83	V
t_{dt}	dead time	$C_f = 100\text{ pF}$; $I_{\text{IFS}} = 0.5\text{ mA}$; $I_{\text{IRS}} = 50\text{ }\mu\text{A}$	0.37	0.40	0.43	μs
Output drivers						
$I_{\text{GH(source)}}$	high side output source current	$V_{\text{DD(F)}} = 13\text{ V}$; $V_{\text{SH}} = 0\text{ V}$; $V_{\text{GH}} = 0\text{ V}$	-135	-180	-225	mA
$I_{\text{GH(sink)}}$	high side output sink current	$V_{\text{DD(F)}} = 13\text{ V}$; $V_{\text{SH}} = 0\text{ V}$; $V_{\text{GH}} = 13\text{ V}$	-	300	-	mA
$I_{\text{GL(source)}}$	low side output source current	$V_{\text{GL}} = 0\text{ V}$	-135	-180	-225	mA
$I_{\text{GL(sink)}}$	low side output sink current	$V_{\text{GL}} = 14\text{ V}$	-	300	-	mA
$V_{\text{GH(H)}}$	high side output voltage HIGH	$V_{\text{DD(F)}} = 13\text{ V}$; $V_{\text{SH}} = 0\text{ V}$; $I_{\text{GH}} = 10\text{ mA}$	10.8	12	-	V
$V_{\text{GH(L)}}$	high side output voltage LOW	$V_{\text{DD(F)}} = 13\text{ V}$; $V_{\text{SH}} = 0\text{ V}$; $I_{\text{GH}} = 10\text{ mA}$	-	0.2	0.5	V
$V_{\text{GL(H)}}$	low side output voltage HIGH	$I_{\text{GL}} = 10\text{ mA}$	10.8	12	-	V
$V_{\text{GL(L)}}$	low side output voltage LOW	$I_{\text{GL}} = 10\text{ mA}$	-	0.2	0.5	V
$V_{\text{d(boot)}}$	bootstrap diode voltage drop	$I = 5\text{ mA}$	1.5	1.8	2.1	V
Shut-down input pin SD						
I_{SD}	input current	$V_{\text{SD}} = 2.33\text{ V}$	0	0.2	0.5	μA
$V_{\text{SD(th)}}$	threshold level		2.26	2.33	2.40	V
Error amplifier pins I+, I-, VCO						
$I_{\text{I(CM)}}$	common mode input current	$V_{\text{I(CM)}} = 1\text{ V}$	-	-0.1	-0.5	μA
$V_{\text{I(CM)}}$	common mode input voltage		-	-	2.5	V
$V_{\text{I(offset)}}$	input offset voltage	$V_{\text{I(CM)}} = 1\text{ V}$; $I_{\text{VCO}} = -10\text{ mA}$	-2	0	+2	mV
g_m	transconductance	$V_{\text{I(CM)}} = 1\text{ V}$; source only	-	330	-	$\mu\text{A/mV}$
A_o	open loop gain	$V_{\text{I(CM)}} = 1\text{ V}$	[3] -	70	-	dB
GB	gain bandwidth product	$V_{\text{I(CM)}} = 1\text{ V}$	[3] -	5	-	MHz

Table 6. Characteristics ...continued

All voltages are referred to the ground pins which must be connected externally; positive currents flow into the IC; $V_{DD} = 13\text{ V}$ and $T_{amb} = 25\text{ }^{\circ}\text{C}$; tested using the circuit shown in [Figure 10](#), unless otherwise specified.

Symbol	Parameter	Conditions	Min	Typ	Max	Unit
$V_{VCO(max)}$	maximum VCO voltage	operating	[3] 3.2	3.6	4.0	V
$I_{VCO(max)}$	maximum output current	operating; $V_{VCO} = 1\text{ V}$	-0.4	-0.5	-0.6	mA
$V_{VCO(start)}$	start VCO voltage	$I_{VCO} = 0.3\text{ mA}$	2.3	2.5	2.7	V

[1] The supply current I_{DD} increases with increasing bridge frequency to drive the capacitive load of two MOSFETs. Typical MOSFETs for the TEA1610 application are 8N50 (NXP type PHX80N50E, $Q_{g(tot)} = 55\text{ nC typ.}$) and these will increase the supply current at 150 kHz according to the following formula:

$$\Delta I_{DD} = 2 \times Q_{g(tot)} \times f_{bridge} = 2 \times 55\text{ nC} \times 150\text{ kHz} = 16.5\text{ mA}$$

[2] The frequency of the oscillator depends on the value of capacitor C_f , the peak-to-peak voltage swing V_{CF} , and the charge/discharge currents $I_{CF(ch)}$ and $I_{CF(dis)}$.

[3] This parameter is tested with a resistor of 10 k Ω connected from pin VCO to GND.

12. Application information

An application example of a zero-voltage switching resonant converter application using TEA1610 is shown in [Figure 10](#). In the off-mode the V_{DD} voltage is pulled below the stop level of 9.4 V by the 7.5 V Zener diode and the half-bridge is not driven. In the on-mode the TEA1610 starts-up with a high-ohmic bleeder resistor. After passing the level for start of oscillation, the TEA1610 is in normal operating mode and consumes the normal supply current delivered by the 12 V supply. The dead time is set by R_{dt} and C_f . The minimum frequency is adjusted by $R_{f(min)}$ and the frequency range is set by $R_{\Delta f}$. The output voltage is adjusted with a potentiometer connected to the inverting input of the error amplifier and is regulated via a feedback circuit. The shut-down input is used for overvoltage protection. To prevent interference, filter capacitors can be added on pins IFS, IRS and V_{REF} . The maximum value of each filter capacitor is 100 pF.

Practical values of the application example are given in [Figure 9](#), in which the measured oscillator frequency with capacitor $C_f = 220$ pF is shown as a function of the charge current I_{IRS} . Note that the slope of the measured frequency differs from the theoretical frequency (frequency set) calculated as described in [Section 8.5 "Maximum frequency resistor"](#).

The measured dead time is directly related to the charge current (total current flowing into pin IRS) and therefore to the oscillator frequency.

The measured frequency graph can be used to determine the required $R_{\Delta f}$ resistor for a certain maximum frequency in an application with the same value of capacitor C_f .

More application information can be found in application note *AN99011*.

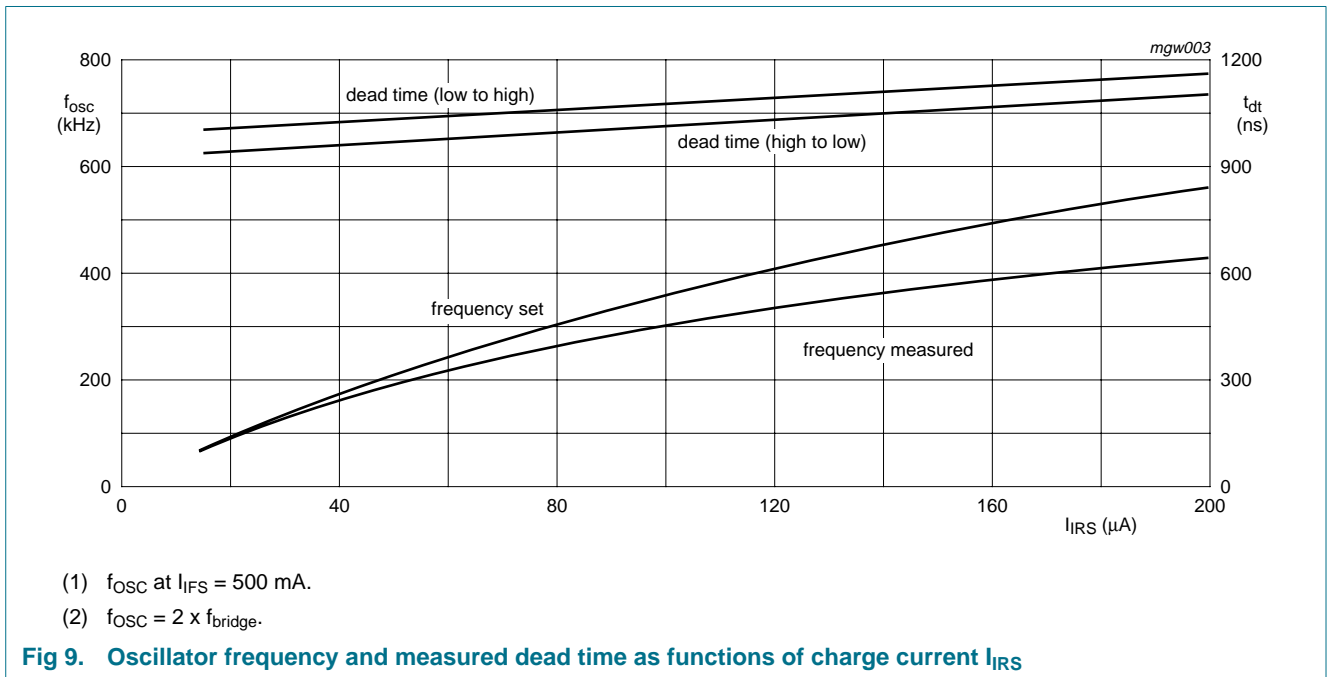

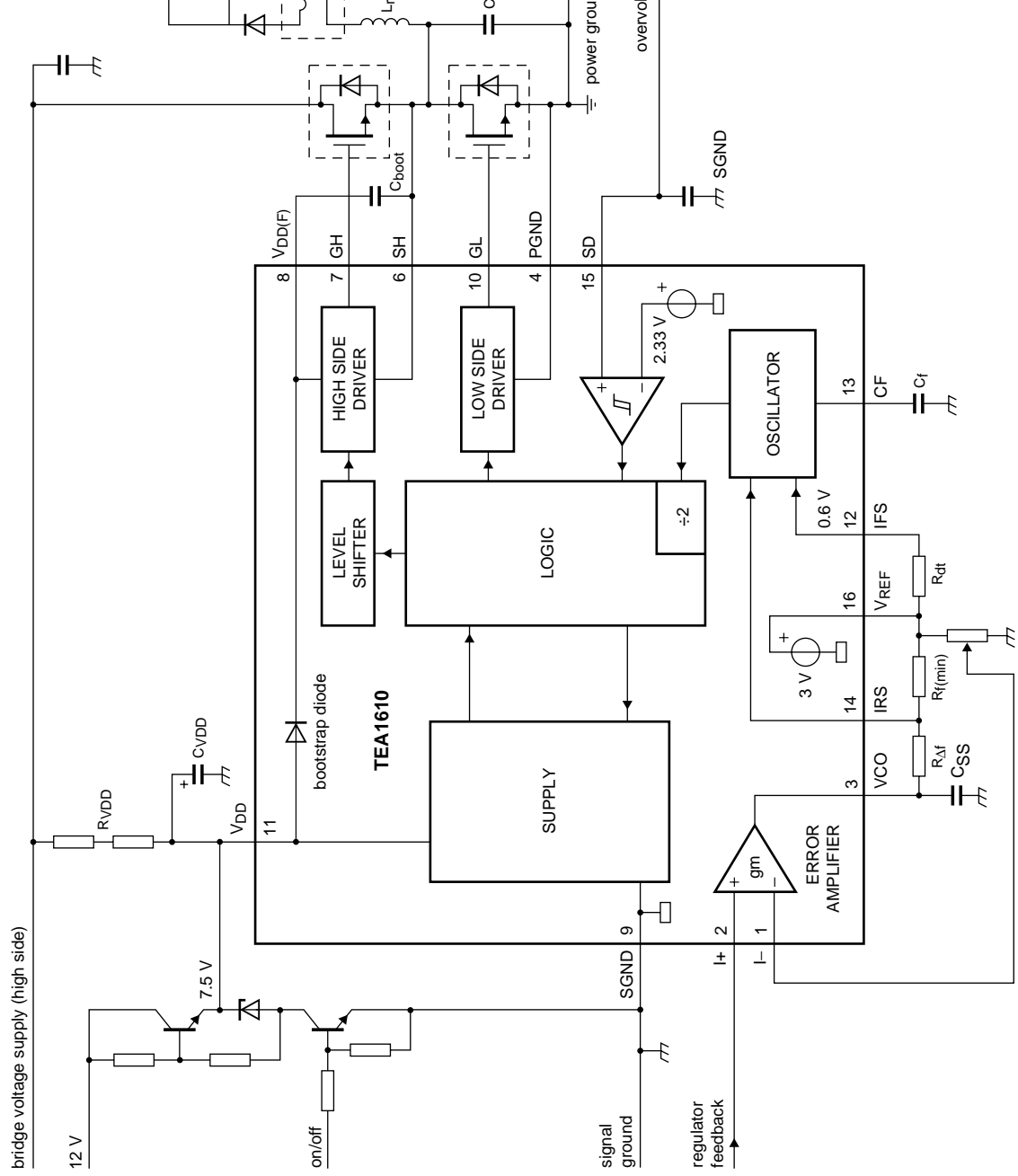

Fig 10. Application diagram

13. Test information

13.1 Quality information

The *General Quality Specification for Integrated Circuits, SNW-FQ-611* is applicable.

14. Package outline

DIP16: plastic dual in-line package; 16 leads (300 mil); long body

SOT38-1

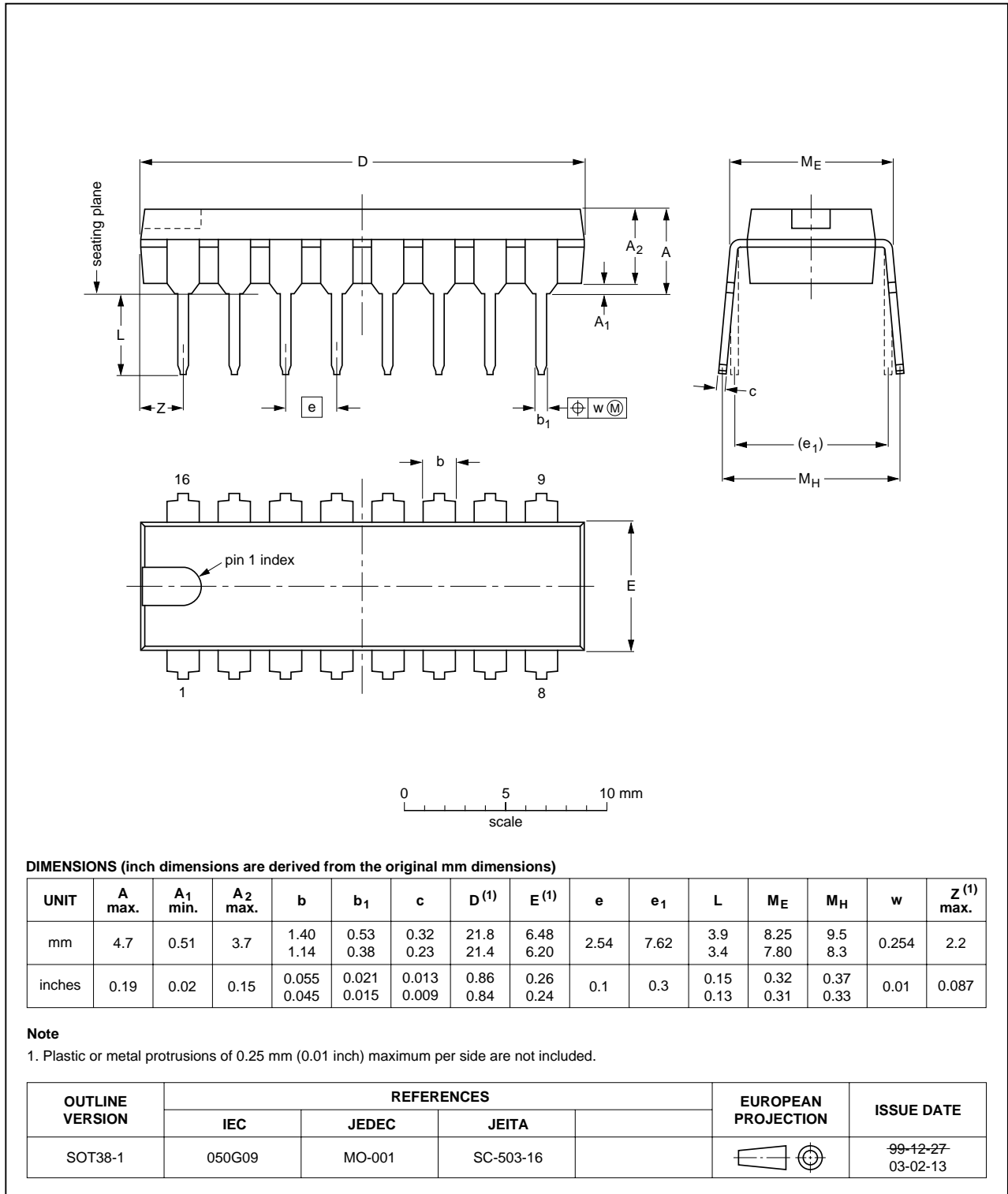

Fig 11. Package outline SOT38-1 (DIP16)

SO16: plastic small outline package; 16 leads; body width 3.9 mm; low stand-off height

SOT109-2

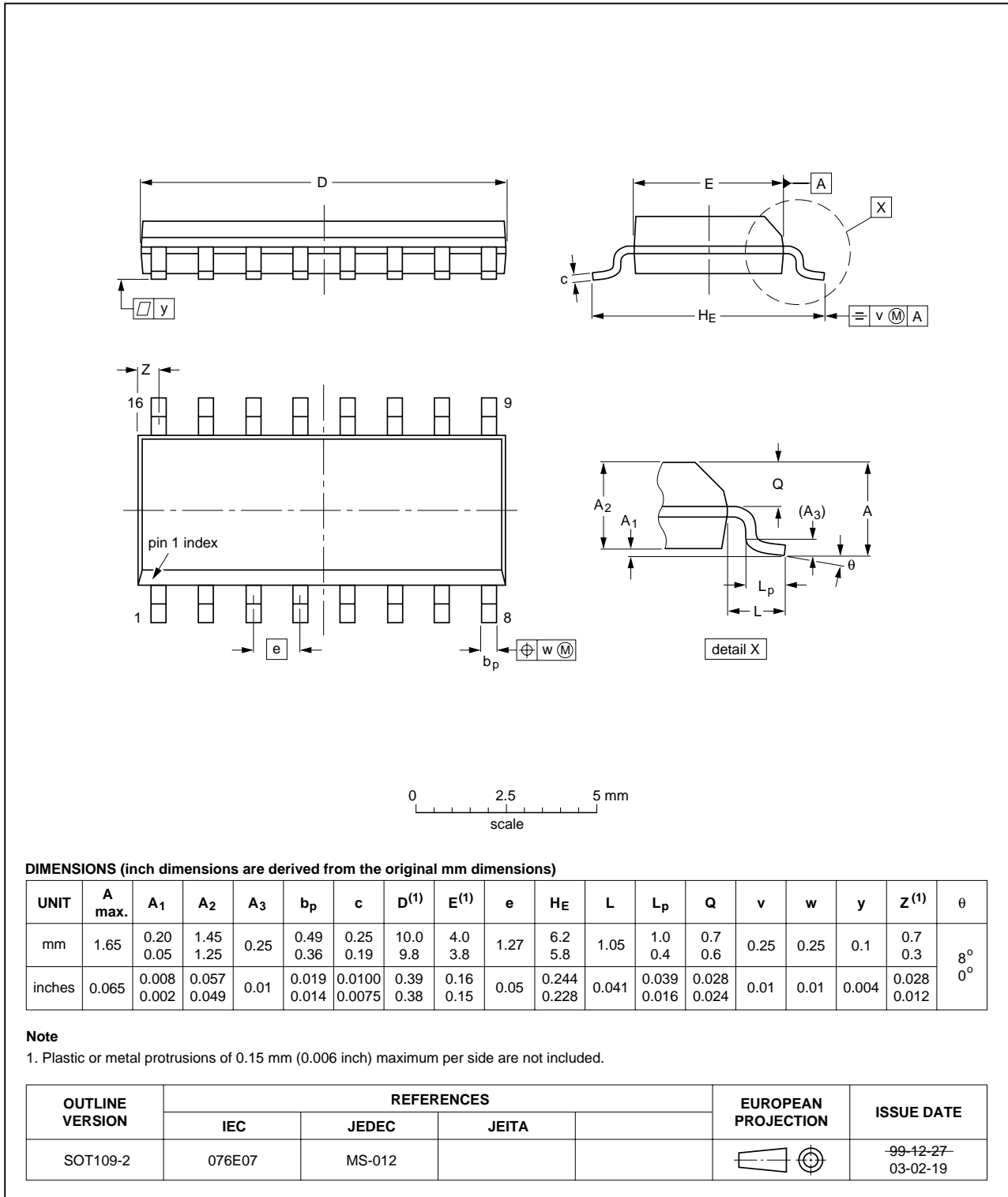

Fig 12. Package outline SOT109-2 (SO16)

15. Revision history

Table 7. Revision history

Document ID	Release date	Data sheet status	Change notice	Supersedes
TEA1610T_P_3	20070326	Product data sheet	-	TEA1610T_P_2
Modifications:	<ul style="list-style-type: none">In Table 4 "Limiting values", maximum value for V_{DD} changed from 14 V to 15 V.			
TEA1610T_P_2	20070206	Product data sheet	-	TEA1610T_P_1
Modifications:	<ul style="list-style-type: none">The format of this data sheet has been redesigned to comply with the new identity guidelines of NXP Semiconductors.Legal texts have been adapted to the new company name where appropriate.Equations modified in Section 8.4 "Minimum frequency resistor" and Section 8.5 "Maximum frequency resistor".			
TEA1610T_P_1	20010425	Product specification	-	-

16. Legal information

16.1 Data sheet status

Document status ^{[1][2]}	Product status ^[3]	Definition
Objective [short] data sheet	Development	This document contains data from the objective specification for product development.
Preliminary [short] data sheet	Qualification	This document contains data from the preliminary specification.
Product [short] data sheet	Production	This document contains the product specification.

[1] Please consult the most recently issued document before initiating or completing a design.

[2] The term 'short data sheet' is explained in section "Definitions".

[3] The product status of device(s) described in this document may have changed since this document was published and may differ in case of multiple devices. The latest product status information is available on the Internet at URL <http://www.nxp.com>.

16.2 Definitions

Draft — The document is a draft version only. The content is still under internal review and subject to formal approval, which may result in modifications or additions. NXP Semiconductors does not give any representations or warranties as to the accuracy or completeness of information included herein and shall have no liability for the consequences of use of such information.

Short data sheet — A short data sheet is an extract from a full data sheet with the same product type number(s) and title. A short data sheet is intended for quick reference only and should not be relied upon to contain detailed and full information. For detailed and full information see the relevant full data sheet, which is available on request via the local NXP Semiconductors sales office. In case of any inconsistency or conflict with the short data sheet, the full data sheet shall prevail.

16.3 Disclaimers

General — Information in this document is believed to be accurate and reliable. However, NXP Semiconductors does not give any representations or warranties, expressed or implied, as to the accuracy or completeness of such information and shall have no liability for the consequences of use of such information.

Right to make changes — NXP Semiconductors reserves the right to make changes to information published in this document, including without limitation specifications and product descriptions, at any time and without notice. This document supersedes and replaces all information supplied prior to the publication hereof.

Suitability for use — NXP Semiconductors products are not designed, authorized or warranted to be suitable for use in medical, military, aircraft, space or life support equipment, nor in applications where failure or

malfunction of a NXP Semiconductors product can reasonably be expected to result in personal injury, death or severe property or environmental damage. NXP Semiconductors accepts no liability for inclusion and/or use of NXP Semiconductors products in such equipment or applications and therefore such inclusion and/or use is at the customer's own risk.

Applications — Applications that are described herein for any of these products are for illustrative purposes only. NXP Semiconductors makes no representation or warranty that such applications will be suitable for the specified use without further testing or modification.

Limiting values — Stress above one or more limiting values (as defined in the Absolute Maximum Ratings System of IEC 60134) may cause permanent damage to the device. Limiting values are stress ratings only and operation of the device at these or any other conditions above those given in the Characteristics sections of this document is not implied. Exposure to limiting values for extended periods may affect device reliability.

Terms and conditions of sale — NXP Semiconductors products are sold subject to the general terms and conditions of commercial sale, as published at <http://www.nxp.com/profile/terms>, including those pertaining to warranty, intellectual property rights infringement and limitation of liability, unless explicitly otherwise agreed to in writing by NXP Semiconductors. In case of any inconsistency or conflict between information in this document and such terms and conditions, the latter will prevail.

No offer to sell or license — Nothing in this document may be interpreted or construed as an offer to sell products that is open for acceptance or the grant, conveyance or implication of any license under any copyrights, patents or other industrial or intellectual property rights.

16.4 Trademarks

Notice: All referenced brands, product names, service names and trademarks are the property of their respective owners.

17. Contact information

For additional information, please visit: <http://www.nxp.com>

For sales office addresses, send an email to: salesaddresses@nxp.com

18. Contents

1	General description	1
2	Features	1
3	Applications	2
4	Quick reference data	2
5	Ordering information	2
6	Block diagram	3
7	Pinning information	4
7.1	Pinning	4
7.2	Pin description	4
8	Functional description	5
8.1	Start-up	5
8.2	Oscillator	6
8.3	Dead time resistor	6
8.4	Minimum frequency resistor	7
8.5	Maximum frequency resistor	7
8.6	Error amplifier	8
8.7	Shut-down	8
9	Limiting values	10
10	Thermal characteristics	10
11	Characteristics	11
12	Application information	14
13	Test information	16
13.1	Quality information	16
14	Package outline	17
15	Revision history	19
16	Legal information	20
16.1	Data sheet status	20
16.2	Definitions	20
16.3	Disclaimers	20
16.4	Trademarks	20
17	Contact information	20
18	Contents	21

Please be aware that important notices concerning this document and the product(s) described herein, have been included in section 'Legal information'.



© NXP B.V. 2007.

All rights reserved.

For more information, please visit: <http://www.nxp.com>

For sales office addresses, please send an email to: salesaddresses@nxp.com

Date of release: 26 March 2007

Document identifier: TEA1610T_P_3

Looking for pricing, stock, or lifecycle information?

Click below to explore more details on WIN SOURCE:

- ⊖ [View TEA1610T/N6/DG,518 on WIN SOURCE](#)
- ⊖ [NXP / Nexperia Information](#)

Optimize Your Supply Chain with WIN SOURCE Solutions

- ✓ Global Sourcing Solution
- ✓ Obsolete Management
- ✓ Cost Control Management
- ✓ Shortage Management
- ✓ Alternative Solution
- ✓ Excess Inventory Management