



THE DATASHEET OF LM2623AMMX/NOPB



LM2623 General-Purpose, Gated-Oscillator-Based DC-DC Boost Converter

1 Features

- Good Efficiency Over a Very Wide Load Range
- Very Low Output Voltage Ripple
- Up to 2-MHz Switching Frequency
- 0.8-V to 14-V Operating Voltage
- 1.1-V Start-up Voltage
- 1.24-V to 14-V Adjustable Output Voltage
- Up to 2-A Load Current at Low Output Voltages
- 0.17- Ω Internal MOSFET
- Up to 90% Regulator Efficiency
- 80- μ A Typical Operating Current (Into V_{DD} Pin of Supply)
- < 2.5- μ A Ensured Supply Current In Shutdown
- Small 8-Pin VSSOP Package (Half the Footprint of Standard 8-Pin SOIC Package); 1.09-mm Package Height
- 4-mm x 4-mm Thermally Enhanced WSON Package Option

2 Applications

- Cameras, Pagers and Cell Phones
- PDAs, Palmtop Computers, GPS devices
- White LED Drive, TFT, or Scanned LCDs
- Flash Memory Programming
- Hand-Held Instruments
- 1, 2, 3, or 4 Cell Alkaline Systems
- 1, 2, or 3 Cell Lithium-ion Systems

3 Description

The LM2623 is a high-efficiency, general-purpose, step-up DC-DC switching regulator for battery-powered and low input voltage systems. It accepts an input voltage between 0.8 V and 14 V and converts it into a regulated output voltage between 1.24 V and 14 V. Efficiencies up to 90% are achievable with the LM2623.

In order to adapt to a number of applications, the LM2623 allows the designer to vary the output voltage, the operating frequency (300 kHz to 2 MHz) and duty cycle (17% to 90%) to optimize the part's performance. The selected values can be fixed or can vary with battery voltage or input to output voltage ratio. The LM2623 uses a very simple, on/off regulation mode to produce good efficiency and stable operation over a wide operating range. It normally regulates by skipping switching cycles when it reaches the regulation limit (Pulse Frequency Modulation).

Note: See [Non-Linear Effect](#) and [Choosing The Correct C3 Capacitor](#) so that any challenges with designing with this part can be taken into account before a board design/layout is finalized.

For alternative solutions, See Also: LM2700, LM2622, LM2731, LM2733, and LM2621.

Device Information⁽¹⁾

PART NUMBER	PACKAGE	BODY SIZE (NOM)
LM2623	WSON (14)	4.00 mm x 4.00 mm
	VSSOP (8)	3.00 mm x 3.00 mm

(1) For all available packages, see the orderable addendum at the end of the data sheet.

Typical Application Circuit

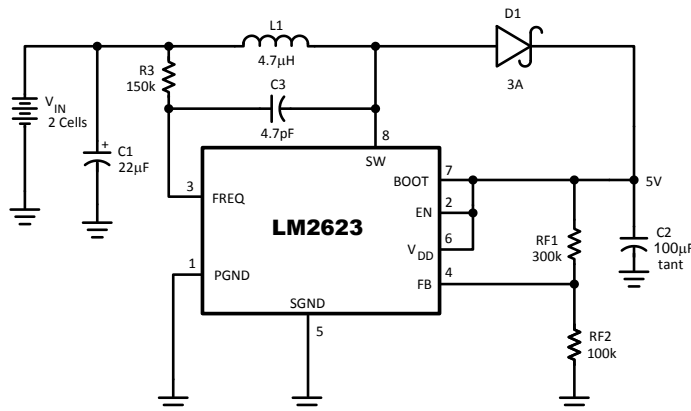

Table of Contents

1 Features	1	8 Applications And Implementation	10
2 Applications	1	8.1 Application Information	10
3 Description	1	8.2 Typical Application	10
4 Revision History	2	9 Power Supply Recommendations	12
5 Pin Configuration And Functions	3	10 Layout	12
6 Specifications	4	10.1 Layout Guidelines	12
6.1 Absolute Maximum Ratings	4	10.2 Layout Example	13
6.2 ESD Ratings	4	10.3 WSON Package Devices	13
6.3 Recommended Operating Conditions	4	11 Device And Documentation Support	14
6.4 Thermal Information	4	11.1 Device Support	14
6.5 Electrical Characteristics	5	11.2 Documentation Support	14
6.6 Typical Characteristics	5	11.3 Receiving Notification of Documentation Updates	14
7 Detailed Description	7	11.4 Community Resources	14
7.1 Overview	7	11.5 Trademarks	14
7.2 Functional Block Diagram	7	11.6 Electrostatic Discharge Caution	14
7.3 Feature Description	7	11.7 Glossary	14
7.4 Device Functional Modes	9	12 Mechanical, Packaging, And Orderable Information	14

4 Revision History

NOTE: Page numbers for previous revisions may differ from page numbers in the current version.

Changes from Revision H (November 2014) to Revision I	Page
• Changed <i>Handling Ratings</i> table to <i>ESD Ratings</i> to comply with current format	4
• Moved Storage temperature spec to <i>Abs Max</i> table	4
• Added separate row for SW pin HBM ESD rating	4
• Added condition to <i>Recommended Operating Conditions</i> table	4
• Changed Updated $R_{\theta JA}$ value for NHE package from "40 – 56" to "46.5"°C/W and DGK package from "240" to 152.5" °C/W; added additional thermal information	4

Changes from Revision G (December 2005) to Revision H	Page
• Added <i>Device Information</i> and <i>Handling Rating</i> tables, <i>Feature Description</i> , <i>Device Functional Modes</i> , <i>Application and Implementation</i> , <i>Power Supply Recommendations</i> , <i>Layout</i> , <i>Device and Documentation Support</i> , and <i>Mechanical, Packaging, and Orderable Information</i> sections; moved some curves to <i>Application Curves</i> section	1

5 Pin Configuration And Functions

**NHE Package
14-Pin WSON
Top View**

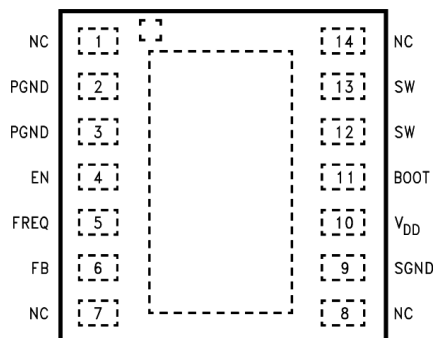

**DGK Package
8-Pin VSSOP
Top View**

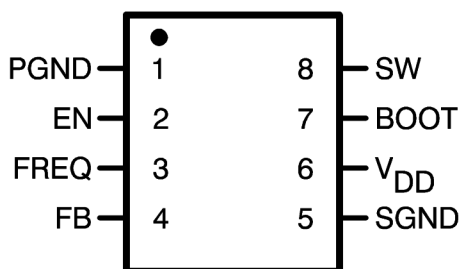

Pin Functions

PIN			TYPE	DESCRIPTION
WSON	VSSOP	NAME		
1	—	NC	N/A	No Connect
2, 3	1	PGND	GND	Power Ground (WSON Pins 2 and 3 must be shorted together).
4	2	EN	Digital	Active-Low Shutdown Input
5	3	FREQ	Analog	Frequency Adjust. An external resistor connected between this pin and a voltage source sets the switching frequency of the LM2623.
6	4	FB	Analog	Output Voltage Feedback
7	—	NC	N/A	No Connect
8	—	NC	N/A	No connect
9	5	SGND	GND	Signal Ground
10	6	V _{DD}	Power	Power Supply for Internal Circuitry
11	7	BOOT	Analog	Bootstrap Supply for the Gate Drive of Internal MOSFET Power Switch
12, 13	8	SW	Analog	Drain of the Internal MOSFET Power Switch. (WSON pins 12 and 13 must be shorted together.)
14	—	NC	N/A	No Connect
DAP	—	DAP	Thermal	To be soldered to board for enhanced thermal dissipation. To be electrically isolated/floating.

6 Specifications

6.1 Absolute Maximum Ratings⁽¹⁾⁽²⁾

	MIN	MAX	UNIT
SW pin voltage	–0.5	14.5	V
BOOT, V _{DD} , EN and FB pins	–0.5	10	V
FREQ pin		100	μA
T _{Jmax} ⁽³⁾		150	°C
Lead temp. (soldering, 5 sec)		260	°C
Power dissipation (T _A =25°C) ⁽³⁾		500	mW
Storage temperature, T _{stg}	–65	150	°C

- (1) Stresses beyond those listed under *Absolute Maximum Ratings* may cause permanent damage to the device. These are stress ratings only, which do not imply functional operation of the device at these or any other conditions beyond those indicated under *Recommended Operating Conditions*. Exposure to absolute-maximum-rated conditions for extended periods may affect device reliability.
- (2) If Military/Aerospace specified devices are required, contact the Texas Instruments Sales Office/ Distributors for availability and specifications.
- (3) The maximum power dissipation must be derated at elevated temperatures and is dictated by T_{Jmax} (maximum junction temperature), R_{θJA} (junction-to-ambient thermal resistance), and T_A (ambient temperature). The maximum allowable power dissipation at any temperature is P_{dmax} = (T_{Jmax} – T_A) / R_{θJA} or the number given in the *Absolute Maximum Ratings*, whichever is lower.

6.2 ESD Ratings

			VALUE	UNIT	
V _(ESD)	Electrostatic discharge	Human-body model (HBM), per ANSI/ESDA/JEDEC JS-001 ⁽¹⁾	All pins except SW pin	±2000	V
		Charged-device model (CDM), per JEDEC specification JESD22-C101 ⁽²⁾	SW pin (VSSOP package pin 8) (WSON package pin 12 and pin 13)	±1000	
			All pins	±500	

- (1) JEDEC document JEP155 states that 500-V HBM allows safe manufacturing with a standard ESD control process.
- (2) JEDEC document JEP157 states that 250-V CDM allows safe manufacturing with a standard ESD control process.

6.3 Recommended Operating Conditions

over operating free-air temperature range (unless otherwise noted)⁽¹⁾

	MIN	MAX	UNIT
V _{DD} pin	3	5	V
FB, EN pins	0	V _{DD}	
BOOT pin	0	10	V
Ambient temperature (T _A)	–40	85	°C

- (1) Stresses beyond those listed under *Absolute Maximum Ratings* may cause permanent damage to the device. These are stress ratings only, which do not imply functional operation of the device at these or any other conditions beyond those indicated under *Recommended Operating Conditions*. Exposure to absolute-maximum-rated conditions for extended periods may affect device reliability.

6.4 Thermal Information

THERMAL METRIC ⁽¹⁾		LM2623		UNIT
		NHE (WSON)	DGK (VSSOP)	
		14 PINS	8 PINS	
R _{θJA}	Junction-to-ambient thermal resistance	46.5	152.5	°C/W
R _{θJC(top)}	Junction-to-case (top) thermal resistance	37.7	53.9	°C/W
R _{θJB}	Junction-to-board thermal resistance	23.6	73.2	°C/W
ψ _{JT}	Junction-to-top characterization parameter	0.4	5.5	°C/W
ψ _{JB}	Junction-to-board characterization parameter	23.8	72.0	°C/W
R _{θJC(bot)}	Junction-to-case (bottom) thermal resistance	4.6	N/A	°C/W

- (1) For more information about traditional and new thermal metrics, see the *Semiconductor and IC Package Thermal Metrics* application report.

6.5 Electrical Characteristics

Limits apply for $T_J = 25^\circ\text{C}$ and $V_{DD} = V_{OUT} = 3.3\text{ V}$, unless otherwise specified.

PARAMETER	TEST CONDITION	MIN	TYP	MAX	UNIT
V_{DD_ST}	Start-up supply voltage 25°C			1.1	V
V_{IN_OP}	Minimum operating supply voltage (once started)		0.65	0.8	V
V_{FB}	FB pin voltage		1.24		V
	-40°C to 85°C	1.2028		1.2772	
V_{OUT_MAX}	Maximum output voltage		14		V
η	Efficiency	$V_{IN} = 3.6\text{ V}; V_{OUT} = 5\text{ V}; I_{LOAD} = 500\text{ mA}$	87%		
		$V_{IN} = 2.5\text{ V}; V_{OUT} = 3.3\text{ V}; I_{LOAD} = 200\text{ mA}$	87%		
D	Switch duty cycle		17		
I_{DD}	Operating quiescent current ⁽²⁾	FB Pin > 1.3 V; EN Pin at V_{DD}	80		μA
		FB Pin > 1.3 V; EN Pin at V_{DD} , -40°C to 85°C		110	
I_{SD}	Shutdown quiescent current ⁽³⁾	V_{DD} , BOOT and SW Pins at 5 V; EN Pin < 200 mV	0.01		μA
		V_{DD} , BOOT and SW Pins at 5 V; EN Pin < 200 mV, -40°C to 85°C		2.5	
I_{CL}	Switch peak current limit	LM2623A	2.2	2.85	A
I_C	Switch peak current limit	LM2623	1.2		
R_{DS_ON}	MOSFET switch on resistance		0.17		Ω
		-40°C to 85°C		0.26	
ENABLE SECTION					
V_{EN_LO}	EN pin voltage low ⁽⁴⁾	-40°C to 85°C		$0.15 V_{DD}$	V
V_{EN_HI}	EN pin voltage high ⁽⁴⁾	-40°C to 85°C	$0.7 V_{DD}$		

(1) V_{DD} tied to BOOT and EN pins. Frequency pin tied to V_{DD} through 121-K Ω resistor. $V_{DD_ST} = V_{DD}$ when start-up occurs. V_{IN} is $V_{DD} + D1$ voltage (usually 10 mV to 50 mV at start-up).

(2) This is the current into the V_{DD} pin.

(3) This is the total current into pins V_{DD} , BOOT, SW, and FREQ.

(4) When the EN pin is below V_{EN_LO} , the regulator is shut down; when it is above V_{EN_HI} , the regulator is operating.

6.6 Typical Characteristics

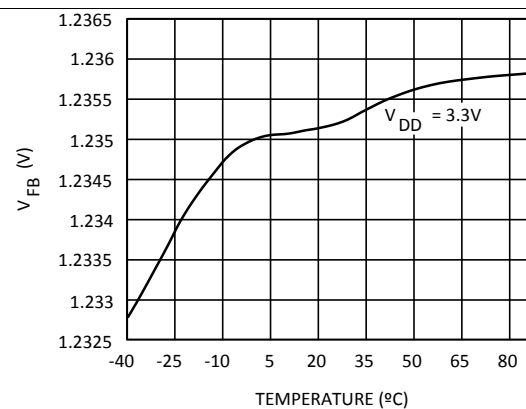
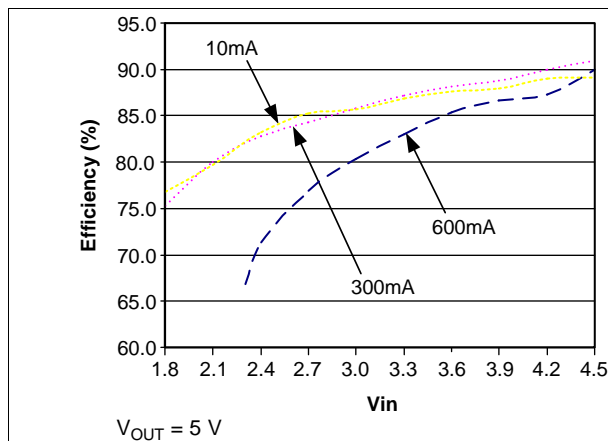

Typical Characteristics (continued)

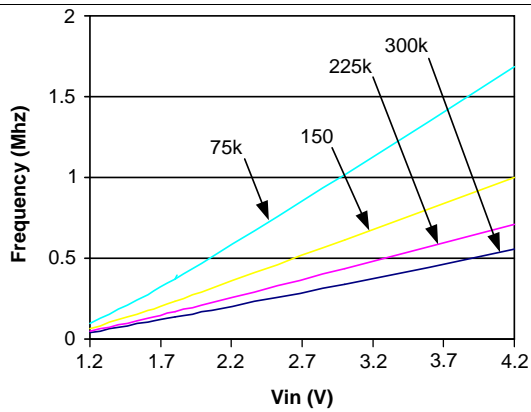

Figure 3. Frequency vs V_{IN}

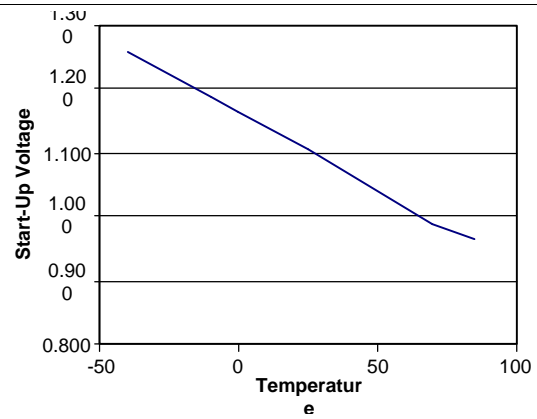

Figure 4. Maximum Start-Up Voltage vs Temperature

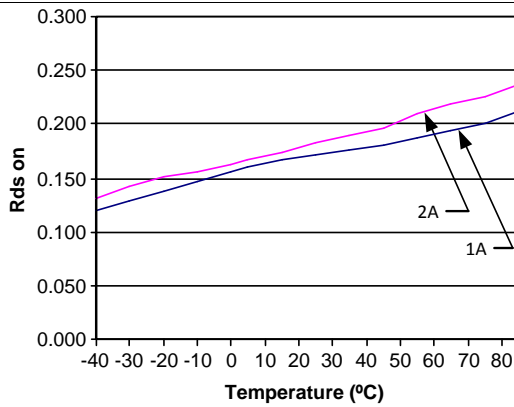

Figure 5. Typical $R_{DS(ON)}$ vs Temperature

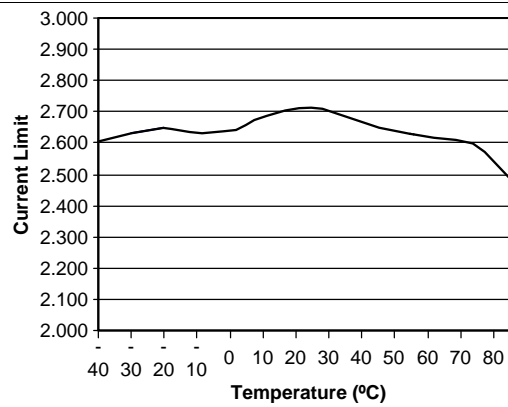

Figure 6. Typical Current Limit vs Temperature

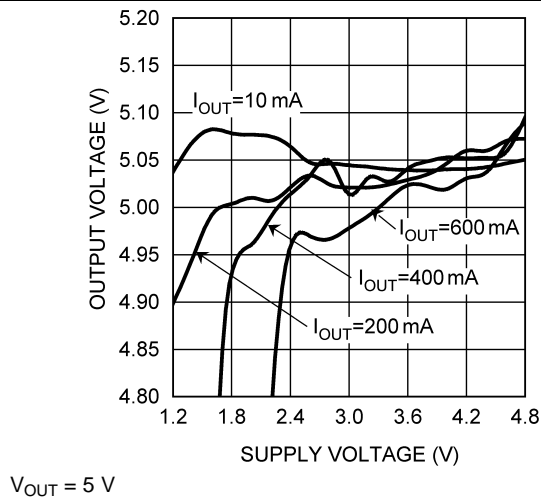

Figure 7. Output Voltage vs Supply Voltage

Feature Description (continued)

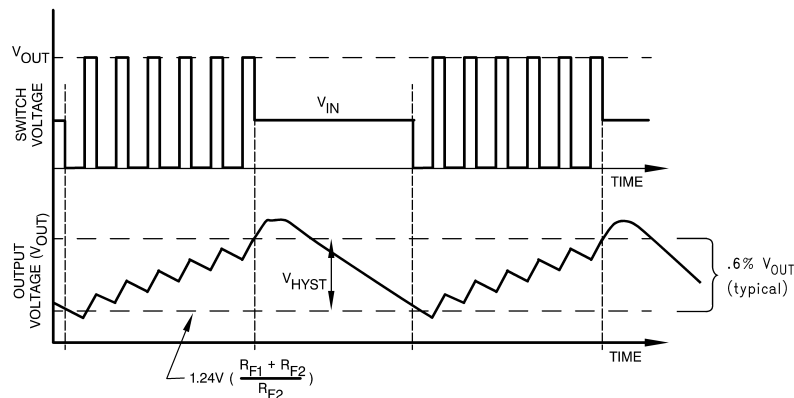

Figure 8. Typical Step-Up Regulator Waveforms

7.3.2 Cycle-To-Cycle Pfm

When the load doesn't vary over a wide range (like zero to full load), ratio adaptive circuit techniques can be used to achieve cycle to cycle PFM regulation and lower ripple (or smaller output capacitors). The key to success here is matching the duty cycle of the circuit closely to what is required by the input to output voltage ratio. This ratio then needs to be dynamically adjusted for input voltage changes (usually caused by batteries running down). The chosen ratio should allow most of the energy in each switching cycle to be delivered to the load and only a small amount to be stored. When the regulation limit is reached, the overshoot will be small and the system will settle at an equilibrium point where it adjusts the off time in each switching cycle to meet the current requirements of the load. The off time adjustment is done by exceeding the regulation limit during each switching cycle and waiting until the voltage drops below the limit again to start the next switching cycle. The current in the coil never goes to zero like it frequently does in the hysteretic operating mode of circuits with wide load variations or duty cycles that aren't matched to the input/output voltage ratio. Optimizing the duty cycle for a given set of input/output voltages conditions can be done by using the circuit values in the Application Notes.

7.3.3 Shutdown

The LM2623 features a shutdown mode that reduces the quiescent current to less than an ensured 2.5 μA over temperature. This extends the life of the battery in battery powered applications. During shutdown, all feedback and control circuitry is turned off. The regulator's output voltage drops to one diode drop below the input voltage. Entry into the shutdown mode is controlled by the active-low logic input pin EN (pin-2). When the logic input to this pin is pulled below 0.15 V_{DD} , the device goes into shutdown mode. The logic input to this pin should be above 0.7 V_{DD} for the device to work in normal stepup mode.

7.3.4 Internal Current Limit And Thermal Protection

An internal cycle-by-cycle current limit serves as a protection feature. This is set high enough (2.85 A typical, approximately 4 A maximum) so as not to come into effect during normal operating conditions. An internal thermal protection circuit disables the MOSFET power switch when the junction temperature (T_J) exceeds about 160°C. The switch is re-enabled when T_J drops below approximately 135°C.

7.4 Device Functional Modes

7.4.1 Pulse Frequency Modulation (Pfm)

Pulse Frequency Modulation is typically accomplished by switching continuously until the voltage limit is reached and skipping cycles after that to just maintain it. This results in a somewhat hysteretic mode of operation. The coil stores more energy each cycle as the current ramps up to high levels. When the voltage limit is reached, the system usually overshoots to a higher voltage than required, due to the stored energy in the coil (see [Figure 8](#)). The system will also undershoot somewhat when it starts switching again because it has depleted all the stored energy in the coil and needs to store more energy to reach equilibrium with the load. Larger output capacitors and smaller inductors reduce the ripple in these situations. The frequency being filtered, however, is not the basic switching frequency. It is a lower frequency determined by the load, the input/output voltage and the circuit parameters. This mode of operation is useful in situations where the load variation is significant. Power managed computer systems, for instance, may vary from zero to full load while the system is on and this is usually the preferred regulation mode for such systems.

7.4.2 Low Voltage Start-Up

The LM2623 can start up from voltages as low as 1.1 V. On start-up, the control circuitry switches the N-channel MOSFET continuously until the output reaches 3 V. After this output voltage is reached, the normal step-up regulator feedback and gated oscillator control scheme take over. Once the device is in regulation, it can operate down to below 0.8 V input, since the internal power for the IC can be boot-strapped from the output using the V_{DD} pin.

8 Applications And Implementation

NOTE

Information in the following applications sections is not part of the TI component specification, and TI does not warrant its accuracy or completeness. TI's customers are responsible for determining suitability of components for their purposes. Customers should validate and test their design implementation to confirm system functionality.

8.1 Application Information

The LM2623 features a shutdown mode, entry into the shutdown mode is controlled by the active-low logic input pin EN (pin 2). When the logic input to this pin is pulled below $0.15 V_{DD}$, the device goes into shutdown mode. The logic input to this pin should be above $0.7 V_{DD}$ for the device to work in normal start-up mode.

8.2 Typical Application

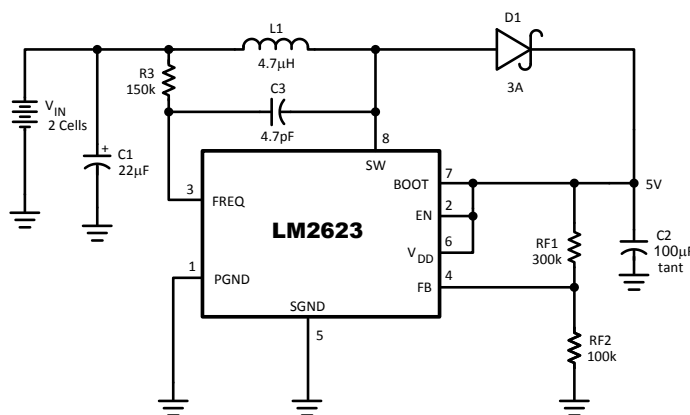

Figure 9. LM2623 Typical Application

8.2.1 Design Requirements

The LM2623 allows the designer to vary output voltage, operating frequency and duty cycle to optimize the part performance, please read [Detailed Design Procedure](#) for details.

8.2.2 Detailed Design Procedure

8.2.2.1 Non-Linear Effect

The LM2623 is very similar to the LM2621. The LM2623 is based on the LM2621, except for the fact that the LM2623 takes advantage of a non-linear effect that allows for the duty cycle to be programmable. The C3 capacitor is used to dump charge on the FREQ pin in order to manipulate the duty cycle of the internal oscillator. The part is being tricked to behave in a certain manner, in the effort to make this Pulse Frequency Modulated (PFM) boost switching regulator behave as a Pulse Width Modulated (PWM) boost switching regulator.

8.2.2.2 Choosing The Correct C3 Capacitor

The C3 capacitor allows for the duty cycle of the internal oscillator to be programmable. Choosing the correct C3 capacitor to get the appropriate duty cycle for a particular application circuit is a trial and error process. The non-linear effect that C3 produces is dependent on the input voltage and output voltage values. The correct C3 capacitor for particular input and output voltage values cannot be calculated. Choosing the correct C3 capacitance is best done by trial and error, in conjunction with the checking of the inductor peak current to make sure your not too close to the current limit of the device. As the C3 capacitor value increases, so does the duty cycle. And conversely as the C3 capacitor value decreases, the duty cycle decreases. An incorrect choice of the C3 capacitor can result in the part prematurely tripping the current limit and/or double pulsing, which could lead to the output voltage not being stable.

Typical Application (continued)

8.2.2.3 Setting The Output Voltage

The output voltage of the step-up regulator can be set by connecting a feedback resistive divider made of R_{F1} and R_{F2} . The resistor values are selected as follows:

$$R_{F1} = R_{F2} * [(V_{OUT} / 1.24) - 1] \quad (1)$$

A value of 50k to 100k is suggested for R_{F2} . Then, R_{F1} can be selected using [Equation 1](#).

8.2.2.4 V_{DD} Supply

The V_{DD} supply must be between 3 V to 5 V for the LM2623. This voltage can be bootstrapped from a much lower input voltage by simply connecting the V_{DD} pin to V_{OUT} . In the event that the V_{DD} supply voltage is not a low ripple voltage source (less than 200 millivolts), it may be advisable to use an RC filter to clean it up. Excessive ripple on V_{DD} may reduce the efficiency.

8.2.2.5 Setting The Switching Frequency

The switching frequency of the oscillator is selected by choosing an external resistor ($R3$) connected between V_{IN} and the $FREQ$ pin. See [Figure 3](#) in the [Typical Characteristics](#) section of the data sheet for choosing the $R3$ value to achieve the desired switching frequency. A high switching frequency allows the use of very small surface mount inductors and capacitors and results in a very small solution size. A switching frequency between 300 kHz and 2 MHz is recommended.

8.2.2.6 Output Diode Selection

A Schottky diode should be used for the output diode. The forward current rating of the diode should be higher than the peak input current, and the reverse voltage rating must be higher than the output voltage. Do not use ordinary rectifier diodes, since slow switching speeds and long recovery times cause the efficiency and the load regulation to suffer.

8.2.3 Application Curves

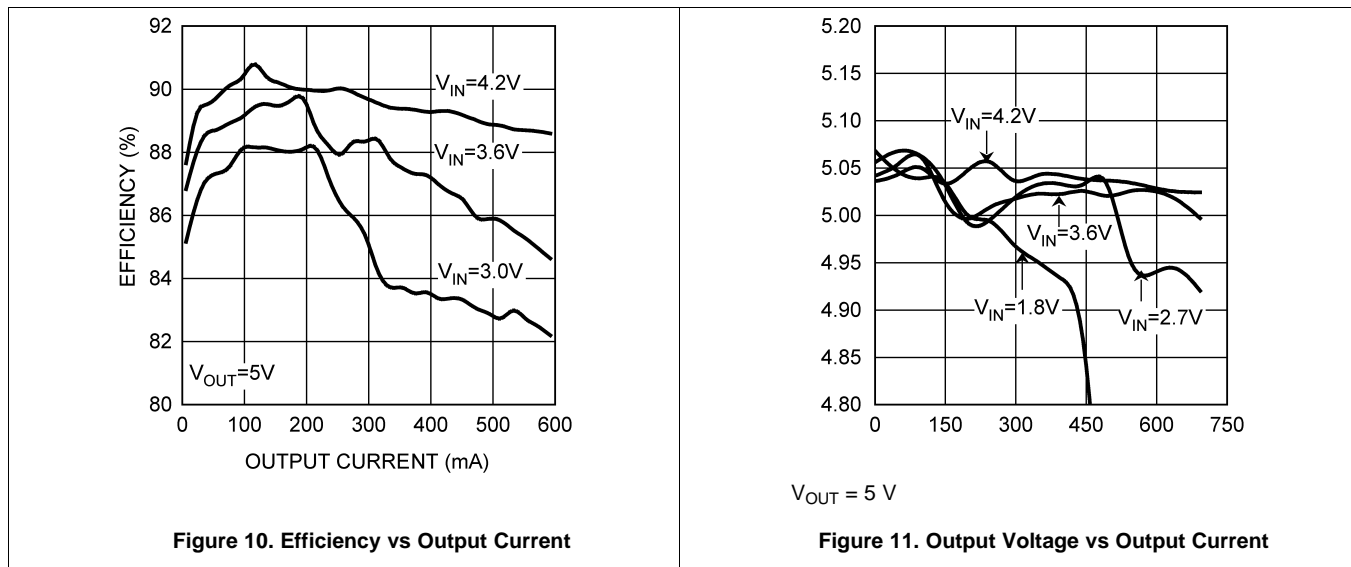

9 Power Supply Recommendations

The LM2623 can start up from voltages as low as 1.1 V. On start-up, the control circuitry switches the N-channel MOSFET continuously until the output reaches 3 V. After this output voltage is reached, the normal step-up regulator feedback and gated oscillator control scheme take over. Once the device is in regulation, it can operate down to below 0.8 V input, since the internal power for the IC can be boot-strapped from the output using the V_{DD} pin.

10 Layout

10.1 Layout Guidelines

The example layouts below follow proper layout guidelines and should be used as a guide for laying out the LM2623 circuit. The LM2623 inductive boost converter sees a high switched voltage at the SW pin, and a step current through the Schottky diode and output capacitor each switching cycle. The high switching voltage can create interference into nearby nodes due to electric field coupling ($I = C \times dV/dt$). The large step current through the diode and the output capacitor can cause a large voltage spike at the SW and BOOST pins due to parasitic inductance in the step current conducting path ($V = L \times di/dt$). Board layout guidelines are geared towards minimizing this electric field coupling and conducted noise.

[Boost Output Capacitor Placement](#), [Schottky Diode Placement](#), and [Boost Input / \$V_{DD}\$ Capacitor Placement](#) detail the main (layout sensitive) areas of the LM2623 inductive boost converter in order of decreasing importance:

10.1.1 Boost Output Capacitor Placement

Because the output capacitor is in the path of the inductor current discharge path, it will see a high-current step from 0 to IPEAK each time the switch turns off and the Schottky diode turns on. Any inductance along this series path from the diodes cathode, through COUT, and back into the LM2623 GND pin will contribute to voltage spikes at SW. These spikes can potentially over-voltage the SW and BOOST pins, or feed through to GND. To avoid this, COUT+ must be connected as close as possible to the cathode of the Schottky diode, and COUT- must be connected as close as possible to the LM2623 GND bumps. The best placement for COUT is on the same layer as the LM2623 to avoid any vias that can add excessive series inductance.

10.1.2 Schottky Diode Placement

In the LM2623 device boost circuit the Schottky diode is in the path of the inductor current discharge. As a result the Schottky diode sees a high-current step from 0 to IPEAK each time the switch turns off, and the diode turns on. Any inductance in series with the diode will cause a voltage spike at SW. This can potentially over-voltage the SW pin, or feed through to VOUT and through the output capacitor, into GND. Connecting the anode of the diode as close as possible to the SW pin, and connecting the cathode of the diode as close as possible to COUT+, will reduce the inductance (LP_{-}) and minimize these voltage spikes.

10.1.3 Boost Input / V_{DD} Capacitor Placement

The LM2623 input capacitor filters the inductor current ripple and the internal MOSFET driver currents. The inductor current ripple can add input voltage ripple due to any series resistance in the input power path. The MOSFET driver currents can add voltage spikes on the input due to the inductance in series with the V_{IN}/V_{DD} and the input capacitor. Close placement of the input capacitor to the V_{DD} pin and to the GND pin is critical since any series inductance between V_{IN}/V_{DD} and CIN+ or CIN- and GND can create voltage spikes that could appear on the V_{IN}/V_{DD} supply line and GND.

10.2 Layout Example

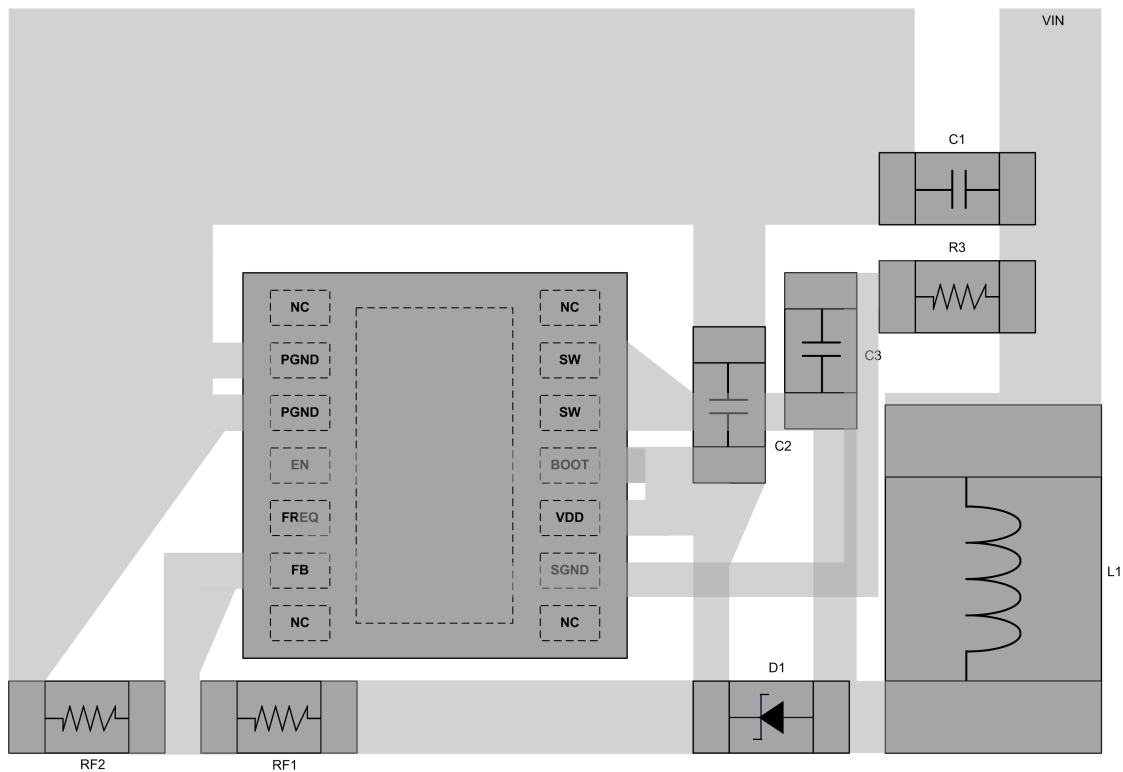

10.3 WSON Package Devices

The LM2623 is offered in the 14-lead WSON surface mount package to allow for increased power dissipation compared to the VSSOP-8. For details of the thermal performance as well as mounting and soldering specifications, refer to [Application Note AN-1187 Leadless Leadframe Package \(LLP\) \(SNOA401\)](#).

11 Device And Documentation Support

11.1 Device Support

11.1.1 Third-Party Products Disclaimer

TI'S PUBLICATION OF INFORMATION REGARDING THIRD-PARTY PRODUCTS OR SERVICES DOES NOT CONSTITUTE AN ENDORSEMENT REGARDING THE SUITABILITY OF SUCH PRODUCTS OR SERVICES OR A WARRANTY, REPRESENTATION OR ENDORSEMENT OF SUCH PRODUCTS OR SERVICES, EITHER ALONE OR IN COMBINATION WITH ANY TI PRODUCT OR SERVICE.

11.2 Documentation Support

11.2.1 Related Documentation

For related documentation, see the following:

[Application Note AN-1187 Leadless Leadframe Package \(LLP\)](#)

11.3 Receiving Notification of Documentation Updates

To receive notification of documentation updates, navigate to the device product folder on ti.com. In the upper right corner, click on *Alert me* to register and receive a weekly digest of any product information that has changed. For change details, review the revision history included in any revised document.

11.4 Community Resources

The following links connect to TI community resources. Linked contents are provided "AS IS" by the respective contributors. They do not constitute TI specifications and do not necessarily reflect TI's views; see TI's [Terms of Use](#).

TI E2E™ Online Community *TI's Engineer-to-Engineer (E2E) Community*. Created to foster collaboration among engineers. At e2e.ti.com, you can ask questions, share knowledge, explore ideas and help solve problems with fellow engineers.

Design Support *TI's Design Support* Quickly find helpful E2E forums along with design support tools and contact information for technical support.

11.5 Trademarks

E2E is a trademark of Texas Instruments.
All other trademarks are the property of their respective owners.

11.6 Electrostatic Discharge Caution



These devices have limited built-in ESD protection. The leads should be shorted together or the device placed in conductive foam during storage or handling to prevent electrostatic damage to the MOS gates.

11.7 Glossary

[SLYZ022](#) — *TI Glossary*.

This glossary lists and explains terms, acronyms, and definitions.

12 Mechanical, Packaging, And Orderable Information

The following pages include mechanical, packaging, and orderable information. This information is the most current data available for the designated devices. This data is subject to change without notice and revision of this document. For browser-based versions of this data sheet, refer to the left-hand navigation.

PACKAGING INFORMATION

Orderable Device	Status (1)	Package Type	Package Drawing	Pins	Package Qty	Eco Plan (2)	Lead finish/ Ball material (6)	MSL Peak Temp (3)	Op Temp (°C)	Device Marking (4/5)	Samples
LM2623ALD/NOPB	ACTIVE	WSON	NHE	14	1000	RoHS & Green	SN	Level-3-260C-168 HR	-40 to 85	2623A	Samples
LM2623AMM	LIFEBUY	VSSOP	DGK	8	1000	Non-RoHS & Green	Call TI	Level-1-260C-UNLIM	-40 to 85	S46A	
LM2623AMM/NOPB	ACTIVE	VSSOP	DGK	8	1000	RoHS & Green	SN	Level-1-260C-UNLIM	-40 to 85	S46A	Samples
LM2623AMMX/NOPB	ACTIVE	VSSOP	DGK	8	3500	RoHS & Green	SN	Level-1-260C-UNLIM	-40 to 85	S46A	Samples
LM2623LD/NOPB	ACTIVE	WSON	NHE	14	1000	RoHS & Green	SN	Level-3-260C-168 HR	-40 to 85	2623AB	Samples
LM2623LDX/NOPB	ACTIVE	WSON	NHE	14	4500	RoHS & Green	SN	Level-3-260C-168 HR	-40 to 85	2623AB	Samples
LM2623MM/NOPB	ACTIVE	VSSOP	DGK	8	1000	RoHS & Green	SN	Level-1-260C-UNLIM	-40 to 85	S46B	Samples
LM2623MMX/NOPB	ACTIVE	VSSOP	DGK	8	3500	RoHS & Green	SN	Level-1-260C-UNLIM	-40 to 85	S46B	Samples

(1) The marketing status values are defined as follows:

ACTIVE: Product device recommended for new designs.

LIFEBUY: TI has announced that the device will be discontinued, and a lifetime-buy period is in effect.

NRND: Not recommended for new designs. Device is in production to support existing customers, but TI does not recommend using this part in a new design.

PREVIEW: Device has been announced but is not in production. Samples may or may not be available.

OBSOLETE: TI has discontinued the production of the device.

(2) **RoHS:** TI defines "RoHS" to mean semiconductor products that are compliant with the current EU RoHS requirements for all 10 RoHS substances, including the requirement that RoHS substance do not exceed 0.1% by weight in homogeneous materials. Where designed to be soldered at high temperatures, "RoHS" products are suitable for use in specified lead-free processes. TI may reference these types of products as "Pb-Free".

RoHS Exempt: TI defines "RoHS Exempt" to mean products that contain lead but are compliant with EU RoHS pursuant to a specific EU RoHS exemption.

Green: TI defines "Green" to mean the content of Chlorine (Cl) and Bromine (Br) based flame retardants meet JS709B low halogen requirements of <=1000ppm threshold. Antimony trioxide based flame retardants must also meet the <=1000ppm threshold requirement.

(3) MSL, Peak Temp. - The Moisture Sensitivity Level rating according to the JEDEC industry standard classifications, and peak solder temperature.

(4) There may be additional marking, which relates to the logo, the lot trace code information, or the environmental category on the device.

(5) Multiple Device Markings will be inside parentheses. Only one Device Marking contained in parentheses and separated by a "~" will appear on a device. If a line is indented then it is a continuation of the previous line and the two combined represent the entire Device Marking for that device.

⁽⁶⁾ Lead finish/Ball material - Orderable Devices may have multiple material finish options. Finish options are separated by a vertical ruled line. Lead finish/Ball material values may wrap to two lines if the finish value exceeds the maximum column width.

Important Information and Disclaimer:The information provided on this page represents TI's knowledge and belief as of the date that it is provided. TI bases its knowledge and belief on information provided by third parties, and makes no representation or warranty as to the accuracy of such information. Efforts are underway to better integrate information from third parties. TI has taken and continues to take reasonable steps to provide representative and accurate information but may not have conducted destructive testing or chemical analysis on incoming materials and chemicals. TI and TI suppliers consider certain information to be proprietary, and thus CAS numbers and other limited information may not be available for release.

In no event shall TI's liability arising out of such information exceed the total purchase price of the TI part(s) at issue in this document sold by TI to Customer on an annual basis.

OTHER QUALIFIED VERSIONS OF LM2623 :

- Automotive : [LM2623-Q1](#)

NOTE: Qualified Version Definitions:

- Automotive - Q100 devices qualified for high-reliability automotive applications targeting zero defects

TAPE AND REEL INFORMATION

QUADRANT ASSIGNMENTS FOR PIN 1 ORIENTATION IN TAPE

*All dimensions are nominal

Device	Package Type	Package Drawing	Pins	SPQ	Reel Diameter (mm)	Reel Width W1 (mm)	A0 (mm)	B0 (mm)	K0 (mm)	P1 (mm)	W (mm)	Pin1 Quadrant
LM2623ALD/NOPB	WSON	NHE	14	1000	178.0	12.4	4.3	4.3	1.3	8.0	12.0	Q1
LM2623AMM	VSSOP	DGK	8	1000	178.0	12.4	5.3	3.4	1.4	8.0	12.0	Q1
LM2623AMM/NOPB	VSSOP	DGK	8	1000	178.0	12.4	5.3	3.4	1.4	8.0	12.0	Q1
LM2623AMMX/NOPB	VSSOP	DGK	8	3500	330.0	12.4	5.3	3.4	1.4	8.0	12.0	Q1
LM2623LD/NOPB	WSON	NHE	14	1000	178.0	12.4	4.3	4.3	1.3	8.0	12.0	Q1
LM2623LDX/NOPB	WSON	NHE	14	4500	330.0	12.4	4.3	4.3	1.3	8.0	12.0	Q1
LM2623MM/NOPB	VSSOP	DGK	8	1000	178.0	12.4	5.3	3.4	1.4	8.0	12.0	Q1
LM2623MMX/NOPB	VSSOP	DGK	8	3500	330.0	12.4	5.3	3.4	1.4	8.0	12.0	Q1

TAPE AND REEL BOX DIMENSIONS

*All dimensions are nominal

Device	Package Type	Package Drawing	Pins	SPQ	Length (mm)	Width (mm)	Height (mm)
LM2623ALD/NOPB	WSON	NHE	14	1000	208.0	191.0	35.0
LM2623AMM	VSSOP	DGK	8	1000	210.0	185.0	35.0
LM2623AMM/NOPB	VSSOP	DGK	8	1000	210.0	185.0	35.0
LM2623AMMX/NOPB	VSSOP	DGK	8	3500	367.0	367.0	35.0
LM2623LD/NOPB	WSON	NHE	14	1000	208.0	191.0	35.0
LM2623LDX/NOPB	WSON	NHE	14	4500	356.0	356.0	36.0
LM2623MM/NOPB	VSSOP	DGK	8	1000	210.0	185.0	35.0
LM2623MMX/NOPB	VSSOP	DGK	8	3500	367.0	367.0	35.0

DGK0008A

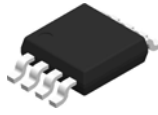

PACKAGE OUTLINE

VSSOP - 1.1 mm max height

SMALL OUTLINE PACKAGE

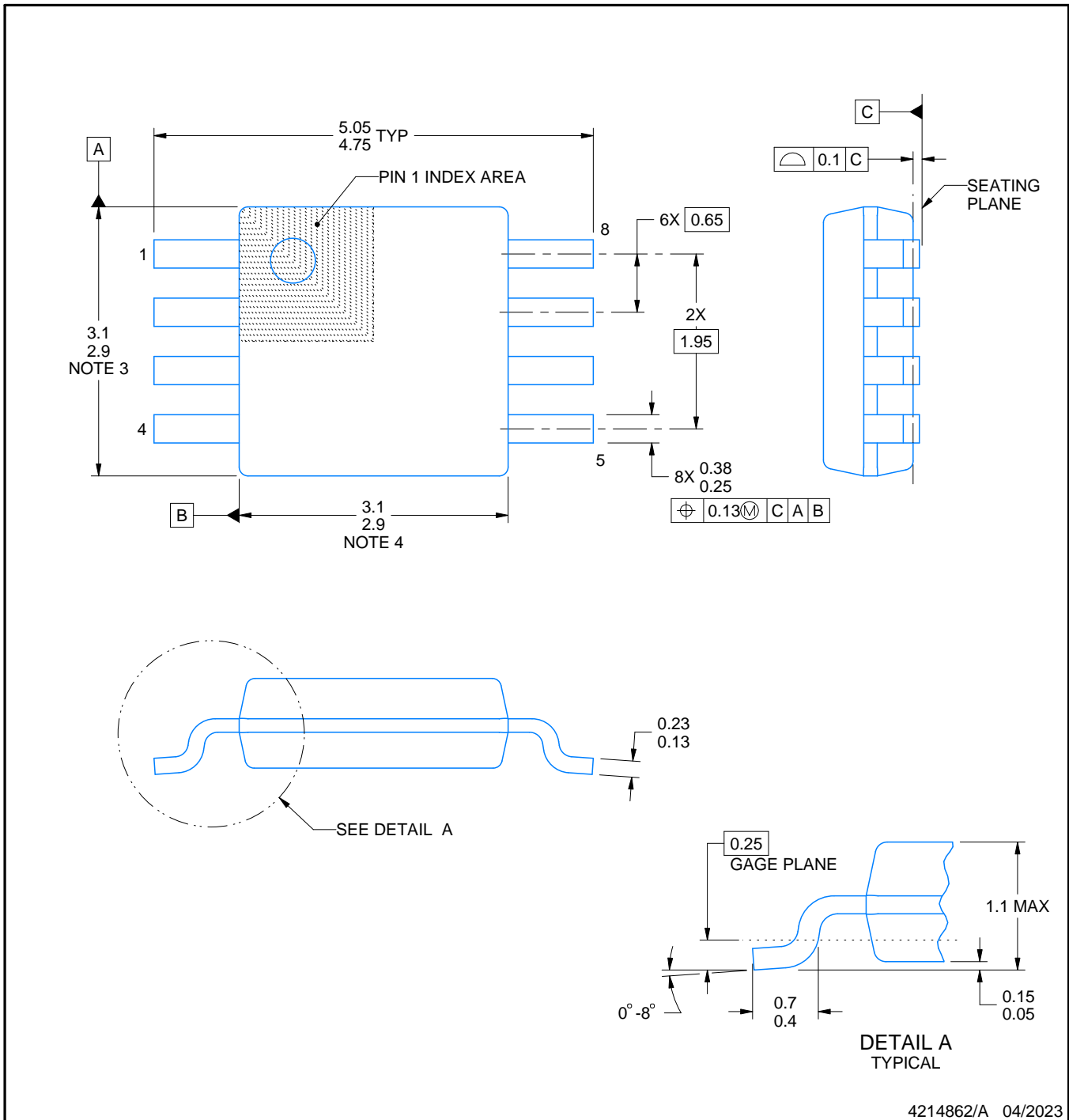

NOTES:

PowerPAD is a trademark of Texas Instruments.

1. All linear dimensions are in millimeters. Any dimensions in parenthesis are for reference only. Dimensioning and tolerancing per ASME Y14.5M.
2. This drawing is subject to change without notice.
3. This dimension does not include mold flash, protrusions, or gate burrs. Mold flash, protrusions, or gate burrs shall not exceed 0.15 mm per side.
4. This dimension does not include interlead flash. Interlead flash shall not exceed 0.25 mm per side.
5. Reference JEDEC registration MO-187.

EXAMPLE BOARD LAYOUT

DGK0008A

™ VSSOP - 1.1 mm max height

SMALL OUTLINE PACKAGE

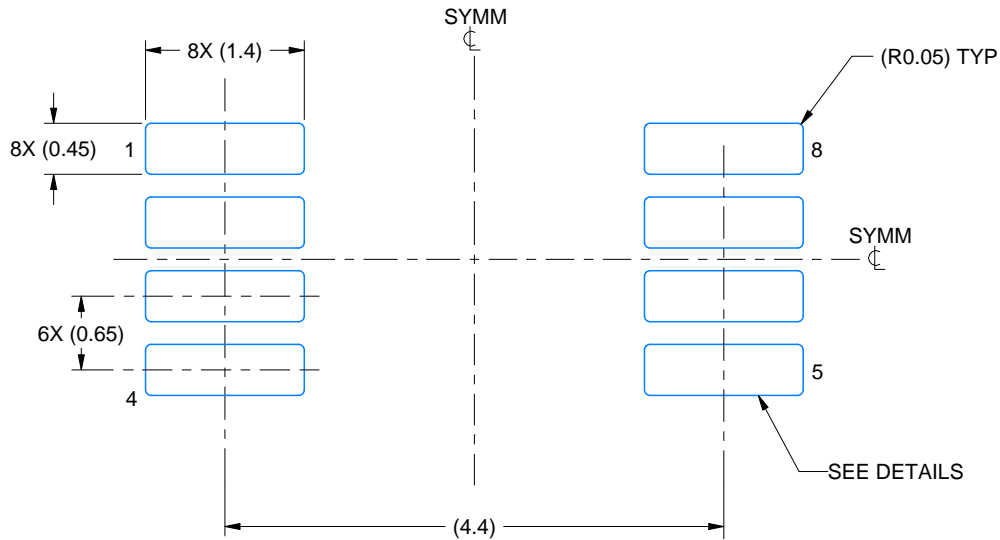

LAND PATTERN EXAMPLE
EXPOSED METAL SHOWN
SCALE: 15X

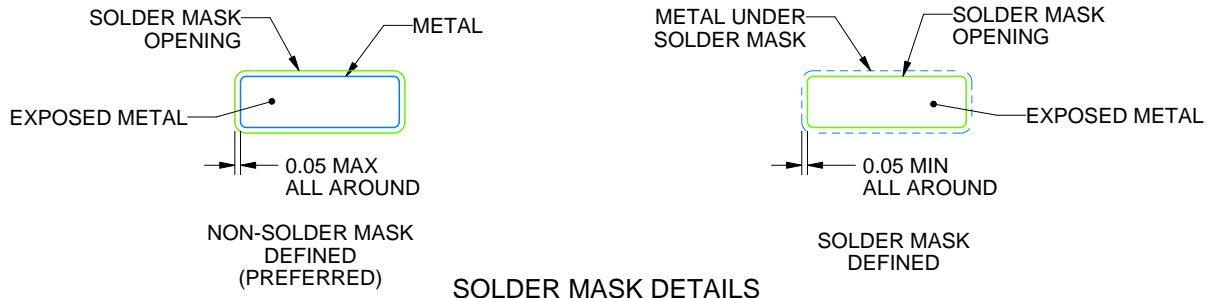

SOLDER MASK DETAILS

4214862/A 04/2023

NOTES: (continued)

6. Publication IPC-7351 may have alternate designs.
7. Solder mask tolerances between and around signal pads can vary based on board fabrication site.
8. Vias are optional depending on application, refer to device data sheet. If any vias are implemented, refer to their locations shown on this view. It is recommended that vias under paste be filled, plugged or tented.
9. Size of metal pad may vary due to creepage requirement.

EXAMPLE STENCIL DESIGN

DGK0008A

™ VSSOP - 1.1 mm max height

SMALL OUTLINE PACKAGE



SOLDER PASTE EXAMPLE
SCALE: 15X

4214862/A 04/2023

NOTES: (continued)

11. Laser cutting apertures with trapezoidal walls and rounded corners may offer better paste release. IPC-7525 may have alternate design recommendations.
12. Board assembly site may have different recommendations for stencil design.

NHE0014A

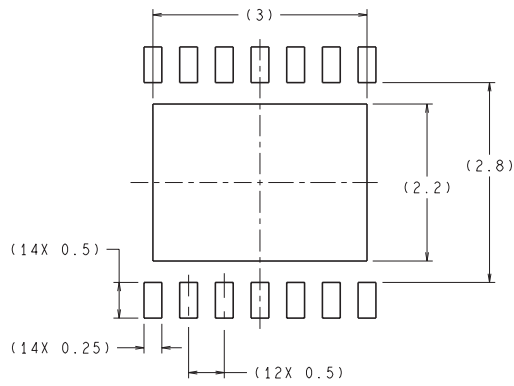

RECOMMENDED LAND PATTERN
1:1 RATION WITH PKG SOLDER PADS

DIMENSIONS ARE IN MILLIMETERS

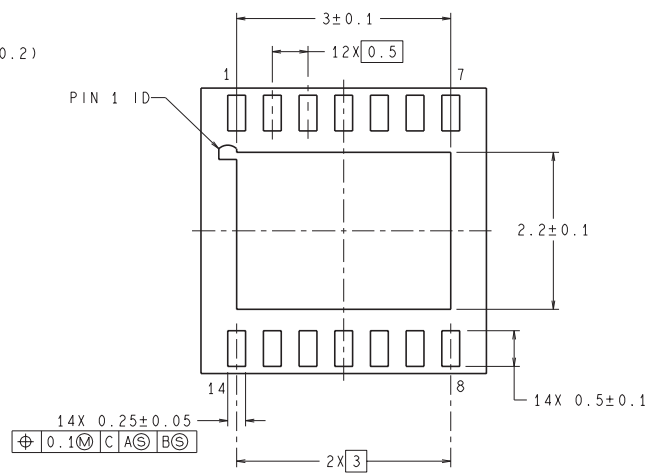
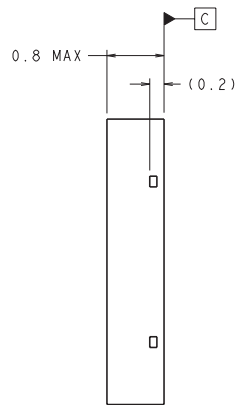
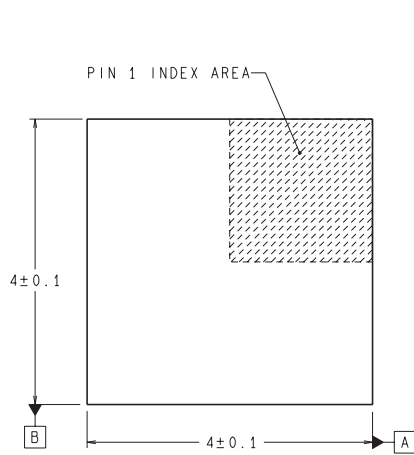

LDA14A (REV A)

IMPORTANT NOTICE AND DISCLAIMER

TI PROVIDES TECHNICAL AND RELIABILITY DATA (INCLUDING DATA SHEETS), DESIGN RESOURCES (INCLUDING REFERENCE DESIGNS), APPLICATION OR OTHER DESIGN ADVICE, WEB TOOLS, SAFETY INFORMATION, AND OTHER RESOURCES "AS IS" AND WITH ALL FAULTS, AND DISCLAIMS ALL WARRANTIES, EXPRESS AND IMPLIED, INCLUDING WITHOUT LIMITATION ANY IMPLIED WARRANTIES OF MERCHANTABILITY, FITNESS FOR A PARTICULAR PURPOSE OR NON-INFRINGEMENT OF THIRD PARTY INTELLECTUAL PROPERTY RIGHTS.

These resources are intended for skilled developers designing with TI products. You are solely responsible for (1) selecting the appropriate TI products for your application, (2) designing, validating and testing your application, and (3) ensuring your application meets applicable standards, and any other safety, security, regulatory or other requirements.

These resources are subject to change without notice. TI grants you permission to use these resources only for development of an application that uses the TI products described in the resource. Other reproduction and display of these resources is prohibited. No license is granted to any other TI intellectual property right or to any third party intellectual property right. TI disclaims responsibility for, and you will fully indemnify TI and its representatives against, any claims, damages, costs, losses, and liabilities arising out of your use of these resources.

TI's products are provided subject to [TI's Terms of Sale](#) or other applicable terms available either on [ti.com](https://www.ti.com) or provided in conjunction with such TI products. TI's provision of these resources does not expand or otherwise alter TI's applicable warranties or warranty disclaimers for TI products.

TI objects to and rejects any additional or different terms you may have proposed.

Mailing Address: Texas Instruments, Post Office Box 655303, Dallas, Texas 75265
Copyright © 2024, Texas Instruments Incorporated

Looking for pricing, stock, or lifecycle information?

Click below to explore more details on WIN SOURCE:

 [View LM2623AMMX/NOPB on WIN SOURCE](#)

 [Texas Instruments](#) Information

Optimize Your Supply Chain with WIN SOURCE Solutions

-  Global Sourcing Solution
-  Obsolete Management
-  Cost Control Management
-  Shortage Management
-  Alternative Solution
-  Excess Inventory Management