



# THE DATASHEET OF BUL1203EFP





## BUL1203EFP

# HIGH VOLTAGE FAST-SWITCHING NPN POWER TRANSISTOR

- HIGH VOLTAGE CAPABILITY
- LOW SPREAD OF DYNAMIC PARAMETERS
- MINIMUM LOT-TO-LOT SPREAD FOR RELIABLE OPERATION
- VERY HIGH SWITCHING SPEED
- FULLY INSULATED PACKAGE (U.L. COMPLIANT) FOR EASY MOUNTING

### APPLICATIONS

- ELECTRONIC BALLASTS FOR FLUORESCENT LIGHTING (277 V HALF BRIDGE AND 120 V PUSH-PULL TOPOLOGIES)

### DESCRIPTION

The BUL1203EFP is a new device manufactured using Diffused Collector technology to enhance switching speeds and tight  $h_{FE}$  range while maintaining a wide RBSOA.

Thanks to his structure it has an intrinsic ruggedness which enables the transistor to withstand a high collector current level during Breakdown condition, without using the transil protection usually necessary in typical converters for lamp ballast.

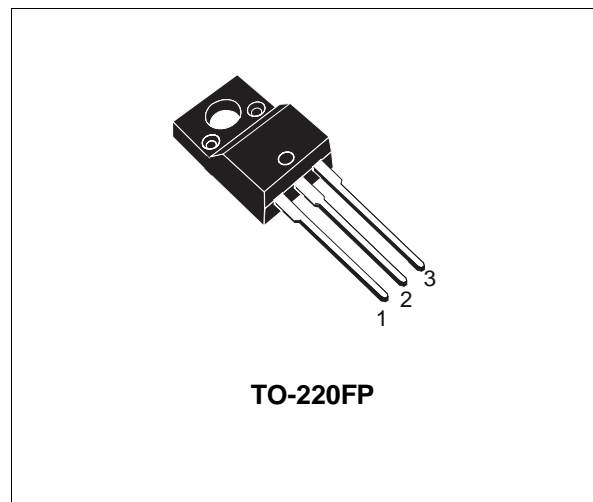

### INTERNAL SCHEMATIC DIAGRAM

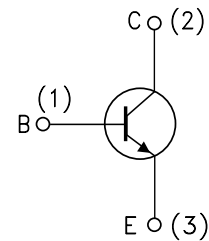

### ABSOLUTE MAXIMUM RATINGS

Symbol	Parameter	Value	Unit
$V_{CBO}$	Collector-Base Voltage ( $I_E = 0$ )	1200	V
$V_{CES}$	Collector-Emitter Voltage ( $V_{BE} = 0$ )	1200	V
$V_{CEO}$	Collector-Emitter Voltage ( $I_B = 0$ )	550	V
$V_{EBO}$	Emitter-Base Voltage ( $I_C = 0$ )	9	V
$I_C$	Collector Current	5	A
$I_{CM}$	Collector Peak Current ( $t_p < 5$ ms)	8	A
$I_B$	Base Current	2	A
$I_{BM}$	Base Peak Current ( $t_p < 5$ ms)	4	A
$P_{tot}$	Total Dissipation at $T_c = 25$ °C	36	W
$V_{isol}$	Insulation Withstand Voltage (RMS) from All Three Leads to External Heatsink	1500	V
$T_{stg}$	Storage Temperature	-65 to 150	°C
$T_j$	Max. Operating Junction Temperature	150	°C

# BUL1203EFP

## THERMAL DATA

R <sub>thj-case</sub>	Thermal Resistance Junction-case	Max	3.47	°C/W
R <sub>thj-amb</sub>	Thermal Resistance Junction-ambient	Max	62.5	°C/W

## ELECTRICAL CHARACTERISTICS (T<sub>case</sub> = 25 °C unless otherwise specified)

Symbol	Parameter	Test Conditions	Min.	Typ.	Max.	Unit
I <sub>CES</sub>	Collector Cut-off Current (V <sub>BE</sub> = 0)	V <sub>CE</sub> = 1200 V			100	μA
I <sub>CEO</sub>	Collector Cut-off Current (I <sub>B</sub> = 0)	V <sub>CE</sub> = 550 V			100	μA
V <sub>CEO(sus)*</sub>	Collector-Emitter Sustaining Voltage (I <sub>B</sub> = 0)	I <sub>C</sub> = 100 mA    L = 25 mH	550			V
V <sub>EBO</sub>	Emitter-Base Voltage (I <sub>C</sub> = 0)	I <sub>E</sub> = 10 mA	9			V
V <sub>CE(sat)*</sub>	Collector-Emitter Saturation Voltage	I <sub>C</sub> = 1 A    I <sub>B</sub> = 0.2 A I <sub>C</sub> = 2 A    I <sub>B</sub> = 0.4 A I <sub>C</sub> = 3 A    I <sub>B</sub> = 1 A			0.5 0.7 1.5	V V V
V <sub>BE(sat)*</sub>	Base-Emitter Saturation Voltage	I <sub>C</sub> = 2 A    I <sub>B</sub> = 0.4 A I <sub>C</sub> = 3 A    I <sub>B</sub> = 1 A			1.5 1.5	V V
h <sub>FE*</sub>	DC Current Gain	I <sub>C</sub> = 1 mA    V <sub>CE</sub> = 5 V I <sub>C</sub> = 10 mA    V <sub>CE</sub> = 5 V I <sub>C</sub> = 0.8 A    V <sub>CE</sub> = 3 V I <sub>C</sub> = 2 A    V <sub>CE</sub> = 5 V	10 10 14 9		32 28	
t <sub>on</sub> t <sub>s</sub> t <sub>f</sub>	RESISTIVE LOAD Turn-on Time Storage Time Fall Time	I <sub>C</sub> = 2 A    I <sub>B1</sub> = 0.4 A I <sub>B2</sub> = -0.8 A    tp = 30 μs V <sub>CC</sub> = 150 V    (see figure 2)		2.5 0.2	0.5 3.0 0.3	μs μs μs
E <sub>ar</sub>	Repetitive Avalanche Energy	L = 2 mH    C = 1.8 nF V <sub>CC</sub> = 50 V    V <sub>BE</sub> = -5 V (see figure 3)	6			mJ

\* Pulsed: Pulse duration = 300 μs, duty cycle 1.5 %

## Safe Operating Area

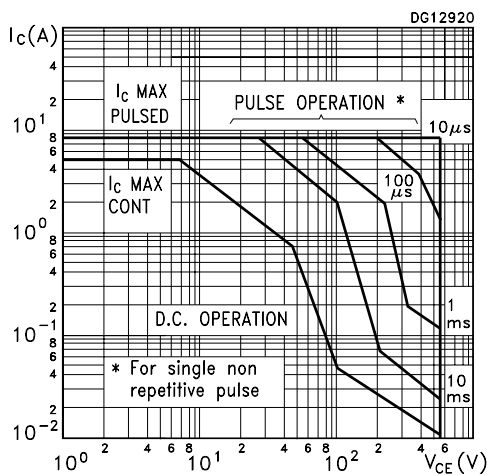

## Derating Curve

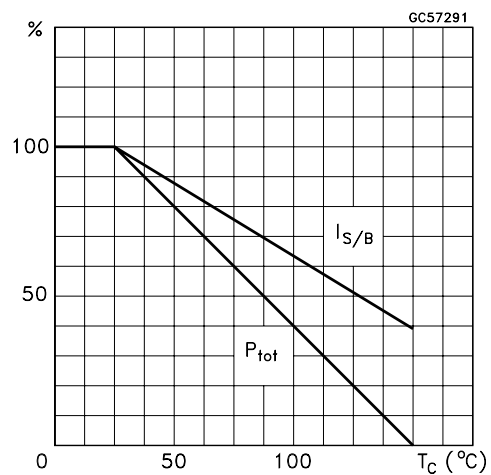

DC Current Gain

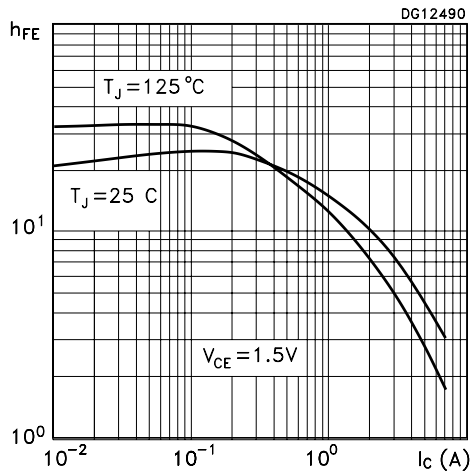

DC Current Gain

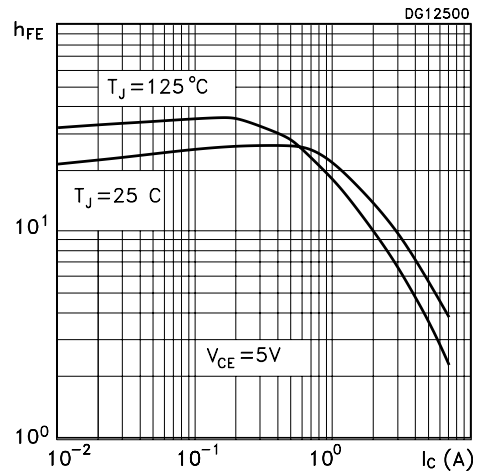

Collector-Emitter Saturation Voltage

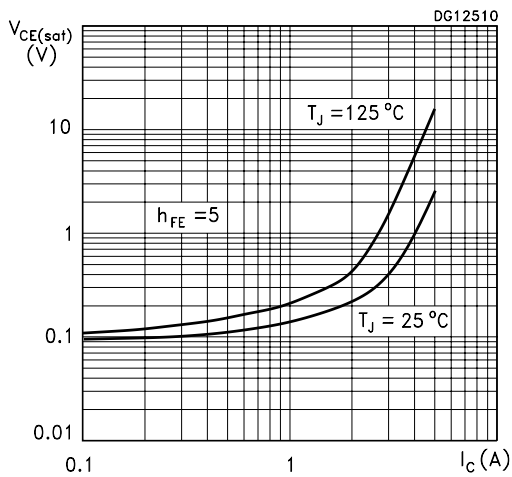

Base-Emitter Saturation Voltage

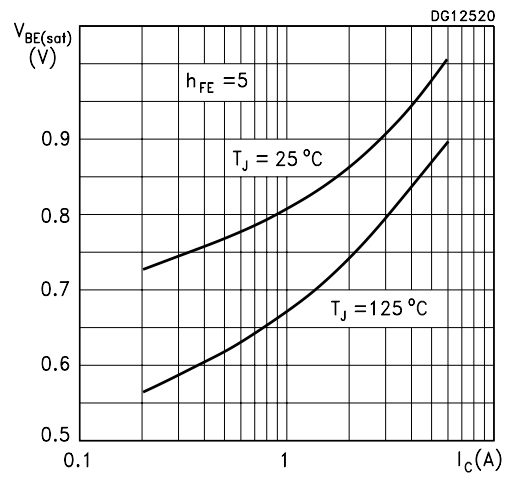

Inductive Load Storage Time

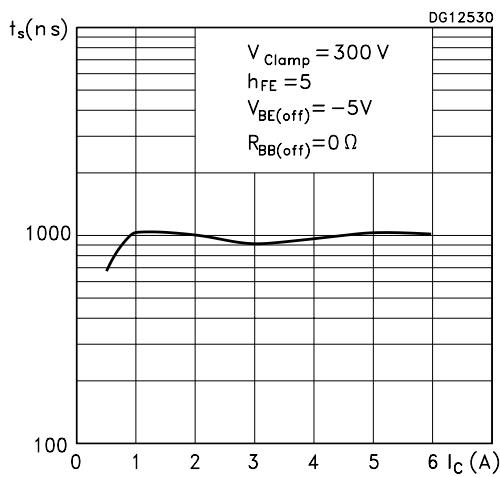

Inductive Load Fall Time

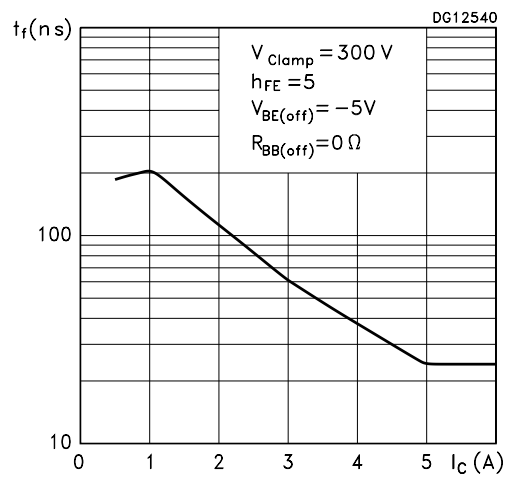

Reverse Biased Safe Operating Area

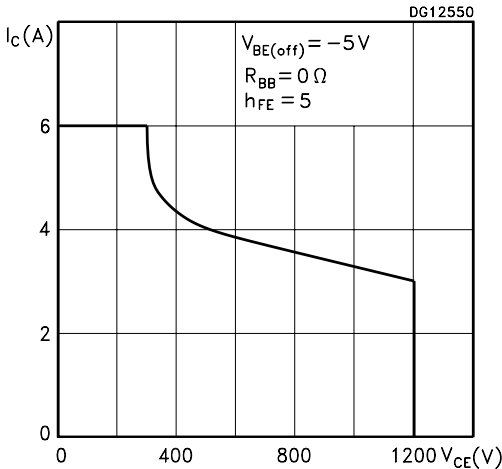

Figure 1: Inductive Load Switching Test Circuit

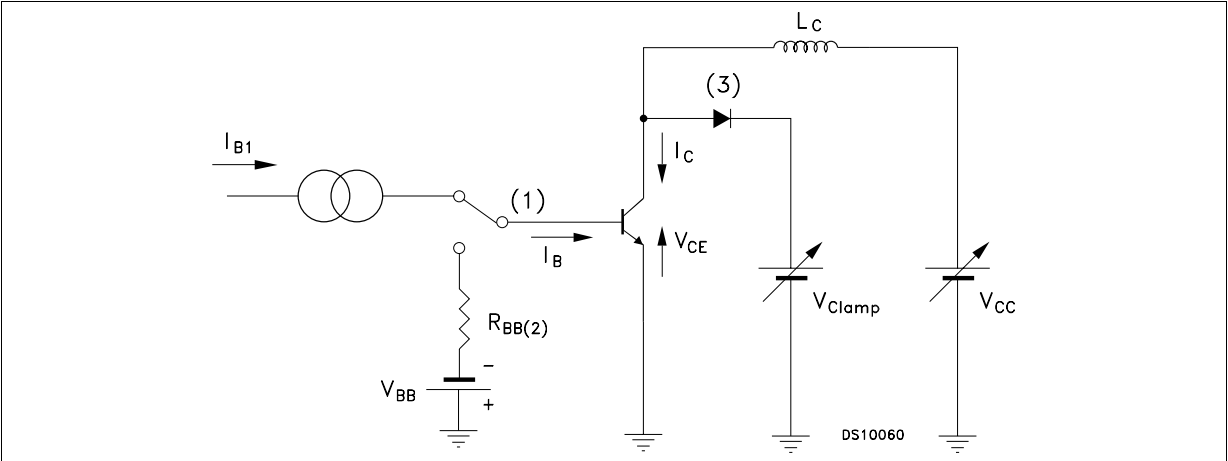

Figure 2: Resistive Load Switching Test Circuit

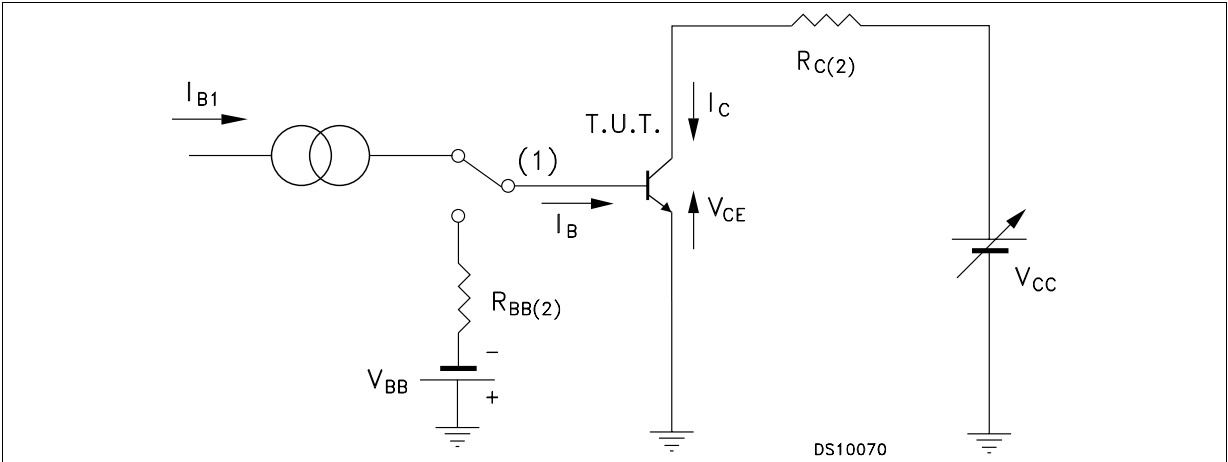
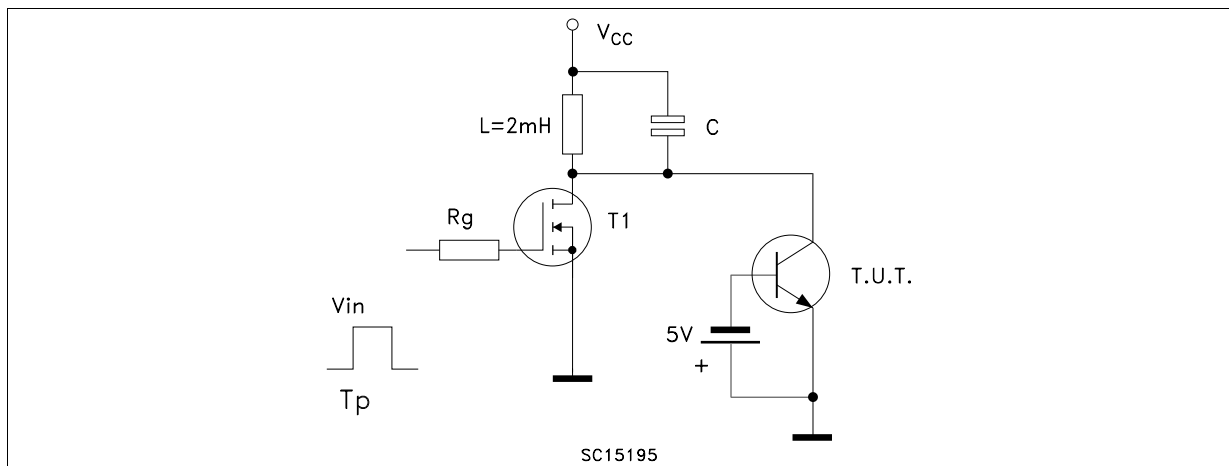
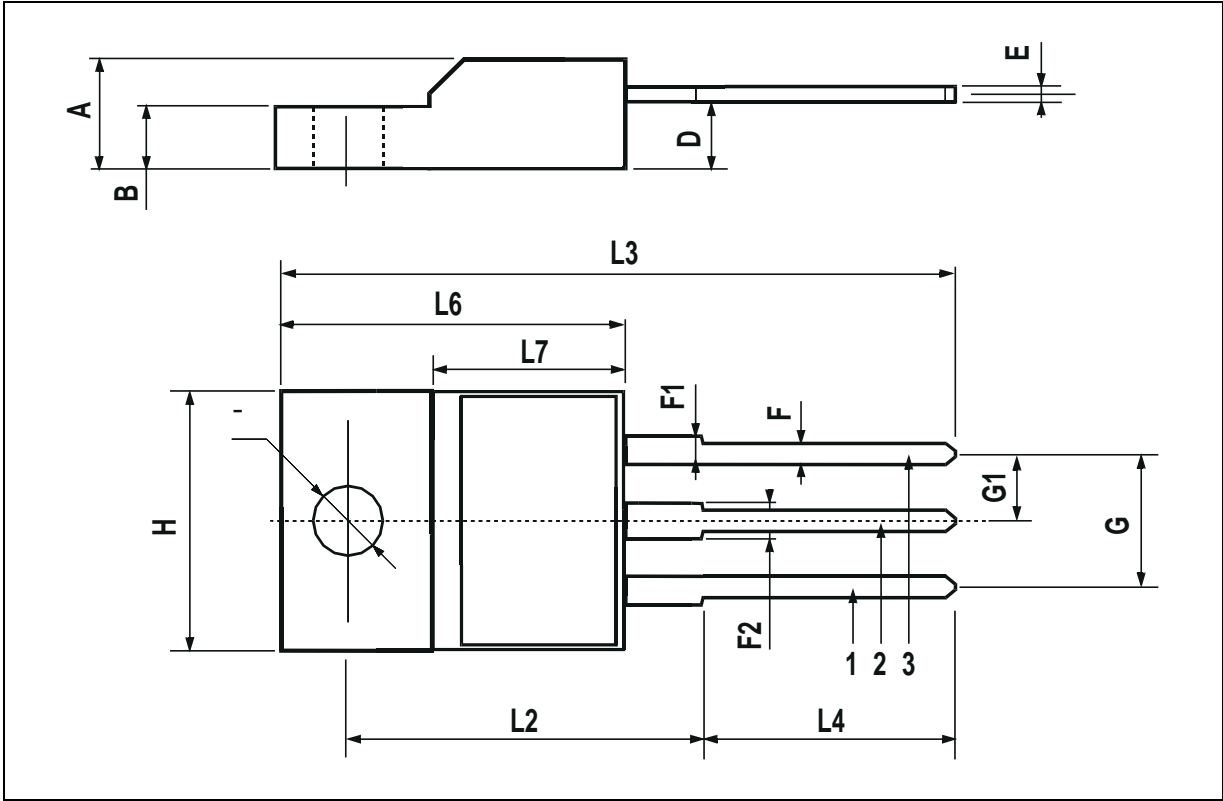

Figure 3: Energy Rating Test Circuit



**TO-220FP MECHANICAL DATA**

DIM.	mm			inch		
	MIN.	TYP.	MAX.	MIN.	TYP.	MAX.
A	4.4		4.6	0.173		0.181
B	2.5		2.7	0.098		0.106
D	2.5		2.75	0.098		0.108
E	0.45		0.7	0.017		0.027
F	0.75		1	0.030		0.039
F1	1.15		1.7	0.045		0.067
F2	1.15		1.7	0.045		0.067
G	4.95		5.2	0.195		0.204
G1	2.4		2.7	0.094		0.106
H	10		10.4	0.393		0.409
L2		16			0.630	
L3	28.6		30.6	1.126		1.204
L4	9.8		10.6	0.385		0.417
L6	15.9		16.4	0.626		0.645
L7	9		9.3	0.354		0.366
Ø	3		3.2	0.118		0.126



Information furnished is believed to be accurate and reliable. However, STMicroelectronics assumes no responsibility for the consequences of use of such information nor for any infringement of patents or other rights of third parties which may result from its use. No license is granted by implication or otherwise under any patent or patent rights of STMicroelectronics. Specification mentioned in this publication are subject to change without notice. This publication supersedes and replaces all information previously supplied. STMicroelectronics products are not authorized for use as critical components in life support devices or systems without express written approval of STMicroelectronics.

The ST logo is a trademark of STMicroelectronics.

All other names are the property of their respective owners.

© 2003 STMicroelectronics – All Rights reserved



STMicroelectronics GROUP OF COMPANIES

Australia - Belgium - Brazil - Canada - China - Czech Republic - Finland - France - Germany - Hong Kong - India - Israel - Italy - Japan - Malaysia - Malta - Morocco - Singapore - Spain - Sweden - Switzerland - United Kingdom - United States.

<http://www.st.com>

## Looking for pricing, stock, or lifecycle information?

Click below to explore more details on WIN SOURCE:

-  [View BUL1203EFP](#) on WIN SOURCE
-  [STMicroelectronics](#) Information

## Optimize Your Supply Chain with WIN SOURCE Solutions

-  Global Sourcing Solution
-  Obsolete Management
-  Cost Control Management
-  Shortage Management
-  Alternative Solution
-  Excess Inventory Management