



**THE DATASHEET OF
NESG2030M04-A**



NPN SiGe HIGH FREQUENCY TRANSISTOR

FEATURES

- **SiGe TECHNOLOGY:**
f_T = 60 GHz Process
- **LOW NOISE FIGURE:**
NF = 0.9 dBm at 2 GHz
- **HIGH MAXIMUM STABLE GAIN:**
MSG = 20 dB at 2 GHz
- **NEW LOW PROFILE M04 PACKAGE:**
SOT-343 footprint, with a height of only 0.59 mm
Flat lead style for better RF performance

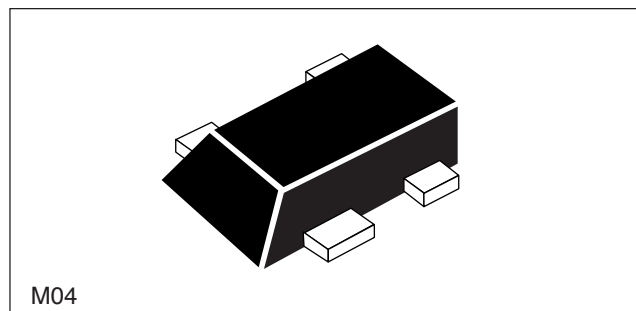

DESCRIPTION

NEC's NESG2030M04 is fabricated using NEC's state-of-the-art SiGe, wafer process. With a typical transition frequency of 60 GHz the NESG2030M04 is usable in applications from 100 MHz to over 10 GHz. Maximum DC current input of 35 mA provides a device with a usable current range of 250 μA to 25 mA. The NESG2030M04 provides excellent low voltage/low current performance.

NEC's new low profile/flat lead style "M04" package is ideal for today's portable wireless applications. The NESG2030M04 is an ideal choice for LNA and oscillator requirements in all mobile communication systems.

ELECTRICAL CHARACTERISTICS (T_A = 25°C)

		PART NUMBER EIAJ ¹ REGISTERED NUMBER PACKAGE OUTLINE	NESG2030M04 2SC5761 M04			
SYMBOLS		PARAMETERS AND CONDITIONS	UNITS	MIN	TYP	MAX
DC	I _{CBO}	Collector Cutoff Current at V _{CB} = 5V, I _E = 0	nA			200
	I _{EBO}	Emitter Cutoff Current at V _{EB} = 0.5 V, I _C = 0	nA			200
	h _{FE}	DC Current Gain ² at V _{CE} = 2 V, I _C = 5 mA		200		400
RF	C _{re}	Reverse Transfer Capacitance ³ at V _{CB} = 2 V, I _E = 0 mA, f = 1 GHz	pF		0.17	0.22
	NF	Noise Figure at V _{CE} = 2 V, I _C = 5 mA, f = 2 GHz, Z _{IN} = Z _{OPT}	dB		0.9	1.1
	G _a	Associated Gain at V _{CE} = 2 V, I _C = 5 mA, f = 2 GHz, Z _S = Z _{OPT}	GHz		16	
	MSG	Maximum Stable Gain ⁴ at V _{CE} = 2 V, I _C = 20 mA, f = 2 GHz	dB	18	20	
	I _{S21EI} ²	Insertion Power Gain at V _{CE} = 2 V, I _C = 20 mA, f = 2 GHz	dB	16	18	
	P _{1dB}	Output Power at 1 dB compression point V _{CE} = 2 V, I _C = 20 mA, f = 2 GHz	dBm		12	
	OIP ₃	Third Order Intercept Point, V _{CE} = 2 V, I _C = 20 mA, f = 2 GHz	dBm		22	

Notes:

1. Electronic Industrial Association of Japan.
2. Pulsed measurement, pulse width ≤ 350 μs, duty cycle ≤ 2 %.
3. Collector to base capacitance is measured by capacitance meter (automatic balance bridge method) when emitter pin is connected to the guard pin.
4. $MSG = \left| \frac{S_{21}}{S_{12}} \right|$

The information in this document is subject to change without notice. Before using this document, please confirm that this is the latest version.

ABSOLUTE MAXIMUM RATINGS¹ (T_A = 25°C)

SYMBOLS	PARAMETERS	UNITS	RATINGS
V _{CB0}	Collector to Base Voltage	V	8.0
V _{CE0}	Collector to Emitter Voltage	V	2.3
V _{EB0}	Emitter to Base Voltage	V	1.2
I _C	Collector Current	mA	35
P _T ²	Total Power Dissipation	mW	80
T _J	Junction Temperature	°C	150
T _{STG}	Storage Temperature	°C	-65 to +150

Note:

1. Operation in excess of any one of these parameters may result in permanent damage.
2. Mounted on 1.08 cm² • 1.0 mm (t) glass epoxy substrate

THERMAL RESISTANCE

SYMBOLS	PARAMETERS	UNITS	RATINGS
R _{th j-c}	Junction to Case Resistance	°C/W	150

ORDERING INFORMATION (Solder Contains Lead)

PART NUMBER	QUANTITY
NESG2030M04	50 pcs(non reel)
NESG2030M04-T2	3 kpcs/reel

ORDERING INFORMATION (Pb-Free)

PART NUMBER	QUANTITY
NESG2030M04-A	50 pcs(non reel)
NESG2030M04-T2-A	3 kpcs/reel

TYPICAL PERFORMANCE CURVES (T_A = 25°C)

COLLECTOR CURRENT vs. COLLECTOR TO EMITTER VOLTAGE

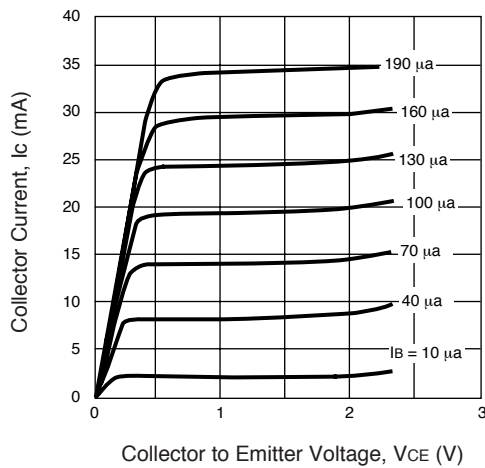

DC CURRENT GAIN vs. COLLECTOR CURRENT

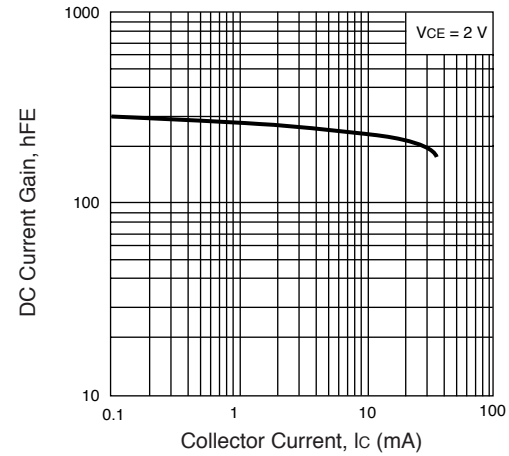

GAIN BANDWIDTH vs. COLLECTOR CURRENT

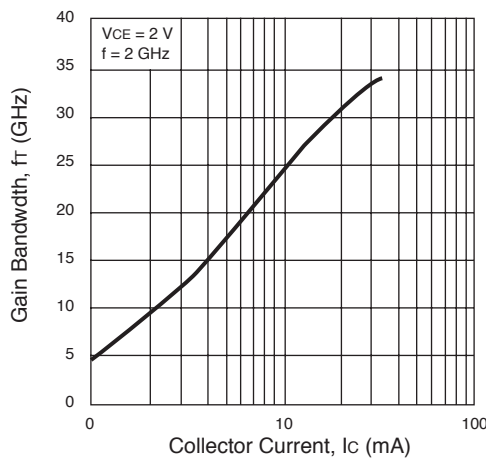

INSERTION POWER GAIN vs. FREQUENCY

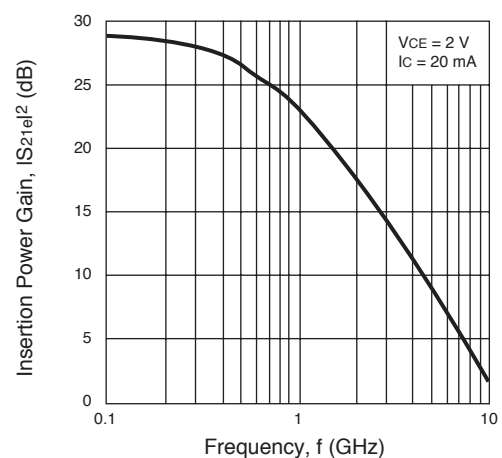

TYPICAL PERFORMANCE CURVES (TA = 25°C)

MAXIMUM STABLE GAIN,
INSERTION POWER GAIN
vs. COLLECTOR CURRENT

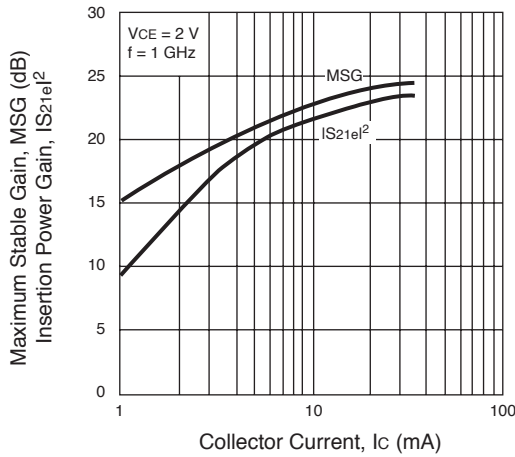

MAXIMUM STABLE GAIN,
INSERTION POWER GAIN
vs. COLLECTOR CURRENT

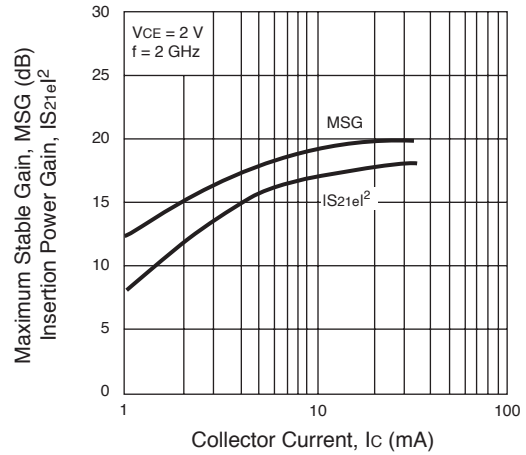

MAXIMUM AVAILABLE GAIN,
INSERTION POWER GAIN
vs. COLLECTOR CURRENT

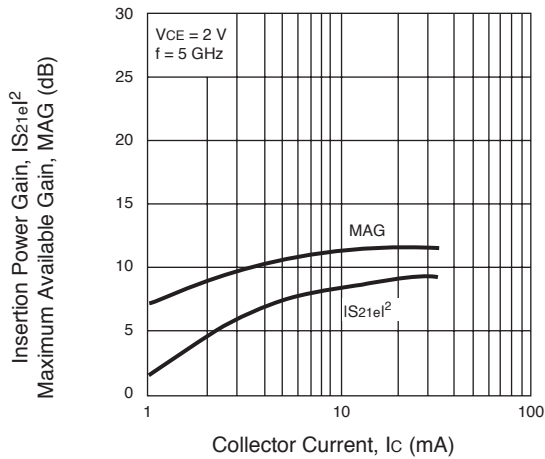

OUTPUT POWER, COLLECTOR
CURRENT vs. INPUT POWER

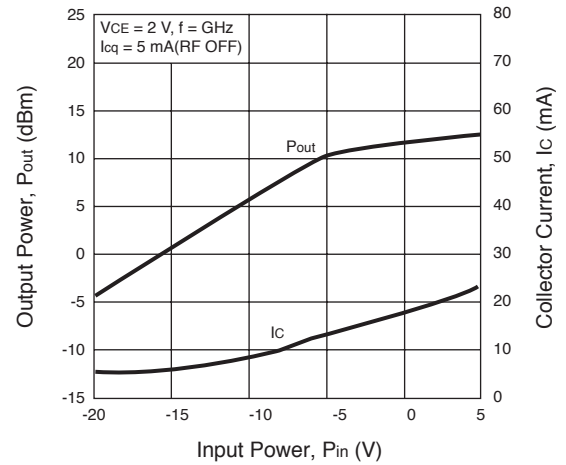

THIRD ORDER INTERMODULATION
DISTORTION
vs. OUTPUT POWER

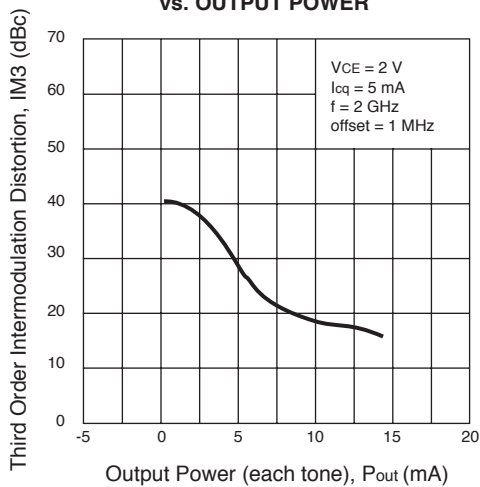

NOISE FIGURE AND ASSOCIATED
GAIN vs. COLLECTOR CURRENT

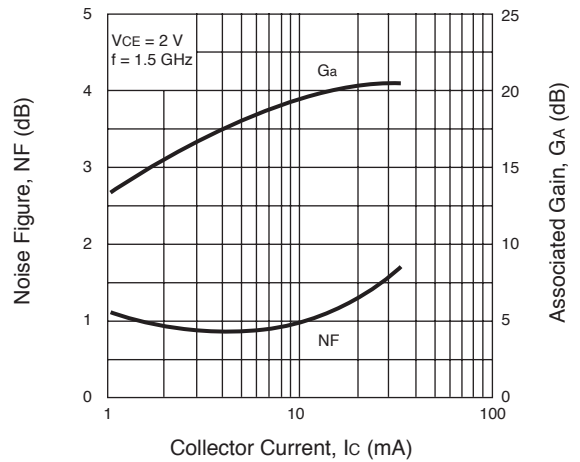

TYPICAL PERFORMANCE CURVES (T_A = 25°C)

NOISE FIGURE AND ASSOCIATED GAIN vs. COLLECTOR CURRENT

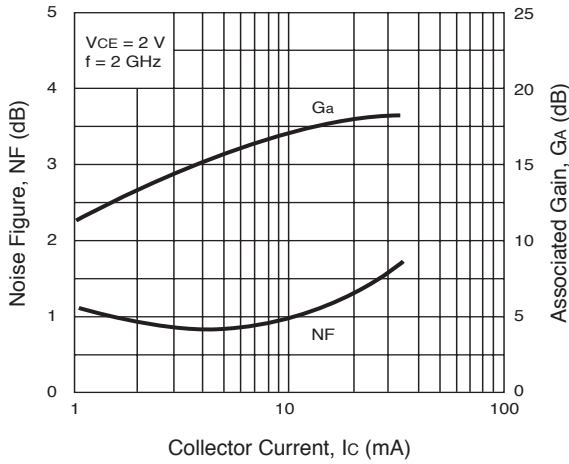

NOISE FIGURE AND ASSOCIATED GAIN vs. COLLECTOR CURRENT

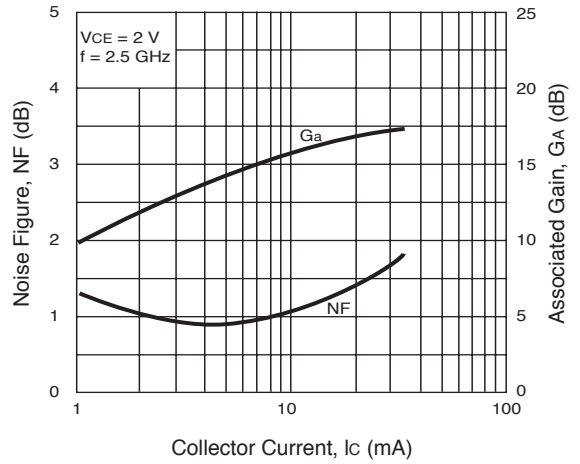

NOISE FIGURE AND ASSOCIATED GAIN vs. COLLECTOR CURRENT

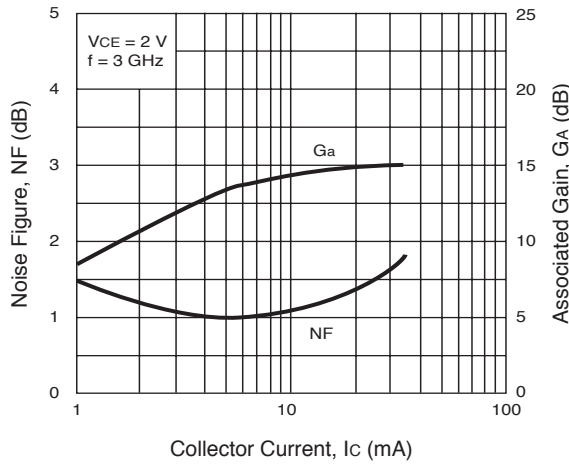

NOISE FIGURE AND ASSOCIATED GAIN vs. COLLECTOR CURRENT

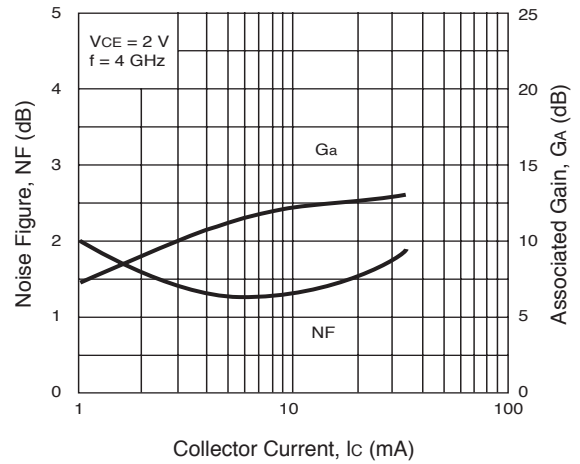

NOISE FIGURE AND ASSOCIATED GAIN vs. COLLECTOR CURRENT

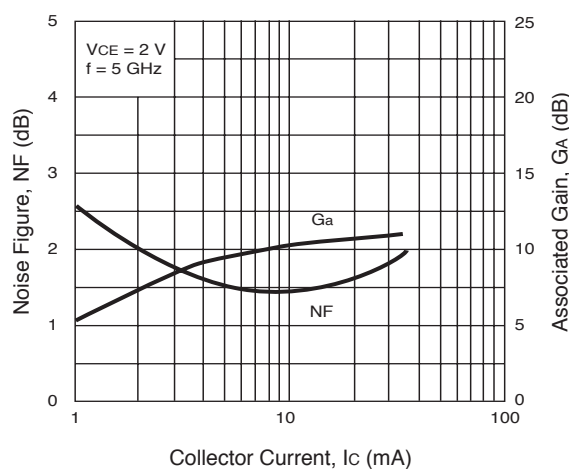

TYPICAL NOISE PARAMETERS (TA = 25°C)

FREQ. (GHz)	NFMIN (dB)	GA (dB)	ΓOPT		Rn/50
			MAG	ANG	
VCE = 2 V, IC = 5 mA					
0.8	0.77	22.62	0.440	22.0	0.21
0.9	0.77	21.79	0.433	25.3	0.21
1.0	0.78	21.03	0.426	28.6	0.20
1.1	0.78	20.33	0.418	32.0	0.20
1.2	0.79	19.69	0.410	35.5	0.19
1.3	0.79	19.10	0.402	39.0	0.19
1.4	0.80	18.56	0.394	42.6	0.18
1.5	0.81	18.05	0.386	46.3	0.18
1.7	0.82	17.13	0.372	54.0	0.17
1.9	0.84	16.31	0.359	62.1	0.16
2.0	0.85	15.94	0.354	66.3	0.16
2.2	0.87	15.26	0.345	74.9	0.15
2.4	0.89	14.64	0.340	83.6	0.14
2.5	0.91	14.36	0.338	87.9	0.14
2.7	0.93	13.83	0.338	96.4	0.13
3.0	0.98	13.12	0.342	108.6	0.12
3.5	1.06	12.12	0.354	126.4	0.11
4.0	1.15	11.31	0.354	141.4	0.09
4.5	1.26	10.63	0.325	155.7	0.08
VCE = 2 V, IC = 10 mA					
0.8	0.95	24.28	0.264	18.6	0.18
0.9	0.95	23.43	0.261	21.8	0.18
1.0	0.95	22.65	0.257	25.1	0.18
1.1	0.95	21.93	0.253	28.5	0.17
1.2	0.95	21.27	0.249	32.0	0.17
1.3	0.95	20.65	0.244	35.6	0.17
1.4	0.96	20.08	0.239	39.3	0.17
1.5	0.96	19.54	0.234	43.2	0.16
1.7	0.96	18.56	0.226	51.5	0.16
1.9	0.97	17.70	0.219	60.4	0.15
2.0	0.98	17.30	0.216	65.0	0.15
2.2	0.99	16.56	0.213	74.6	0.14
2.4	1.00	15.89	0.213	84.2	0.14
2.5	1.01	15.58	0.214	88.9	0.13
2.7	1.03	15.00	0.219	98.1	0.13
3.0	1.06	14.23	0.229	108.6	0.12
3.5	1.12	13.13	0.249	110.7	0.11
4.0	1.19	12.23	0.258	142.4	0.10
4.5	1.27	11.48	0.243	156.3	0.10
VCE = 2 V, IC = 20 mA					
0.8	1.26	25.33	0.082	14.2	0.17
0.9	1.25	24.45	0.081	17.4	0.17
1.0	1.25	23.65	0.079	20.9	0.17
1.1	1.25	22.91	0.076	24.9	0.17
1.2	1.25	22.23	0.074	29.4	0.17
1.3	1.25	21.60	0.071	34.5	0.16
1.4	1.25	21.01	0.068	40.4	0.16
1.5	1.25	20.46	0.065	47.1	0.16
1.7	1.25	19.46	0.061	63.0	0.15
1.9	1.26	18.57	0.062	81.1	0.15

TYPICAL NOISE PARAMETERS (CONT')

FREQ. (GHz)	NFMIN (dB)	GA (dB)	ΓOPT		Rn/50
			MAG	ANG	
VCE = 2 V, IC = 20 mA					
2.0	1.26	18.16	0.064	90.1	0.15
2.2	1.27	17.40	0.072	106.5	0.15
2.4	1.28	16.71	0.083	119.5	0.14
2.5	1.28	16.39	0.090	124.8	0.14
2.7	1.30	15.79	0.105	133.5	0.14
3.0	1.32	14.97	0.128	143.2	0.13
3.5	1.36	13.81	0.159	154.7	0.13
4.0	1.42	12.84	0.175	164.5	0.12
4.5	1.48	12.02	0.169	176.7	0.12

OUTLINE DIMENSIONS (Units in mm)

**PACKAGE OUTLINE M04
FLAT LEAD 4-PIN THIN TYPE SUPER MINIMOLD**

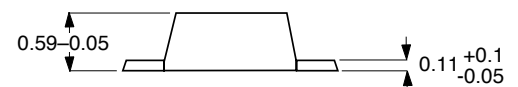
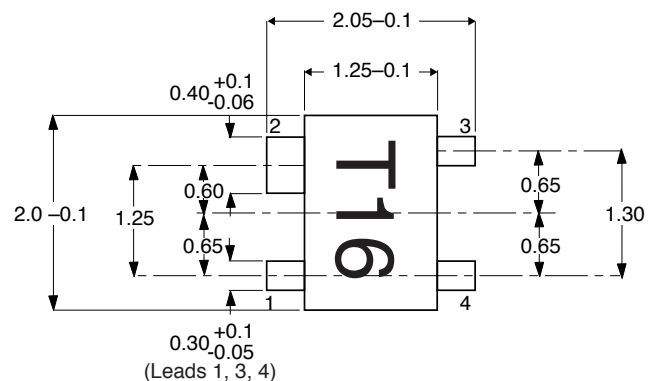
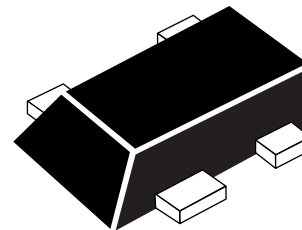

PIN CONNECTIONS

- 1. Emitter
- 2. Collector
- 3. Emitter
- 4. Base

TYPICAL SCATTERING PARAMETERS (TA = 25°C)

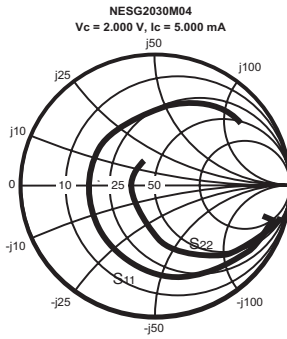

0.100 to 12.000GHz by 0.100

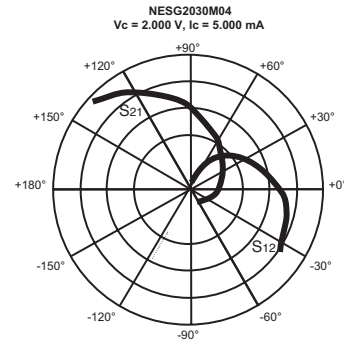

0.100 to 12.000GHz by 0.100

NESG2030M04
Vc = 2 V, Ic = 5 mA

FREQUENCY GHz	S11		S21		S12		S22		MAG ¹ (dB)	K
	MAG	ANG	MAG	ANG	MAG	ANG	MAG	ANG		
0.10	0.880	-15.9	11.079	176.4	0.010	81.3	1.072	1.2	30.33	-0.13
0.20	0.917	-16.4	11.423	166.9	0.020	76.8	0.972	-13.5	27.67	0.08
0.30	0.912	-22.9	10.960	160.1	0.028	71.1	0.917	-19.9	25.95	0.14
0.40	0.884	-31.7	10.799	153.7	0.036	66.4	0.884	-24.8	24.77	0.17
0.50	0.870	-37.6	10.505	148.6	0.043	62.5	0.848	-30.7	23.89	0.18
0.60	0.832	-45.4	10.169	143.2	0.049	58.6	0.820	-34.6	23.14	0.21
0.70	0.815	-52.2	9.830	138.3	0.055	55.2	0.784	-39.2	22.51	0.23
0.80	0.785	-59.0	9.524	133.2	0.060	51.6	0.742	-43.4	21.98	0.26
0.90	0.755	-65.4	9.156	128.9	0.065	48.9	0.721	-46.7	21.49	0.29
1.00	0.734	-71.6	8.829	124.6	0.069	46.2	0.686	-50.5	21.07	0.31
1.10	0.703	-77.9	8.446	120.6	0.073	43.6	0.663	-53.6	20.65	0.34
1.20	0.685	-83.7	8.165	116.5	0.076	41.2	0.631	-57.1	20.31	0.36
1.30	0.663	-89.9	7.848	112.8	0.079	38.9	0.606	-59.8	19.97	0.39
1.40	0.644	-95.4	7.554	109.3	0.082	36.9	0.582	-62.9	19.65	0.41
1.50	0.625	-100.9	7.255	105.9	0.084	35.0	0.560	-65.5	19.36	0.44
1.60	0.608	-106.1	6.959	102.6	0.086	33.2	0.538	-68.1	19.08	0.46
1.70	0.590	-111.5	6.714	99.5	0.088	31.6	0.521	-70.5	18.82	0.49
1.80	0.577	-116.7	6.482	96.5	0.090	30.1	0.502	-72.9	18.58	0.51
1.90	0.565	-121.4	6.206	93.7	0.091	28.7	0.486	-74.8	18.33	0.54
2.00	0.552	-126.2	5.992	90.9	0.092	27.4	0.470	-77.0	18.12	0.56
2.10	0.543	-131.2	5.811	88.1	0.094	26.0	0.454	-79.2	17.92	0.58
2.20	0.533	-135.6	5.598	85.6	0.095	25.0	0.442	-81.1	17.70	0.61
2.30	0.526	-140.1	5.404	83.2	0.096	23.9	0.429	-82.4	17.50	0.63
2.40	0.521	-144.3	5.214	80.8	0.097	22.9	0.418	-84.3	17.29	0.65
2.50	0.514	-148.5	5.052	78.4	0.098	22.0	0.407	-85.7	17.11	0.68
2.60	0.511	-152.6	4.901	76.1	0.099	21.1	0.398	-87.2	16.95	0.70
2.70	0.507	-156.5	4.748	73.8	0.100	20.3	0.386	-88.8	16.76	0.72
2.80	0.504	-160.3	4.607	71.8	0.101	19.4	0.378	-90.1	16.59	0.74
2.90	0.502	-163.7	4.463	69.6	0.102	18.7	0.369	-91.4	16.42	0.76
3.00	0.498	-167.6	4.358	67.5	0.103	18.0	0.361	-92.9	16.27	0.78
3.50	0.495	176.3	3.814	57.7	0.107	14.8	0.327	-98.3	15.52	0.87
4.00	0.496	161.7	3.399	48.6	0.111	12.0	0.298	-102.6	14.85	0.95
4.50	0.502	148.2	3.067	39.8	0.116	9.5	0.273	-107.0	13.45	1.02
5.00	0.512	135.5	2.802	31.3	0.121	7.1	0.249	-111.5	12.05	1.07
5.50	0.526	123.3	2.577	22.9	0.125	4.3	0.226	-117.7	11.07	1.11
6.00	0.544	112.1	2.380	14.8	0.130	1.7	0.206	-125.8	10.30	1.15
6.50	0.564	101.8	2.198	6.7	0.134	-1.4	0.192	-135.4	9.60	1.18
7.00	0.590	92.5	2.036	-1.1	0.139	-4.5	0.183	-147.1	9.05	1.19
8.00	0.645	76.9	1.746	-16.1	0.144	-10.7	0.179	-172.0	8.09	1.21
9.00	0.700	65.4	1.499	-30.0	0.149	-16.8	0.185	163.7	7.32	1.20
10.00	0.751	55.9	1.293	-43.0	0.151	-23.1	0.190	141.0	6.69	1.19
11.00	0.789	46.7	1.141	-55.2	0.155	-29.3	0.205	121.6	6.26	1.16
12.00	0.809	37.0	1.040	-66.6	0.163	-35.4	0.228	111.6	6.00	1.11

Note:

1. Gain Calculations:

$$MAG = \frac{|S_{21}|}{|S_{12}|} \left(K \pm \sqrt{K^2 - 1} \right). \text{ When } K \leq 1, \text{ MAG is undefined and MSG values are used. } MSG = \frac{|S_{21}|}{|S_{12}|}, K = \frac{1 + |\Delta|^2 - |S_{11}|^2 - |S_{22}|^2}{2 |S_{12}| S_{21}}, \Delta = S_{11} S_{22} - S_{21} S_{12}$$

MAG = Maximum Available Gain

MSG = Maximum Stable Gain

TYPICAL SCATTERING PARAMETERS (TA = 25°C)

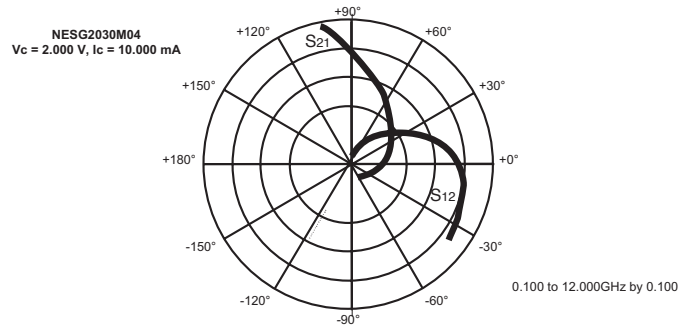
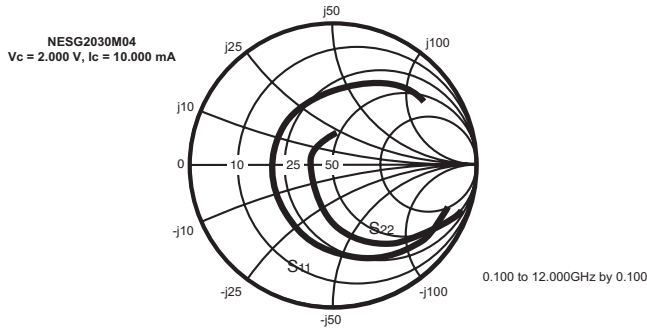

NESG2030M04

Vds = 2 V, Ids = 10 mA

FREQUENCY	S11		S21		S12		S22		MAG ¹	K
GHz	MAG	ANG	MAG	ANG	MAG	ANG	MAG	ANG	(dB)	
0.10	0.843	-18.3	17.945	175.1	0.010	82.5	1.060	-0.7	32.56	-0.11
0.20	0.861	-21.3	18.266	163.8	0.019	73.7	0.951	-17.8	29.85	0.12
0.30	0.842	-29.5	17.254	155.5	0.026	67.8	0.882	-25.7	28.15	0.19
0.40	0.802	-40.1	16.649	148.2	0.034	63.3	0.835	-32.1	26.93	0.22
0.50	0.776	-47.3	15.854	142.3	0.040	58.8	0.790	-39.3	26.01	0.25
0.60	0.730	-56.4	15.040	136.3	0.045	55.3	0.749	-44.1	25.26	0.28
0.70	0.704	-64.0	14.268	131.0	0.050	52.3	0.706	-49.5	24.57	0.31
0.80	0.667	-71.6	13.490	125.7	0.054	49.3	0.656	-54.5	24.01	0.35
0.90	0.635	-78.8	12.769	121.3	0.057	46.6	0.629	-58.3	23.51	0.38
1.00	0.610	-85.4	12.100	117.0	0.060	44.6	0.591	-62.6	23.03	0.41
1.10	0.581	-92.3	11.435	113.0	0.063	42.6	0.563	-66.1	22.59	0.45
1.20	0.561	-98.2	10.861	109.2	0.065	41.0	0.532	-70.0	22.20	0.48
1.30	0.541	-104.7	10.311	105.7	0.068	39.4	0.506	-73.1	21.83	0.51
1.40	0.524	-110.4	9.810	102.4	0.070	38.0	0.482	-76.5	21.47	0.54
1.50	0.508	-116.0	9.335	99.3	0.072	36.7	0.461	-79.3	21.14	0.57
1.60	0.494	-121.3	8.887	96.3	0.074	35.5	0.440	-82.3	20.82	0.60
1.70	0.481	-126.8	8.494	93.4	0.075	34.6	0.424	-84.8	20.52	0.62
1.80	0.471	-132.0	8.130	90.7	0.077	33.7	0.407	-87.6	20.25	0.65
1.90	0.462	-136.7	7.765	88.2	0.079	32.7	0.392	-89.7	19.95	0.67
2.00	0.453	-141.5	7.450	85.7	0.080	32.0	0.378	-92.2	19.68	0.70
2.10	0.448	-146.3	7.166	83.2	0.081	31.3	0.365	-94.6	19.45	0.72
2.20	0.442	-150.6	6.881	80.9	0.083	30.6	0.354	-96.8	19.19	0.75
2.30	0.439	-154.8	6.624	78.7	0.084	29.9	0.343	-98.4	18.95	0.77
2.40	0.437	-158.9	6.378	76.5	0.086	29.2	0.333	-100.6	18.71	0.79
2.50	0.433	-162.8	6.156	74.4	0.087	28.8	0.323	-102.1	18.48	0.81
2.60	0.434	-166.7	5.954	72.4	0.089	28.1	0.316	-103.9	18.26	0.82
2.70	0.431	-170.3	5.751	70.3	0.090	27.6	0.306	-105.9	18.06	0.84
2.80	0.431	-173.8	5.571	68.4	0.091	27.2	0.300	-107.3	17.85	0.86
2.90	0.430	-177.0	5.391	66.5	0.093	26.6	0.291	-109.1	17.64	0.88
3.00	0.430	179.5	5.238	64.6	0.095	26.2	0.285	-110.5	17.43	0.89
3.50	0.434	164.9	4.558	55.6	0.102	23.4	0.255	-117.4	16.51	0.96
4.00	0.439	151.7	4.043	47.1	0.110	21.0	0.229	-123.2	15.19	1.01
4.50	0.448	139.5	3.636	38.9	0.117	18.0	0.206	-129.4	13.59	1.05
5.00	0.462	128.0	3.310	30.9	0.125	14.7	0.184	-136.6	12.56	1.07
5.50	0.478	117.0	3.034	23.0	0.133	11.1	0.167	-146.4	11.69	1.10
6.00	0.498	106.8	2.795	15.3	0.140	7.4	0.155	-158.5	10.97	1.11
6.50	0.521	97.3	2.582	7.7	0.147	3.5	0.152	-172.3	10.32	1.12
7.00	0.549	88.8	2.391	0.2	0.152	-0.5	0.155	173.5	9.78	1.13
8.00	0.609	74.5	2.052	-14.1	0.160	-8.7	0.175	147.8	8.83	1.14
9.00	0.670	63.9	1.767	-27.6	0.164	-16.5	0.199	125.4	8.07	1.14
10.00	0.724	55.1	1.530	-40.3	0.167	-24.1	0.218	104.0	7.43	1.13
11.00	0.765	46.3	1.352	-52.4	0.169	-31.6	0.240	87.7	6.97	1.12
12.00	0.786	36.9	1.238	-63.6	0.174	-38.7	0.253	79.4	6.66	1.09

Note:

1. Gain Calculations:

$$MAG = \frac{|S_{21}|}{|S_{12}|} (K \pm \sqrt{K^2 - 1}). \text{ When } K \leq 1, \text{ MAG is undefined and MSG values are used. } MSG = \frac{|S_{21}|}{|S_{12}|}, K = \frac{1 + |\Delta|^2 - |S_{11}|^2 - |S_{22}|^2}{2 |S_{12}| |S_{21}|}, \Delta = S_{11} S_{22} - S_{21} S_{12}$$

MAG = Maximum Available Gain

MSG = Maximum Stable Gain

TYPICAL SCATTERING PARAMETERS (TA = 25°C)

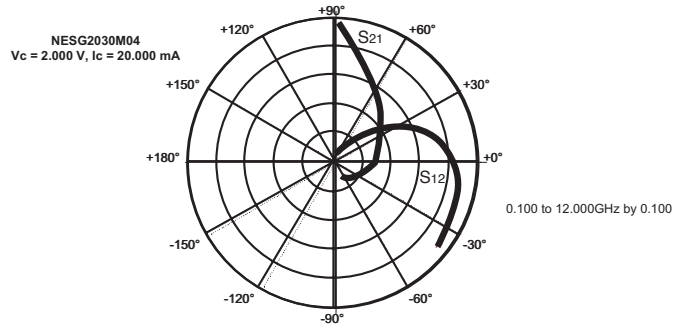
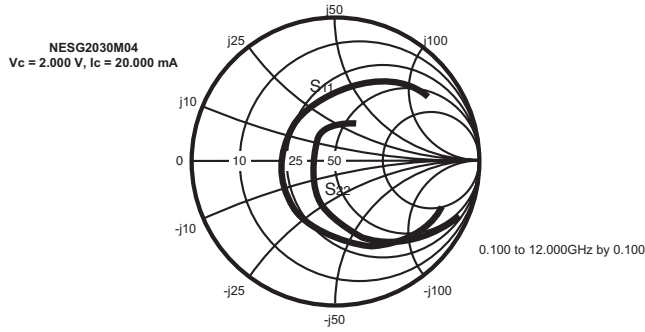

NESG2030M04

VDS = 2 V, IDS = 20 mA

FREQUENCY GHz	S11		S21		S12		S22		MAG ¹ (dB)	K
	MAG	ANG	MAG	ANG	MAG	ANG	MAG	ANG		
0.10	0.786	- 21.3	25.785	173.5	0.009	84.5	1.044	- 2.9	34.58	- 0.13
0.20	0.783	- 27.1	25.691	160.2	0.018	70.6	0.924	- 22.3	31.53	0.16
0.30	0.750	- 36.9	23.773	150.7	0.025	64.7	0.840	- 31.8	29.79	0.25
0.40	0.700	- 49.4	22.359	142.5	0.031	60.2	0.778	- 39.8	28.59	0.29
0.50	0.667	- 57.6	20.800	136.0	0.036	56.6	0.725	- 47.9	27.61	0.32
0.60	0.619	- 67.9	19.318	129.8	0.040	53.2	0.675	- 53.5	26.80	0.37
0.70	0.590	- 76.2	17.984	124.4	0.044	50.7	0.628	- 59.6	26.10	0.40
0.80	0.554	- 84.4	16.687	119.2	0.047	48.2	0.575	- 65.2	25.48	0.45
0.90	0.525	- 92.1	15.577	114.9	0.050	46.7	0.546	- 69.2	24.94	0.49
1.00	0.502	- 99.0	14.563	110.8	0.053	45.2	0.510	- 74.0	24.41	0.52
1.10	0.479	-106.4	13.636	107.0	0.055	43.8	0.482	- 77.8	23.95	0.56
1.20	0.462	-112.4	12.805	103.5	0.057	42.7	0.453	- 82.1	23.50	0.60
1.30	0.447	-119.0	12.055	100.2	0.059	41.8	0.429	- 85.5	23.08	0.63
1.40	0.435	-124.8	11.384	97.2	0.061	41.1	0.408	- 89.2	22.69	0.66
1.50	0.423	-130.5	10.772	94.3	0.063	40.2	0.390	- 92.3	22.32	0.69
1.60	0.414	-135.7	10.209	91.6	0.065	39.5	0.372	- 95.7	21.96	0.72
1.70	0.406	-141.2	9.703	89.0	0.067	38.9	0.358	- 98.3	21.61	0.74
1.80	0.401	-146.1	9.243	86.5	0.069	38.4	0.345	-101.5	21.27	0.76
1.90	0.395	-150.8	8.810	84.2	0.071	38.0	0.332	-103.9	20.95	0.79
2.00	0.391	-155.4	8.424	82.0	0.072	37.4	0.321	-106.7	20.65	0.81
2.10	0.389	-160.0	8.071	79.7	0.074	36.9	0.311	-109.3	20.37	0.83
2.20	0.387	-164.0	7.735	77.6	0.076	36.5	0.303	-111.8	20.05	0.85
2.30	0.386	-168.0	7.433	75.6	0.078	36.2	0.293	-113.8	19.79	0.87
2.40	0.387	-171.7	7.147	73.6	0.080	35.5	0.286	-116.1	19.53	0.88
2.50	0.386	-175.4	6.886	71.7	0.082	35.2	0.279	-118.1	19.25	0.90
2.60	0.389	-178.9	6.649	69.8	0.083	34.6	0.272	-120.2	19.02	0.91
2.70	0.388	177.9	6.413	67.9	0.085	34.1	0.265	-122.3	18.76	0.92
2.80	0.389	174.7	6.207	66.1	0.088	33.5	0.260	-124.1	18.51	0.93
2.90	0.390	171.7	6.003	64.3	0.089	33.3	0.254	-126.1	18.27	0.95
3.00	0.391	168.5	5.819	62.6	0.091	32.7	0.249	-127.7	18.05	0.96
3.50	0.399	155.4	5.046	54.1	0.101	30.0	0.226	-136.1	16.90	1.00
4.00	0.407	143.5	4.465	46.1	0.111	27.0	0.205	-143.5	14.98	1.03
4.50	0.418	132.5	4.009	38.3	0.121	23.4	0.187	-152.0	13.81	1.05
5.00	0.432	122.0	3.642	30.7	0.131	19.4	0.171	-161.7	12.87	1.07
5.50	0.450	112.0	3.333	23.1	0.139	15.1	0.163	-173.7	12.05	1.08
6.00	0.472	102.6	3.066	15.6	0.148	10.9	0.164	173.3	11.36	1.09
6.50	0.496	93.8	2.832	8.3	0.155	6.2	0.172	160.4	10.73	1.09
7.00	0.525	85.9	2.621	1.1	0.162	1.6	0.186	148.1	10.20	1.10
8.00	0.588	72.5	2.251	- 12.7	0.170	- 7.4	0.221	127.1	9.26	1.10
9.00	0.651	62.5	1.940	- 25.9	0.175	- 16.1	0.254	107.8	8.49	1.10
10.00	0.707	54.3	1.682	- 38.3	0.177	- 24.6	0.282	88.7	7.85	1.10
11.00	0.750	45.8	1.488	- 50.2	0.178	- 32.8	0.306	73.7	7.36	1.09
12.00	0.771	36.6	1.367	- 61.2	0.182	- 40.3	0.316	64.9	7.01	1.08

Note:

1. Gain Calculations:

$$MAG = \frac{|S_{21}|}{|S_{12}|} (K \pm \sqrt{K^2 - 1})$$

When K ≤ 1, MAG is undefined and MSG values are used. $MSG = \frac{|S_{21}|}{|S_{12}|}$, $K = \frac{1 + |\Delta|^2 - |S_{11}|^2 - |S_{22}|^2}{2 |S_{12}| |S_{21}|}$, $\Delta = S_{11} S_{22} - S_{21} S_{12}$

MAG = Maximum Available Gain

MSG = Maximum Stable Gain

NESG2030M04 NONLINEAR MODEL

SCHEMATIC

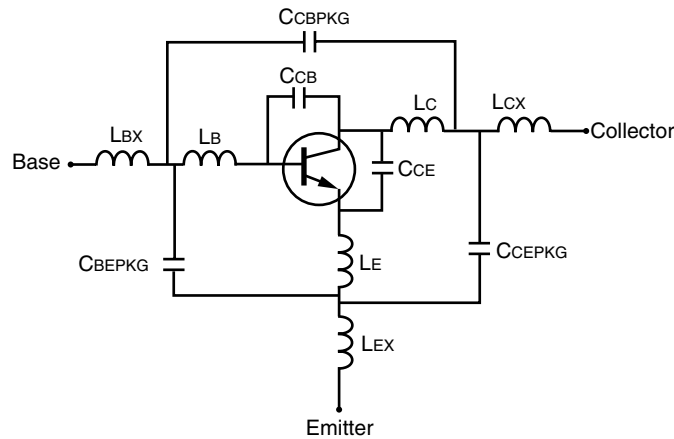

BJT NONLINEAR MODEL PARAMETERS (1)

Parameters	Q1	Parameters	Q1
IS	2.42e-13	MJC	0.16
BF	382	XCJC	1
NF	1.025	CJS	0
VAF	87	VJS	0.75
IKF	100	MJS	0
ISE	5.2e-13	FC	0.5
NE	2.806	TF	3e-12
BR	15.7	XTF	2
NR	1.02	VTF	0.1
VAR	1.307	ITF	0.001
IKR	0.037	PTF	0
ISC	9e-14	TR	50e-12
NC	2.194	EG	1.11
RE	2.2	XTB	0
RB	4	XTI	3
RBM	1	KF	120e-15
IRB	0.007	AF	1.37
RC	4.2		
CJE	0.4e-12		
VJE	0.98		
MJE	0.25		
CJC	0.12e-12		
VJC	0.63		

ADDITIONAL PARAMETERS

Parameters	NESG2030M04
CCB	0.07e-12
CCE	0.05e-12
LB	0.9e-9
LC	0.5e-9
LE	0.14e-9
CCEPKG	0.001e-12
CCEPKG	0.2e-12
CBEPK	0.1e-12
LBX	0.2e-9
LCX	0.2e-9
LEX	0.1e-9

MODEL RANGE

Frequency: 0.1 to 12 GHz
 Bias: $V_{CE} = 0.5 \text{ V to } 3 \text{ V}$, $I_C = 1 \text{ mA to } 30 \text{ mA}$
 Date: 12/2001

(1) Gummel-Poon Model

Life Support Applications

These NEC products are not intended for use in life support devices, appliances, or systems where the malfunction of these products can reasonably be expected to result in personal injury. The customers of CEL using or selling these products for use in such applications do so at their own risk and agree to fully indemnify CEL for all damages resulting from such improper use or sale.

CEL California Eastern Laboratories, Your source for NEC RF, Microwave, Optoelectronic, and Fiber Optic Semiconductor Devices.

4590 Patrick Henry Drive • Santa Clara, CA 95054-1817 • (408) 919-2500 • FAX (408) 988-0279 • www.cel.com

DATA SUBJECT TO CHANGE WITHOUT NOTICE

Subject: Compliance with EU Directives

CEL certifies, to its knowledge, that semiconductor and laser products detailed below are compliant with the requirements of European Union (EU) Directive 2002/95/EC Restriction on Use of Hazardous Substances in electrical and electronic equipment (RoHS) and the requirements of EU Directive 2003/11/EC Restriction on Penta and Octa BDE.

CEL Pb-free products have the same base part number with a suffix added. The suffix –A indicates that the device is Pb-free. The –AZ suffix is used to designate devices containing Pb which are exempted from the requirement of RoHS directive (*). In all cases the devices have Pb-free terminals. All devices with these suffixes meet the requirements of the RoHS directive.

This status is based on CEL’s understanding of the EU Directives and knowledge of the materials that go into its products as of the date of disclosure of this information.

Restricted Substance per RoHS	Concentration Limit per RoHS (values are not yet fixed)	Concentration contained in CEL devices	
		-A	-AZ
Lead (Pb)	< 1000 PPM	Not Detected	(*)
Mercury	< 1000 PPM	Not Detected	
Cadmium	< 100 PPM	Not Detected	
Hexavalent Chromium	< 1000 PPM	Not Detected	
PBB	< 1000 PPM	Not Detected	
PBDE	< 1000 PPM	Not Detected	

If you should have any additional questions regarding our devices and compliance to environmental standards, please do not hesitate to contact your local representative.

Important Information and Disclaimer: Information provided by CEL on its website or in other communications concerning the substance content of its products represents knowledge and belief as of the date that it is provided. CEL bases its knowledge and belief on information provided by third parties and makes no representation or warranty as to the accuracy of such information. Efforts are underway to better integrate information from third parties. CEL has taken and continues to take reasonable steps to provide representative and accurate information but may not have conducted destructive testing or chemical analysis on incoming materials and chemicals. CEL and CEL suppliers consider certain information to be proprietary, and thus CAS numbers and other limited information may not be available for release.

In no event shall CEL’s liability arising out of such information exceed the total purchase price of the CEL part(s) at issue sold by CEL to customer on an annual basis.

See CEL Terms and Conditions for additional clarification of warranties and liability.

Looking for pricing, stock, or lifecycle information?

Click below to explore more details on WIN SOURCE:

 [View NESG2030M04-A on WIN SOURCE](#)

 [CEL Information](#)

Optimize Your Supply Chain with WIN SOURCE Solutions

-  Global Sourcing Solution
-  Obsolete Management
-  Cost Control Management
-  Shortage Management
-  Alternative Solution
-  Excess Inventory Management