



THE DATASHEET OF STF11N50M2



N-channel 500 V, 0.45 Ω typ., 8 A MDmesh™ M2 Power MOSFETs in DPAK and TO-220FP packages



DPAK

TO-220FP

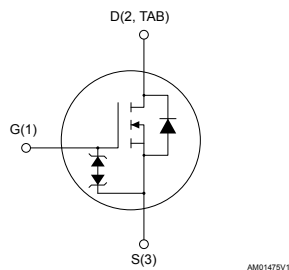

AM01479V1

Features

Order code	$V_{DS} @ T_{Jmax}$	$R_{DS(on)max.}$	I_D	Package
STD11N50M2	550 V	0.53 Ω	8 A	DPAK
STF11N50M2				TO-220FP

- Extremely low gate charge
- Excellent output capacitance (C_{OSS}) profile
- 100% avalanche tested
- Zener-protected

Applications

- Switching applications

Description

These devices are N-channel Power MOSFETs developed using the MDmesh™ M2 technology. Thanks to their strip layout and improved vertical structure, these devices exhibit low on-resistance and optimized switching characteristics, rendering them suitable for the most demanding high-efficiency converters.



Product status

STD11N50M2

STF11N50M2

Product summary

Order code	STD11N50M2
Marking	11N50M2
Package	DPAK
Packing	Tape and reel
Order code	STF11N50M2
Marking	11N50M2
Package	TO-220FP
Packing	Tube

1 Electrical ratings

Table 1. Absolute maximum ratings

Symbol	Parameter	Value		Unit
		DPAK	TO-220FP	
V_{GS}	Gate-source voltage	±25		V
I_D	Drain current (continuous) at $T_C = 25\text{ °C}$	8		A
I_D	Drain current (continuous) at $T_C = 100\text{ °C}$	5		A
$I_{DM}^{(1)}$	Drain current (pulsed)	32		A
P_{TOT}	Total power dissipation at $T_C = 25\text{ °C}$	85	25	W
$dv/dt^{(2)}$	Peak diode recovery voltage slope	15		V/ns
$dv/dt^{(3)}$	MOSFET dv/dt ruggedness	50		V/ns
V_{ISO}	Insulation withstand voltage (RMS) from all three leads to external heat sink ($t=1\text{ s}$; $T_C = 25\text{ °C}$)	2.5		kV
T_j	Operating junction temperature range	-55 to 150		°C
T_{stg}	Storage temperature range			

1. Pulse width limited by safe operating area.
2. $I_{SD} \leq 8\text{ A}$, $di/dt \leq 400\text{ A}/\mu\text{s}$, $V_{DS(peak)} < V_{(BR)DSS}$, $V_{DD} = 400\text{ V}$.
3. $V_{DS} \leq 400\text{ V}$.

Table 2. Thermal data

Symbol	Parameter	Value		Unit
		DPAK	TO-220FP	
$R_{thj-case}$	Thermal resistance junction-case	1.47	5	°C/W
$R_{thj-pcb}^{(1)}$	Thermal resistance junction-pcb	50		°C/W
$R_{thj-amb}$	Thermal resistance junction-ambient		62.5	°C/W

1. When mounted on 1 inch² FR-4, 2 Oz copper board.

Table 3. Avalanche characteristics

Symbol	Parameter	Value	Unit
I_{AR}	Avalanche current, repetitive or not-repetitive (pulse width limited by T_j Max)	2	A
E_{AS}	Single pulse avalanche energy (starting $T_j = 25\text{ °C}$, $I_D = I_{AR}$, $V_{DD} = 50\text{ V}$)	190	mJ

2 Electrical characteristics

($T_{CASE} = 25\text{ }^{\circ}\text{C}$ unless otherwise specified)

Table 4. On/off states

Symbol	Parameter	Test conditions	Min.	Typ.	Max.	Unit
$V_{(BR)DSS}$	Drain-source breakdown voltage	$I_D = 1\text{ mA}$, $V_{GS} = 0\text{ V}$	500			V
I_{DSS}	Zero gate voltage drain current	$V_{DS} = 500\text{ V}$, $V_{GS} = 0\text{ V}$			1	μA
		$V_{DS} = 500\text{ V}$, $V_{GS} = 0\text{ V}$, $T_C = 125\text{ }^{\circ}\text{C}$ ⁽¹⁾			100	μA
I_{GSS}	Gate body leakage current	$V_{DS} = 0\text{ V}$, $V_{GS} = \pm 25\text{ V}$			± 10	μA
$V_{GS(th)}$	Gate threshold voltage	$V_{DS} = V_{GS}$, $I_D = 250\text{ }\mu\text{A}$	2	3	4	V
$R_{DS(on)}$	Static drain-source on resistance	$V_{GS} = 10\text{ V}$, $I_D = 4\text{ A}$		0.45	0.53	Ω

1. Defined by design, not subject to production test.

Table 5. Dynamic

Symbol	Parameter	Test conditions	Min.	Typ.	Max.	Unit
C_{ISS}	Input capacitance	$V_{DS} = 100\text{ V}$, $f = 1\text{ MHz}$, $V_{GS} = 0\text{ V}$	-	395	-	μF
C_{OSS}	Output capacitance			26		
C_{RSS}	Reverse transfer capacitance			1		
$C_{OSS\text{ eq.}}^{(1)}$	Equivalent output capacitance	$V_{GS} = 0\text{ V}$, $V_{DS} = 0\text{ to }400\text{ V}$	-	108	-	μF
R_g	Gate input resistance	$f = 1\text{ MHz}$ open drain	-	6.3	-	Ω
Q_g	Total gate charge	$V_{DD} = 400\text{ V}$, $I_D = 8\text{ A}$, $V_{GS} = 0\text{ to }10\text{ V}$ (see Figure 16. Test circuit for gate charge behavior)	-	12	-	nC
Q_{gs}	Gate-source charge			2		
Q_{gd}	Gate-drain charge			6.4		

1. $C_{OSS\text{ eq.}}$ is defined as a constant equivalent capacitance giving the same charging time as C_{OSS} when V_{DS} increases from 0 to 80% V_{DSS} .

Table 6. Switching times

Symbol	Parameter	Test conditions	Min.	Typ.	Max.	Unit
$t_{d(on)}$	Turn-on delay time	$V_{DD} = 250\text{ V}$, $I_D = 4\text{ A}$, $R_G = 4.7\text{ }\Omega$, $V_{GS} = 10\text{ V}$ (see Figure 15. Test circuit for resistive load switching times and Figure 20. Switching time waveform)	-	11	-	ns
t_r	Rise time			9		
$t_{d(off)}$	Turn-off delay time			8		
t_f	Fall time			28.5		

Table 7. Source-drain diode

Symbol	Parameter	Test conditions	Min.	Typ.	Max.	Unit	
I_{SD}	Source-drain current		-		8	A	
$I_{SDM}^{(1)}$	Source-drain current (pulsed)				32		
$V_{SD}^{(2)}$	Forward on voltage	$I_{SD} = 8\text{ A}$, $V_{GS} = 0\text{ V}$	-		1.6	V	
t_{rr}	Reverse recovery time	$I_{SD} = 8\text{ A}$, $di/dt = 100\text{ A}/\mu\text{s}$ $V_{DD} = 60\text{ V}$ (see Figure 17. Test circuit for inductive load switching and diode recovery times)	-	258		ns	
Q_{rr}	Reverse recovery charge			1.84			μC
I_{RRM}	Reverse recovery current			14.3			
t_{rr}	Reverse recovery time	$I_{SD} = 8\text{ A}$, $di/dt = 100\text{ A}/\mu\text{s}$ $V_{DD} = 60\text{ V}$, $T_j = 150\text{ °C}$ (see Figure 17. Test circuit for inductive load switching and diode recovery times)	-	370		ns	
Q_{rr}	Reverse recovery charge			2.87			μC
I_{RRM}	Reverse recovery current			15.5			

1. Pulse width limited by safe operating area.

2. Pulsed: pulse duration = 300 μs, duty cycle 1.5%.

2.1 Electrical characteristics (curves)

Figure 1. Safe operating area for DPAK

Figure 2. Thermal impedance for DPAK

Figure 3. Safe operating area for TO-220FP

Figure 4. Thermal impedance for TO-220FP

Figure 5. Output characteristics

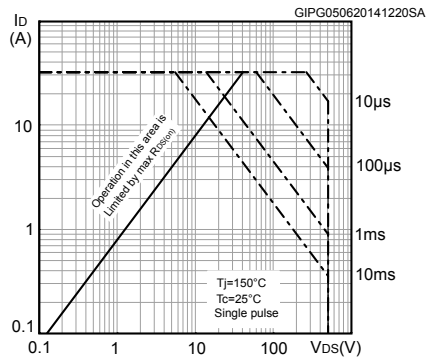
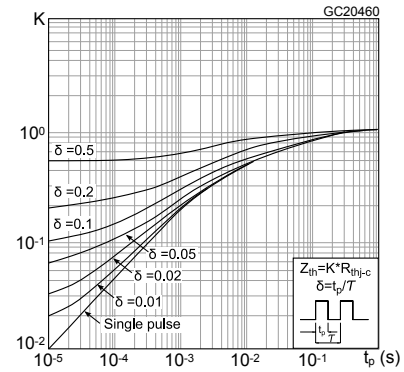
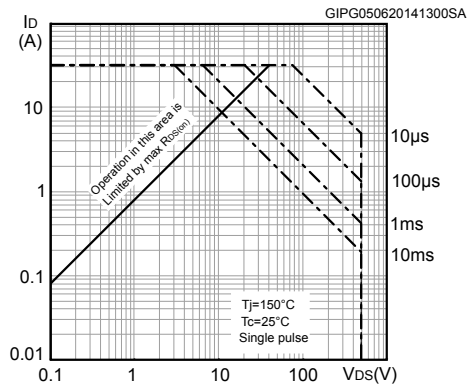
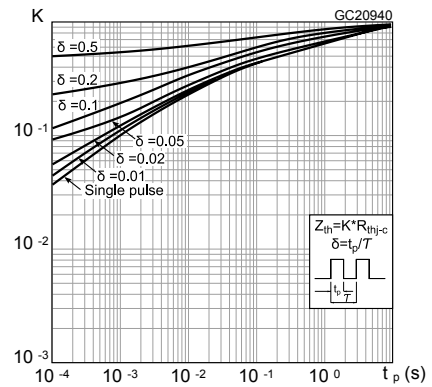
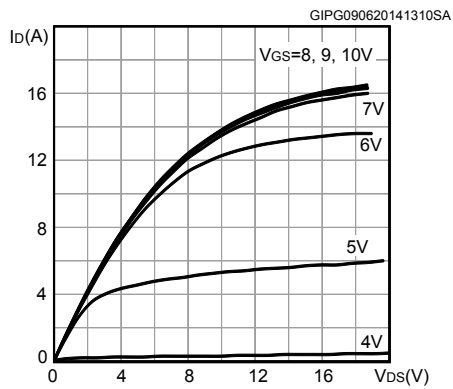
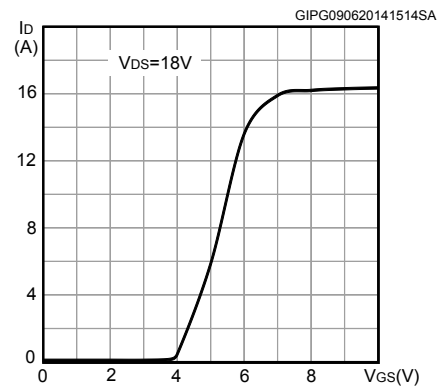
Figure 6. Transfer characteristics

Figure 7. Gate charge vs gate-source voltage

Figure 8. Static drain-source on-resistance

Figure 9. Capacitance variations

Figure 10. Output capacitance stored energy

Figure 11. Normalized gate threshold voltage vs temperature

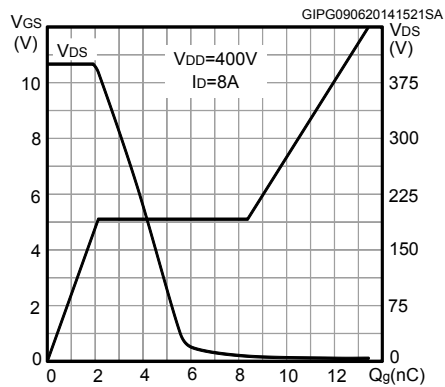
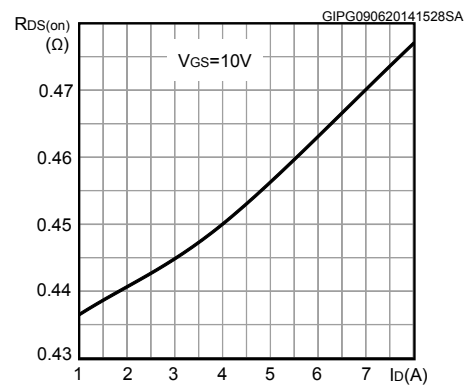
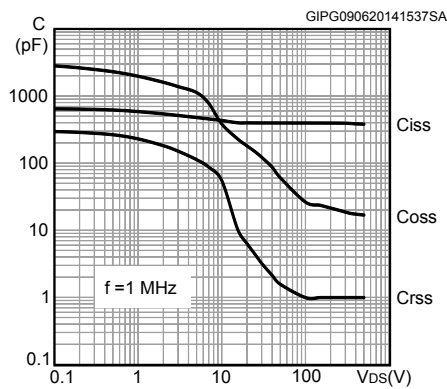
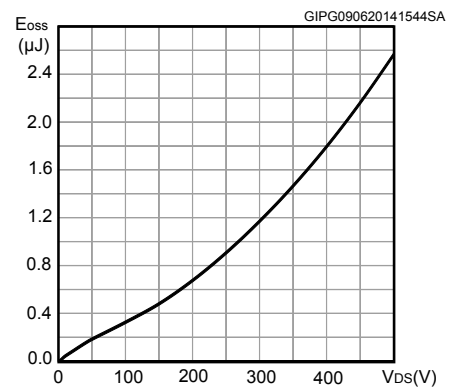
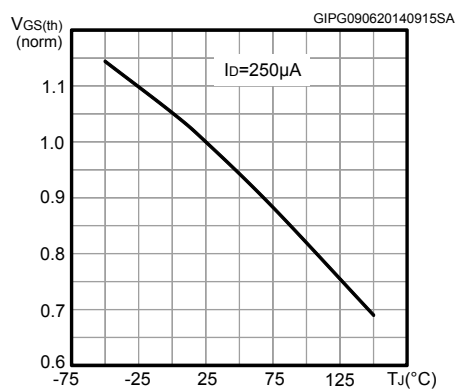
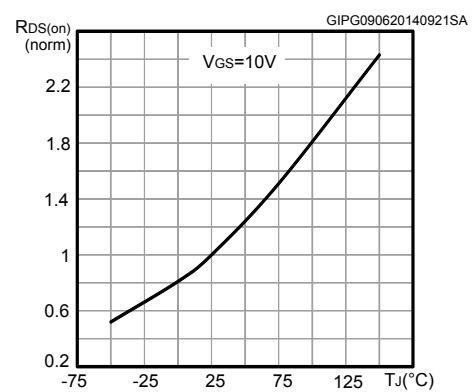
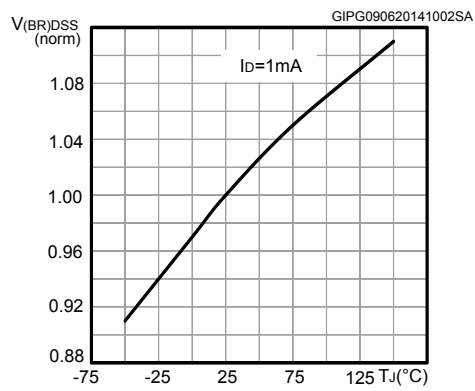
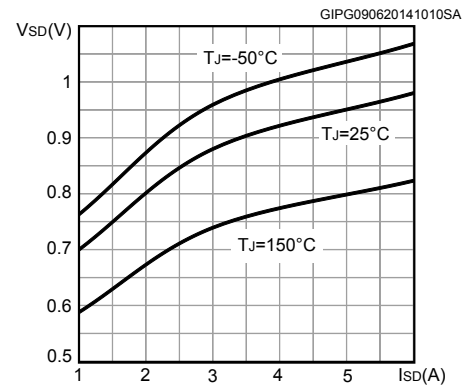
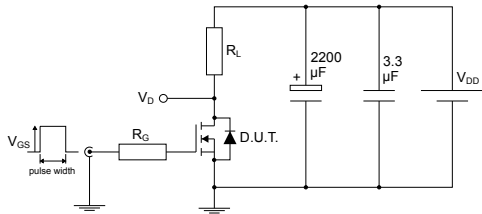
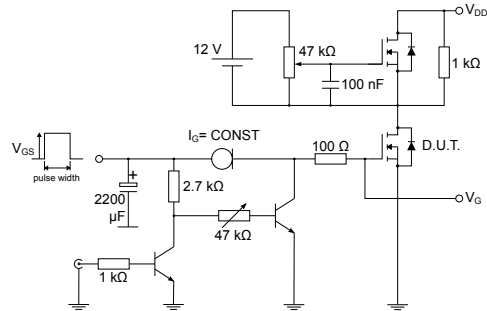
Figure 12. Normalized on-resistance vs temperature

Figure 13. Normalized $V_{(BR)DSS}$ vs temperature

Figure 14. Source-drain diode forward characteristics

3 Test circuits

Figure 15. Test circuit for resistive load switching times

AM01468v1

Figure 16. Test circuit for gate charge behavior

AM01469v1

Figure 17. Test circuit for inductive load switching and diode recovery times



AM01470v1

Figure 18. Unclamped inductive load test circuit

AM01471v1

Figure 19. Unclamped inductive waveform

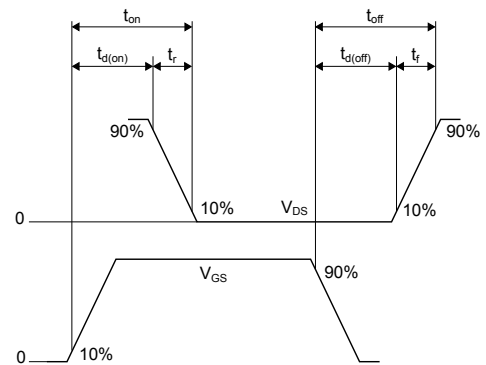
AM01472v1

Figure 20. Switching time waveform

AM01473v1

4 Package information

In order to meet environmental requirements, ST offers these devices in different grades of **ECOPACK[®]** packages, depending on their level of environmental compliance. ECOPACK[®] specifications, grade definitions and product status are available at: www.st.com. ECOPACK[®] is an ST trademark.

4.1 DPAK (TO-252) type A package information

Figure 21. DPAK (TO-252) type A package outline

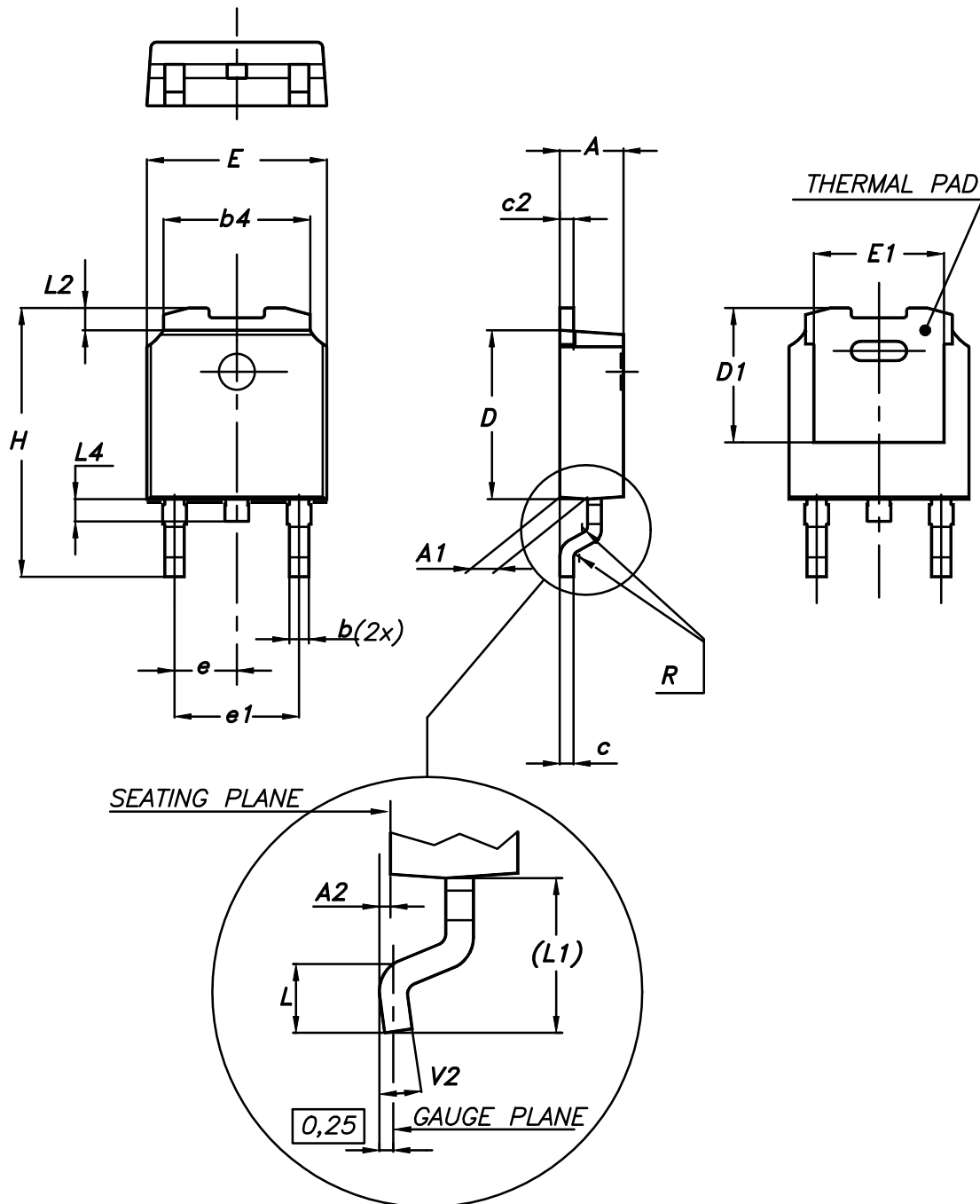

0068772_A_25

Table 8. DPAK (TO-252) type A mechanical data

Dim.	mm		
	Min.	Typ.	Max.
A	2.20		2.40
A1	0.90		1.10
A2	0.03		0.23
b	0.64		0.90
b4	5.20		5.40
c	0.45		0.60
c2	0.48		0.60
D	6.00		6.20
D1	4.95	5.10	5.25
E	6.40		6.60
E1	4.60	4.70	4.80
e	2.159	2.286	2.413
e1	4.445	4.572	4.699
H	9.35		10.10
L	1.00		1.50
(L1)	2.60	2.80	3.00
L2	0.65	0.80	0.95
L4	0.60		1.00
R		0.20	
V2	0°		8°

4.2 DPAK (TO-252) type C package information

Figure 22. DPAK (TO-252) type C package outline

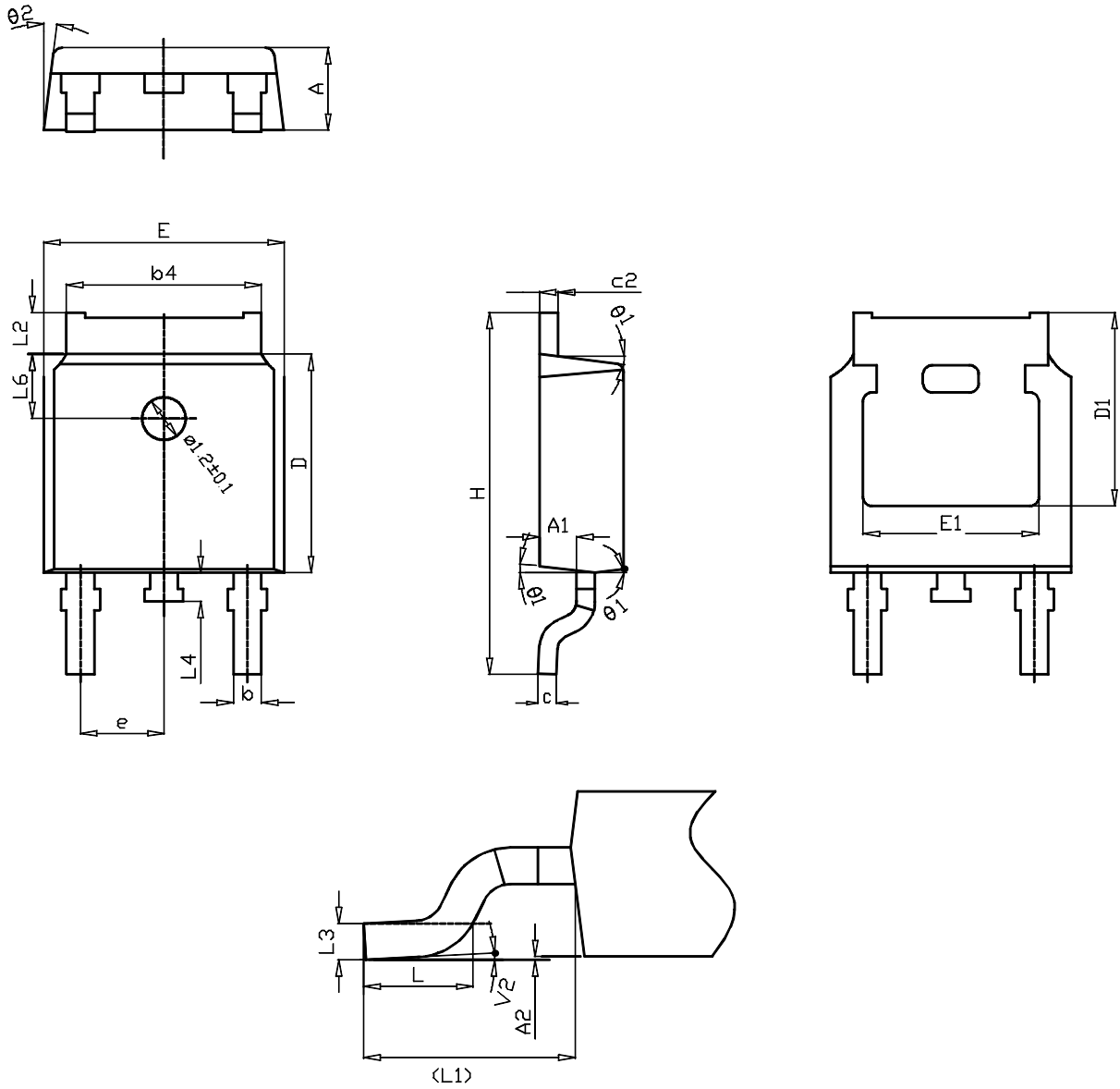

0068772_C_25

Table 9. DPAK (TO-252) type C mechanical data

Dim.	mm		
	Min.	Typ.	Max.
A	2.20	2.30	2.38
A1	0.90	1.01	1.10
A2	0.00		0.10
b	0.72		0.85
b4	5.13	5.33	5.46
c	0.47		0.60
c2	0.47		0.60
D	6.00	6.10	6.20
D1	5.25		
E	6.50	6.60	6.70
E1	4.70		
e	2.186	2.286	2.386
H	9.80	10.10	10.40
L	1.40	1.50	1.70
L1	2.90 REF		
L2	0.90		1.25
L3	0.51 BSC		
L4	0.60	0.80	1.00
L6	1.80 BSC		
θ1	5°	7°	9°
θ2	5°	7°	9°
V2	0°		8°

4.3 DPAK (TO-252) type E package information

Figure 23. DPAK (TO-252) type E package outline

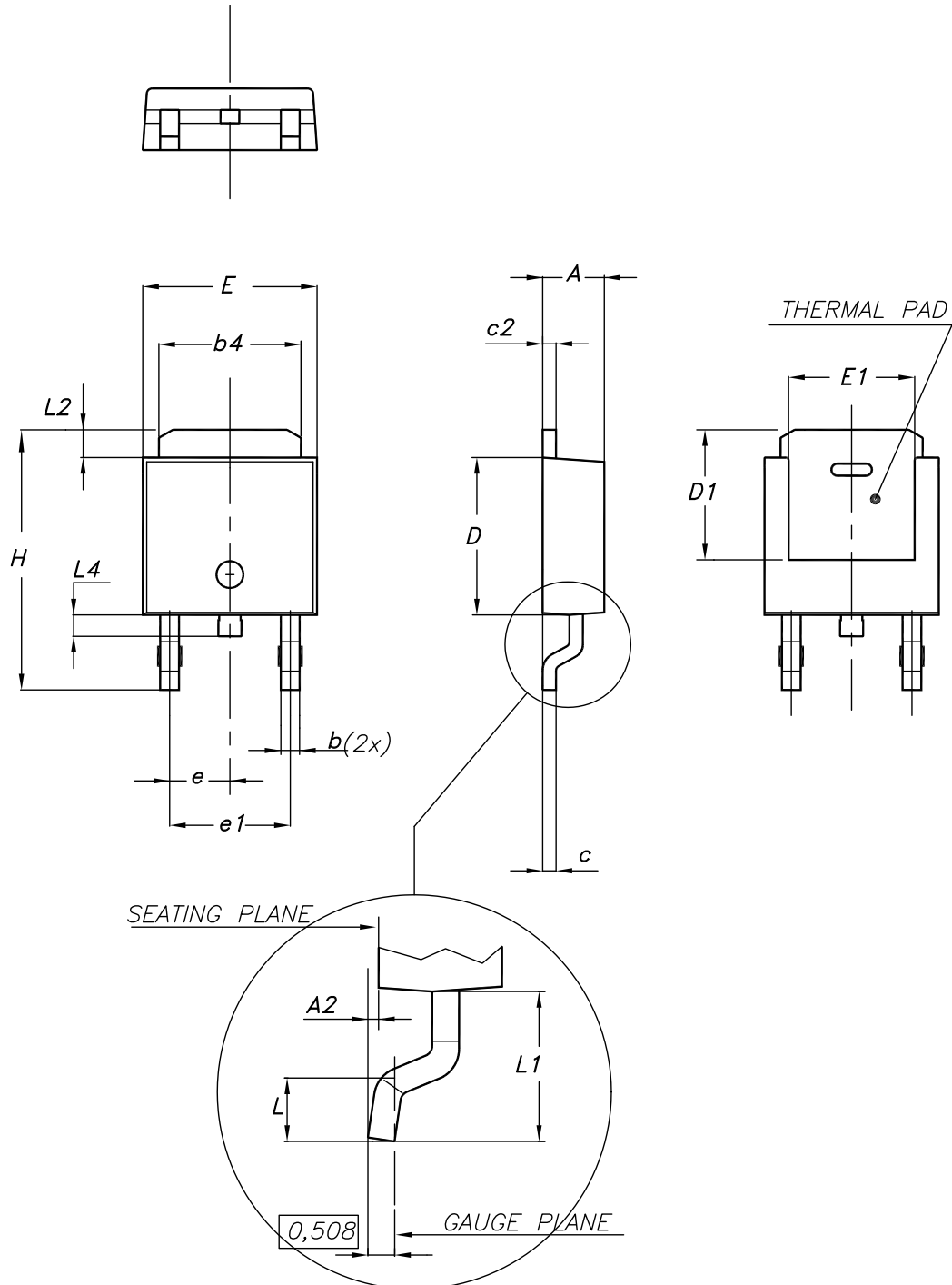

0068772_type-E_rev.25

Table 10. DPAK (TO-252) type E mechanical data

Dim.	mm		
	Min.	Typ.	Max.
A	2.18		2.39
A2			0.13
b	0.65		0.884
b4	4.95		5.46
c	0.46		0.61
c2	0.46		0.60
D	5.97		6.22
D1	5.21		
E	6.35		6.73
E1	4.32		
e		2.286	
e1		4.572	
H	9.94		10.34
L	1.50		1.78
L1		2.74	
L2	0.89		1.27
L4			1.02

Figure 24. DPAK (TO-252) recommended footprint (dimensions are in mm)

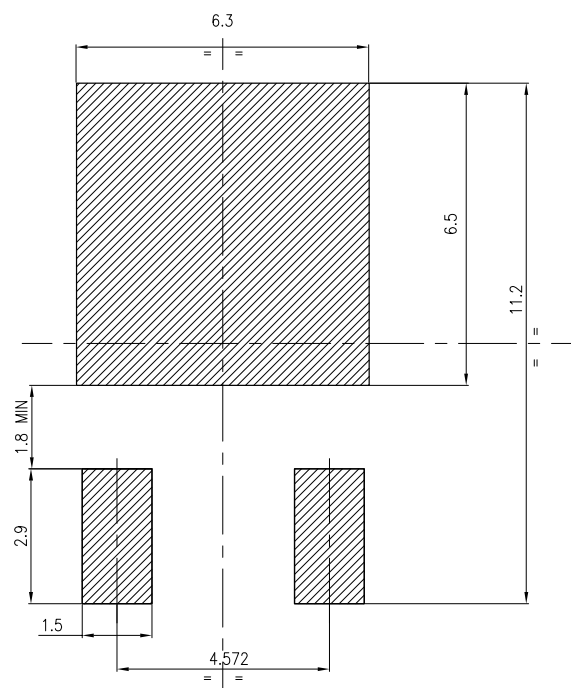

FP_0068772_25

4.4 DPAK (TO-252) packing information

Figure 25. DPAK (TO-252) tape outline

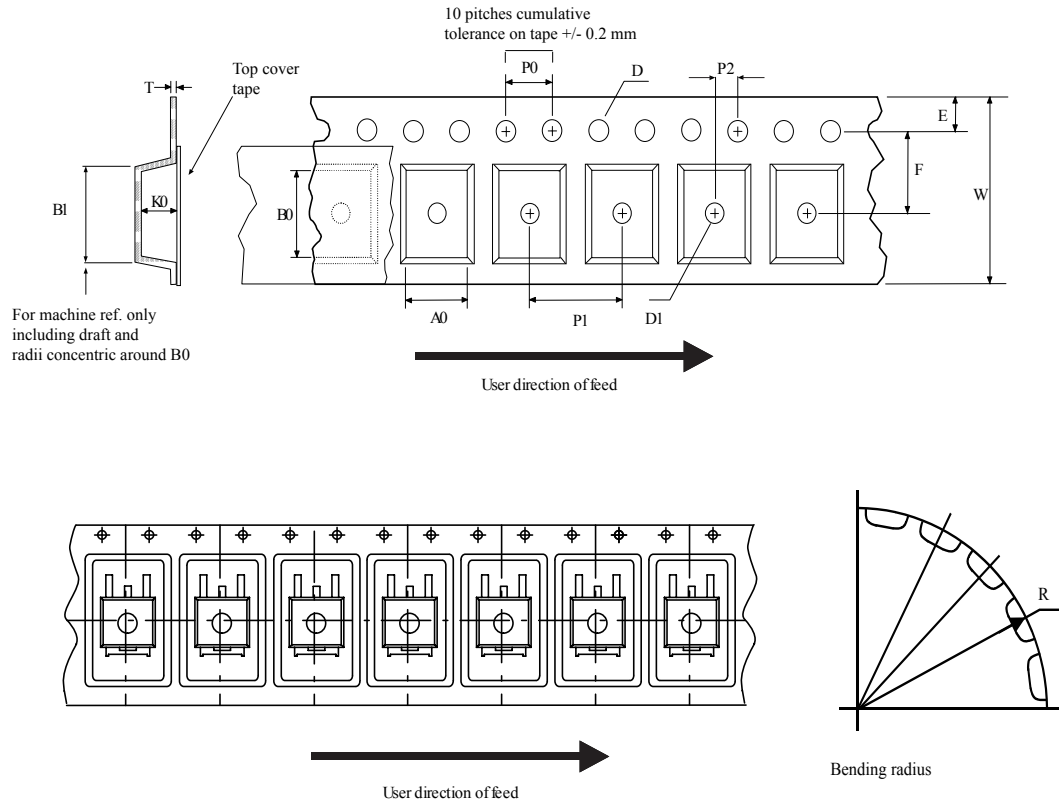

AM08852v1

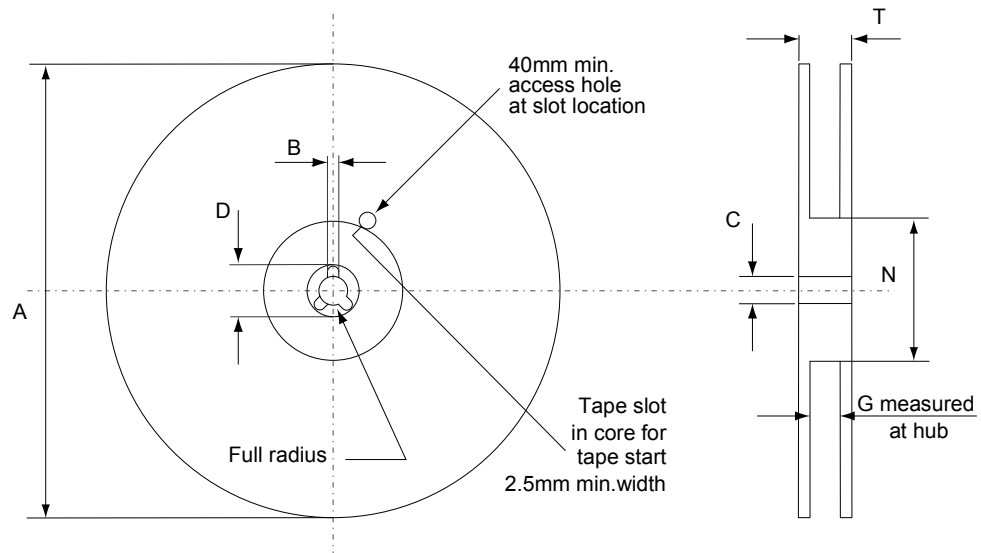
Figure 26. DPAK (TO-252) reel outline

AM06038v1

Table 11. DPAK (TO-252) tape and reel mechanical data

Tape			Reel		
Dim.	mm		Dim.	mm	
	Min.	Max.		Min.	Max.
A0	6.8	7	A		330
B0	10.4	10.6	B	1.5	
B1		12.1	C	12.8	13.2
D	1.5	1.6	D	20.2	
D1	1.5		G	16.4	18.4
E	1.65	1.85	N	50	
F	7.4	7.6	T		22.4
K0	2.55	2.75			
P0	3.9	4.1	Base qty.		2500
P1	7.9	8.1	Bulk qty.		2500
P2	1.9	2.1			
R	40				
T	0.25	0.35			
W	15.7	16.3			

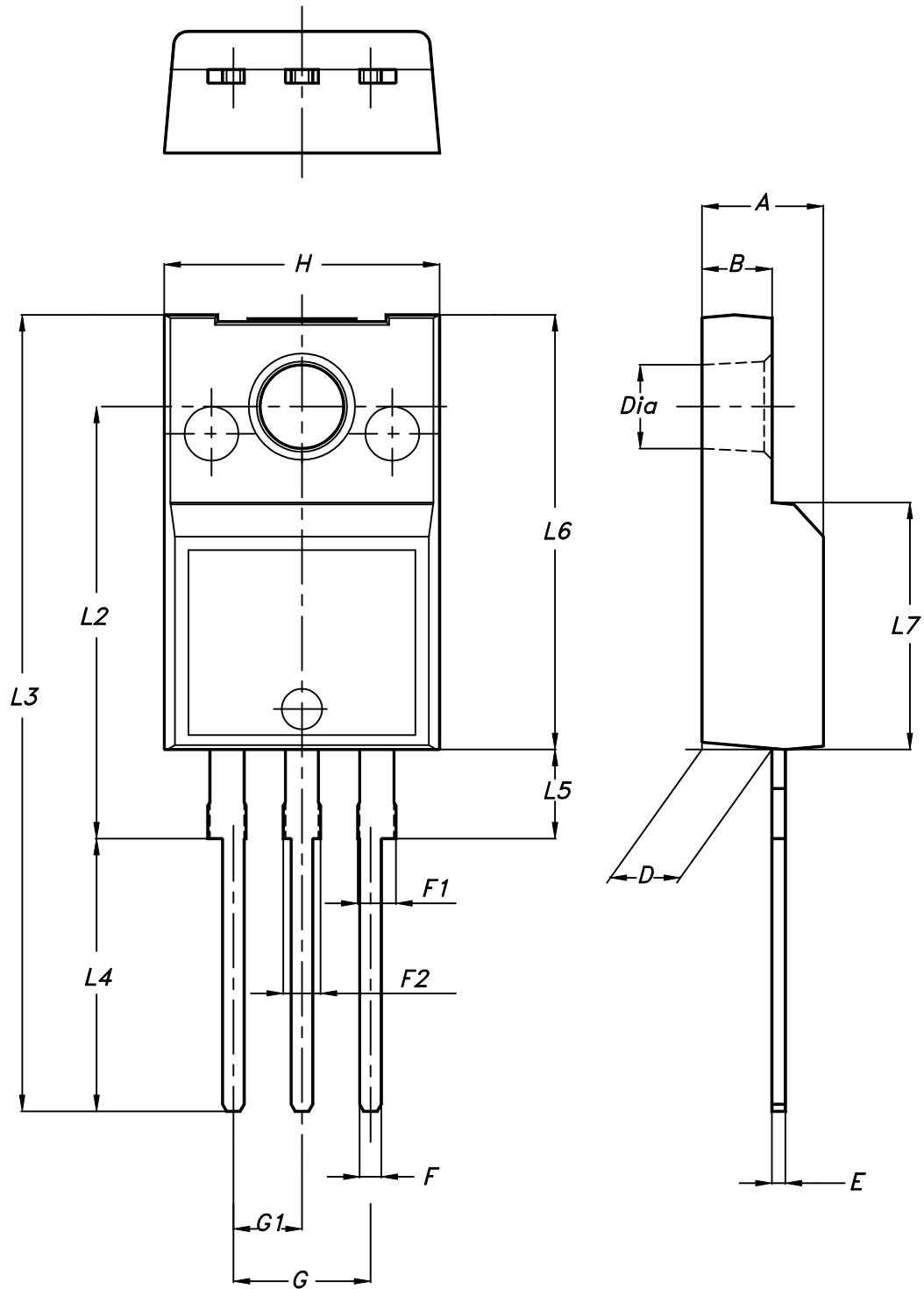
4.5 TO-220FP package information
Figure 27. TO-220FP package outline

7012510_Rev_12_B

Table 12. TO-220FP package mechanical data

Dim.	mm		
	Min.	Typ.	Max.
A	4.4		4.6
B	2.5		2.7
D	2.5		2.75
E	0.45		0.7
F	0.75		1
F1	1.15		1.70
F2	1.15		1.70
G	4.95		5.2
G1	2.4		2.7
H	10		10.4
L2		16	
L3	28.6		30.6
L4	9.8		10.6
L5	2.9		3.6
L6	15.9		16.4
L7	9		9.3
Dia	3		3.2

Revision history

Table 13. Document revision history

Date	Version	Changes
12-Mar-2014	1	First release.
17-Jun-2014	2	<ul style="list-style-type: none"> – Modified: title – Modified: dv/dt values in <i>Table 2</i> – Modified: values in <i>Table 4</i> – Modified: R_{DS(on)} value in <i>Table 5</i> – Modified: the entire typical values in <i>Table 6, 7 and 8</i> – Added: <i>Section 2.1: Electrical characteristics (curves)</i> – Updated: <i>Section 4: Package mechanical data</i> – Minor text changes
26-Oct-2018	3	<p>Removed maturity status indication from cover page. The document status is production data.</p> <p>Modified title, features and description on cover page.</p> <p>Updated Section 4 Package information.</p> <p>Minor text changes.</p>

Contents

1	Electrical ratings	2
2	Electrical characteristics	3
2.1	Electrical characteristics (curves)	5
3	Test circuits	8
4	Package information	9
4.1	DPAK (TO-252) type A package information	9
4.2	DPAK (TO-252) type C package information	11
4.3	DPAK (TO-252) type E package information	13
4.4	DPAK (TO-252) packing information	15
4.5	TO-220FP package information	17
	Revision history	20

IMPORTANT NOTICE – PLEASE READ CAREFULLY

STMicroelectronics NV and its subsidiaries (“ST”) reserve the right to make changes, corrections, enhancements, modifications, and improvements to ST products and/or to this document at any time without notice. Purchasers should obtain the latest relevant information on ST products before placing orders. ST products are sold pursuant to ST’s terms and conditions of sale in place at the time of order acknowledgement.

Purchasers are solely responsible for the choice, selection, and use of ST products and ST assumes no liability for application assistance or the design of Purchasers’ products.

No license, express or implied, to any intellectual property right is granted by ST herein.

Resale of ST products with provisions different from the information set forth herein shall void any warranty granted by ST for such product.

ST and the ST logo are trademarks of ST. All other product or service names are the property of their respective owners.

Information in this document supersedes and replaces information previously supplied in any prior versions of this document.

© 2018 STMicroelectronics – All rights reserved

Looking for pricing, stock, or lifecycle information?

Click below to explore more details on WIN SOURCE:

- ⊖ [View STF11N50M2 on WIN SOURCE](#)
- ⊖ [STMicroelectronics](#) Information

Optimize Your Supply Chain with WIN SOURCE Solutions

- ✓ Global Sourcing Solution
- ✓ Obsolete Management
- ✓ Cost Control Management
- ✓ Shortage Management
- ✓ Alternative Solution
- ✓ Excess Inventory Management