



**THE DATASHEET OF  
ICL7662EBD+**



### General Description

The ICL7662/Si7661 is a monolithic charge pump voltage inverter that will convert a positive voltage in the range of +4.5V to +20V to the corresponding negative voltage of -4.5V to -20V. The ICL7662/Si7661 provides performance far superior to previous implementations of charge pump voltage inverters by combining low quiescent current with high efficiency. The ICL7662/Si7661 has an oscillator, control circuitry, and 4 power MOS switches on-chip, with the only required external components being two low cost capacitors.

### Applications

- Inexpensive Negative Supplies
- Data Acquisition Systems
- Up to -20V for Op Amps, and Other Linear Circuits
- Supply Splitter,  $V_{OUT} = V_s/2$
- RS-232 Power Supplies

### Pin Configurations

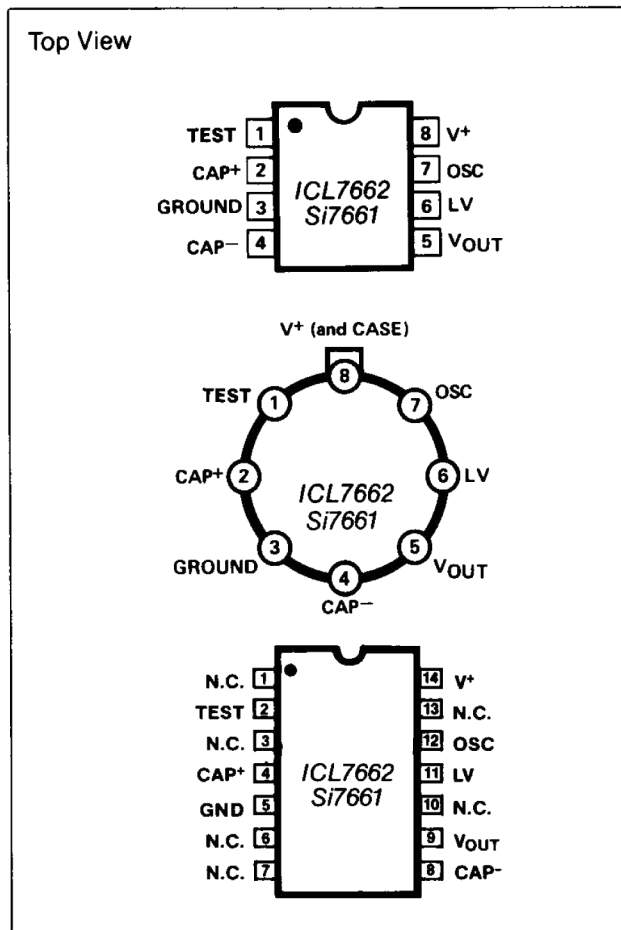

### Features

- ◆ +4.5V to +20V Supply to -4.5V to -20V Output
- ◆ Cascaded Voltage Multiplication ( $V_{OUT} = -n \times V^+$ )
- ◆ 99.7% Typical Open Circuit Conversion Efficiency
- ◆ Requires Only 2 External Capacitors
- ◆ Pin Compatible with the ICL7660

### Ordering Information

PART	TEMP. RANGE	PIN-PACKAGE
ICL7662CPA	0°C to +70°C	8 Plastic DIP
ICL7662CBD	0°C to +70°C	14 SO
ICL7662CBA	0°C to +70°C	8 SO
ICL7662C/D	0°C to +70°C	Dice
ICL7662EPA	-40°C to +85°C	8 Plastic DIP
ICL7662EBD	-40°C to +85°C	14 SO
ICL7662EBA	-40°C to +85°C	8 SO
ICL7662MTV-4	-55°C to +125°C	8 TO-99
ICL7662MJA	-55°C to +125°C	8 CERDIP

Ordering information continued at end of data sheet.

### Typical Operating Circuit

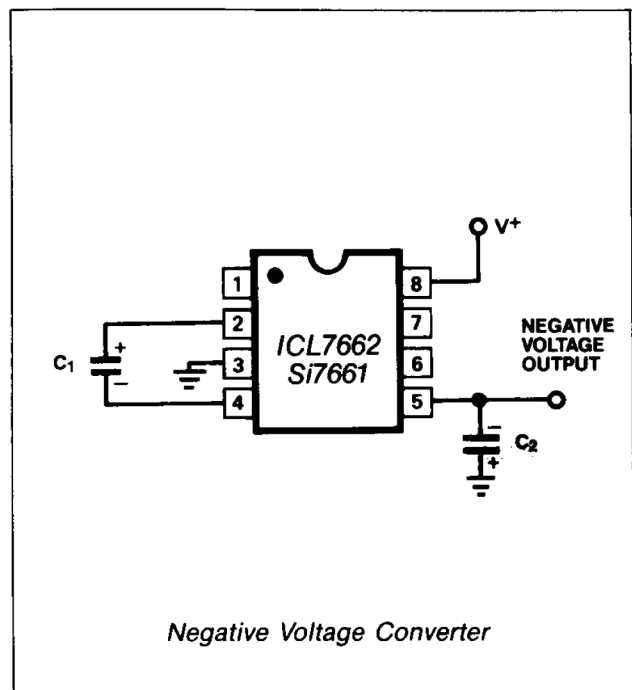

For pricing, delivery, and ordering information, please contact Maxim Direct at 1-888-629-4642, or visit Maxim's website at [www.maxintegrated.com](http://www.maxintegrated.com).

# ICL7662/Si7661

## CMOS Voltage Converters

### ABSOLUTE MAXIMUM RATINGS

V+ TO GND .....	-0.3V, +22V
Oscillator Input to GND (Note 1)	
(V- < 12V).....	-0.3V, V+ + 0.3V
(V+ > 12V).....	V+ - 12.3V, V+ + 0.3V
Power Dissipation (Note 2)	
Plastic DIP .....	300mW
SO .....	500mW
TO-99 .....	500mW
CERDIP .....	500mW

Operating Temperature Ranges	
Commercial (ICL7662C_, Si7661C_).....	0°C to +70°C
Extended (ICL7662E_, Si7661D_ or ESA) .....	-40°C to +85°C
Military (ICL7662MTV/MJA, Si7661AA/AK) .....	-55°C to +125°C
Storage Temperature.....	-65°C to +160°C
Lead Temperature (soldering, 10sec) .....	+300°C

Stresses above those listed under "Absolute Maximum Ratings" may cause permanent damage to the device. These are stress ratings only, and functional operation of the device at these or any other conditions above those indicated in the operational sections of the specifications is not implied. Exposure to absolute maximum rating conditions for extended periods may affect device reliability.

### ELECTRICAL CHARACTERISTICS: ICL7662

(V+ = +15V, T<sub>A</sub> = +25°C, C<sub>OSC</sub> = 0, unless otherwise noted. See Test Circuit Figure 1.)

PARAMETER	SYMBOL	CONDITIONS	MIN	TYP	MAX	UNITS
Supply Voltage Range-Lo	V+ L	R <sub>L</sub> = 10kΩ, LV = GND	-55°C < T <sub>A</sub> < +125°C	4.5	11	V
Supply Voltage Range-Hi	V+ H	R <sub>L</sub> = 10kΩ, LV = Open	-40°C < T <sub>A</sub> < +85°C	9	20	
			-55°C < T <sub>A</sub> < +125°C	9	16.5	
Supply Current	I+	R <sub>L</sub> = ∞, LV = Open	T <sub>A</sub> = +25°C	0.25	0.60	mA
			0°C < T <sub>A</sub> < +70°C	0.30	0.85	
			-55°C < T <sub>A</sub> < +125°C	0.40	1.0	
Output Source Resistance	R <sub>O</sub>	I <sub>O</sub> = 20mA, LV = Open	T <sub>A</sub> = +25°C	60	100	Ω
			0°C < T <sub>A</sub> < +70°C	70	120	
			-55°C < T <sub>A</sub> < +125°C	90	150	
Supply Current	I+	V+ = 5V, R <sub>L</sub> = ∞, LV = GND	T <sub>A</sub> = +25°C	20	150	μA
			0°C < T <sub>A</sub> < +70°C	25	200	
			-55°C < T <sub>A</sub> < +125°C	30	250	
Output Source Resistance	R <sub>O</sub>	V+ = 5V, I <sub>O</sub> = 3mA, LV = GND	T <sub>A</sub> = +25°C	125	200	Ω
			0°C < T <sub>A</sub> < +70°C	150	250	
			-55°C < T <sub>A</sub> < +125°C	200	350	
Oscillator Frequency	f <sub>OSC</sub>			10		kHz
Power Efficiency	P <sub>eff</sub>	R <sub>L</sub> = 2kΩ	T <sub>A</sub> = +25°C	93	96	%
			Min < T <sub>A</sub> < Max	90	95	
Voltage Conversion Efficiency	V <sub>oEf</sub>	R <sub>L</sub> = ∞	Min < T <sub>A</sub> < Max	97	99.9	%
Oscillator Sink or Source Current	I <sub>OSC</sub>	V+ = 5V (V <sub>OSC</sub> = 0V to +5V)		0.5		μA
		V+ = 15V (V <sub>OSC</sub> = +5V to +15V)		4.0		

**Note 1:** Connecting any terminal to voltages greater than V+ or less than ground may cause destructive latchup. It is recommended that no input from sources operating from external supplies be applied prior to power-up of the ICL7662.

**Note 2:** Derate linearly above +50°C by 5.5mW/°C.

**Note 3:** Pin 1 is a test pin and is not connected in normal use.

# ICL7662/Si7661

## CMOS Voltage Converters

### ELECTRICAL CHARACTERISTICS: Si7661

( $V_+ = +15V$ ,  $T_A = +25^\circ C$ ,  $C_{OSC} = 0$ , unless otherwise noted. See Test Circuit Figure 1.)

PARAMETER	SYMBOL	TEST CONDITIONS UNLESS OTHERWISE SPECIFIED: $C_{OSC} = 0$	LIMITS				UNITS
			1 = 25°C		A, B, C, D, E SUFFIX		
			TEMP	TYP	MIN	MAX	
<b>INPUT</b>							
Supply Voltage Range (LV)	$V_{+LV}$	$R_L = 10k\Omega$ , LV = 0V	1, 2, 3		4.5	9	V
Supply Voltage Range	$V_+$	$R_L = 10k\Omega$ , LV = Open	Si7661B, C, D, E 1, 2, 3		8	20	
			Si7661A 1, 2, 3		8	16.5	
Supply Current	$I_+$	$V_+ = 4.5V$ , $R_L = \infty$ , LV = 0V	1			500	$\mu A$
		$V_+ = 4.5V$ , $R_L = \infty$ , LV = Open	1			2	mA
<b>OUTPUT</b>							
Output Source Resistance	$R_{OUT}$	$V_+ = 4.5V$ , LV = 0V, $I_O = 3mA$	1	100			$\Omega$
		$V_+ = 15V$ , LV = Open, $I_O = 20mA$	1, 3	55		100	
			2			120	
Power Conversion Efficiency	PE	$V_+ = 15V$ , $R_L = 2k\Omega$	1	92			%
Voltage Conversion Efficiency	$V_{OUT E}$	$V_+ = 15V$ , $R_L = \infty$	1	99.7	97		
<b>DYNAMIC</b>							
Oscillator Frequency	$f_{OSC}$	$V_+ = 15V$	1	10			kHz
Oscillator Impedance	$Z_{OSC}$	$V_+ = 4.5V$ , LV = 0V	1	1			M $\Omega$
		$V_+ = 15V$	1	100			k $\Omega$

### Typical Operating Characteristics

**UNLOADED OSCILLATOR  
FREQUENCY vs.  
TEMPERATURE**

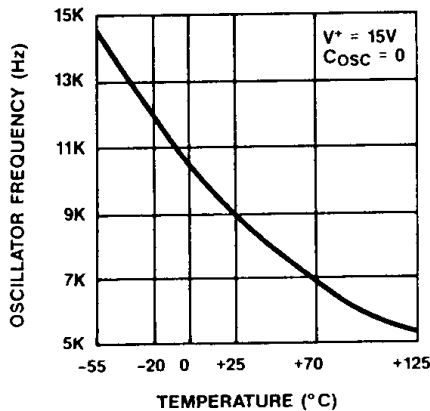

**OUTPUT SOURCE  
RESISTANCE vs.  
SUPPLY VOLTAGE**

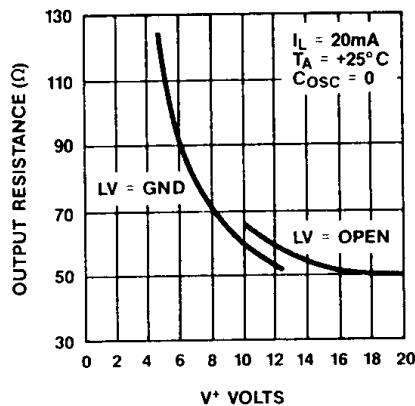

**OUTPUT SOURCE  
RESISTANCE vs.  
TEMPERATURE**

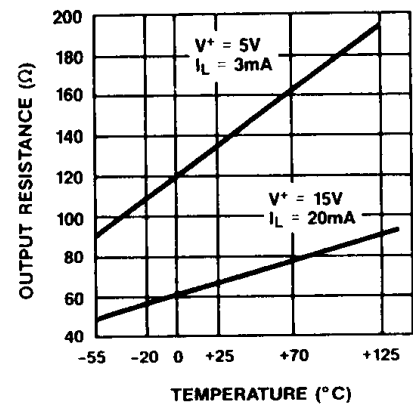

# ICL7662/Si7661

## CMOS Voltage Converters

### Typical Operating Characteristics (continued)

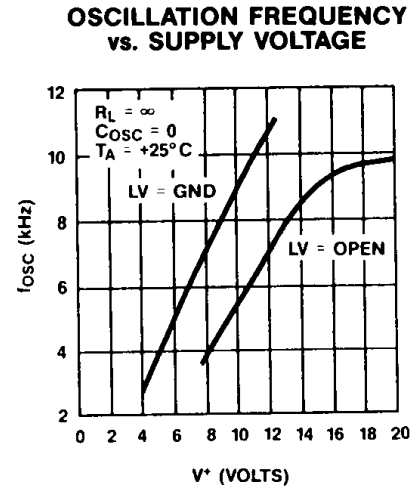
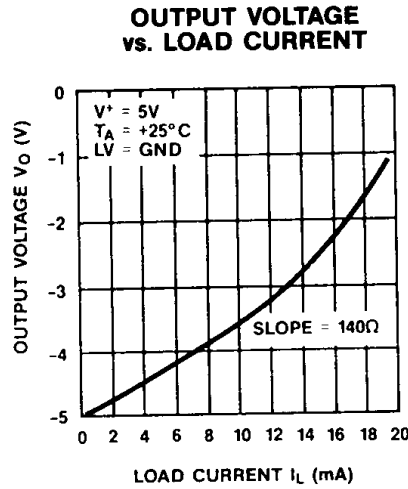
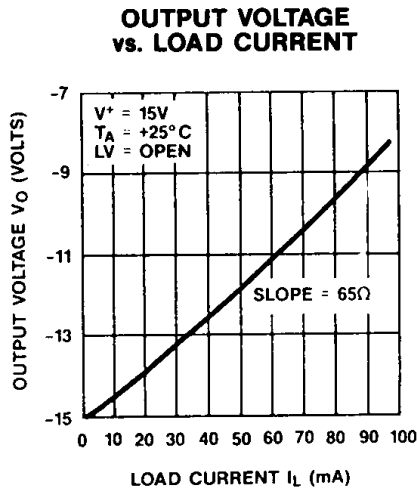

**POWER CONVERSION FREQUENCY AND OUTPUT RESISTANCE vs. OSCILLATOR FREQUENCY**

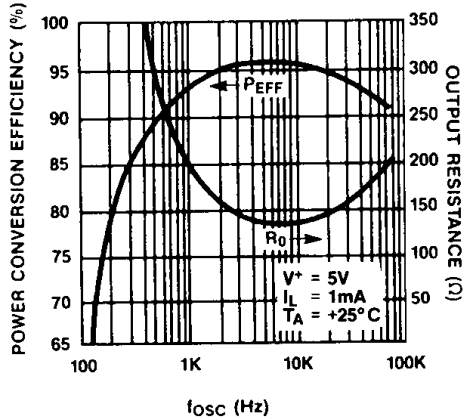

**SUPPLY CURRENT vs. OSCILLATOR FREQUENCY**

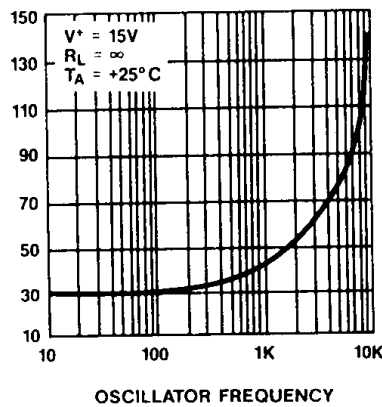

**OSCILLATION FREQUENCY vs. EXTERNAL OSCILLATOR CAPACITANCE**

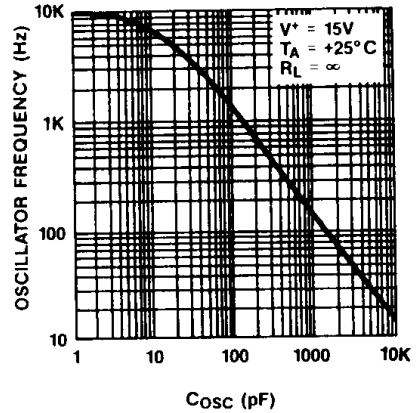

### Detailed Description

All the circuitry necessary to complete a voltage inverter is contained on the ICL7662 (Si7661). Only 2 external capacitors are needed. These may be inexpensive  $10\mu F$  polarized electrolytic capacitors. Figure 2, an idealized voltage inverter, illustrates the ICL7662 (Si7661) operation. During the first half of the cycle, switches S2 and S4 are open; switches S1 and S3 are closed, and the capacitor C1 is charged to a voltage  $V_{IN}$ . During the second half cycle, switches S1 and S3 are opened, and switches S2 and S4 are closed. The capacitor C1 undergoes a negative shift equal to  $V_{IN}$ . Assuming ideal switches ( $R_{ON} = 0$ ) and no load on C2, charge is then transferred from C1 to C2 such that the voltage on C2 is exactly  $-V_{IN}$ .

The four switches in Figure 2 are MOS power switches. Switch S1 is a P channel switch and switches S2, S3 and S4 are N channel devices.

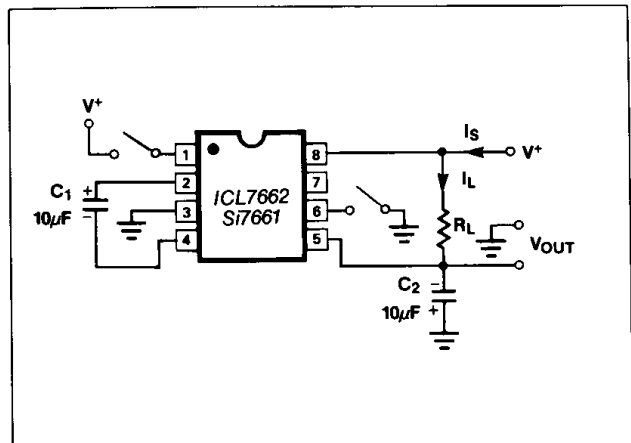

Figure 1. ICL7662/Si7661 Test Circuit

# ICL7662/Si7661

## CMOS Voltage Converters

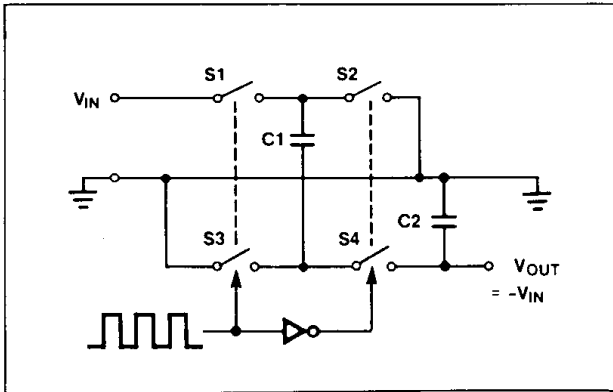

Figure 2. Idealized Negative Voltage Converter

### Efficiency Considerations

Theoretically, a voltage multiplier can approach 100% efficiency if certain conditions are met. The ICL7662 (Si7661) approaches the conditions listed below for negative voltage multiplication if large values of C1 and C2 are used.

- The output switches have virtually no offset and extremely low ON resistance.
- Minimal power is consumed by the drive circuitry.
- The impedances of the reservoir and pump capacitors are negligible.

The energy loss per charge pump cycle is:

$$E = \frac{1}{2} \times C1 \times (V_{IN}^2 - V_{OUT}^2)$$

There will be a substantial voltage difference between  $V_{IN}$  and  $V_{OUT}$  if the impedances of C1 and C2 (at the pump frequency) are high compared to output load  $R1$ . To reduce output ripple, make C2 as large in value as is practical. Increasing the value of both C1 and C2 will improve the efficiency.

### General Precautions

- The positive terminal of C1 must be connected to Pin 2 of the ICL7662 (Si7661), and the positive terminal of C2 must be connected to Ground.
- Never exceed maximum supply voltages.
- For higher efficiency, connect LV to Ground for supply voltages less than 8 volts.
- $V_{OUT}$  should not be shorted to  $V^+$  for extended periods of time. Transient conditions (including startup) are acceptable.

### Applications

#### Changing Oscillator Frequency

Normally the OSC pin of the ICL7662 (Si7661) is left open, and the 10kHz nominal frequency (5kHz charge pump frequency) is used. The oscillator can be lowered by connecting an external capacitor between

OSC and  $V^+$  (see Figure 3). A graph in the Typical Operating Characteristics section shows the nominal frequency versus capacitor value. Lowering the oscillator frequency will improve the conversion efficiency with very low output current values. An undesirable effect of lowering the oscillator frequency is that the impedance level of the pump capacitor will increase. Increasing the value of C1 and C2 will compensate for this effect.

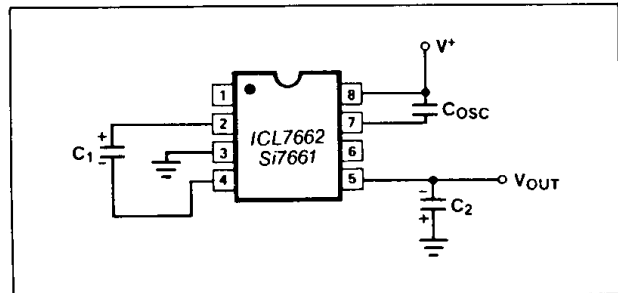

Figure 3. Lowering Oscillator Frequency

In some applications, particularly audio amplifiers, the 5kHz output ripple frequency is objectionable. The oscillator frequency may be increased by one of two methods. The first method is to overdrive the OSC pin with an external oscillator. To eliminate the possibility of latchup, insert a 1kΩ resistor in series with the OSC input (see Figure 4). If the external clock source does not pullup close to  $V^+$ , then a 10kΩ pullup resistor is suggested. The pump frequency, and, therefore, the output ripple will be one-half of the external clock frequency. Driving the ICL7662 (Si7661) with a higher frequency clock will slightly increase the supply current, but allows the use of smaller external capacitors and increases the ripple frequency.

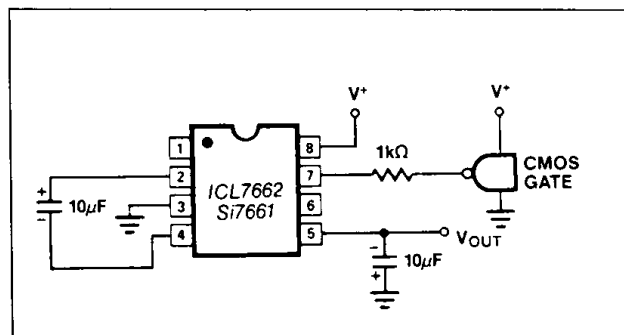

Figure 4. External Clocking

The second method is to tie pin 1 (TEST) to  $V^+$ . This disconnects the internal oscillator from the OSC pin. Since there is always a small amount of parasitic capacitance from the OSC pin, tying the TEST pin to  $V^+$  will allow the capacitor to oscillate faster (depending on how much parasitic capacitance there is from the OSC pin).

# ICL7662/Si7661

## CMOS Voltage Converters

### Cascading Devices

To produce larger negative voltage multiplication of the initial supply voltage, the ICL7662 (Si7661) may be cascaded as shown in Figure 5. The resulting output resistance is approximately equal to the weighted sum of the individual ICL7662 (Si7661)  $R_{OUT}$  values. For light loads, the practical limit is 10 devices. The output voltage is defined by  $V_{OUT} = -n \times V^+$  (where n is an integer representing the number of cascaded devices).

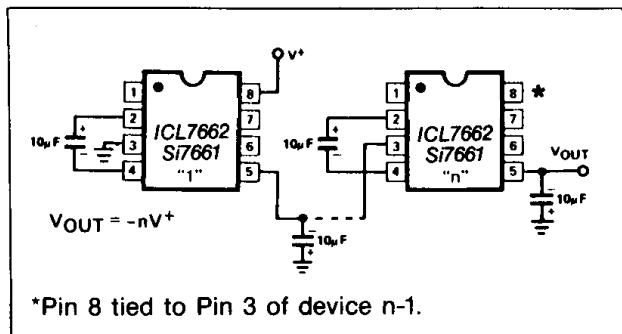

Figure 5. Cascading ICL7662s for Increased Output Voltage

### Negative Voltage Converter

The most common application of the ICL7662 (Si7661) is as a charge pump voltage inverter, converting a positive voltage to the corresponding negative equivalent. The simple circuit of Figure 6 shows that only two external components ( $C_1$  and  $C_2$ ) are needed. In most applications  $C_1$  and  $C_2$  are low cost  $10\mu\text{F}$  electrolytic capacitors. The ICL7662 (Si7661) is NOT a voltage regulator, and the output source resistance is approximately  $60\Omega$  with a  $+15\text{V}$  supply. This means that with an input voltage of  $+15\text{V}$ , the output voltage will be  $-15\text{V}$ , under light loads (less than  $1\text{mA}$  load current), but will decrease to  $-14.4\text{V}$  with a  $10\text{mA}$  load current. The output source impedance of the complete circuit is the sum of the ICL7662 (Si7661) output resistance and the impedance of the pump capacitor at the pump frequency.

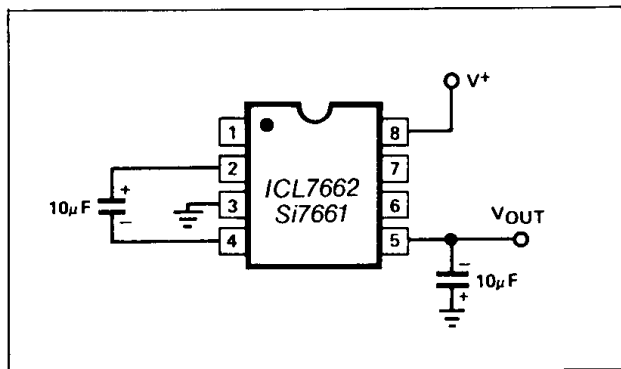

Figure 6. Negative Voltage Converter

The output ripple of the voltage inverter can be calculated by noting that the output current is supplied solely by the reservoir capacitor during one-half of the charge pump cycle. This introduces an output ripple of:

$$V_{RIPPLE} = \frac{1}{2} \times I_{OUT} \times (1/F_{PUMP}) \times (1/C_2)$$

For the nominal  $F_{PUMP}$  of  $5\text{kHz}$  (one-half of the nominal  $10\text{kHz}$  oscillator frequency) and a  $10\mu\text{F}$   $C_2$ , the output ripple will be approximately  $10\text{mV}$  with a load current of  $10\text{mA}$ .

### Positive Voltage Doubler

The ICL7662 (Si7661) can double a positive voltage as shown in Figure 7. It basically uses the ICL7662 (Si7661) as a power inverter. The only drawback from this circuit is the inevitable voltage drop across the two diodes.

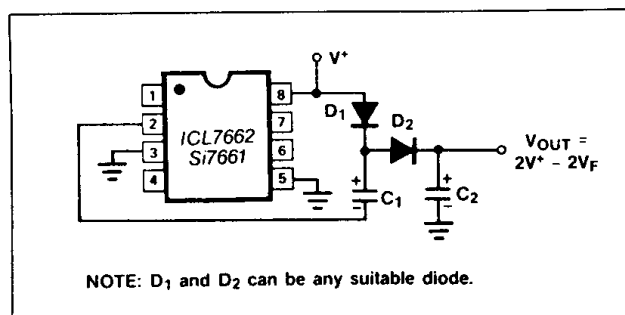

NOTE:  $D_1$  and  $D_2$  can be any suitable diode.

Figure 7. Positive Voltage Doubler

### Paralleling Devices

Paralleling ICL7662s (or Si7661s) reduces the output resistance. As illustrated in Figure 8, each device requires its own pump capacitor  $C_1$ ; however, the reservoir capacitor  $C_2$  serves all devices. The equation for calculating output resistance is also shown in Figure 8.

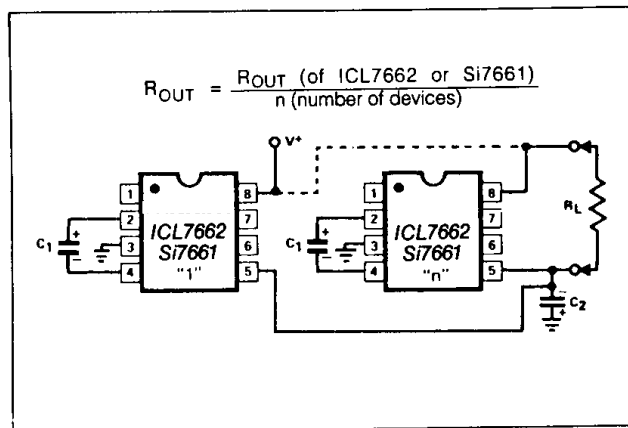

Figure 8. Paralleling ICL7662s to Reduce Output Resistance

# ICL7662/Si7661

## CMOS Voltage Converters

### Combining Positive Supply Multiplication and Negative Voltage Conversion

This dual function is illustrated in Figure 9. In this circuit, capacitors C1 and C3 perform the pump and reservoir functions respectively for the generation of the negative voltage. Capacitors C2 (pump capacitor) and C4 (reservoir capacitor) are used for the positive voltage converter. The circuit configuration, however, does lead to a higher source impedance of the generated supplies. This is due to the finite impedance of the common charge pump driver.

### Voltage Splitting

The ICL7662 (Si7661) can also be used to split a power supply or battery. In Figure 10 the ICL7662 (Si7661) has the positive terminal of the power supply connected to V<sup>+</sup> and the negative terminal connected to V<sub>OUT</sub>. The midpoint of the power supply is found on Pin 3. The output resistance is much lower than in other applications, and higher currents can be drawn from this configuration.

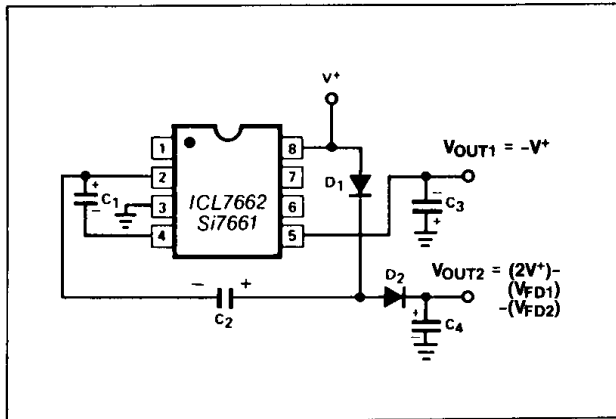

Figure 9. Combined Positive Multiplier and Negative Converter

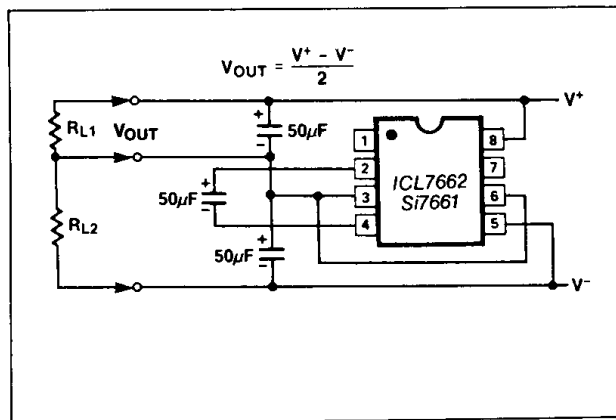
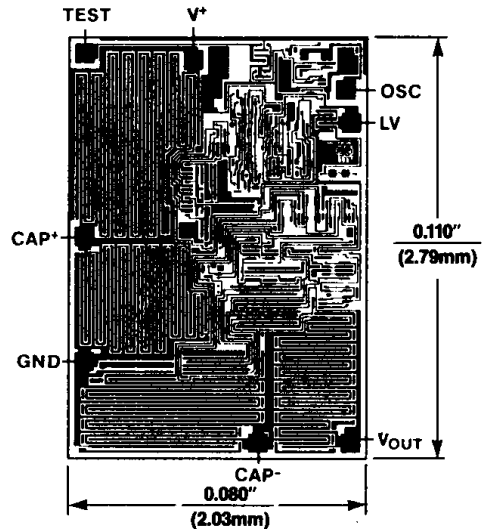

Figure 10. Splitting a Supply in Half

### Chip Topography



### Ordering Information (continued)

PART	TEMP. RANGE	PIN-PACKAGE
Si7661CJ	0°C to +70°C	8 Plastic DIP
Si7661CY	0°C to +70°C	14 SO
Si7661CSA	0°C to +70°C	8 SO
Si7661C/D	0°C to +70°C	Dice
Si7661DJ	-40°C to +85°C	8 Plastic DIP
Si7661DY	-40°C to +85°C	14 SO
Si7661ESA	-40°C to +85°C	8 SO
Si7661AA-4	-55°C to +125°C	8 TO-99
Si7661AK	-55°C to +125°C	8 CERDIP

# ICL7662/Si7661

## CMOS Voltage Converters

### Package Information

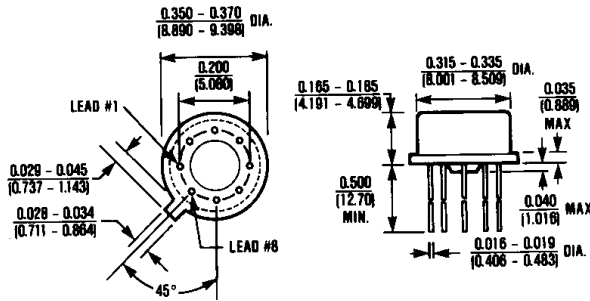

**8 Lead TO-99 (TV)**  
 $\theta_{JA} = 150^{\circ}\text{C/W}$   
 $\theta_{JC} = 45^{\circ}\text{C/W}$

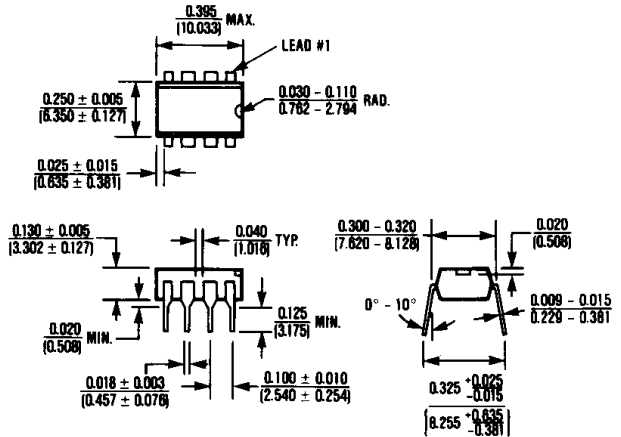

**8 Lead Plastic DIP (PA)**  
 $\theta_{JA} = 160^{\circ}\text{C/W}$   
 $\theta_{JC} = 75^{\circ}\text{C/W}$

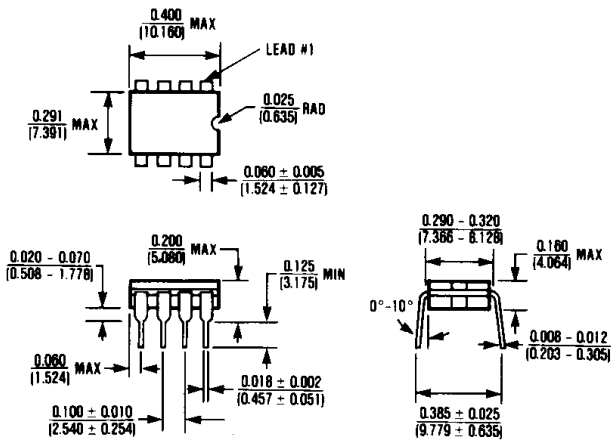

**8 Lead Cerdip (JA)**  
 $\theta_{JA} = 125^{\circ}\text{C/W}$   
 $\theta_{JC} = 55^{\circ}\text{C/W}$

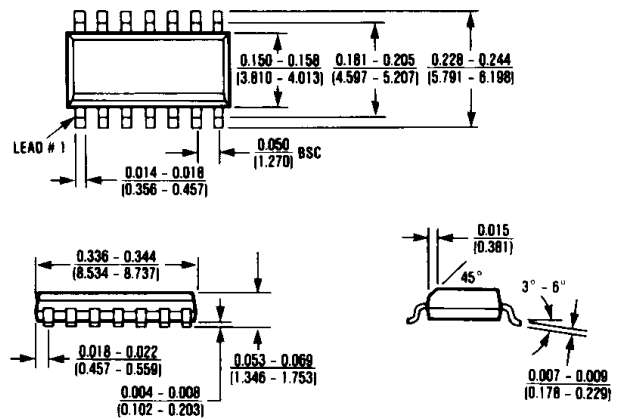

**14 Lead Small Outline (SD)**  
 $\theta_{JA} = 115^{\circ}\text{C/W}$   
 $\theta_{JC} = 60^{\circ}\text{C/W}$



Maxim cannot assume responsibility for use of any circuitry other than circuitry entirely embodied in a Maxim product. No circuit patent licenses are implied. Maxim reserves the right to change the circuitry and specifications without notice at any time. The parametric values (min and max limits) shown in the Electrical Characteristics table are guaranteed. Other parametric values quoted in this data sheet are provided for guidance.

## Looking for pricing, stock, or lifecycle information?

Click below to explore more details on WIN SOURCE:

 [View ICL7662EBD+](#) on WIN SOURCE

 [Maxim Integrated](#) Information

## Optimize Your Supply Chain with WIN SOURCE Solutions

-  Global Sourcing Solution
-  Obsolete Management
-  Cost Control Management
-  Shortage Management
-  Alternative Solution
-  Excess Inventory Management