



**THE DATASHEET OF  
LT1118CS8#TRPBF**



## Low $I_Q$ , Low Dropout, 800mA, Source and Sink Regulators Adjustable and Fixed 2.5V, 2.85V, 5V Output

### FEATURES

- Regulates While Sourcing or Sinking Current
- Provides Termination for up to 27 SCSI Lines
- 600 $\mu$ A Quiescent Current
- Ultralow Power Shutdown Mode
- Current Limit and Thermal Shutdown Protection
- Stable for Any  $C_{LOAD} \geq 0.22\mu$ F
- Fast Settling Time
- 1V Dropout Voltage

### APPLICATIONS

- Active Negation SCSI Terminations
- Computers
- Disk Drives
- CD-ROM
- Supply Splitter

LT, LT, LTC and LTM are registered trademarks of Linear Technology Corporation. All other trademarks are the property of their respective owners.

### DESCRIPTION

The LT<sup>®</sup>1118 family of low dropout regulators has the unique capability of maintaining output regulation while sourcing or sinking load current. The 2.85V output voltage regulator is ideal for use as a Boulay termination of up to 27 SCSI data lines. The regulator maintains regulation while both sourcing and sinking current, enabling the use of active negation drivers for improved noise immunity on the data lines. Regulation of output voltage is maintained for TERMPWR voltages as low as 4.0V. When unloaded, quiescent supply current is a low 600 $\mu$ A, allowing continuous connection to the TERMPWR lines. An ultralow power shutdown mode is also available on the SO-8 version. In Shutdown the output is high impedance and supply current drops to less than 10 $\mu$ A.

Current limits in both sourcing and sinking modes, plus on-chip thermal shutdown make the circuit tolerant of output fault conditions.

The LT1118 is available in 3-lead SOT-223 and 8-lead SO packages.

### TYPICAL APPLICATION

Load Transient Response

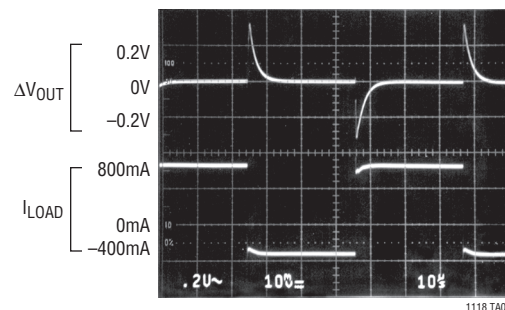
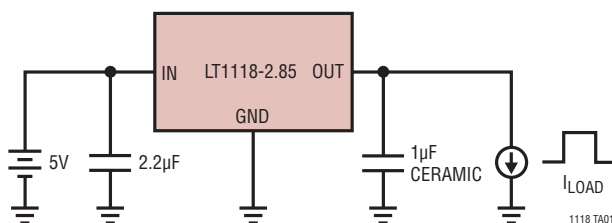

# LT1118/LT1118-2.5/ LT1118-2.85/LT1118-5

## ABSOLUTE MAXIMUM RATINGS (Note 1)

Supply Voltage ( $V_{CC}$ ) .....	15V	Operating Temperature Range.....	0°C to 70°C
Input Voltage (Enable).....	-0.2V to 7V	Storage Temperature Range.....	-65°C to 150°C
Output Voltage .....	-0.2V to $V_{CC} + 0.5V$	Lead Temperature (Soldering, 10 sec) .....	300°C
Short-Circuit Duration .....	Indefinite		

## PIN CONFIGURATION

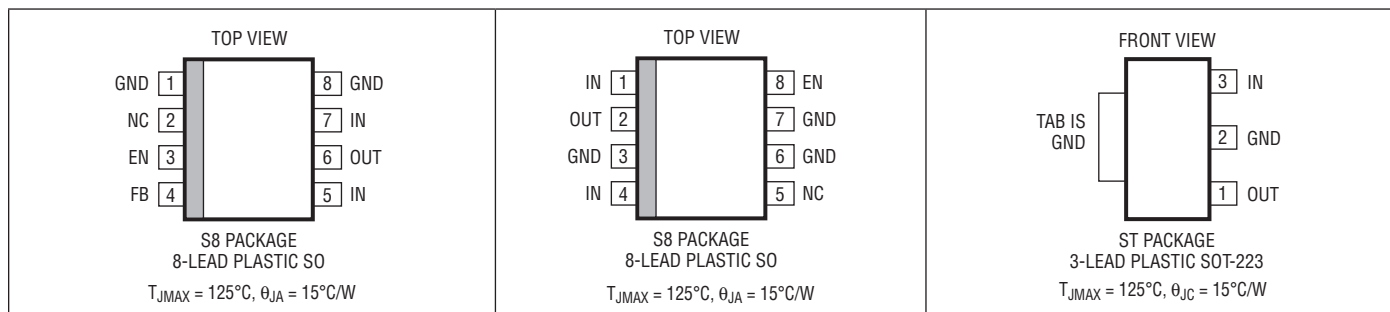

## ORDER INFORMATION

LEAD FREE FINISH	TAPE AND REEL	PART MARKING	PACKAGE DESCRIPTION	TEMPERATURE RANGE
LT1118CS8#PBF	LT1118CS8#TRPBF	1118	8-Lead Plastic SO	0°C to 70°C
LT1118CS8-2.5#PBF	LT1118CS8-2.5#TRPBF	111825	8-Lead Plastic SO	0°C to 70°C
LT1118CS8-2.85#PBF	LT1118CS8-2.85#TRPBF	111828	8-Lead Plastic SO	0°C to 70°C
LT1118CS8-5#PBF	LT1118CS8-5#TRPBF	11185	8-Lead Plastic SO	0°C to 70°C
LT1118CST-2.5#PBF	LT1118CST-2.5#TRPBF	111825	3-Lead Plastic SOT-223	0°C to 70°C
LT1118CST-2.85#PBF	LT1118CST-2.85#TRPBF	111828	3-Lead Plastic SOT-223	0°C to 70°C
LT1118CST-5#PBF	LT1118CST-5#TRPBF	11185	3-Lead Plastic SOT-223	0°C to 70°C
LEAD BASED FINISH	TAPE AND REEL	PART MARKING*	PACKAGE DESCRIPTION	TEMPERATURE RANGE
LT1118CS8	LT1118CS8#TR	1118	8-Lead Plastic SO	0°C to 70°C
LT1118CS8-2.5	LT1118CS8-2.5#TR	111825	8-Lead Plastic SO	0°C to 70°C
LT1118CS8-2.85	LT1118CS8-2.85#TR	111828	8-Lead Plastic SO	0°C to 70°C
LT1118CS8-5	LT1118CS8-5#TR	11185	8-Lead Plastic SO	0°C to 70°C
LT1118CST-2.5	LT1118CST-2.5#TR	111825	3-Lead Plastic SOT-223	0°C to 70°C
LT1118CST-2.85	LT1118CST-2.85#TR	111828	3-Lead Plastic SOT-223	0°C to 70°C
LT1118CST-5	LT1118CST-5#TR	11185	3-Lead Plastic SOT-223	0°C to 70°C

Consult LTC Marketing for parts specified with wider operating temperature ranges.

For more information on lead free part marking, go to: <http://www.linear.com/leadfree/>

For more information on tape and reel specifications, go to: <http://www.linear.com/tapeandreeel/>

**ELECTRICAL CHARACTERISTICS** The ● denotes the specifications which apply over the full operating temperature range, otherwise specifications are at  $T_A = 25^\circ\text{C}$ . (Note 2)

PARAMETER	CONDITIONS	MIN	TYP	MAX	UNITS
Quiescent Current ( $V_{IN}$ )	$V_{EN} = 5V$ ●		0.6	1	mA
Quiescent Current in Shutdown ( $V_{IN}$ )	$V_{EN} = 0V$ ●		1	10	$\mu\text{A}$
Enable Input Thresholds	Input Low Level ●	0.4	1.4		V
	Input High Level ●		1.4	2	V
Enable Input Current	$0V \leq V_{EN} \leq 5V$ ●	-1		25	$\mu\text{A}$
Feedback Voltage	No Load ( $25^\circ\text{C}$ ) (LT1118)	1.213	1.225	1.237	V
	All Operating Conditions (Note 3) ●	1.200	1.225	1.250	V
Output Voltage	No Load ( $25^\circ\text{C}$ ) (LT1118-2.5)	2.47	2.5	2.53	V
	All Operating Conditions (Note 3) ●	2.45	2.5	2.55	V
	No Load ( $25^\circ\text{C}$ ) (LT1118-2.85)	2.82	2.85	2.88	V
	All Operating Conditions (Note 3) ●	2.79	2.85	2.91	V
Line Regulation (Note 4)	No Load ( $25^\circ\text{C}$ ) (LT1118-5)	4.95	5	5.05	V
	All Operating Conditions (Note 3) ●	4.90	5	5.10	V
	$I_L = 0\text{mA}$ , $4.2V \leq V_{IN} \leq 15V$ (LT1118) ●			6	mV
	$I_L = 0\text{mA}$ , $4.2V \leq V_{IN} \leq 15V$ (LT1118-2.5) ●			6	mV
Load Regulation (Note 4)	$I_L = 0\text{mA}$ , $4.75V \leq V_{IN} \leq 15V$ (LT1118-2.85) ●			6	mV
	$I_L = 0\text{mA}$ , $6.5V \leq V_{IN} \leq 15V$ (LT1118-5) ●			10	mV
	$0\text{mA} \leq I_L \leq 800\text{mA}$ (LT1118) ●			6	mV
	$-400\text{mA} \leq I_L \leq 0\text{mA}$ ●			6	mV
Dropout Voltage (Note 5)	$0\text{mA} \leq I_L \leq 800\text{mA}$ (LT1118-2.5) ●			12	mV
	$-400\text{mA} \leq I_L \leq 0\text{mA}$ ●			12	mV
	$0\text{mA} \leq I_L \leq 800\text{mA}$ (LT1118-2.85) ●			12	mV
	$-400\text{mA} \leq I_L \leq 0\text{mA}$ ●			12	mV
Dropout Voltage (Note 5)	$0\text{mA} \leq I_L \leq 800\text{mA}$ (LT1118-5) ●			25	mV
	$-400\text{mA} \leq I_L \leq 0\text{mA}$ ●			25	mV
Dropout Voltage (Note 5)	$I_L = 100\text{mA}$		0.85	1.1	V
	$I_L = 800\text{mA}$		1	1.3	V
FB Pin Bias Current	LT1118		0.35	1	$\mu\text{A}$
Minimum Output Voltage	LT1118 ●			2.1	V
Ripple Rejection	$f_{\text{RIPPLE}} = 120\text{Hz}$ , $V_{IN} - V_{OUT} = 2V$ $V_{\text{RIPPLE}} = 0.5V_{P-P}$	60	80		dB
Load Transient Settling Time, $\Delta V = 1\%$	$0\text{mA} \leq I_L \leq 800\text{mA}$ , $C_{\text{LOAD}} = 1\mu\text{F}$		5		$\mu\text{s}$
	$-400\text{mA} \leq I_L \leq 0\text{mA}$ , $C_{\text{LOAD}} = 1\mu\text{F}$		5		$\mu\text{s}$
Output Short-Circuit Current	$V_{OUT} = 0V$ , Sourcing	800	1200		mA
	$V_{OUT} = V_{IN}$ , Sinking		-700	-400	mA
Thermal Shutdown Junction Temperature	No Load		170		$^\circ\text{C}$
Enable Turn-On Delay	No Load		50		$\mu\text{s}$

**Note 1:** Stresses beyond those listed under Absolute Maximum Ratings may cause permanent damage to the device. Exposure to any Absolute Maximum Rating condition for extended periods may affect device reliability and lifetime.

**Note 2:** Unless otherwise specified, testing done at  $V_{CC} = 5V$  (LT1118-2.5, LT1118-2.85) or  $V_{CC} = 7V$  (LT1118-5).  $V_{EN} = V_{CC}$ . Output  $C_{\text{LOAD}} = 1\mu\text{F}$ ,  $I_{\text{LOAD}} = 0$ .

**Note 3:** All operating conditions include the combined effects of load current, input voltage and temperature over each parameter's full range.

**Note 4:** Load and line regulation are tested at a constant junction temperature by low duty cycle pulse testing.

**Note 5:** Dropout voltage is defined as the minimum input to output voltage measured while sourcing the specified current.

## TYPICAL PERFORMANCE CHARACTERISTICS

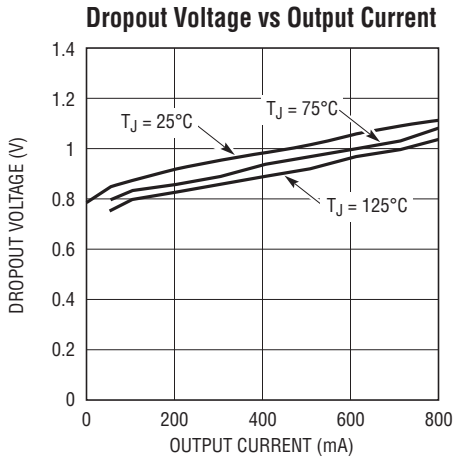

1118 G01

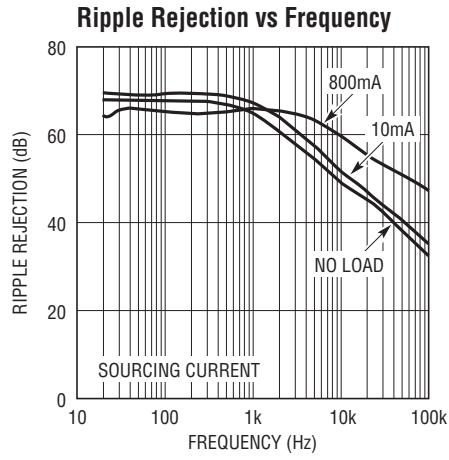

1118 G02

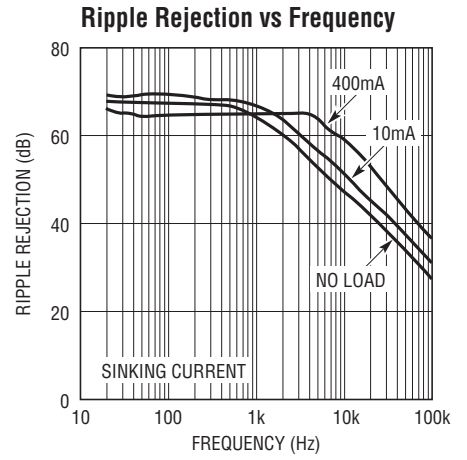

1118 G03

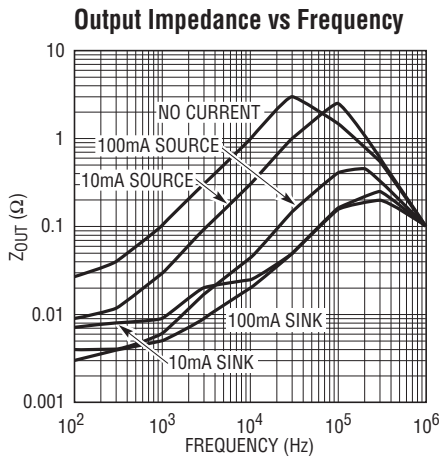

1118 G04

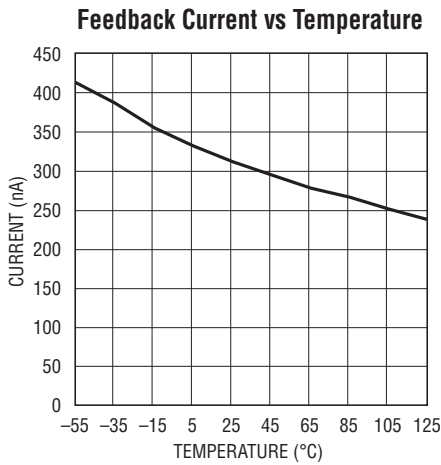

1118 G05

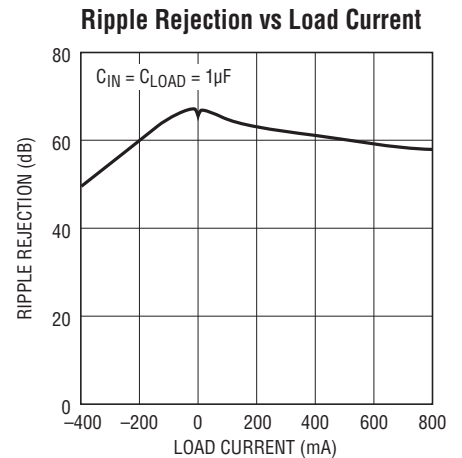

1118 G06

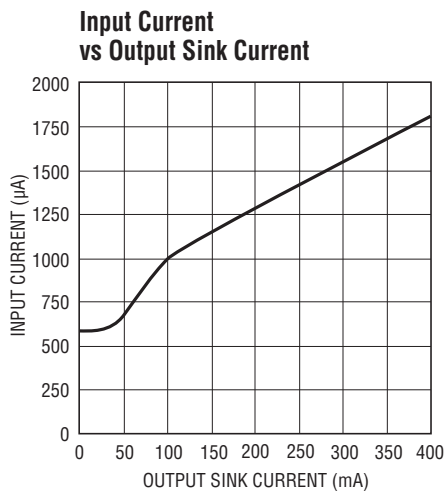

1118 G07

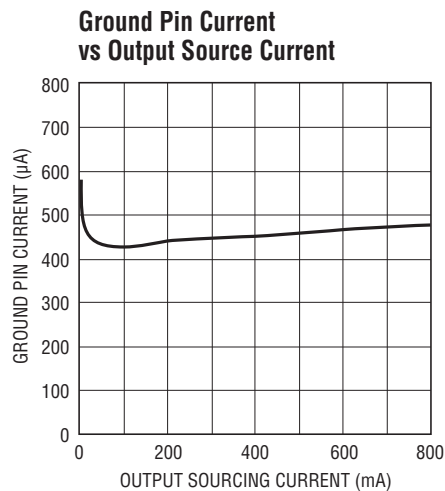

1118 G08

## PIN FUNCTIONS

**IN:** Input Supply Pin. This pin should be decoupled with a 1μF or larger low ESR capacitor. The two IN pins on the SO-8 package must be directly connected on the printed circuit board to prevent voltage drops between the two inputs. When used as a SCSI active termination, IN connects to term power. When used as a supply splitter, IN is also the positive supply output.

**GND:** Ground Pin. The multiple GND pins on the SO-8 package are internally connected, but lowest load regulation errors will result if these pins are tightly connected on the printed circuit board. This will also aid heat dissipation at high power levels.

**EN:** TTL/CMOS Logic Input. A high level allows normal operation. A low level reduces supply current to zero. This pin is internally connected to V<sub>IN</sub> on 3-lead ST packaged devices.

**OUT:** Regulated Output Voltage. Output can source or sink current. Current limit for sourcing and sinking current is provided to protect the device from fault conditions. The output must have a low ESR output filter capacitor. C<sub>OUT</sub> ≥ 0.22μF to guarantee stability. A 0.1μF ceramic capacitor may be needed in parallel with C<sub>OUT</sub> if the ESR of the main C<sub>OUT</sub> is too high.

**FB:** Feedback Pin. The feedback pin is used to program the output voltage of the adjustable S8 part. The output voltage range that can be achieved is 2.1V to 6.5V. The output voltage is determined by the selection of feedback resistors defined by the following formula:

$$V_{OUT} = V_{FB} \left( 1 + \frac{R_1}{R_2} \right) + I_{FB} R_1$$

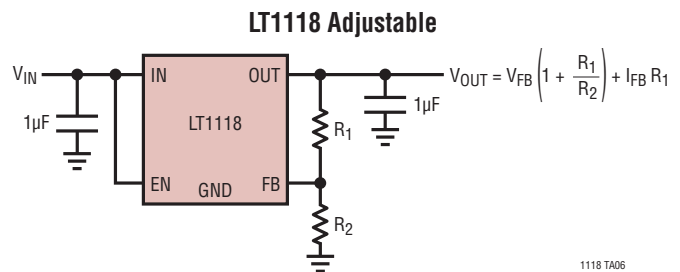

## OPERATION

### Output Capacitor

The LT1118 family of voltage regulators require an output capacitor for stability. The regulators are stable with output capacitors larger than 0.2μF. Load transient response is very sensitive to output capacitor value and dielectric choice. Low ESR ceramic capacitors are the best choice for fast settling to load transients. Output capacitors between 0.2μF and 1μF give good performance in most applications. Larger tantalum output capacitors may be used to reduce load transient amplitudes. Larger capacitors should be paralleled with a 0.1μF ceramic capacitor to maintain quick settling time performance and to insure stability of the regulator control loop. Capacitors larger than 10μF may be safely used with the regulators, but little transient settling performance improvement results from their use.

Worst case transient response of the LT1118 regulators occurs at zero output current. In order to obtain the fastest transient settling performance, the regulator output may be preloaded with a small current. The preload current reduces the regulator output impedance, reducing output voltage settling time.

### Thermal Considerations

The LT1118 regulators are packaged in plastic SOT-223 and fused lead S8 packages. These small footprint packages are unable to convectively dissipate the heat generated when the regulator is operating at high current levels. In order to control die operating temperatures, the PC board layout should allow for maximum possible copper area at the ground pins of the LT1118. The ground pins and the tab on the SOT-223 package are electrically and thermally

# LT1118/LT1118-2.5/ LT1118-2.85/LT1118-5

## OPERATION

connected to the die substrate. Table 1 shows measured thermal resistance from junction to ambient for the LT1118 connected to various sized PC board ground planes. The power dissipated in the LT1118 varies with input voltage and loading. When the regulator is sourcing current the power which must be dissipated by the package is:

$$P_D = (V_{IN} - V_{OUT}) \cdot I_{LOAD}$$

When the regulator is sinking load current, power dissipation is nearly independent of  $V_{IN}$  and can be calculated as:

$$P_D = V_{OUT} \cdot I_{LOAD}$$

Heat sinking to the IC package must consider the worst case power dissipation which may occur.

**Table 1. Measured Thermal Resistance from Junction to Ambient for the LT1118**

	S8 Package	SOT-223
Free Air	120°C/W	95°C/W
1 Sq Inch Copper	55°C/W	53°C/W
4 Sq Inch Copper	35°C/W	38°C/W

## TYPICAL APPLICATIONS

### SCSI Active Terminator

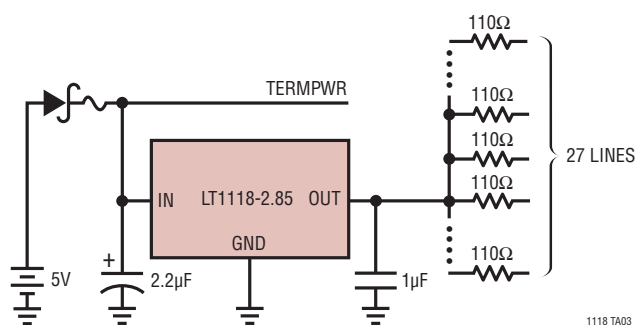

### Power Supply Splitter

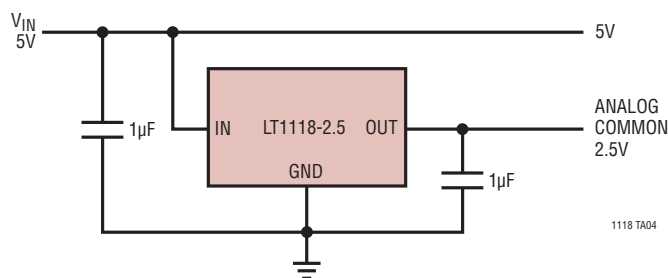

## PACKAGE DESCRIPTION

### ST Package 3-Lead Plastic SOT-223 (Reference LTC DWG # 05-08-1630)

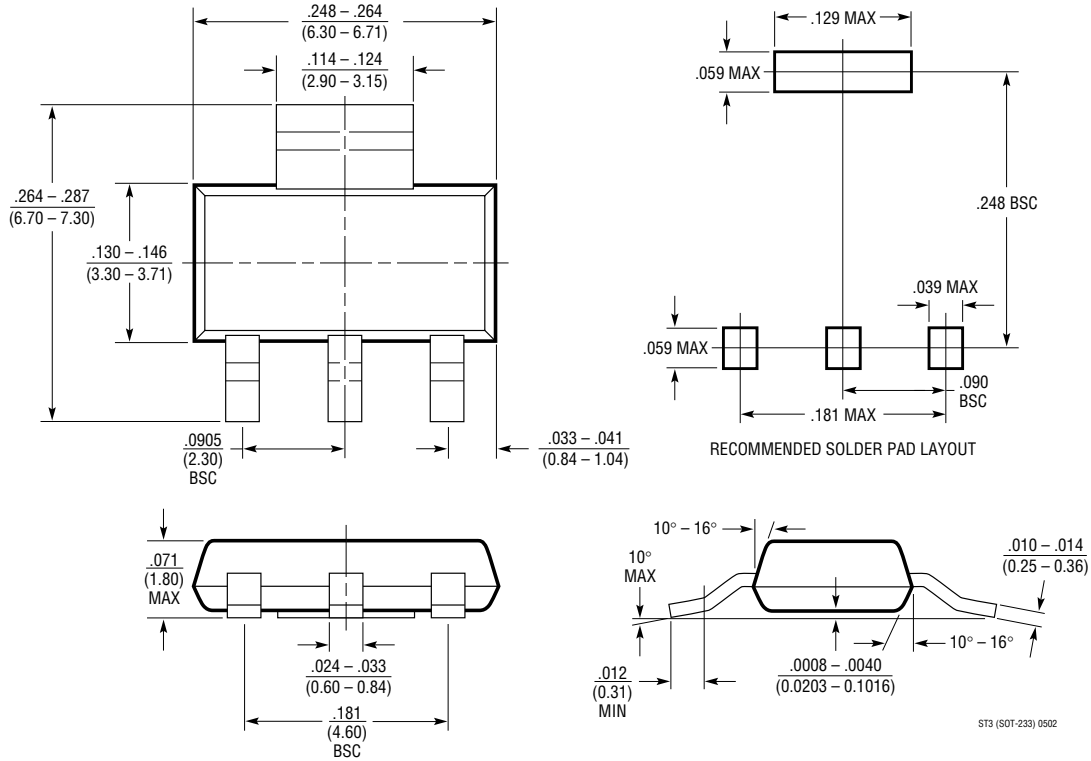

### S8 Package 8-Lead Plastic Small Outline (Narrow 0.150) (Reference LTC DWG # 05-08-1610)

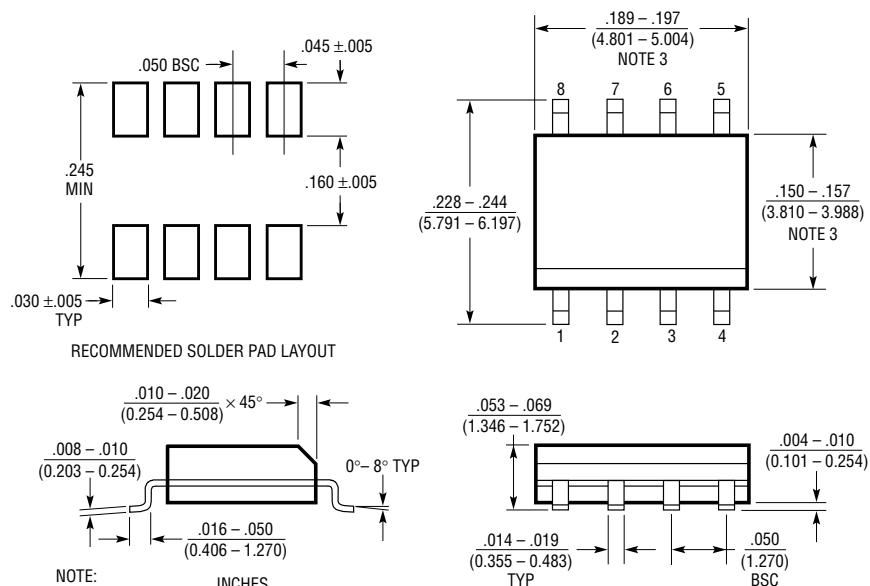

# LT1118/LT1118-2.5/ LT1118-2.85/LT1118-5

## TYPICAL APPLICATION

### Variable 2.1V to 6.5V Regulator with Digital Control

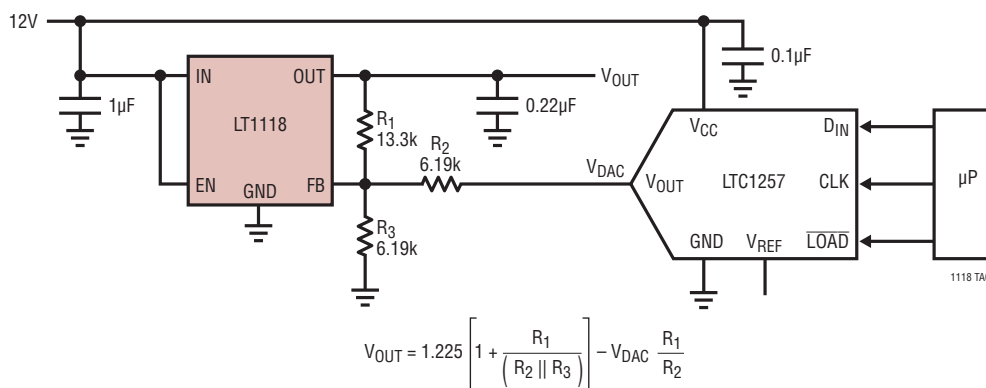

## RELATED PARTS

PART NUMBER	DESCRIPTION	COMMENTS
LT1129	700mA, Micropower, LDO	V <sub>IN</sub> : 4.2V to 30V, V <sub>OUT(MIN)</sub> = 3.8V, V <sub>DO</sub> = 0.40V, I <sub>Q</sub> = 50µA, I <sub>SD</sub> = 16µA; DD, SOT-223, S8, TO220-5 and TSSOP20 Packages
LT1206	250mA/60MHz Current Feedback Amplifier	High Output Current Drive Capability, Can Sink/Source
LT1210	1.1A, 35MHz Current Feedback Amplifier	High Output Current Drive Capability, Can Sink/Source
LT1763	500mA, Low Noise Micropower, LDO	V <sub>IN</sub> : 1.8V to 20V, V <sub>OUT(MIN)</sub> = 1.22V, V <sub>DO</sub> = 0.30V, I <sub>Q</sub> = 30µA, I <sub>SD</sub> = < 1µA, Low Noise < 20µV <sub>RMS</sub> , S8 Package
LT1764/ LT1764A	3A, Low Noise, Fast Transient Response, LDO	V <sub>IN</sub> : 2.7V to 20V, V <sub>OUT(MIN)</sub> = 1.21V, V <sub>DO</sub> = 0.34V, I <sub>Q</sub> = 1mA, I <sub>SD</sub> = < 1µA, Low Noise < 40µV <sub>RMS</sub> , "A" Version Stable with Ceramic Capacitors, DD and TO220-5 Packages
LTC1844	150mA, Very Low Drop-Out LDO	V <sub>IN</sub> : 1.6V to 6.5V, V <sub>OUT(MIN)</sub> = 1.25V, V <sub>DO</sub> = 0.08V, I <sub>Q</sub> = 35µA, I <sub>SD</sub> = < 1µA, Low Noise < 60µV <sub>RMS</sub> , ThinSOT™ Package
LT1962	300mA, Low Noise Micropower, LDO	V <sub>IN</sub> : 1.8V to 20V, V <sub>OUT(MIN)</sub> = 1.22V, V <sub>DO</sub> = 0.27V, I <sub>Q</sub> = 30µA, I <sub>SD</sub> = < 1µA, Low Noise < 20µV <sub>RMS</sub> , MS8 Package
LT1963/ LT1963A	1.5A, Low Noise, Fast Transient Response, LDO	V <sub>IN</sub> : 2.1V to 20V, V <sub>OUT(MIN)</sub> = 1.21V, V <sub>DO</sub> = 0.34V, I <sub>Q</sub> = 1mA, I <sub>SD</sub> = < 1µA, Low Noise < 40µV <sub>RMS</sub> , "A" Version Stable with Ceramic Capacitors; DD, TO220-5, SOT-223 and S8 Packages
LT3021	500mA, Low Voltage V <sub>DO</sub> , V <sub>IN(MIN)</sub> = 0.9V, LDO	V <sub>IN</sub> : 0.9V to 10V, V <sub>OUT(MIN)</sub> = 0.20V, V <sub>DO</sub> = 0.16V, I <sub>Q</sub> = 120µA, I <sub>SD</sub> = 3µA, DFN and S8 Packages
LT3024	Dual, 100mA/500mA, Low Noise Micropower, LDO	V <sub>IN</sub> : 1.8V to 20V, V <sub>OUT(MIN)</sub> = 1.22V, V <sub>DO</sub> = 0.30V, I <sub>Q</sub> = 60µA, I <sub>SD</sub> = < 1µA, DFN and TSSOP Packages
LT3028	Dual, 100mA/500mA, Low Noise Micropower, LDO with Independent Inputs	V <sub>IN</sub> : 1.8V to 20V, V <sub>OUT(MIN)</sub> = 1.22V, V <sub>DO</sub> = 0.30V, I <sub>Q</sub> = 30µA, I <sub>SD</sub> = < 1µA, Low Noise < 20µV <sub>RMS</sub> , DFN and TSSOP Packages
LT3080/ LT3080-1	1.1A Parallelable, Low Noise, Low Dropout Linear Regulator	300mV Dropout Voltage (2-Supply Operation), Low Noise: 40µV <sub>RMS</sub> , V <sub>IN</sub> : 1.2V to 36V, V <sub>OUT</sub> : 0V to 35.7V, Current-Based Reference with 1-Resistor V <sub>OUT</sub> Set; Directly Parallelable (No Op Amp Required), Stable with Ceramic Caps, TO-220, SOT-223, MSOP and 3mm × 3mm DFN Packages; LT3080-1 Version Has Integrated Internal Ballast Resistor
LT3085	500mA, Parallelable Low Noise Low Dropout Linear Regulator	275mV Dropout Voltage (2 Supply Operation), Low Noise: 40µV <sub>RMS</sub> , V <sub>IN</sub> : 1.2V to 36V, V <sub>OUT</sub> : 0V to 35.7V, Current Reference, MSOP-8 and 2mm × 3mm DFN-6 Packages

ThinSOT is a trademark of Linear Technology Corporation

1118fd



Linear Technology Corporation  
1630 McCarthy Blvd., Milpitas, CA 95035-7417  
(408) 432-1900 • FAX: (408) 434-0507 • www.linear.com

LT 0209 REV D • PRINTED IN USA

**LINEAR**  
TECHNOLOGY  
© LINEAR TECHNOLOGY CORPORATION 1995

## Looking for pricing, stock, or lifecycle information?

Click below to explore more details on WIN SOURCE:

 [View LT1118CS8#TRPBF on WIN SOURCE](#)

 [Linear Technology](#) Information

## Optimize Your Supply Chain with WIN SOURCE Solutions

-  Global Sourcing Solution
-  Obsolete Management
-  Cost Control Management
-  Shortage Management
-  Alternative Solution
-  Excess Inventory Management