



**THE DATASHEET OF
MAX763AESA+T**





3.3V, Step-Down, Current-Mode PWM DC-DC Converters

General Description

The MAX748A/MAX763A are 3.3V-output CMOS, step-down switching regulators. The MAX748A accepts inputs from 3.3V to 16V and delivers up to 500mA. The MAX763A accepts inputs between 3.3V and 11V and delivers up to 500mA. Typical efficiencies are 85% to 90%. Quiescent supply current is 1.4mA (MAX763A), and only 0.2µA in shutdown.

Pulse-width-modulation (PWM) current-mode control provides precise output regulation and excellent transient responses. Output voltage accuracy is guaranteed to be $\pm 5\%$ over line, load, and temperature variations. Fixed-frequency switching allows easy filtering of output ripple and noise, as well as the use of small external components. A 22µH inductor works in most applications, so no magnetics design is necessary.

The MAX748A/MAX763A also feature cycle-by-cycle current limiting, overcurrent limiting, undervoltage lockout, and programmable soft-start protection. The MAX748A is available in 8-pin DIP and 16-pin wide SO packages; the MAX763A comes in 8-pin DIP and SO packages.

Applications

5V-to-3.3V Converters
Cellular Phones
Portable Instruments
Hand-Held Computers
Computer Peripherals

Typical Operating Circuit

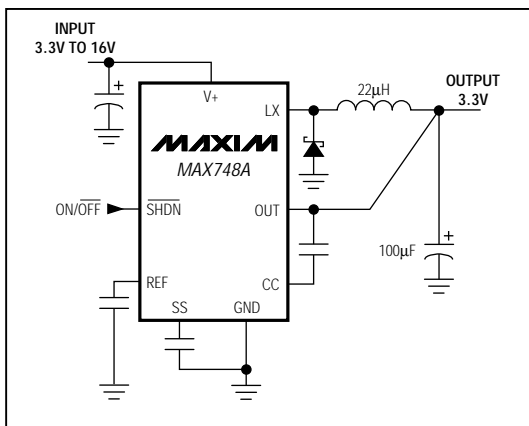

Features

- ◆ Up to 500mA Load Currents
- ◆ Guaranteed 159kHz to 219.5kHz Current-Mode PWM
- ◆ 85% to 90% Efficiencies
- ◆ 1.7mA Quiescent Current (MAX748A)
1.4mA Quiescent Current (MAX763A)
- ◆ 0.2µA Shutdown Supply Current
- ◆ 22µH Preselected Inductor Value;
No Component Design Required
- ◆ Overcurrent, Soft-Start, and Undervoltage Lockout Protection
- ◆ Cycle-by-Cycle Current Limiting
- ◆ 8-Pin DIP/SO Packages (MAX763A)

Ordering Information

PART	TEMP. RANGE	PIN-PACKAGE
MAX748ACPA	0°C to +70°C	8 Plastic DIP
MAX748ACWE	0°C to +70°C	16 Wide SO
MAX748AC/D	0°C to +70°C	Dice*
MAX748AEPA	-40°C to +85°C	8 Plastic DIP
MAX748AEWE	-40°C to +85°C	16 Wide SO
MAX748AMJA	-55°C to +125°C	8 CERDIP

Ordering Information continued on last page.

* Contact factory for dice specifications.

Pin Configurations

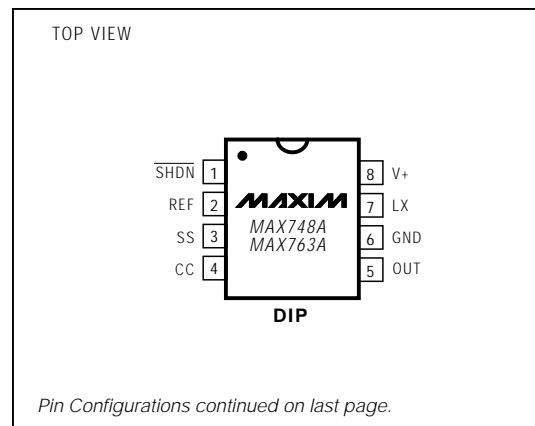

Pin Configurations continued on last page.



Maxim Integrated Products 1

Call toll free 1-800-998-8800 for free samples or literature.

MAX748A/MAX763A

3.3V, Step-Down, Current-Mode PWM DC-DC Converters

ABSOLUTE MAXIMUM RATINGS

Pin Voltages:

V+ (MAX748A)	+17V, -0.3V
V+ (MAX763A)	+12V, -0.3V
LX (MAX748A)	(V+ - 21V) to (V+ + 0.3V)
LX (MAX763A)	(V+ - 12V) to (V+ + 0.3V)
OUT	±25V
SS, CC, SHDN	-0.3V to (V+ + 0.3V)

Peak Switch Current (I_{LX})

Reference Current (I_{REF})

Continuous Power Dissipation (T_A = +70°C)

8-Pin Plastic DIP (derate 6.90mW/°C above +70°C) ...552mW

8-Pin SO (derate 5.88mW/°C above +70°C)471mW

16-Pin Wide SO (derate 9.52mW/°C above +70°C)762mW
8-Pin CERDIP (derate 8.00mW/°C above +70°C)640mW

Operating Temperature Ranges:

MAX7__AC__

MAX7__AE__

MAX7__AMJA__

Junction Temperatures:

MAX7__AC/E

MAX7__AM

Storage Temperature Range

Lead Temperature (soldering, 10sec)

Stresses beyond those listed under "Absolute Maximum Ratings" may cause permanent damage to the device. These are stress ratings only, and functional operation of the device at these or any other conditions beyond those indicated in the operational sections of the specifications is not implied. Exposure to absolute maximum rating conditions for extended periods may affect device reliability.

ELECTRICAL CHARACTERISTICS

(Circuit of Figure 3, V+ = 5V, I_{LOAD} = 0mA, T_A = T_{MIN} to T_{MAX}, unless otherwise noted.)

PARAMETER	CONDITIONS	MAX748A			MAX763A			UNITS
		MIN	TYP	MAX	MIN	TYP	MAX	
Input Voltage Range		3.3		16.0	3.3		11.0	V
Output Voltage	C/E temp. ranges, V+ = 4.0V to 16V, 0mA < I _{LOAD} < 300mA	3.135	3.3	3.465				V
	M temp. range, V+ = 4.0V to 16V, 0mA < I _{LOAD} < 250mA	3.135	3.3	3.465				
	C/E temp. ranges, V+ = 4.75V to 16V, 0mA < I _{LOAD} < 500mA	3.135	3.3	3.465				
	M temp. range, V+ = 4.75V to 16V, 0mA < I _{LOAD} < 400mA	3.135	3.3	3.465				
	C/E temp. ranges, V+ = 4.0V to 11V, 0mA < I _{LOAD} < 300mA				3.135	3.3	3.465	
	M temp. range, V+ = 4.0V to 11V, 0mA < I _{LOAD} < 250mA				3.135	3.3	3.465	
	C/E temp. ranges, V+ = 4.75V to 11V, 0mA < I _{LOAD} < 500mA				3.135	3.3	3.465	
	M temp. range, V+ = 4.75V to 11V, 0mA < I _{LOAD} < 400mA				3.135	3.3	3.465	
Line Regulation			0.13			0.13	%/V	
Load Regulation	I _{LOAD} = 0mA to 500mA		0.001			0.001	%/mA	

3.3V, Step-Down, Current-Mode PWM DC-DC Converters

MAX748A/MAX763A

ELECTRICAL CHARACTERISTICS (continued)

(Circuit of Figure 3, $V_+ = 5V$, $I_{LOAD} = 0mA$, $T_A = T_{MIN}$ to T_{MAX} , unless otherwise noted.)

PARAMETER	CONDITIONS		MAX748A			MAX763A			UNITS
			MIN	TYP	MAX	MIN	TYP	MAX	
Efficiency	$V_+ = 5V$	$I_{LOAD} = 300mA$	88			88			%
		$I_{LOAD} = 100mA$	90			90			
Supply Current	Includes switch current		1.7	3.0		1.4	2.5	mA	
Shutdown Current	$SHDN = 0V$ (Note 1)		0.2	100.0		0.2	100.0	μA	
Shutdown Input Threshold	V_{IH}		2.0			2.0			V
	V_{IL}					0.25			
Shutdown Input Leakage Current						1.0			μA
Short-Circuit Current			1.2			1.2			A
Undervoltage Lockout	V_+ falling		2.7	3.0		2.7	3.0	V	
LX On Resistance	$I_{LX} = 500mA$		1.0			1.0			Ω
LX Leakage Current	$V_+ = 12V$, $LX = 0$		10			10			nA
Reference Voltage	$T_A = +25^\circ C$		1.15	1.22	1.30	1.15	1.22	1.30	V
Reference Drift	$T_A = T_{MIN}$ to T_{MAX}		50			50			ppm/ $^\circ C$
Oscillator Frequency			159	180	212.5	159	200	212.5	kHz
Compensation Pin Impedance			7500			7500			Ω

Note 1: The standby current typically settles to $10\mu A$ (over temperature) within 2 seconds; however, to decrease test time, the part is guaranteed at a $100\mu A$ maximum value.

Typical Operating Characteristics

(Circuit of Figure 3, $T_A = +25^\circ C$, $V_{OUT} = 3.3V$, unless otherwise noted.)

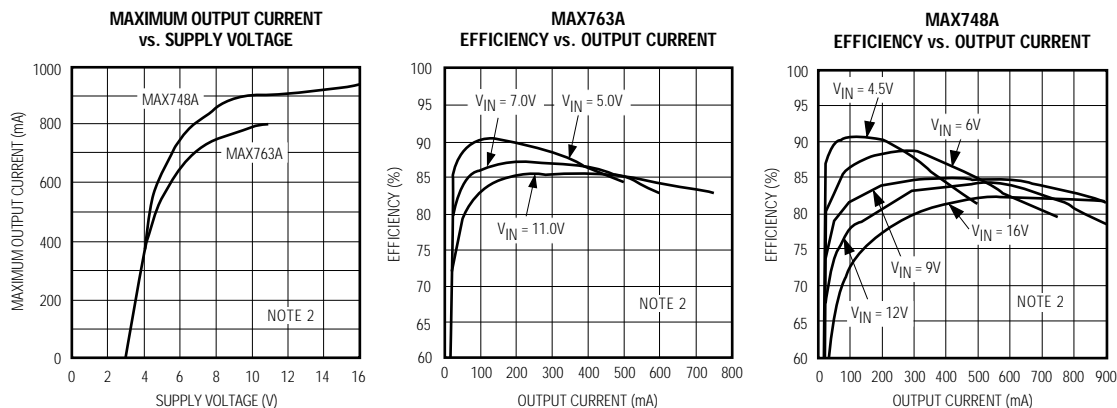

3.3V, Step-Down, Current-Mode PWM DC-DC Converters

Typical Operating Characteristics (continued)

(Circuit of Figure 3, $T_A = +25^\circ\text{C}$, $V_{\text{OUT}} = 3.3\text{V}$, unless otherwise noted.)

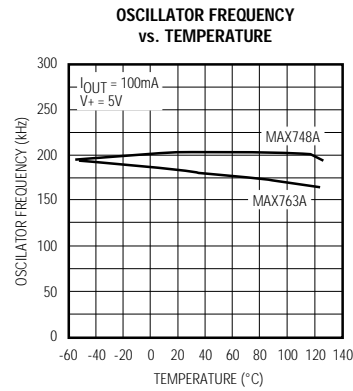
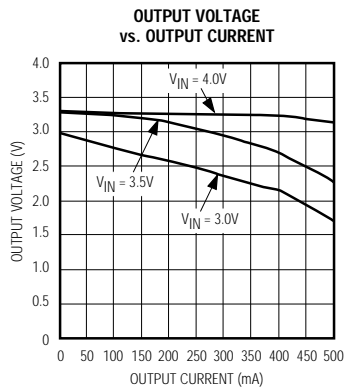
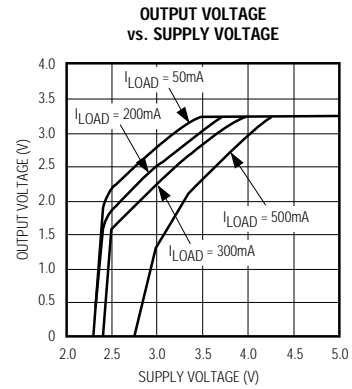
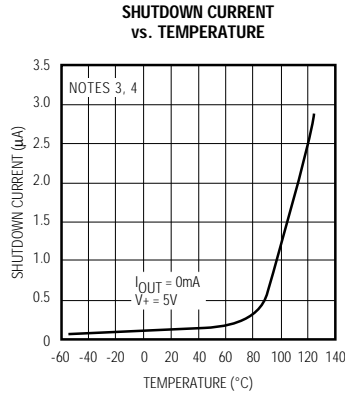
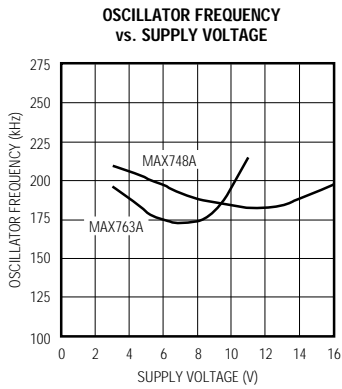
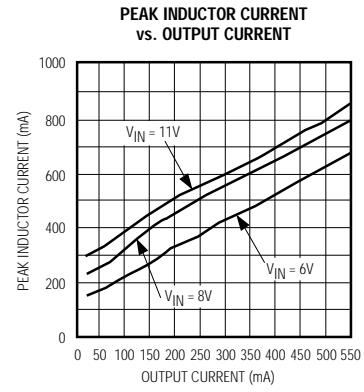
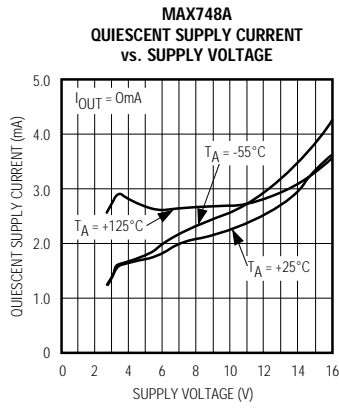
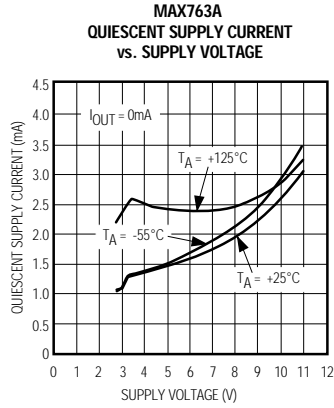

3.3V, Step-Down, Current-Mode PWM DC-DC Converters

MAX748A/MAX763A

Typical Operating Characteristics (continued)

(Circuit of Figure 3, $T_A = +25^\circ\text{C}$, $V_{OUT} = 3.3\text{V}$, unless otherwise noted.)

**SWITCHING WAVEFORMS,
CONTINUOUS CONDUCTION**

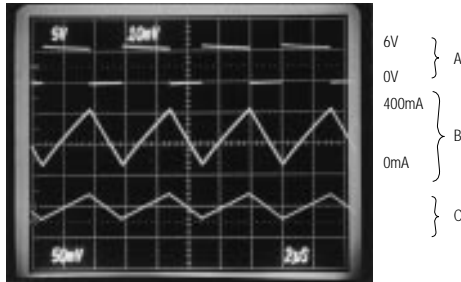

2µs/div

A: SWITCH VOLTAGE (LX PIN), 5V/div, 0V TO +6V
B: INDUCTOR CURRENT, 200mA/div
C: OUTPUT VOLTAGE RIPPLE, 50mV/div

$V_+ = 6\text{V}$, $I_{OUT} = 250\text{mA}$

**SWITCHING WAVEFORMS,
DISCONTINUOUS CONDUCTION**

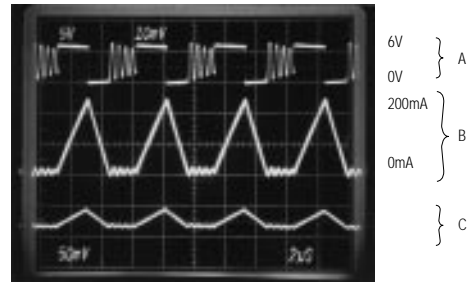

2µs/div

A: SWITCH VOLTAGE (LX PIN), 5V/div, 0V TO +6V
B: INDUCTOR CURRENT, 100mA/div
C: OUTPUT VOLTAGE RIPPLE, 50mV/div

$V_+ = 6\text{V}$, $I_{OUT} = 75\text{mA}$

LINE-TRANSIENT RESPONSE

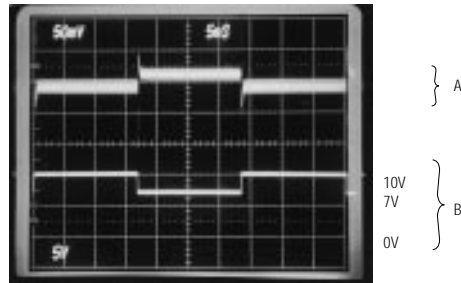

5ms/div

A: V_{OUT} , 50mV/div
B: V_+ , 5V/div, 7.0V TO 10.0V

$I_{OUT} = 350\text{mA}$

LOAD-TRANSIENT RESPONSE

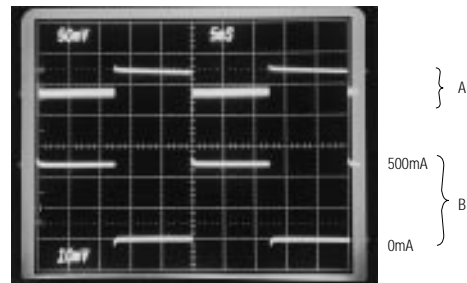

5ms/div

A: V_{OUT} , 50mV/div
B: I_{OUT} , 200mA/div, 0mA TO 500mA

$V_+ = 6\text{V}$

Note 2: Operation beyond the specifications listed in the *Electrical Characteristics* may exceed the power dissipation ratings of the device.

Note 3: Wide temperature range circuit of Figure 5 using Sprague surface-mount capacitors.

Note 4: Standby current includes all external component leakage currents. Capacitor leakage currents dominate at $T_A = +85^\circ\text{C}$.

3.3V, Step-Down, Current-Mode PWM DC-DC Converters

Pin Description

PIN #		NAME	FUNCTION
8-PIN DIP/SO	16-PIN WIDE SO (MAX748A)		
1	2	SHDN	Shutdown—active low. Connect to ground to power down chip; tie to V+ for normal operation. Output voltage falls to 0V when SHDN is low.
2	3	REF	Reference Voltage Output (+1.23V) supplies up to 100µA for external loads. Bypass to GND with a 0.047µF capacitor.
3	7	SS	Soft-Start. Capacitor between SS and GND provides soft-start and short-circuit protection.
4	8	CC	Compensation Capacitor Input externally compensates the outer (voltage) feedback loop. Connect to OUT with a 330pF capacitor.
5	9	OUT	Output-Voltage Sense Input provides regulation feedback sensing. Connect to +3.3V output.
6	10, 11	GND	Ground*
7	12, 13, 14	LX	Drain of internal P-channel power MOSFET*
8	1, 15, 16	V+	Supply Voltage Input. Bypass to GND with 1µF ceramic and large-value electrolytic capacitor in parallel. The 1µF capacitor must be as close to the GND and V+ pins as possible.*
	4, 5, 6	N.C.	No Connect—no internal connections to these pins.

*16-pin wide SO package: All pins sharing the same name must be connected together externally.

Detailed Description

The MAX748A/MAX763A switch-mode regulators use a current-mode pulse-width-modulation (PWM) control system in a step-down (buck) regulator topography. They convert an unregulated DC input voltage from 4V to 11V (MAX763A) or from 4V to 16V (MAX748A) to a regulated 3.3V output at 300mA. For loads less than 300mA, V+ may be less than 4.0V (see the Output Voltage vs. Supply Voltage graph in the *Typical Operating Characteristics*). The current-mode PWM architecture provides cycle-by-cycle current limiting, improved load-transient response, and simpler outerloop design.

The controller consists of two feedback loops: an inner (current) loop that monitors the switch current via the current-sense resistor and amplifier, and an outer (voltage) loop that monitors the output voltage through the error amplifier (Figure 1). The inner loop performs cycle-by-cycle current limiting, truncating the power transistor on-time when the switch current reaches a predetermined threshold. This threshold is determined by the outer loop. For example, a sagging output voltage produces an error signal that raises the threshold, allowing the circuit to store and transfer more energy during each cycle.

Programmable Soft-Start

Figure 2 shows a capacitor connected to the soft-start (SS) pin to ensure orderly power-up. A typical value is 0.047µF. SS controls both the SS timing and the maximum output current that can be delivered while maintaining regulation.

The charging capacitor slowly raises the clamp on the error-amplifier output voltage, limiting surge currents at power-up by slowly increasing the cycle-by-cycle current-limit threshold. Table 1 lists timing characteristics for selected capacitor values and circuit conditions.

The overcurrent comparator trips when the load exceeds approximately 1.2A. When either an undervoltage or overcurrent fault condition is detected, an SS cycle is actively initiated, which triggers an internal transistor to discharge the SS capacitor to ground. An SS cycle is also enabled at power-up and when coming out of shutdown mode.

Overcurrent Limiting

The overcurrent comparator triggers when the load current exceeds approximately 1.2A. On each clock cycle, the output FET turns on and attempts to deliver current until cycle-by-cycle or overcurrent limits are exceeded. Note that the SS capacitor must be greater than 0.01µF for overcurrent protection to function properly. A typical value is 0.047µF.

3.3V, Step-Down, Current-Mode PWM DC-DC Converters

MAX748A/MAX763A

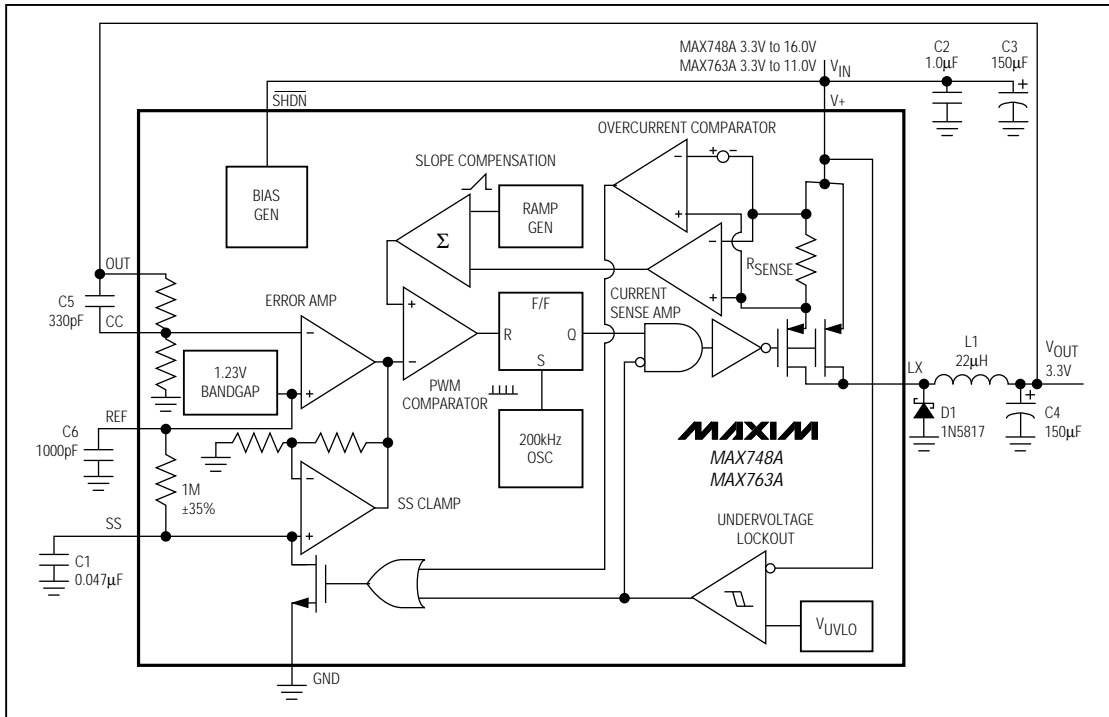

Figure 1. Detailed Block Diagram with External Components

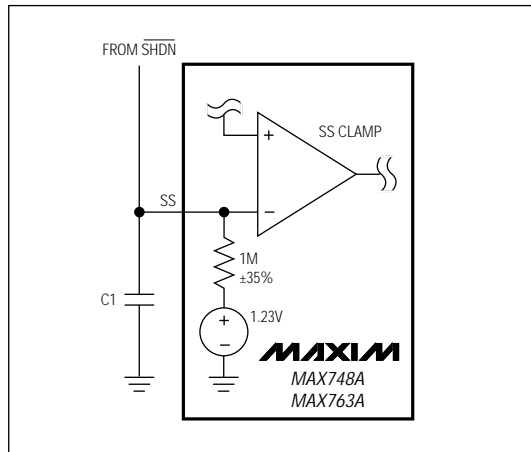

Figure 2. Soft-Start Circuitry Block Diagram

Table 1. Typical Soft-Start Times

(Circuit of Figure 3, C4 = 150µF)

V+ (V)	I _{OUT} (mA)	Soft-Start Time (ms) vs. C1 (µF)			
		C1 = 0.01	C1 = 0.047	C1 = 0.1	C1 = 0.47
8	0	1	4	7	12
12*	0	1	2	3	6
8	200	10	33	50	200
12*	200	7	17	20	80
8	300	13	44	65	325
12*	300	8	25	35	140

* MAX748A only

3.3V, Step-Down, Current-Mode PWM DC-DC Converters

Table 3. External Component Suppliers

Production Method	Inductors		Capacitors	
Surface Mount	Sumida CD105 series		Matsuo 267 series	
	Coiltronics CTX series		Sprague 595D/293D series	
	Coilcraft DT series			
High Performance/ Miniature Through-Hole	Sumida RCH895 series		Sanyo OS-CON series (very low ESR)	
Through-Hole	Renco RL1284 series		Nichicon PL series (low ESR)	
Phone and FAX Numbers:				
Coilcraft	USA: (708) 639-6400, FAX: (708) 639-1469	Renco	USA: (516) 586-5566, FAX: (516) 586-5562	
Coiltronics	USA: (305) 781-8900, FAX: (305) 782-4163	Sanyo	USA: (0720) 70-1005, FAX: (0720) 70-1174	
Matsuo	USA: (714) 969-2491, FAX: (714) 960-6492	Sprague Elec. Co.	USA: (603) 224-1961, FAX: (603) 224-1430	
	Japan: (06) 332-0871	Sumida	USA: (708) 956-0666, FAX: (708) 956-0702	
Nichicon	USA: (708) 843-7500, FAX: (708) 843-2798			
	Japan: (03) 3607-5111, FAX: (03) 3607-5428			

Undervoltage Lockout

The undervoltage lockout feature monitors the supply voltage at V₊ and allows operation to start when V₊ rises above 2.95V. When V₊ falls, operation continues until the supply voltage falls below 2.7V (typ). When an undervoltage condition is detected, control logic turns off the output power FET and discharges the SS capacitor to ground. This prevents partial turn-on of the power MOSFET and avoids excessive power dissipation. The control logic holds the output power FET off until the supply voltage rises above approximately 2.95V, at which time an SS cycle begins. When the input voltage exceeds the undervoltage lockout threshold, switching action will occur, but the output will not be regulated until the input voltage exceeds 3.3V (no load). The exact input voltage required for regulation depends on load conditions (see the Output Voltage vs. Supply Voltage graph in the *Typical Operating Characteristics*).

Shutdown Mode

The MAX748A/MAX763A are held in shutdown mode by keeping **SHDN** at ground. In shutdown mode, the output drops to 0V and the output power FET is held in an off state. The internal reference also turns off, which causes the SS capacitor to discharge. Typical supply current in shutdown mode is 0.2μA. The actual design limit for shutdown current is much less than the 100μA specified in the *Electrical Characteristics*. However, testing to tighter limits is prohibitive because the current takes several seconds to settle to a final value. For

normal operation, connect **SHDN** to V₊. Coming out of shutdown mode initiates an SS cycle.

Continuous-/Discontinuous-Conduction Modes

The input voltage, output voltage, load current, and inductor value determine whether the IC operates in continuous or discontinuous mode. As the inductor value or load current decreases, or the input voltage increases, the MAX748A/MAX763A tend to operate in discontinuous-conduction mode (DCM). In DCM, the inductor current slope is steep enough so it decays to zero before the end of the transistor off-time. In continuous-conduction mode (CCM), the inductor current never decays to zero, which is typically more efficient than DCM. CCM allows the MAX748A/MAX763A to deliver maximum load current, and is also slightly less noisy than DCM, because it doesn't exhibit the ringing that occurs when the inductor current reaches zero.

Internal Reference

The +1.23V bandgap reference supplies up to 100μA at REF. A 1000pF bypass capacitor from REF to GND is required.

Oscillator

The MAX748A/MAX763A's internal oscillator is guaranteed to operate in the 159kHz to 212.5 kHz range over temperature for V₊ = 5V. Temperature stability over the military temperature range is about 0.04%/°C.

3.3V, Step-Down, Current-Mode PWM DC-DC Converters

MAX748A/MAX763A

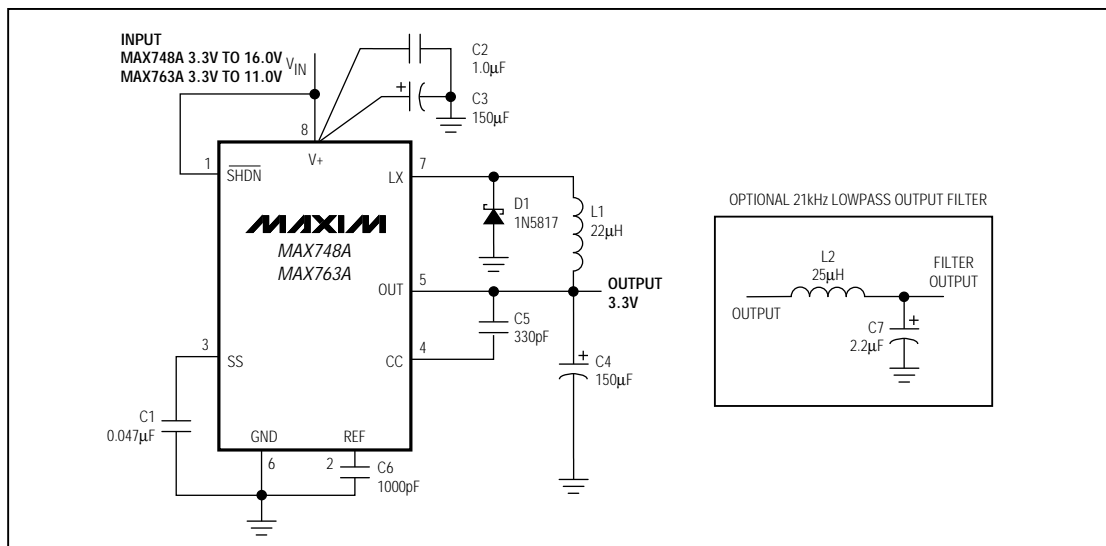

Figure 3. Standard 3.3V Step-Down Application Circuit Using Through-Hole Components (commercial temperature range)

Table 2. Component Table for Wide Temperature Applications

	C1(µF)	C2(µF)	C3(µF)	C4(µF)	C5(pF)	C6(pF)	L1(µH)
Through-Hole	0.047	1.0	150*	220*	330	1000	22
SO	0.047	1.0	68**	100***	330	1000	22

* Sanyo OS-CON Series (very low ESR)

** 16V or greater maximum voltage rating.

*** 6.3V or greater maximum voltage rating.

Applications Information

Fixed +3.3V Step-Down Converter Application

Figure 3 shows the standard 3.3V step-down circuit with components shown for commercial temperature range applications. Figures 4, 5, and Table 2 suggest external component values for both SO and through-hole wide temperature range applications. These circuits are useful in systems that require high current and high efficiency and are powered by an unregulated supply, such as a battery or wall-plug AC-DC adapter.

The MAX748A delivers a guaranteed 300mA for input voltages of 4V to 16V, and a guaranteed 500mA for

input voltages of 4.75V to 16V with 800mA typical output currents. The MAX763A delivers a guaranteed 300mA for input voltages of 4V to 11V, a guaranteed 500mA for input voltages of 4.75V to 11V, and has 700mA typical output currents. The MAX748A/MAX763A operate from an input down to 3V (the upper limit of undervoltage lockout), but with some reduction in output voltage and maximum output current.

Inductor Selection

The MAX748A/MAX763A require no inductor design because they are tested in-circuit, and are guaranteed to deliver the power specified in the *Electrical Characteristics* with high efficiency using a single 22µH inductor. The 22µH inductor's incremental saturation current rating should be greater than 1A for 500mA load operation. Table 3 lists inductor types and suppliers for various applications. The surface-mount inductors have nearly equivalent efficiencies to the larger through-hole inductors.

Output Filter Capacitor Selection

The primary criterion for selecting the output filter capacitor is low effective series resistance (ESR). The product of the inductor-current variation and the output capacitor's ESR determines the amplitude of the sawtooth ripple seen on the output voltage. Minimize the output filter capacitor's ESR to maintain AC stability.

3.3V, Step-Down, Current-Mode PWM DC-DC Converters

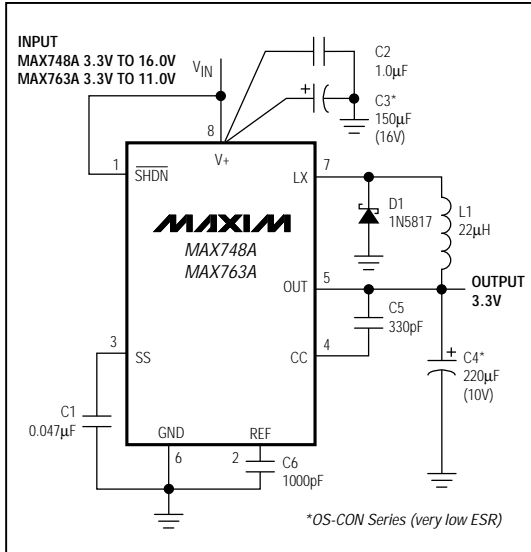

Figure 4. Standard 3.3V Step-Down Application Circuit Using Through-Hole Components (all temperature ranges)

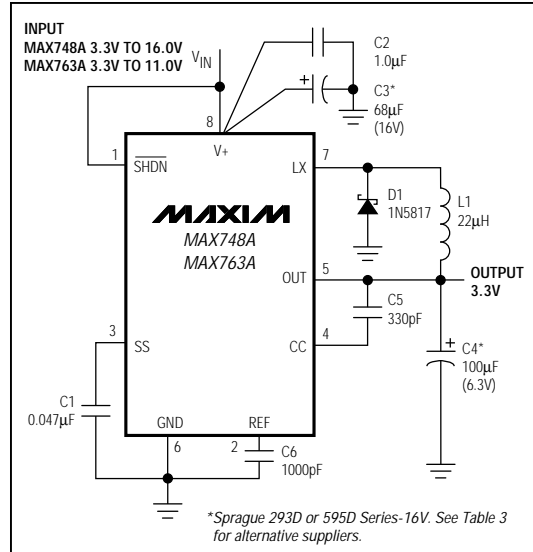

Figure 5. Standard 3.3V Step-Down Application Circuit Using Surface-Mount Components (Commercial and Extended Industrial Temperature Ranges)

The capacitor's ESR should be less than 0.25Ω to keep the output ripple less than $50\text{mV}_{\text{P-P}}$ over the entire current range (using a $22\mu\text{H}$ inductor). Capacitor ESR usually rises at low temperatures, but OS-CON capacitors provide very low ESR below 0°C . Table 3 lists capacitor suppliers.

Other Components

The catch diode should be a Schottky or high-speed silicon rectifier with a peak current rating of at least 1.0A for full-load (500mA) operation. The 1N5817 is a good choice. The 330pF outer-loop compensation capacitor provides the widest input voltage range and best transient characteristics.

Printed Circuit Layouts

A good layout is essential for stable, low-noise operation. The layouts and component placement diagrams

in Figures 6-9 have been tested successfully over a wide range of operating conditions. **The $1\mu\text{F}$ input bypass capacitor must be positioned as close to the $V+$ and GND pins as possible.** Also, place the output capacitor as close to the OUT and GND pins as possible. The traces connecting ground to the input and output filter capacitors and to the catch diode must be short to reduce inductance. Use an uninterrupted ground plane if possible.

Output-Ripple Filtering

A simple lowpass pi-filter (Figure 3) can be added to the output to reduce output ripple to about $5\text{mV}_{\text{P-P}}$. The cutoff frequency shown is 21kHz . Since the filter inductor is in series with the circuit output, minimize the filter inductor's resistance so the voltage drop across it is not excessive.

3.3V, Step-Down, Current-Mode PWM DC-DC Converters

MAX748A/MAX763A

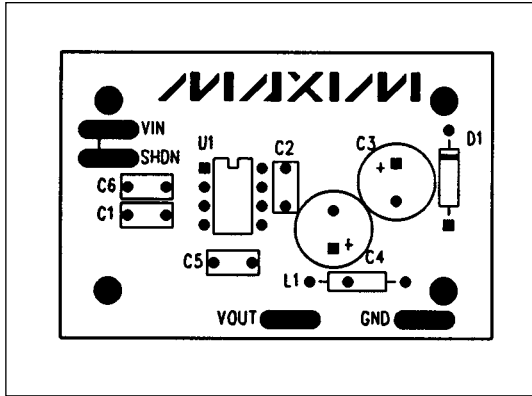

Figure 6. DIP PC Layout, Through-Hole Component Placement Diagram (1X Scale)

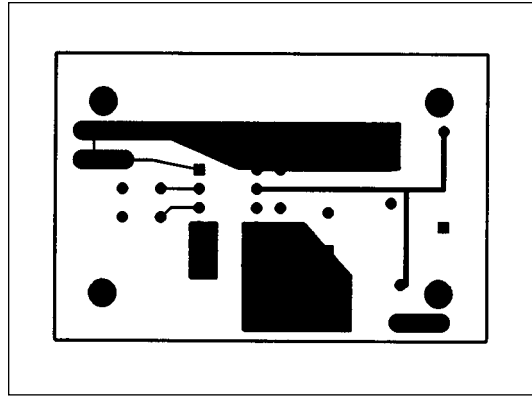

Figure 7. DIP PC Layout, Component Side (1X Scale)

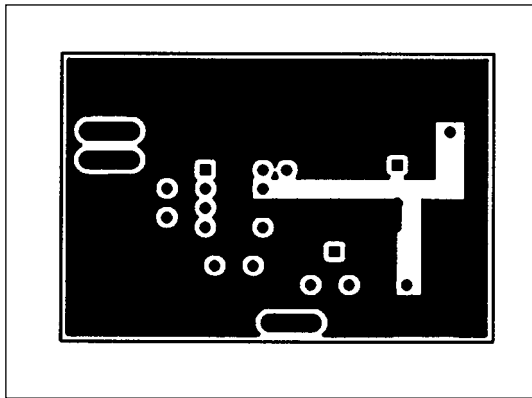

Figure 8. DIP PC Layout, Solder Side (1X Scale)

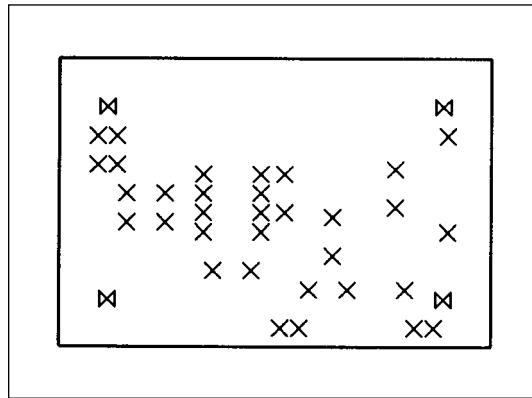
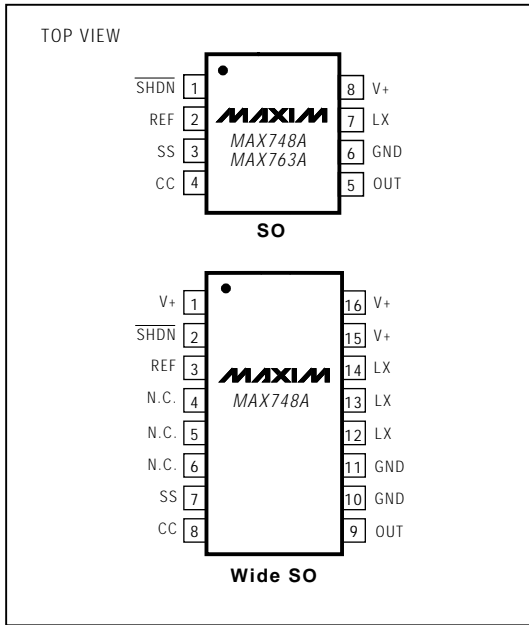

Figure 9. DIP PC Layout, Drill Guide (1X Scale)

3.3V, Step-Down, Current-Mode PWM DC-DC Converters

Pin Configurations (continued)



Ordering Information (continued)

PART	TEMP. RANGE	PIN-PACKAGE
MAX763ACPA	0°C to +70°C	8 Plastic DIP
MAX763ACSA	0°C to +70°C	8 SO
MAX763AC/D	0°C to +70°C	Dice*
MAX763AEPA	-40°C to +85°C	8 Plastic DIP
MAX763AESA	-40°C to +85°C	8 SO
MAX763AMJA	-55°C to +125°C	8 CERDIP

* Contact factory for dice specifications.

Chip Topographies

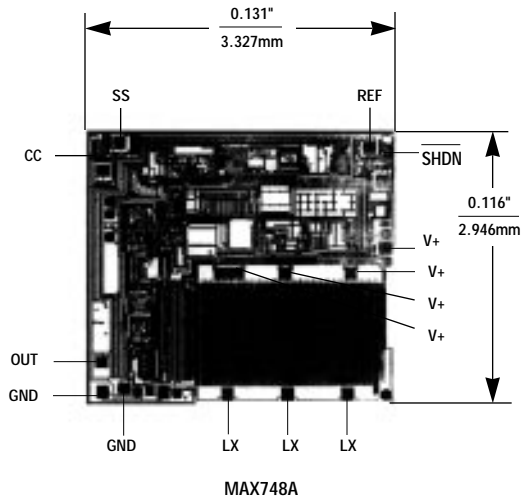

TRANSISTOR COUNT: 298
SUBSTRATE CONNECTION: V+

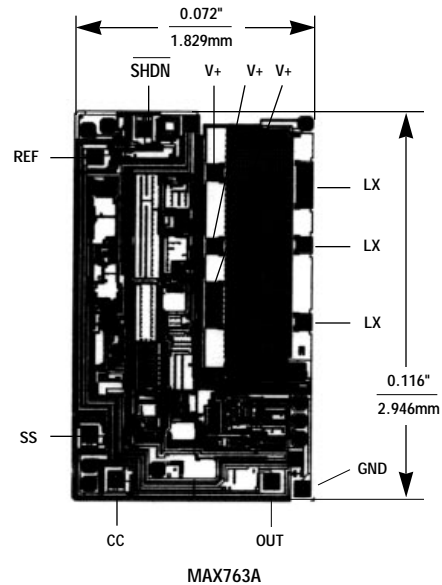

TRANSISTOR COUNT: 281
SUBSTRATE CONNECTION: V+

Looking for pricing, stock, or lifecycle information?

Click below to explore more details on WIN SOURCE:

- ⊖ [View MAX763AESA+T on WIN SOURCE](#)
- ⊖ [Maxim Integrated Information](#)

Optimize Your Supply Chain with WIN SOURCE Solutions

- ✓ Global Sourcing Solution
- ✓ Obsolete Management
- ✓ Cost Control Management
- ✓ Shortage Management
- ✓ Alternative Solution
- ✓ Excess Inventory Management