



**THE DATASHEET OF
ZL2006ALNFT1**



ZL2006

Adaptive Digital DC-DC Controller with Drivers and Current Sharing

FN76850
Rev. 1.00
December 15, 2010

Description

The ZL2006 is a digital DC-DC controller with integrated MOSFET drivers. Current sharing allows multiple devices to be connected in parallel to source loads with very high current demands. Adaptive performance optimization algorithms improve power conversion efficiency across the entire load range. Zilker Labs Digital-DC™ technology enables a blend of power conversion performance and power management features.

The ZL2006 is designed to be a flexible building block for DC power and can be easily adapted to designs ranging from a single-phase power supply operating from a 3.3 V input to a multi-phase supply operating from a 12 V input. The ZL2006 eliminates the need for complicated power supply managers as well as numerous external discrete components.

All operating features can be configured by simple pin-strap/resistor selection or through the SMBus™ serial interface. The ZL2006 uses the PMBus™ protocol for communication with a host controller and the Digital-DC bus for communication between other Zilker Labs devices.

Features

Power Conversion

- Efficient synchronous buck controller
- Adaptive light load efficiency optimization
- 3 V to 14 V input range
- 0.54 V to 5.5 V output range (with margin)
- ±1% output voltage accuracy
- Internal 3 A MOSFET drivers
- Fast load transient response
- Current sharing and phase interleaving
- *Snapshot*™ parameter capture
- RoHS compliant (6 x 6 mm) QFN package

Power Management

- Digital soft start / stop
- Precision delay and ramp-up
- Power good / enable
- Voltage tracking, sequencing, and margining
- Voltage / current / temperature monitoring
- I²C/SMBus interface, PMBus compatible
- Output voltage and current protection
- Internal non-volatile memory (NVM)

Applications

- Servers / storage equipment
- Telecom / datacom equipment
- Power supplies (memory, DSP, ASIC, FPGA)

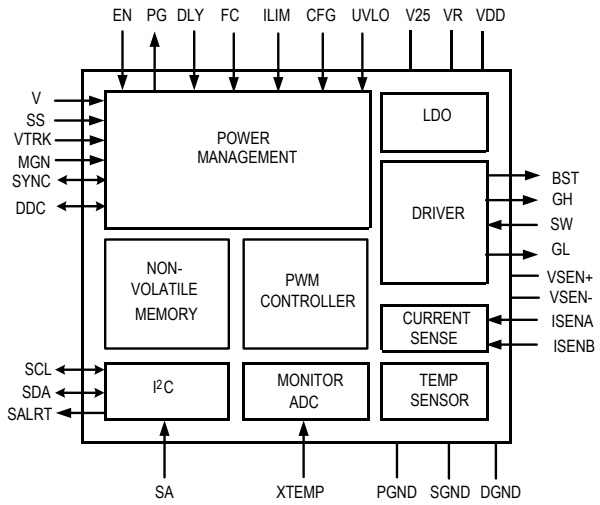

Figure 1. Block Diagram

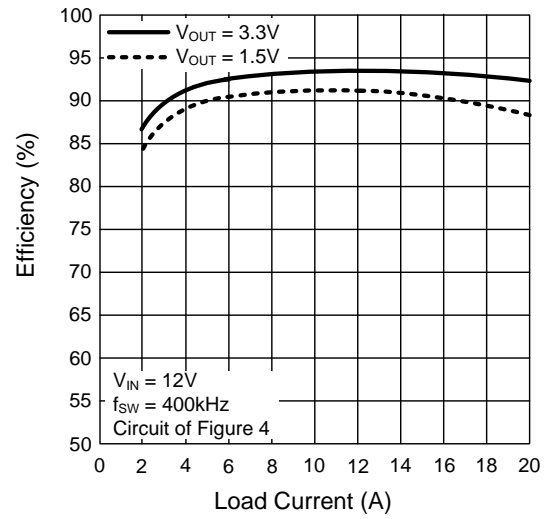

Figure 2. Efficiency vs. Load Current

Table of Contents

1. Electrical Characteristics	4
2. Pin Descriptions	8
3. Typical Application Circuit	10
4. ZL2006 Overview	11
4.1 Digital-DC Architecture	11
4.2 Power Conversion Overview	12
4.3 Power Management Overview	13
4.4 Multi-mode Pins	14
5. Power Conversion Functional Description	15
5.1 Internal Bias Regulators and Input Supply Connections	15
5.2 High-side Driver Boost Circuit	15
5.3 Output Voltage Selection	15
5.4 Start-up Procedure	18
5.5 Soft Start Delay and Ramp Times	18
5.6 Power Good	19
5.7 Switching Frequency and PLL	20
5.8 Power Train Component Selection	21
5.9 Current Limit Threshold Selection	25
5.10 Loop Compensation	28
5.11 Adaptive Compensation	29
5.12 Non-linear Response (NLR) Settings	29
5.13 Efficiency Optimized Driver Dead-time Control	29
5.14 Adaptive Diode Emulation	30
5.15 Adaptive Frequency Control	30
6. Power Management Functional Description	31
6.1 Input Undervoltage Lockout	31
6.2 Output Overvoltage Protection	31
6.3 Output Pre-Bias Protection	32
6.4 Output Overcurrent Protection	33
6.5 Thermal Overload Protection	33
6.6 Voltage Tracking	33
6.7 Voltage Margining	34
6.8 I ² C/SMBus Communications	35
6.9 I ² C/SMBus Device Address Selection	35
6.10 Digital-DC Bus	36
6.11 Phase Spreading	36
6.12 Output Sequencing	37
6.13 Fault Spreading	37
6.14 Temperature Monitoring Using the XTEMP Pin	38
6.15 Active Current Sharing	38
6.16 Phase Adding/Dropping	39
6.17 Monitoring via I ² C/SMBus	40
6.18 <i>Snapshot</i> TM Parameter Capture	40
6.19 Non-Volatile Memory and Device Security Features	41
7. Package Dimensions	42
8. Ordering Information	43
9. Related Tools and Documentation	43
10. Revision History	44

1. Electrical Characteristics

Table 1. Absolute Maximum Ratings

Operating beyond these limits may cause permanent damage to the device. Functional operation beyond the Recommended Operating Conditions is not implied. Voltage measured with respect to SGND.

Parameter	Pin	Value	Unit
DC supply voltage	VDD	- 0.3 to 17	V
MOSFET drive reference	VR	- 0.3 to 6.5	V
		120	mA
2.5 V logic reference	V25	- 0.3 to 3	V
		120	mA
Logic I/O voltage	CFG, DLY(0,1), DDC, EN, FC(0,1), ILIM(0,1), MGN, PG, SA(0,1), SALRT, SCL, SDA, SS, SYNC, UVLO, V(0,1)	- 0.3 to 6.5	V
Analog input voltages	ISENB, VSEN, VTRK, XTEMP	- 0.3 to 6.5	V
	ISENA	- 1.5 to 30	V
High side supply voltage	BST	- 0.3 to 30	V
Boost to switch voltage	BST - SW	- 0.3 to 8	V
High side drive voltage	GH	(V _{SW} -0.3) to (V _{BST} +0.3)	V
Low side drive voltage	GL	(PGND-0.3) to (VR+0.3)	V
Switch node continuous	SW	(PGND-0.3) to 30	V
Switch node transient (<100ns)	SW	(PGND-5) to 30	V
Ground differential	DGND – SGND, PGND - SGND	- 0.3 to 0.3	V
Junction temperature	–	- 55 to 150	°C
Storage temperature	–	- 55 to 150	°C
Lead temperature (Soldering, 10 s)	All	300	°C

Table 2. Recommended Operating Conditions and Thermal Information

Parameter	Symbol	Min	Typ	Max	Unit
Input supply voltage range, V _{DD} (See Figure 9)	V _{DD} tied to V _R	3.0	–	5.5	V
	V _R floating	4.5	–	14	V
Output voltage range ¹	V _{OUT}	0.54	–	5.5	V
Operating junction temperature range	T _J	- 40	–	125	°C
Junction to ambient thermal impedance ²	Θ _{JA}	–	35	–	°C/W
Junction to case thermal impedance ³	Θ _{JC}	–	5	–	°C/W

Notes:

- Includes margin limits
- Θ_{JA} is measured in free air with the device mounted on a multi-layer FR4 test board and the exposed metal pad soldered to a low impedance ground plane using multiple vias.
- For Θ_{JC}, the “case” temperature is measured at the center of the exposed metal pad

Table 3. Electrical Specifications

$V_{DD} = 12\text{ V}$, $T_A = -40^\circ\text{C}$ to 85°C unless otherwise noted. Typical values are at $T_A = 25^\circ\text{C}$.

Parameter	Conditions	Min (Note 10)	Typ	Max (Note 10)	Unit
Input and Supply Characteristics					
I_{DD} supply current at $f_{SW} = 200\text{ kHz}$	GH, GL no load;	–	16	30	mA
I_{DD} supply current at $f_{SW} = 1.4\text{ MHz}$	MISC_CONFIG[7] = 1	–	25	50	mA
I_{DDs} shutdown current	EN = 0 V No I ² C/SMBus activity	–	6.5	8	mA
VR reference output voltage	$V_{DD} > 6\text{ V}$, $I_{VR} < 50\text{ mA}$	4.5	5.2	5.5	V
V25 reference output voltage	$V_R > 3\text{ V}$, $I_{V25} < 50\text{ mA}$	2.25	2.5	2.75	V
Output Characteristics					
Output voltage adjustment range ¹	$V_{IN} > V_{OUT}$	0.6	–	5.0	V
Output voltage set-point resolution	Set using resistors	–	10	–	mV
	Set using I ² C/SMBus	–	±0.025	–	% FS ²
Output voltage accuracy ³	Includes line, load, temp	- 1	–	1	%
VSEN input bias current	VSEN = 5.5 V	–	110	200	μA
Current sense differential input voltage (ground referenced)	$V_{ISENA} - V_{ISENB}$	- 100	–	100	mV
Current sense differential input voltage (V_{OUT} referenced) (V_{OUT} must be less than 4.0 V)	$V_{ISENA} - V_{ISENB}$	- 50	–	50	mV
Current sense input bias current	Ground referenced	- 100	–	100	μA
Current sense input bias current (V_{OUT} referenced, $V_{OUT} < 4.0\text{ V}$)	ISENA	- 1	–	1	μA
	ISENB	- 100	–	100	μA
Soft start delay duration range ⁴	Set using DLY pin or resistor	2	–	200	ms
	Set using I ² C/SMBus	0.002	–	500	s
Soft start delay duration accuracy	Turn-on delay (precise mode) ^{4,5} Turn-on delay (normal mode) ⁶ Turn-off delay ⁶	–	±0.25	–	ms
		–	-	–	ms
		–	0.25/+4	–	ms
Soft start ramp duration range	Set using SS pin or resistor	0	–	200	ms
	Set using I ² C	0	–	200	ms
Soft start ramp duration accuracy		–	100	–	μs

- Notes:**
- Does not include margin limits.
 - Percentage of Full Scale (FS) with temperature compensation applied.
 - V_{OUT} measured at the termination of the VSEN+ and VSEN- sense points.
 - The device requires a delay period following an enable signal and prior to ramping its output. Precise timing mode limits this delay period to approx 2 ms, where in normal mode it may vary up to 4 ms.
 - Precise ramp timing mode is only valid when using EN pin to enable the device rather than PMBus enable.
 - The devices may require up to a 4 ms delay following the assertion of the enable signal (normal mode) or following the de-assertion of the enable signal.

Table 3. Electrical Characteristics (continued)

$V_{DD} = 12\text{ V}$, $T_A = -40^\circ\text{C}$ to 85°C unless otherwise noted. Typical values are at $T_A = 25^\circ\text{C}$.

Parameter	Conditions	Min (Note 10)	Typ	Max (Note 10)	Unit
Logic Input/Output Characteristics					
Logic input bias current	EN,PG,SCL,SDA,SALRT pins	- 10	–	10	μA
MGN input bias current		- 1	–	1	mA
Logic input low, V_{IL}		–	–	0.8	V
Logic input OPEN (N/C)	Multi-mode logic pins	–	1.4	–	V
Logic input high, V_{IH}		2.0	–	–	V
Logic output low, V_{OL}	$I_{OL} \leq 4\text{ mA}$	–	–	0.4	V
Logic output high, V_{OH}	$I_{OH} \geq -2\text{ mA}$	2.25	–	–	V
Oscillator and Switching Characteristics					
Switching frequency range		200	–	1400	kHz
Switching frequency set-point accuracy	Predefined settings (See Table 16)	- 5	–	5	%
Maximum PWM duty cycle	Factory default	95	–	–	%
Minimum SYNC pulse width		150	–	–	ns
Input clock frequency drift tolerance	External clock source	- 13	–	13	%
Gate Drivers					
High-side driver voltage ($V_{BST} - V_{SW}$)		–	4.5	–	V
High-side driver peak gate drive current (pull down)	$(V_{BST} - V_{SW}) = 4.5\text{ V}$	2	3	–	A
High-side driver pull-up resistance	$(V_{BST} - V_{SW}) = 4.5\text{ V}$, $(V_{BST} - V_{GH}) = 50\text{ mV}$	–	0.8	2	Ω
High-side driver pull-down resistance	$(V_{BST} - V_{SW}) = 4.5\text{ V}$, $(V_{GH} - V_{SW}) = 50\text{ mV}$	–	0.5	2	Ω
Low-side driver peak gate drive current (pull-up)	$V_R = 5\text{ V}$	–	2.5	–	A
Low-side driver peak gate drive current (pull-down)	$V_R = 5\text{ V}$	–	1.8	–	A
Low-side driver pull-up resistance	$V_R = 5\text{ V}$, $(V_R - V_{GL}) = 50\text{ mV}$	–	1.2	2	Ω
Low-side driver pull-down resistance	$V_R = 5\text{ V}$, $(V_{GL} - \text{PGND}) = 50\text{ mV}$	–	0.5	2	Ω
Switching timing	$(V_{BST} - V_{SW}) = 4.5\text{ V}$, $C_{LOAD} = 2.2\text{ nF}$	–	5	20	ns
GH rise and fall time	$V_R = 5\text{ V}$, $C_{LOAD} = 2.2\text{ nF}$	–	5	20	ns
GL rise and fall time		–	5	20	ns
Tracking					
VTRK input bias current	$V_{TRK} = 5.5\text{ V}$	–	110	200	μA
VTRK tracking ramp accuracy	100% Tracking, $V_{OUT} - V_{TRK}$	- 100	–	+ 100	mV
VTRK regulation accuracy	100% Tracking, $V_{OUT} - V_{TRK}$	- 1	–	1	%

Table 3. Electrical Characteristics (continued)

$V_{DD} = 12\text{ V}$, $T_A = -40^\circ\text{C}$ to 85°C unless otherwise noted. Typical values are at $T_A = 25^\circ\text{C}$.

Parameter	Conditions	Min (Note 10)	Typ	Max (Note 10)	Unit
Fault Protection Characteristics					
UVLO threshold range	Configurable via I ² C/SMBus	2.85	–	16	V
UVLO set-point accuracy		- 150	–	150	mV
UVLO hysteresis	Factory default	–	3	–	%
	Configurable via I ² C/SMBus	0	–	100	%
UVLO delay		–	–	2.5	μs
Power good V _{OUT} low threshold	Factory default	–	90	–	% V _{OUT}
Power good V _{OUT} high threshold	Factory default	–	115	–	% V _{OUT}
Power good V _{OUT} hysteresis	Factory default	–	5	–	%
Power good delay	Using pin-strap or resistor ⁷	0	–	200	ms
	Configurable via I ² C/SMBus	0	–	500	s
VSEN undervoltage threshold	Factory default	–	85	–	% V _{OUT}
	Configurable via I ² C/SMBus	0	–	110	% V _{OUT}
VSEN overvoltage threshold	Factory default	–	115	–	% V _{OUT}
	Configurable via I ² C/SMBus	0	–	115	% V _{OUT}
VSEN undervoltage hysteresis		–	5	–	% V _{OUT}
VSEN undervoltage/ overvoltage fault response time	Factory default	–	16	–	μs
	Configurable via I ² C/SMBus	5	–	60	μs
Current limit set-point accuracy (V _{OUT} referenced)		–	±10	–	% FS ⁸
Current limit set-point accuracy (Ground referenced)		–	±10	–	% FS ⁸
Current limit protection delay	Factory default	–	5	–	t _{sw} ⁹
	Configurable via I ² C/SMBus	1	–	32	t _{sw} ⁹
Temperature compensation of current limit protection threshold	Factory default		4400		ppm /
	Configurable via I ² C/SMBus	100		12700	°C
Thermal protection threshold (junction temperature)	Factory default	–	125	–	°C
	Configurable via I ² C/SMBus	- 40	–	125	°C
Thermal protection hysteresis		–	15	–	°C

Notes:

7. Factory default Power Good delay is set to the same value as the soft start ramp time.

8. Percentage of Full Scale (FS) with temperature compensation applied

9. $t_{sw} = 1/f_{sw}$, where f_{sw} is the switching frequency.

10. Compliance to datasheet limits is assured by one or more methods: production test, characterization and/or design.

2. Pin Descriptions

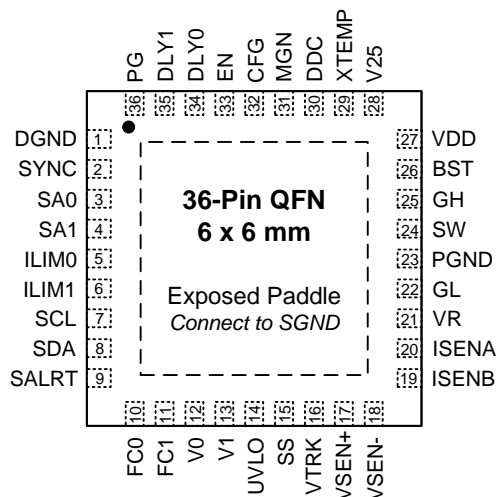

Figure 3. ZL2006 Pin Configurations (top view)

Table 4. Pin Descriptions

Pin	Label	Type ¹	Description
1	DGND	PWR	Digital ground. Common return for digital signals. Connect to low impedance ground plane.
2	SYNC	I/O,M ²	Clock synchronization input. Used to set switching frequency of internal clock or for synchronization to external frequency reference.
3	SA0	I, M	Serial address select pins. Used to assign unique SMBus address to each IC or to enable certain management features.
4	SA1		
5	ILIM0	I, M	Current limit select. Sets the overcurrent threshold voltage for ISENA, ISENB.
6	ILIM1		
7	SCL	I/O	Serial clock. Connect to external host and/or to other ZL2006s.
8	SDA	I/O	Serial data. Connect to external host and/or to other ZL2006s.
9	SALRT	O	Serial alert. Connect to external host if desired.
10	FC0	I	Loop compensation selection pins.
11	FC1		
12	V0	I	Output voltage selection pins. Used to set V_{OUT} set-point and V_{OUT} max.
13	V1		
14	UVLO	I, M	Undervoltage lockout selection. Sets the minimum value for V_{DD} voltage to enable V_{OUT} .
15	SS	I, M	Soft start pin. Set the output voltage ramp time during turn-on and turnoff.
16	VTRK	I	Tracking sense input. Used to track an external voltage source.
17	VSEN+	I	Output voltage feedback. Connect to output regulation point.

Notes:

1. I = Input, O = Output, PWR = Power or Ground. M = Multi-mode pins.
2. The SYNC pin can be used as a logic pin, a clock input or a clock output.

Table 4. Pin Descriptions (continued)

Pin	Label	Type ¹	Description
18	VSEN-	I	Output voltage feedback. Connect to load return or ground regulation point.
19	ISENB	I	Differential voltage input for current limit.
20	ISENA	I	Differential voltage input for current limit. High voltage tolerant.
21	VR	PWR	Internal 5V reference used to power internal drivers.
22	GL	O	Low side FET gate drive.
23	PGND	PWR	Power ground. Connect to low impedance ground plane.
24	SW	PWR	Drive train switch node.
25	GH	O	High-side FET gate drive.
26	BST	PWR	High-side drive boost voltage.
27	VDD ³	PWR	Supply voltage.
28	V25	PWR	Internal 2.5 V reference used to power internal circuitry.
29	XTEMP	I	External temperature sensor input. Connect to external 2N3904 diode connected transistor.
30	DDC	I/O	Digital-DC Bus. (Open Drain) Communication between Zilker Labs devices.
31	MGN	I	Signal that enables margining of output voltage.
32	CFG	I, M	Configuration pin. Used to control the switching phase offset, sequencing and other management features.
33	EN	I	Enable input. Active high signal enables PWM switching.
34	DLY0	I, M	Softstart delay select. Sets the delay from when EN is asserted until the output voltage starts to ramp.
35	DLY1		
36	PG	O	Power good output.
ePad	SGND	PWR	Exposed thermal pad. Common return for analog signals; internal connection to SGND. Connect to low impedance ground plane.

Notes:

1. I = Input, O = Output, PWR = Power or Ground. M = Multi-mode pins. Please refer to Section 4.4“Multi-mode Pins,” on page 14.
2. The SYNC pin can be used as a logic pin, a clock input or a clock output.
3. V_{DD} is measured internally and the value is used to modify the PWM loop gain.

3. Typical Application Circuit

The following application circuit represents a typical implementation of the ZL2006. For PMBus operation, it is recommended to tie the enable pin (EN) to SGND.

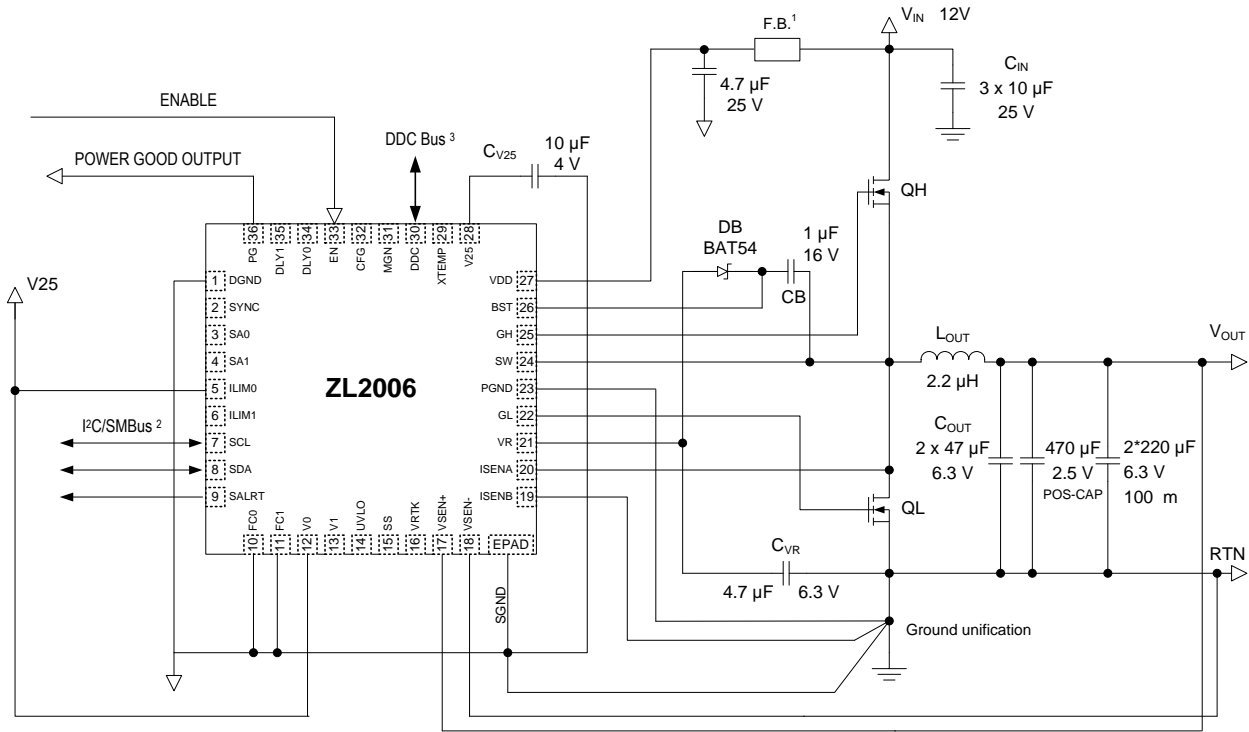

Notes:

1. Ferrite bead is optional for input noise suppression
2. The I²C/SMBus requires pull-up resistors. Please refer to the I²C/SMBus specifications for more details.
3. The DDC bus requires a pull-up resistor. The resistance will vary based on the capacitive loading of the bus (and on the number of devices connected). The 10 kΩ default value, assuming a maximum of 100 pF per device, provides the necessary 1 µs pull-up rise time. Please refer to the DDC Bus section for more details.

**Figure 4. 12 V to 1.8 V / 20 A Application Circuit
(4.5 V UVLO, 10 ms SS delay, 5 ms SS ramp)**

4. ZL2006 Overview

4.1 Digital-DC Architecture

The ZL2006 is an innovative mixed-signal power conversion and power management IC based on Zilker Labs patented Digital-DC technology that provides an integrated, high performance step-down converter for a wide variety of power supply applications.

Today's embedded power systems are typically designed for optimal efficiency at maximum load, reducing the peak thermal stress by limiting the total thermal dissipation inside the system. Unfortunately, many of these systems are often operated at load levels far below the peak where the power system has been optimized, resulting in reduced efficiency. While this may not cause thermal stress to occur, it does contribute to higher electricity usage and results in higher overall system operating costs.

Zilker Labs' efficiency-adaptive ZL2006 DC-DC controller helps mitigate this scenario by enabling the power converter to automatically change their operating state to increase efficiency and overall performance with little or no user interaction needed.

Its unique PWM loop utilizes an ideal mix of analog and digital blocks to enable precise control of the entire power conversion process with no software required, resulting in a very flexible device that is also very easy to use. An extensive set of power management functions are fully integrated and can be configured using simple pin connections. The user configuration can be saved in an internal non-volatile memory (NVM). Additionally, all functions can be configured and monitored via the SMBus hardware interface using

standard PMBus commands, allowing ultimate flexibility.

Once enabled, the ZL2006 is immediately ready to regulate power and perform power management tasks with no programming required. Advanced configuration options and real-time configuration changes are available via the I²C/SMBus interface if desired and continuous monitoring of multiple operating parameters is possible with minimal interaction from a host controller. Integrated sub-regulation circuitry enables single supply operation from any supply between 3 V and 14 V with no secondary bias supplies needed.

The ZL2006 can be configured by simply connecting its pins according to the tables provided in the following sections. Additionally, a comprehensive set of online tools and application notes are available to help simplify the design process. An evaluation board is also available to help the user become familiar with the device. This board can be evaluated as a standalone platform using pin configuration settings. A Windows™-based GUI is also provided to enable full configuration and monitoring capability via the I²C/SMBus interface using an available computer and the included USB cable.

Application notes and reference designs are available to assist the user in designing to specific application demands. Please register for My ZL on www.zilkerlabs.com to access the most up-to-date documentation or call your local Zilker Labs sales office to order an evaluation kit.

4.2 Power Conversion Overview

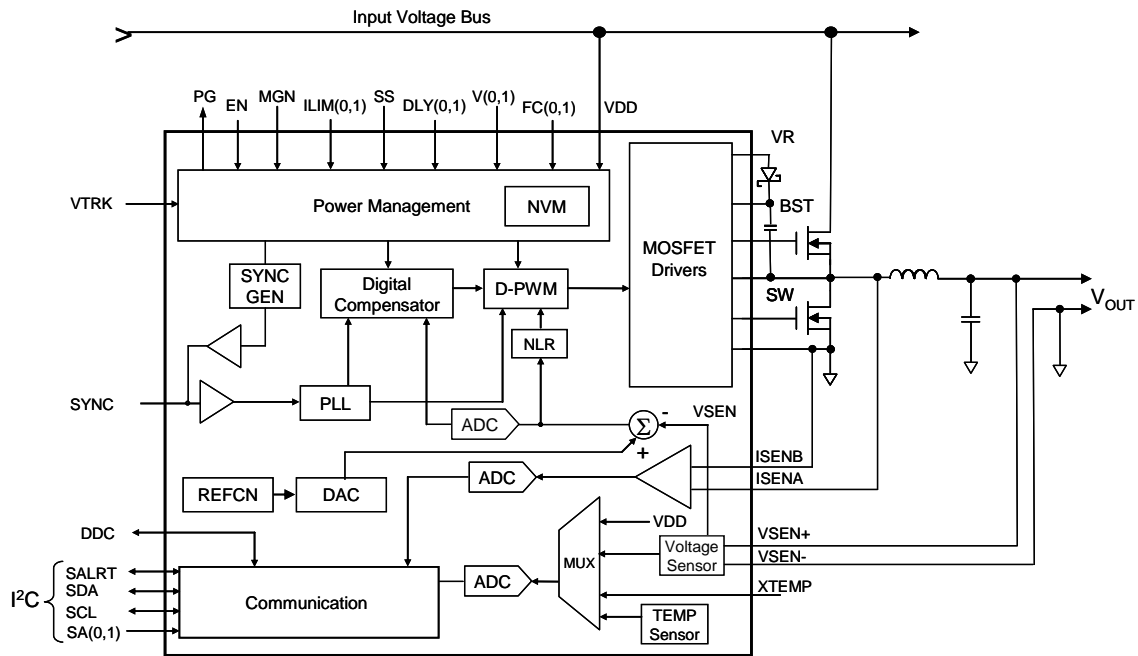

Figure 5. ZL2006 Block Diagram

The ZL2006 operates as a voltage-mode, synchronous buck converter with a selectable constant frequency pulse width modulator (PWM) control scheme that uses external MOSFETs, capacitors, and an inductor to perform power conversion.

$$D \approx \frac{V_{OUT}}{V_{IN}}$$

During time D , QH is on and $V_{IN} - V_{OUT}$ is applied across the inductor. The current ramps up as shown in Figure 7.

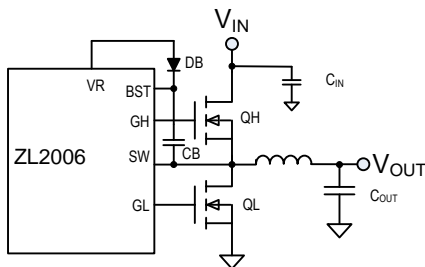

Figure 6. Synchronous Buck Converter

Figure 6 illustrates the basic synchronous buck converter topology showing the primary power train components. This converter is also called a step-down converter, as the output voltage must always be lower than the input voltage. In its most simple configuration, the ZL2006 requires two external N-channel power MOSFETs, one for the top control MOSFET (QH) and one for the bottom synchronous MOSFET (QL). The amount of time that QH is on as a fraction of the total switching period is known as the duty cycle D , which is described by the following equation:

When QH turns off (time $1-D$), the current flowing in the inductor must continue to flow from the ground up through QL, during which the current ramps down. Since the output capacitor C_{OUT} exhibits a low impedance at the switching frequency, the AC component of the inductor current is filtered from the output voltage so the load sees nearly a DC voltage.

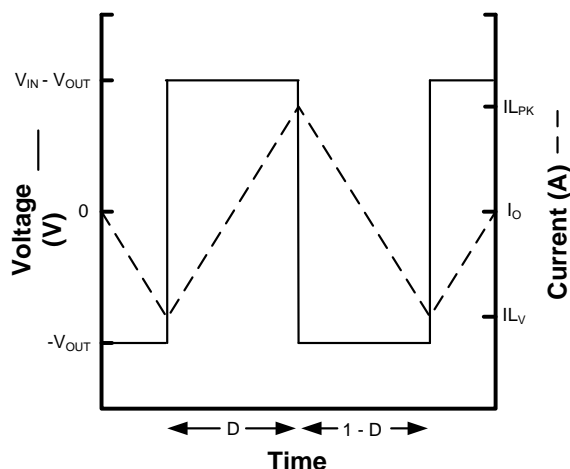

Figure 7. Inductor Waveform

Typically, buck converters specify a maximum duty cycle that effectively limits the maximum output voltage that can be realized for a given input voltage. This duty cycle limit ensures that the lowside MOSFET is allowed to turn on for a minimum amount of time during each switching cycle, which enables the bootstrap capacitor (CB in Figure 6) to be charged up and provide adequate gate drive voltage for the high-side MOSFET. See Section 5.2, “High-side Driver Boost Circuit,” for more details.

In general, the size of components L_1 and C_{OUT} as well as the overall efficiency of the circuit are inversely proportional to the switching frequency, f_{sw} . Therefore, the highest efficiency circuit may be realized by switching the MOSFETs at the lowest possible frequency; however, this will result in the largest component size. Conversely, the smallest possible footprint may be realized by switching at the fastest possible frequency but this gives a somewhat lower efficiency. Each user should determine the optimal combination of size and efficiency when determining the switching frequency for each application.

The block diagram for the ZL2006 is illustrated in Figure 5. In this circuit, the target output voltage is regulated by connecting the differential VSEN pins directly to the output regulation point. The VSEN signal is then compared to a reference voltage that has been set to the desired output voltage level by the user. The error signal derived from this comparison is converted to a digital value with a low-resolution, analog to digital (A/D) converter. The digital signal is applied to an adjustable digital compensation filter, and the compensated signal is used to derive the appropriate PWM duty cycle for driving the external MOSFETs in a way that produces the desired output.

The ZL2006 has several features to improve the power conversion efficiency. A non-linear response (NLR) loop improves the response time and reduces the output deviation as a result of a load transient. The ZL2006 monitors the power converter’s operating conditions and continuously adjusts the turn-on and turn-off timing of the high-side and low-side MOSFETs to optimize the overall efficiency of the power supply. Adaptive performance optimization algorithms such as dead-time control, diode emulation, and frequency control are available to provide greater efficiency improvement.

4.3 Power Management Overview

The ZL2006 incorporates a wide range of configurable power management features that are simple to implement with no external components. Additionally, the ZL2006 includes circuit protection features that continuously safeguard the device and load from damage due to unexpected system faults. The ZL2006 can continuously monitor input voltage, output voltage/current, internal temperature, and the temperature of an external thermal diode. A Power Good output signal is also included to enable power-on reset functionality for an external processor.

All power management functions can be configured using either pin configuration techniques (see Figure 8) or via the I²C/SMBus interface. Monitoring parameters can also be pre-configured to provide alerts for specific conditions. See Application Note AN33 for more details on SMBus monitoring.

4.4 Multi-mode Pins

In order to simplify circuit design, the ZL2006 incorporates patented multi-mode pins that allow the user to easily configure many aspects of the device with no programming. Most power management features can be configured using these pins. The multi-mode pins can respond to four different connections as shown in Table 5. These pins are sampled when power is applied or by issuing a PMBus Restore command (See Application Note AN33).

Pin-strap Settings: This is the simplest implementation method, as no external components are required. Using this method, each pin can take on one of three possible states: LOW, OPEN, or HIGH. These pins can be connected to the V25 pin for logic HIGH settings as this pin provides a regulated voltage higher than 2 V. Using a single pin, one of three settings can be selected. Using two pins, one of nine settings can be selected.

Table 5. Multi-mode Pin Configuration

Pin Tied To	Value
LOW (Logic LOW)	< 0.8 VDC
OPEN (N/C)	No connection
HIGH (Logic HIGH)	> 2.0 VDC
Resistor to SGND	Set by resistor value

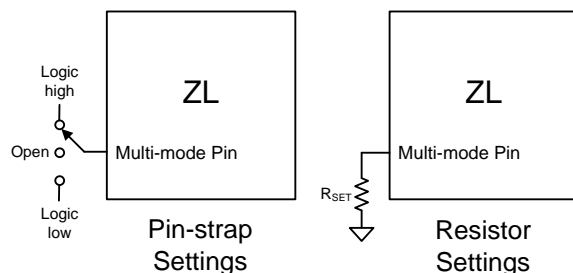

Figure 8. Pin-strap and Resistor Setting Examples

Resistor Settings: This method allows a greater range of adjustability when connecting a finite value resistor (in a specified range) between the multi-mode pin and SGND. Standard 1% resistor values are used, and only every fourth E96 resistor value is used so the device can reliably recognize the value of resistance connected to the pin while eliminating the error associated with the resistor accuracy. Up to 31 unique selections are available using a single resistor.

I²C/SMBus Method: Almost any ZL2006 function can be configured via the I²C/SMBus interface using standard PMBus commands. Additionally, any value that has been configured using the pin-strap or resistor setting methods can also be re-configured and/or verified via the I²C/SMBus. See Application Note AN33 for more details.

The SMBus device address and VOUT_MAX are the only parameters that must be set by external pins. All other device parameters can be set via the I²C/SMBus. The device address is set using the SA0 and SA1 pins. VOUT_MAX is determined as 10% greater than the voltage set by the V0 and V1 pins.

5. Power Conversion Functional Description

5.1 Internal Bias Regulators and Input Supply Connections

The ZL2006 employs two internal low dropout (LDO) regulators to supply bias voltages for internal circuitry, allowing it to operate from a single input supply. The internal bias regulators are as follows:

VR: The VR LDO provides a regulated 5 V bias supply for the MOSFET driver circuits. It is powered from the VDD pin. A 4.7 μF filter capacitor is required at the VR pin.

V25: The V25 LDO provides a regulated 2.5 V bias supply for the main controller circuitry. It is powered from an internal 5V node. A 10 μF filter capacitor is required at the V25 pin.

When the input supply (VDD) is higher than 5.5 V, the VR pin should not be connected to any other pins. It should only have a filter capacitor attached as shown in Figure 9. Due to the dropout voltage associated with the VR bias regulator, the VDD pin must be connected to the VR pin for designs operating from a supply below 5.5 V. Figure 9 illustrates the required connections for both cases.

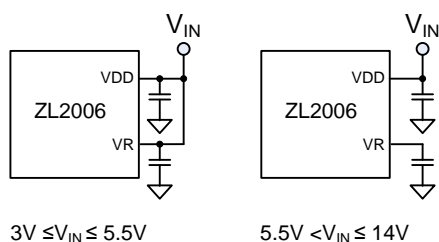

Figure 9. Input Supply Connections

Note: the internal bias regulators are not designed to be outputs for powering other circuitry. Do not attach external loads to any of these pins. The multi-mode pins may be connected to the V25 pin for logic HIGH settings.

5.2 High-side Driver Boost Circuit

The gate drive voltage for the high-side MOSFET driver is generated by a floating bootstrap capacitor, CB (see Figure 6). When the lower MOSFET (QL) is turned on, the SW node is pulled to ground and the capacitor is charged from the internal VR bias regulator through diode DB. When QL turns off and the upper MOSFET (QH) turns on, the SW node is pulled up to V_{DD} and the voltage on the bootstrap capacitor is boosted approximately 5 V above V_{DD} to provide the necessary voltage to power the high-side driver. A Schottky diode should be used for DB to help maximize the high-side drive supply voltage.

5.3 Output Voltage Selection

5.3.1 Standard Mode

The output voltage may be set to any voltage between 0.6 V and 5.0 V provided that the input voltage is higher than the desired output voltage by an amount sufficient to prevent the device from exceeding its maximum duty cycle specification. Using the pin-strap method, V_{OUT} can be set to any of nine standard voltages as shown in Table 6.

Table 6. Pin-strap Output Voltage Settings

		V0		
		LOW	OPEN	HIGH
V1	LOW	0.6 V	0.8 V	1.0 V
	OPEN	1.2 V	1.5 V	1.8 V
	HIGH	2.5 V	3.3 V	5.0 V

The resistor setting method can be used to set the output voltage to levels not available in Table 6. Resistors R0 and R1 are selected to produce a specific voltage between 0.6 V and 5.0 V in 10 mV steps. Resistor R1 provides a coarse setting and resistor R0 provides a fine adjustment, thus eliminating the additional errors associated with using two 1% resistors (this typically adds approx 1.4% error).

To set V_{OUT} using resistors, follow the steps below to calculate an index value and then use Table 7 to select the resistor that corresponds to the calculated index value as follows:

1. Calculate Index1:
Index1 = $4 \times V_{OUT}$ (V_{OUT} in 10 mV steps)
2. Round the result down to the nearest whole number.
3. Select the value of R1 from Table 7 using the Index1 rounded value from step 2.
4. Calculate Index0:
Index0 = $100 \times V_{OUT} - (25 \times \text{Index1})$
5. Select the value of R0 from Table 7 using the Index0 value from step 4.

Table 7. Resistors for Setting Output Voltage

Index	R0 or R1	Index	R0 or R1
0	10 k Ω	13	34.8 k Ω
1	11 k Ω	14	38.3 k Ω
2	12.1 k Ω	15	42.2 k Ω
3	13.3 k Ω	16	46.4 k Ω
4	14.7 k Ω	17	51.1 k Ω
5	16.2 k Ω	18	56.2 k Ω
6	17.8 k Ω	19	61.9 k Ω
7	19.6 k Ω	20	68.1 k Ω
8	21.5 k Ω	21	75 k Ω
9	23.7 k Ω	22	82.5 k Ω
10	26.1 k Ω	23	90.9 k Ω
11	28.7 k Ω	24	100 k Ω
12	31.6 k Ω		

Example from Figure 10: For $V_{OUT} = 1.33$ V,

$$\text{Index1} = 4 \times 1.33 \text{ V} = 5.32;$$

From Table 7, R1 = 16.2 k Ω

$$\text{Index0} = (100 \times 1.33 \text{ V}) - (25 \times 5) = 8;$$

From Table 7, R0 = 21.5 k Ω

The output voltage can be determined from the R0 (Index0) and R1 (Index1) values using the following equation:

$$V_{OUT} = \frac{\text{Index0} + (25 \times \text{Index1})}{100}$$

5.3.2 SMBus Mode

The output voltage may be set to any value between 0.6 V and 5.0 V using a PMBus command over the I²C/SMBus interface. See Application Note AN33 for details.

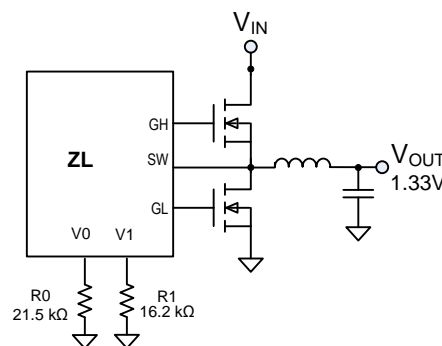

Figure 10. Output Voltage Resistor Setting Example

5.3.3 POLA Voltage Trim Mode

The output voltage mapping can be changed to match the voltage setting equations for POLA and DOSA standard modules.

The standard method for adjusting the output voltage for a POLA module is defined by the following equation:

$$R_{SET} = 10\text{k}\Omega \times \frac{0.69\text{V}}{V_{OUT} - 0.69\text{V}} - 1.43\text{k}\Omega$$

The resistor, R_{SET} , is external to the POLA module. See Figure 11.

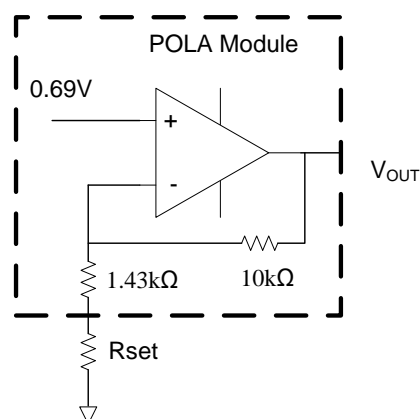

Figure 11. Output Voltage Setting on POLA Module

To stay compatible with this existing method for adjusting the output voltage, the module manufacturer should add a 10kΩ resistor on the module as shown in Figure 12. Now, the same R_{SET} used for an analog POLA module will provide the same output voltage when using a digital POLA module based on the ZL2006.

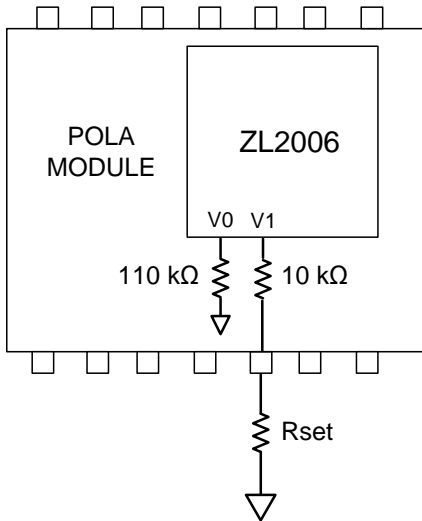

Figure 12. R_{SET} on a POLA Module

The POLA mode is activated through pin-strap by connecting a 110 kΩ resistor on V0 to SGND. The V1 pin is then used to adjust the output voltage as shown in Table 8.

Table 8. POLA Mode V_{OUT} Settings

(R₀ = 110 kΩ, R₁ = R_{SET} + 10 kΩ)

V _{OUT}	R _{SET} In series with 10kΩ resistor	V _{OUT}	R _{SET} In series with 10kΩ resistor
0.700 V	162 kΩ	0.991 V	21.5 kΩ
0.752 V	110 kΩ	1.000 V	19.6 kΩ
0.758 V	100 kΩ	1.100 V	16.2 kΩ
0.765 V	90.9 kΩ	1.158 V	13.3 kΩ
0.772 V	82.5 kΩ	1.200 V	12.1 kΩ
0.790 V	75.0 kΩ	1.250 V	9.09 kΩ
0.800 V	56.2 kΩ	1.500 V	7.50 kΩ
0.821 V	51.1 kΩ	1.669 V	5.62 kΩ
0.834 V	46.4 kΩ	1.800 V	4.64 kΩ
0.848 V	42.2 kΩ	2.295 V	2.87 kΩ
0.880 V	34.8 kΩ	2.506 V	2.37 kΩ
0.899 V	31.6 kΩ	3.300 V	1.21 kΩ
0.919 V	28.7 kΩ	5.000 V	0.162 kΩ
0.965 V	23.7 kΩ		

5.3.4 DOSA Voltage Trim Mode

On a DOSA module, the V_{OUT} setting follows this equation:

$$R_{SET} = \frac{6900}{V_{OUT} - 0.69V}$$

To maintain DOSA compatibility, the same scheme is used as with a POLA module except the 10 kΩ resistor is replaced with a 8.66 kΩ resistor as shown in Figure 13.

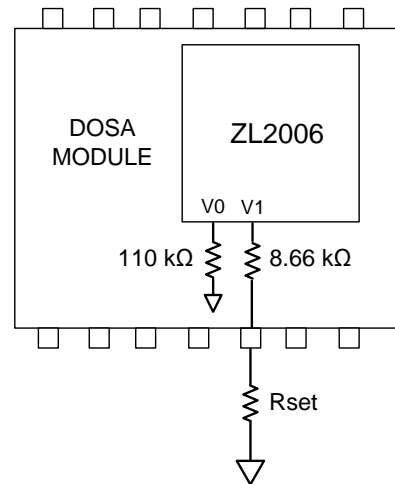

Figure 13. R_{SET} on a DOSA Module

The DOSA mode V_{OUT} settings are listed in Table 9.

Table 9. DOSA Mode V_{OUT} Settings

(R₀ = 110 kΩ, R₁ = R_{SET} + 8.66 kΩ)

V _{OUT}	R _{SET} In series with 8.66kΩ resistor	V _{OUT}	R _{SET} In series with 8.66kΩ resistor
0.700 V	162 kΩ	0.991 V	22.6 kΩ
0.752 V	113 kΩ	1.000 V	21.0 kΩ
0.758 V	100 kΩ	1.100 V	17.8 kΩ
0.765 V	90.9 kΩ	1.158 V	14.7 kΩ
0.772 V	82.5 kΩ	1.200 V	13.3 kΩ
0.790 V	75.0 kΩ	1.250 V	10.5 kΩ
0.800 V	57.6 kΩ	1.500 V	8.87 kΩ
0.821 V	52.3 kΩ	1.669 V	6.98 kΩ
0.834 V	47.5 kΩ	1.800 V	6.04 kΩ
0.848 V	43.2 kΩ	2.295 V	4.32 kΩ
0.880 V	36.5 kΩ	2.506 V	3.74 kΩ
0.899 V	33.2 kΩ	3.300 V	2.61 kΩ
0.919 V	30.1 kΩ	5.000 V	1.50 kΩ
0.965 V	25.5 kΩ		

5.4 Start-up Procedure

The ZL2006 follows a specific internal start-up procedure after power is applied to the VDD pin. Table 10 describes the start-up sequence.

If the device is to be synchronized to an external clock source, the clock frequency must be stable prior to asserting the EN pin. The device requires approximately 5-10 ms to check for specific values stored in its internal memory. If the user has stored values in memory, those values will be loaded. The device will then check the status of all multi-mode pins and load the values associated with the pin settings.

Once this process is completed, the device is ready to accept commands via the I²C/SMBus interface and the device is ready to be enabled. Once enabled, the device requires approximately 2 ms before its output voltage may be allowed to start its ramp-up process. If a soft-start delay period less than 2 ms has been configured (using DLY pins or PMBus commands), the device will default to a 2 ms delay period. If a delay period greater than 2 ms is configured, the device will wait for the configured delay period prior to starting to ramp its output.

After the delay period has expired, the output will begin to ramp towards its target voltage according to the pre-configured soft-start ramp time that has been set using the SS pin. It should be noted that if the EN pin is tied to VDD, the device will still require approx 5-10 ms before the output can begin its ramp-up as described in Table 10 below.

5.5 Soft Start Delay and Ramp Times

It may be necessary to set a delay from when an enable signal is received until the output voltage starts to ramp to its target value. In addition, the designer may wish to precisely set the time required for V_{OUT} to ramp to its target value after the delay period has expired. These features may be used as part of an overall inrush current management strategy or to precisely control how fast a load IC is turned on. The ZL2006 gives the system designer several options for precisely and independently controlling both the delay and ramp time periods.

The soft-start delay period begins when the EN pin is asserted and ends when the delay time expires. The soft-start delay period is set using the DLY (0,1) pins. Precise ramp delay timing reduces the delay time variations but is only available when the appropriate bit in the MISC_CONFIG register has been set. Please refer to Application Note AN33 for details.

The soft-start ramp timer enables a precisely controlled ramp to the nominal V_{OUT} value that begins once the delay period has expired. The ramp-up is guaranteed monotonic and its slope may be precisely set using the SS pin.

The soft start delay and ramp times can be set to standard values according to Table 11 and Table 12 respectively.

Table 10. ZL2006 Start-up Sequence

Step #	Step Name	Description	Time Duration
1	Power Applied	Input voltage is applied to the ZL2006's VDD pin	Depends on input supply ramp time
2	Internal Memory Check	The device will check for values stored in its internal memory. This step is also performed after a Restore command.	Approx 5-10 ms (device will ignore an enable signal or PMBus traffic during this period)
3	Multi-mode Pin Check	The device loads values configured by the multi-mode pins.	
4	Device Ready	The device is ready to accept an enable signal.	—
5	Pre-ramp Delay	The device requires approximately 2 ms following an enable signal and prior to ramping its output. Additional pre-ramp delay may be configured using the Delay pins.	Approximately 2 ms

Table 11. Soft Start Delay Settings

		DLY0		
		LOW	OPEN	HIGH
DLY1	LOW	0 ms ¹	1 ms ¹	2 ms
	OPEN	5 ms	10 ms	20 ms
	HIGH	50 ms	100 ms	200 ms

Note:

1. When the device is set to 0 ms or 1 ms delay, it will begin its ramp up after the internal circuitry has initialized (approx. 2 ms).

Table 12. Soft Start Ramp Settings

SS	Ramp Time
LOW	0 ms ²
OPEN	5 ms
HIGH	10 ms

Note:

2. When the device is set to 0 ms ramp, it will attempt to ramp as fast as the external load capacitance and loop settings will allow. It is generally recommended to set the soft-start ramp to a value greater than 500 μs to prevent inadvertent fault conditions due to excessive inrush current.

If the desired soft start delay and ramp times are not one of the values listed in Table 11 and Table 12, the times can be set to a custom value by connecting a resistor from the DLY0 or SS pin to SGND using the appropriate resistor value from Table 13. The value of this resistor is measured upon start-up or Restore and will not change if the resistor is varied after power has been applied to the ZL2006. See Figure 14 for typical connections using resistors.

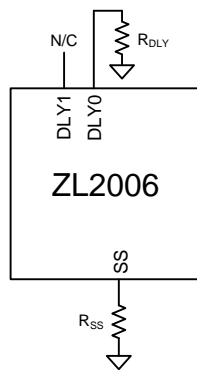

Figure 14. DLY and SS Pin Resistor Connections

Table 13. DLY and SS Resistor Settings

DLY or SS	R _{DLY} or R _{SS}	DLY or SS	R _{DLY} or R _{SS}
0 ms ²	10 kΩ	110 ms	28.7 kΩ
10 ms	11 kΩ	120 ms	31.6 kΩ
20 ms	12.1 kΩ	130 ms	34.8 kΩ
30 ms	13.3 kΩ	140 ms	38.3 kΩ
40 ms	14.7 kΩ	150 ms	42.2 kΩ
50 ms	16.2 kΩ	160 ms	46.4 kΩ
60 ms	17.8 kΩ	170 ms	51.1 kΩ
70 ms	19.6 kΩ	180 ms	56.2 kΩ
80 ms	21.5 kΩ	190 ms	61.9 kΩ
90 ms	23.7 kΩ	200 ms	68.1 kΩ
100 ms	26.1 kΩ		

Note: Do not connect a resistor to the DLY1 pin. This pin is not utilized for setting soft-start delay times. Connecting an external resistor to this pin may cause conflicts with other device settings.

The soft start delay and ramp times can also be set to custom values via the I²C/SMBus interface. When the SS delay time is set to 0 ms, the device will begin its ramp-up after the internal circuitry has initialized (approx. 2 ms). When the soft-start ramp period is set to 0 ms, the output will ramp up as quickly as the output load capacitance and loop settings will allow. It is generally recommended to set the soft-start ramp to a value greater than 500 μs to prevent inadvertent fault conditions due to excessive inrush current.

5.6 Power Good

The ZL2006 provides a Power Good (PG) signal that indicates the output voltage is within a specified tolerance of its target level and no fault condition exists. By default, the PG pin will assert if the output is within -10%/+15% of the target voltage. These limits and the polarity of the pin may be changed via the I²C/SMBus interface. See Application Note AN33 for details.

A PG delay period is defined as the time from when all conditions within the ZL2006 for asserting PG are met to when the PG pin is actually asserted. This feature is commonly used instead of using an external reset controller to control external digital logic. By default, the ZL2006 PG delay is set equal to the soft-start ramp time setting. Therefore, if the soft-start ramp time is set to 10 ms, the PG delay will be set to 10 ms. The PG delay may be set independently of the soft-start ramp using the I²C/SMBus as described in Application Note AN33.

5.7 Switching Frequency and PLL

The ZL2006 incorporates an internal phase-locked loop (PLL) to clock the internal circuitry. The PLL can be driven by an external clock source connected to the SYNC pin. When using the internal oscillator, the SYNC pin can be configured as a clock source for other Zilker Labs devices.

The SYNC pin is a unique pin that can perform multiple functions depending on how it is configured. The CFG pin is used to select the operating mode of the SYNC pin as shown in Table 14. Figure 15 illustrates the typical connections for each mode.

Table 14. SYNC Pin Function Selection

CFG Pin	SYNC Pin Function
LOW	SYNC is configured as an input
OPEN	Auto Detect mode
HIGH	SYNC is configured as an output $f_{sw} = 400 \text{ kHz}$

Configuration A: SYNC OUTPUT

When the SYNC pin is configured as an output (CFG pin is tied HIGH), the device will run from its internal oscillator and will drive the resulting internal oscillator signal (preset to 400 kHz) onto the SYNC pin so other devices can be synchronized to it. The SYNC pin will not be checked for an incoming clock signal while in this mode.

Configuration B: SYNC INPUT

When the SYNC pin is configured as an input (CFG pin is tied LOW), the device will automatically check for a clock signal on the SYNC pin each time EN is asserted. The ZL2006's oscillator will then synchronize with the rising edge of the external clock.

The incoming clock signal must be in the range of 200 kHz to 1.4 MHz and must be stable when the enable pin is asserted. The clock signal must also exhibit the necessary performance requirements (see Table 3). In the event of a loss of the external clock signal, the output voltage may show transient over/undershoot.

If this happens, the ZL2006 will automatically switch to its internal oscillator and switch at a frequency close to the previous incoming frequency.

Configuration C: SYNC AUTO DETECT

When the SYNC pin is configured in auto detect mode (CFG pin is left OPEN), the device will automatically check for a clock signal on the SYNC pin after enable is asserted.

If a clock signal is present, The ZL2006's oscillator will then synchronize the rising edge of the external clock. Refer to SYNC INPUT description.

If no incoming clock signal is present, the ZL2006 will configure the switching frequency according to the state of the SYNC pin as listed in Table 15. In this mode, the ZL2006 will only read the SYNC pin connection during the start-up sequence. Changes to SYNC pin connections will not affect f_{sw} until the power (VDD) is cycled off and on.

Table 15. Switching Frequency Selection

SYNC Pin	Frequency
LOW	200 kHz
OPEN	400 kHz
HIGH	1 MHz
Resistor	See Table 16

If the user wishes to run the ZL2006 at a frequency not listed in Table 15, the switching frequency can be set using an external resistor, R_{SYNC} , connected between SYNC and SGND using Table 16.

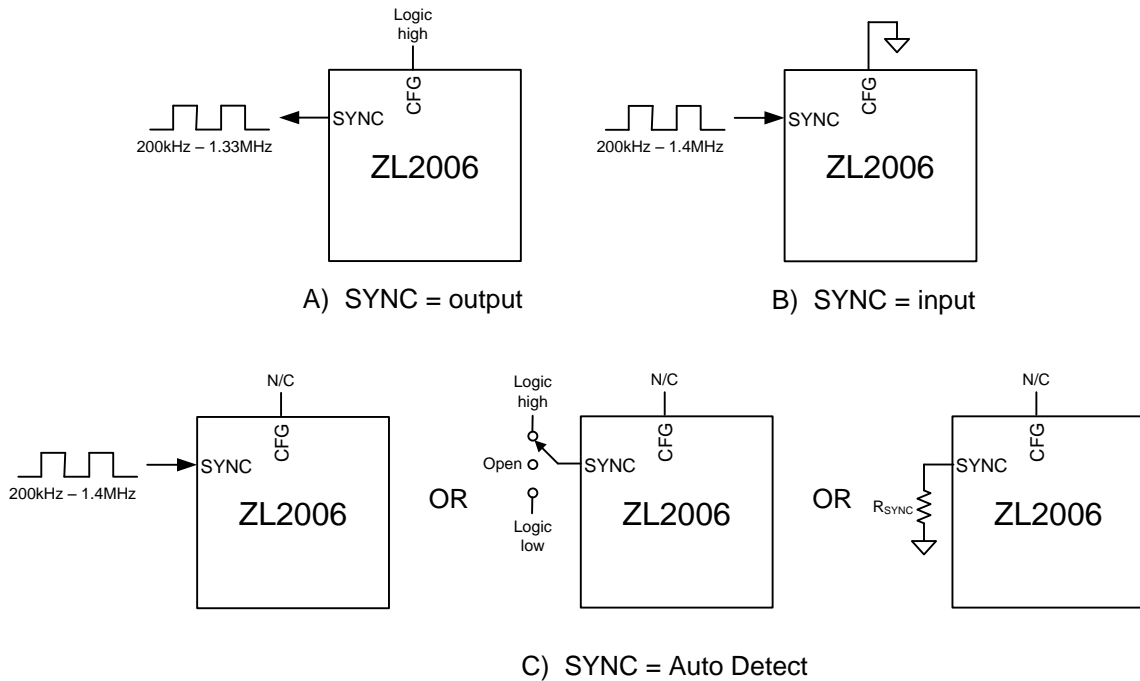

Figure 15. SYNC Pin Configurations

Table 16. R_{SYNC} Resistor Values

R _{SYNC}	f _{sw}	R _{SYNC}	f _{sw}
10 kΩ	200 kHz	26.1 kΩ	533 kHz
11 kΩ	222 kHz	28.7 kΩ	571 kHz
12.1 kΩ	242 kHz	31.6 kΩ	615 kHz
13.3 kΩ	267 kHz	34.8 kΩ	727 kHz
14.7 kΩ	296 kHz	38.3 kΩ	800 kHz
16.2 kΩ	320 kHz	46.4 kΩ	889 kHz
17.8 kΩ	364 kHz	51.1 kΩ	1000 kHz
19.6 kΩ	400 kHz	56.2 kΩ	1143 kHz
21.5 kΩ	421 kHz	68.1 kΩ	1333 kHz
23.7 kΩ	471 kHz		

The switching frequency can also be set to any value between 200 kHz and 1.33 MHz using the I²C/SMBus interface. The available frequencies below 1.4 MHz are defined by $f_{sw} = 8 \text{ MHz}/N$, where the whole number N is $6 \leq N \leq 40$. See Application Note AN33 for details.

If a value other than $f_{sw} = 8 \text{ MHz}/N$ is entered using a PMBus command, the internal circuitry will select the valid switching frequency value that is closest to the entered value. For example, if 810 kHz is entered, the device will select 800 kHz (N=10).

When multiple Zilker Labs devices are used together, connecting the SYNC pins together will force all devices to synchronize with each other. The CFG pin of one device must set its SYNC pin as an output and the remaining devices must have their SYNC pins set as Auto Detect.

Note: The switching frequency read back using the appropriate PMBus command will differ slightly from the selected values in Table 16. The difference is due to hardware quantization.

5.8 Power Train Component Selection

The ZL2006 is a synchronous buck converter that uses external MOSFETs, inductor and capacitors to perform the power conversion process. The proper selection of the external components is critical for optimized performance.

To select the appropriate external components for the desired performance goals, the power supply requirements listed in Table 17 must be known.

Table 17. Power Supply Requirements

Parameter	Range	Example Value
Input voltage (V_{IN})	3.0 – 14.0 V	12 V
Output voltage (V_{OUT})	0.6 – 5.0 V	1.2 V
Output current (I_{OUT})	0 to ~25 A	20 A
Output voltage ripple (V_{orip})	< 3% of V_{OUT}	1% of V_{OUT}
Output load step (I_{ostep})	< I_o	50% of I_o
Output load step rate	—	10 A/ μ S
Output deviation due to load step	—	\pm 50 mV
Maximum PCB temp.	120°C	85°C
Desired efficiency	—	85%
Other considerations	Various	Optimize for small size

5.8.1 Design Goal Trade-offs

The design of the buck power stage requires several compromises among size, efficiency, and cost. The inductor core loss increases with frequency, so there is a trade-off between a small output filter made possible by a higher switching frequency and getting better power supply efficiency. Size can be decreased by increasing the switching frequency at the expense of efficiency. Cost can be minimized by using through-hole inductors and capacitors; however these components are physically large.

To start the design, select a switching frequency based on Table 18. This frequency is a starting point and may be adjusted as the design progresses.

Table 18. Circuit Design Considerations

Frequency Range	Efficiency	Circuit Size
200–400 kHz	Highest	Larger
400–800 kHz	Moderate	Smaller
800 kHz – 1.4 MHz	Lower	Smallest

5.8.2 Inductor Selection

The output inductor selection process must include several trade-offs. A high inductance value will result in a low ripple current (I_{opp}), which will reduce output capacitance and produce a low output ripple voltage, but may also compromise output transient load performance. Therefore, a balance must be struck between output ripple and optimal load transient performance. A good starting point is to select the output inductor ripple equal to the expected load transient step magnitude (I_{ostep}):

$$I_{opp} = I_{ostep}$$

Now the output inductance can be calculated using the following equation, where V_{INM} is the maximum input voltage:

$$L_{OUT} = \frac{V_{OUT} \times \left(1 - \frac{V_{OUT}}{V_{INM}}\right)}{f_{SW} \times I_{opp}}$$

The average inductor current is equal to the maximum output current. The peak inductor current (I_{Lpk}) is calculated using the following equation where I_{OUT} is the maximum output current:

$$I_{Lpk} = I_{OUT} + \frac{I_{opp}}{2}$$

Select an inductor rated for the average DC current with a peak current rating above the peak current computed above.

In over-current or short-circuit conditions, the inductor may have currents greater than 2X the normal maximum rated output current. It is desirable to use an inductor that still provides some inductance to protect the load and the MOSFETs from damaging currents in this situation.

Once an inductor is selected, the DCR and core losses in the inductor are calculated. Use the DCR specified in the inductor manufacturer's datasheet.

$$P_{LDCR} = DCR \times I_{Lrms}^2$$

I_{Lrms} is given by

$$I_{Lrms} = \sqrt{I_{OUT}^2 + \frac{(I_{opp})^2}{12}}$$

where I_{OUT} is the maximum output current. Next, calculate the core loss of the selected inductor. Since this calculation is specific to each inductor and manufacturer, refer to the chosen inductor datasheet. Add the core loss and the ESR loss and compare the total loss to the maximum power dissipation recommendation in the inductor datasheet.

5.8.3 Output Capacitor Selection

Several trade-offs must also be considered when selecting an output capacitor. Low ESR values are needed to have a small output deviation during transient load steps (V_{osag}) and low output voltage ripple (V_{orip}). However, capacitors with low ESR, such as semi-stable (X5R and X7R) dielectric ceramic capacitors, also have relatively low capacitance values. Many designs can use a combination of high capacitance devices and low ESR devices in parallel.

For high ripple currents, a low capacitance value can cause a significant amount of output voltage ripple. Likewise, in high transient load steps, a relatively large amount of capacitance is needed to minimize the output voltage deviation while the inductor current ramps up or down to the new steady state output current value.

As a starting point, apportion one-half of the output ripple voltage to the capacitor ESR and the other half to capacitance, as shown in the following equations:

$$C_{OUT} = \frac{I_{opp}}{8 \times f_{sw} \times \frac{V_{orip}}{2}}$$

$$ESR = \frac{V_{orip}}{2 \times I_{opp}}$$

Use these values to make an initial capacitor selection, using a single capacitor or several capacitors in parallel.

After a capacitor has been selected, the resulting output voltage ripple can be calculated using the following equation:

$$V_{orip} = I_{opp} \times ESR + \frac{I_{opp}}{8 \times f_{sw} \times C_{OUT}}$$

Because each part of this equation was made to be less than or equal to half of the allowed output ripple voltage, the V_{orip} should be less than the desired maximum output ripple.

5.8.4 Input Capacitor

It is highly recommended that dedicated input capacitors be used in any point-of-load design, even when the supply is powered from a heavily filtered 5 or 12 V “bulk” supply from an off-line power supply. This is because of the high RMS ripple current that is drawn by the buck converter topology. This ripple (I_{CINrms}) can be determined from the following equation:

$$I_{CINrms} = I_{OUT} \times \sqrt{D \times (1 - D)}$$

Without capacitive filtering near the power supply circuit, this current would flow through the supply bus and return planes, coupling noise into other system circuitry. The input capacitors should be rated at 1.2X the ripple current calculated above to avoid overheating of the capacitors due to the high ripple current, which can cause premature failure. Ceramic capacitors with X7R or X5R dielectric with low ESR and 1.1X the maximum expected input voltage are recommended.

5.8.5 Bootstrap Capacitor Selection

The high-side driver boost circuit utilizes an external Schottky diode (D_B) and an external bootstrap capacitor (C_B) to supply sufficient gate drive for the high-side MOSFET driver. D_B should be a 20 mA, 30 V Schottky diode or equivalent device and C_B should be a 1 μ F ceramic type rated for at least 6.3V.

5.8.6 QL Selection

The bottom MOSFET should be selected primarily based on the device's $R_{DS(ON)}$ and secondarily based on its gate charge. To choose QL, use the following equation and allow 2–5% of the output power to be dissipated in the $R_{DS(ON)}$ of QL (lower output voltages and higher step-down ratios will be closer to 5%):

$$P_{QL} = 0.05 \times V_{OUT} \times I_{OUT}$$

Calculate the RMS current in QL as follows:

$$I_{botrms} = I_{Lrms} \times \sqrt{1-D}$$

Calculate the desired maximum $R_{DS(ON)}$ as follows:

$$R_{DS(ON)} = \frac{P_{QL}}{(I_{botrms})^2}$$

Note that the $R_{DS(ON)}$ given in the manufacturer's datasheet is measured at 25°C. The actual $R_{DS(ON)}$ in the end-use application will be much higher. For example, a Vishay Si7114 MOSFET with a junction temperature of 125°C has an $R_{DS(ON)}$ that is 1.4 times higher than the value at 25°C. Select a candidate MOSFET, and calculate the required gate drive current as follows:

$$I_g = f_{sw} \times Q_g$$

Keep in mind that the total allowed gate drive current for both QH and QL is 80 mA.

MOSFETs with lower $R_{DS(ON)}$ tend to have higher gate charge requirements, which increases the current and resulting power required to turn them on and off. Since the MOSFET gate drive circuits are integrated in the ZL2006, this power is dissipated in the ZL2006 according to the following equation:

$$P_{QL} = f_{sw} \times Q_g \times V_{INM}$$

5.8.7 QH Selection

In addition to the $R_{DS(ON)}$ loss and gate charge loss, QH also has switching loss. The procedure to select QH is similar to the procedure for QL. First, assign 2–5% of the output power to be dissipated in the $R_{DS(ON)}$ of QH using the equation for QL above. As was done with QL, calculate the RMS current as follows:

$$I_{toprms} = I_{Lrms} \times \sqrt{D}$$

Calculate a starting $R_{DS(ON)}$ as follows, in this example using 5%:

$$P_{QH} = 0.05 \times V_{OUT} \times I_{OUT}$$

$$R_{DS(ON)} = \frac{P_{QH}}{(I_{toprms})^2}$$

Select a MOSFET and calculate the resulting gate drive current. Verify that the combined gate drive current from QL and QH does not exceed 80 mA.

Next, calculate the switching time using:

$$t_{sw} = \frac{Q_g}{I_{gdr}}$$

where Q_g is the gate charge of the selected QH and I_{gdr} is the peak gate drive current available from the ZL2006.

Although the ZL2006 has a typical gate drive current of 3 A, use the minimum guaranteed current of 2 A for a conservative design. Using the calculated switching time, calculate the switching power loss in QH using:

$$P_{swtop} = V_{INM} \times t_{sw} \times I_{OUT} \times f_{sw}$$

The total power dissipated by QH is given by the following equation:

$$P_{QHtot} = P_{QH} + P_{swtop}$$

5.8.8 MOSFET Thermal Check

Once the power dissipations for QH and QL have been calculated, the MOSFETs junction temperature can be estimated. Using the junction-to-case thermal resistance (R_{th}) given in the MOSFET manufacturer's datasheet and the expected maximum printed circuit board temperature, calculate the junction temperature as follows:

$$T_{jmax} = T_{pcb} + (P_Q \times R_{th})$$

5.8.9 Current Sensing Components

Once the current sense method has been selected (Refer to Section 5.9, “Current Limit Threshold Selection,”), the components are selected as follows.

When using the inductor DCR sensing method, the user must also select an R/C network comprised of R_1 and C_L (see Figure 16).

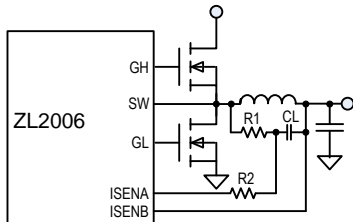

Figure 16. DCR Current Sensing

For the voltage across C_L to reflect the voltage across the DCR of the inductor, the time constant of the inductor must match the time constant of the RC network. That is:

$$\tau_{RC} = \tau_{L/DCR}$$

$$R_1 \cdot C_L = \frac{L}{DCR}$$

For L , use the average of the nominal value and the minimum value. Include the effects of tolerance, DC Bias and switching frequency on the inductance when determining the minimum value of L . Use the typical value for DCR .

The value of R_1 should be as small as feasible and no greater than 5 k Ω for best signal-to-noise ratio. The designer should make sure the resistor package size is appropriate for the power dissipated and include this loss in efficiency calculations. In calculating the minimum value of R_1 , the average voltage across C_L (which is the average $I_{OUT} \cdot DCR$ product) is small and can be neglected. Therefore, the minimum value of R_1 may be approximated by the following equation:

$$R_{1-\min} = \frac{D(V_{IN-\max} - V_{OUT})^2 + (1 - D) \cdot V_{OUT}^2}{P_{R1pkg-\max} \cdot \delta_P}$$

where $P_{R1pkg-\max}$ is the maximum power dissipation specification for the resistor package and δ_P is the derating factor for the same parameter (eg.: $P_{R1pkg-\max} = 0.0625\text{W}$ for 0603 package, $\delta_P = 50\%$ @ 85°C). Once $R_{1-\min}$ has been calculated, solve for the maximum value of C_L from

$$C_{L-\max} = \frac{L}{R_{1-\min} \cdot DCR}$$

and choose the next-lowest readily available value (eg.: For $C_{L-\max} = 1.86\mu\text{F}$, $C_L = 1.5\mu\text{F}$ is a good choice).

Then substitute the chosen value into the same equation and re-calculate the value of R_1 . Choose the 1% resistor standard value closest to this re-calculated value of R_1 . The error due to the mismatch of the two time constants is

$$\varepsilon_\tau = \left(1 - \frac{R_1 \cdot C_L \cdot DCR}{L_{avg}} \right) \cdot 100\%$$

The value of R_2 should be simply five times that of R_1 :

$$R_2 = 5 \cdot R_1$$

For the $R_{DS(ON)}$ current sensing method, the external low side MOSFET will act as the sensing element as indicated in Figure 17.

5.9 Current Limit Threshold Selection

It is recommended that the user include a current limiting mechanism in their design to protect the power supply from damage and prevent excessive current from being drawn from the input supply in the event that the output is shorted to ground or an overload condition is imposed on the output. Current limiting is accomplished by sensing the current through the circuit during a portion of the duty cycle.

Output current sensing can be accomplished by measuring the voltage across a series resistive sensing element according to the following equation:

$$V_{LIM} = I_{LIM} \times R_{SENSE}$$

Where:

I_{LIM} is the desired maximum current that should flow in the circuit

R_{SENSE} is the resistance of the sensing element

V_{LIM} is the voltage across the sensing element at the point the circuit should start limiting the output current.

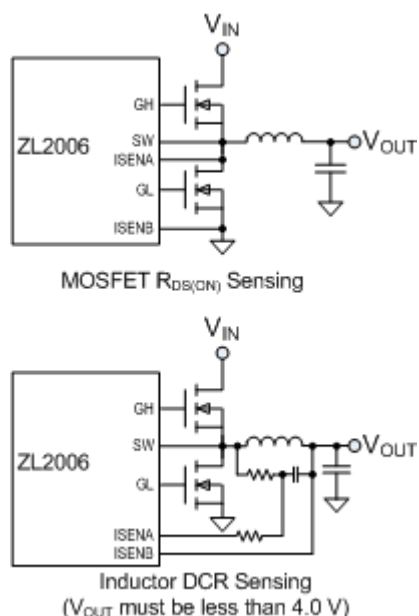

Figure 17. Current Sensing Methods

The ZL2006 supports “lossless” current sensing by measuring the voltage across a resistive element that is already present in the circuit. This eliminates additional efficiency losses incurred by devices that must use an additional series resistance in the circuit.

To set the current limit threshold, the user must first select a current sensing method. The ZL2006 incorporates two methods for current sensing, synchronous MOSFET $R_{DS(ON)}$ sensing and inductor DC resistance (DCR) sensing; Figure 17 shows a simplified schematic for each method.

The current sensing method can be selected using the ILIM1 pin using Table 19. The ILIM0 pin must have a finite resistor connected to ground in order for Table 19 to be valid. If no resistor is connected between ILIM0 and ground, the default method is MOSFET $R_{DS(ON)}$ sensing. The current sensing method can be modified via the I²C/SMBus interface. Please refer to Application Note AN33 for details.

In addition to selecting the current sensing method, the ZL2006 gives the power supply designer several choices for the fault response during over or under current condition. The user can select the number of violations allowed before declaring fault, a blanking time and the action taken when a fault is detected.

Table 19. Resistor Settings for Current Sensing

ILIM0 Pin ¹	ILIM1 Pin	Current Limiting Configuration	Number of Violations Allowed ²	Comments
R _{ILIM0}	LOW	Ground-referenced, $R_{DS(ON)}$, sensing Blanking time: 672 ns	5	Best for low duty cycle and low f_{sw}
R _{ILIM0}	OPEN	Output-referenced, down-slope sensing (Inductor DCR sensing) Blanking time: 352 ns	5	Best for low duty cycle and high f_{sw}
R _{ILIM0}	HIGH	Output-referenced, up-slope sensing (Inductor DCR sensing) Blanking time: 352 ns	5	Best for high duty cycle
	Resistor	Depends on resistor value used; see Table 20		

Notes:

1. $10\text{ k}\Omega < R_{ILIM0} < 100\text{ k}\Omega$
2. The number of violations allowed prior to issuing a fault response.

Table 20. Resistor Configured Current Sensing Method Selection

R_{LIM1}	Current Sensing Method	Number of Violations Allowed ¹
10 k Ω	Ground-referenced, $R_{DS(ON)}$, sensing Best for low duty cycle and low f_{sw} Blanking time: 672 ns	1
11 k Ω		3
12.1 k Ω		5
13.3 k Ω		7
14.7 k Ω		9
16.2 k Ω		11
17.8 k Ω		13
19.6 k Ω		15
21.5 k Ω	Output-referenced, down-slope sensing (Inductor DCR sensing) Best for low duty cycle and high f_{sw} Blanking time: 352 ns	1
23.7 k Ω		3
26.1 k Ω		5
28.7 k Ω		7
31.6 k Ω		9
34.8 k Ω		11
38.3 k Ω		13
42.2 k Ω		15
46.4 k Ω	Output-referenced, up-slope sensing (Inductor DCR sensing) Best for high duty cycle Blanking time: 352 ns	1
51.1 k Ω		3
56.2 k Ω		5
61.9 k Ω		7
68.1 k Ω		9
75 k Ω		11
82.5 k Ω		13
90.9 k Ω		15

Notes:

1. The number of violations allowed prior to issuing a fault response

The blanking time represents the time when no current measurement is taken. This is to avoid taking a reading just after a current load step (Less accurate due to potential ringing). It is a configurable parameter.

Table 19 includes default parameters for the number of violations and the blanking time using pin-strap.

Once the sensing method has been selected, the user must select the voltage threshold (VLIM), the desired current limit threshold, and the resistance of the sensing element.

The current limit threshold can be selected by simply connecting the ILIM0 and ILIM1 pins as shown in Table 21. The ground-referenced sensing method is being used in this mode.

Table 21. Current Limit Threshold Voltage Pin-strap Settings

		ILIM0		
		LOW	OPEN	HIGH
ILIM1	LOW	20 mV	30 mV	40 mV
	OPEN	50 mV	60 mV	70 mV
	HIGH	80 mV	90 mV	100 mV

The threshold voltage can also be selected in 5 mV increments by connecting a resistor, R_{LIM0} , between the ILIM0 pin and ground according to Table 22. This method is preferred if the user does not desire to use or does not have access to the I²C/SMBus interface and the desired threshold value is contained in Table 22.

The current limit threshold can also be set to a custom value via the I²C/SMBus interface. Please refer to Application Note AN33 for further details.

Table 22. Current Limit Threshold Voltage Resistor Settings

R_{LIM0}	V_{LIM} for RDS	V_{LIM} for DCR
10 k Ω	0 mV	0 mV
11 k Ω	5 mV	2.5 mV
12.1 k Ω	10 mV	5 mV
13.3 k Ω	15 mV	7.5 mV
14.7 k Ω	20 mV	10 mV
16.2 k Ω	25 mV	12.5 mV
17.8 k Ω	30 mV	15 mV
19.6 k Ω	35 mV	17.5 mV
21.5 k Ω	40 mV	20 mV
23.7 k Ω	45 mV	22.5 mV
26.1 k Ω	50 mV	25 mV
28.7 k Ω	55 mV	27.5 mV
31.6 k Ω	60 mV	30 mV
34.8 k Ω	65 mV	32.5 mV
38.3 k Ω	70 mV	35 mV
46.4 k Ω	80 mV	40 mV
51.1 k Ω	85 mV	42.5 mV
56.2 k Ω	90 mV	45 mV
68.1 k Ω	100 mV	50 mV
82.5 k Ω	110 mV	55 mV
100 k Ω	120 mV	60 mV

5.10 Loop Compensation

The ZL2006 operates as a voltage-mode synchronous buck controller with a fixed frequency PWM scheme. Although the ZL2006 uses a digital control loop, it operates much like a traditional analog PWM controller. Figure 18 is a simplified block diagram of the ZL2006 control loop, which differs from an analog control loop only by the constants in the PWM and compensation blocks. As in the analog controller case, the compensation block compares the output voltage to the desired voltage reference and compensation zeroes are added to keep the loop stable. The resulting integrated error signal is used to drive the PWM logic, converting the error signal to a duty cycle to drive the external MOSFETs.

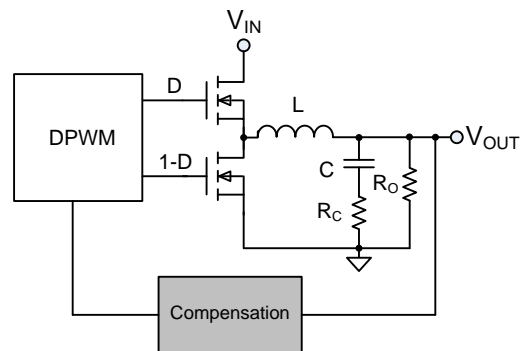
**Figure 18. Control Loop Block Diagram**

In the ZL2006, the compensation zeros are set by configuring the FC0 and FC1 pins or via the I²C/SMBus interface once the user has calculated the required settings. This method eliminates the inaccuracies due to the component tolerances associated with using external resistors and capacitors required with traditional analog controllers. Utilizing the loop compensation settings shown in Table 23 will yield a conservative crossover frequency at a fixed fraction of the switching frequency ($f_{sw}/20$) and 60° of phase margin.

Step 1: Using the following equation, calculate the resonant frequency of the LC filter, f_n .

$$f_n = \frac{1}{2\pi\sqrt{L \times C}}$$

Step 2: Based on Table 23 determine the FC0 settings.

Step 3: Calculate the ESR zero frequency (f_{ZESR}).

$$f_{zesr} = \frac{1}{2\pi CRc}$$

Step 4: Based on Table 23 determine the FC1 setting.

5.11 Adaptive Compensation

Loop compensation can be a time-consuming process, forcing the designer to accommodate design trade-offs related to performance and stability across a wide range of operating conditions. The ZL2006 offers an adaptive compensation mode that enables the user to increase the stability over a wider range of loading conditions by automatically adapting the loop compensation coefficients for changes in load current.

Setting the loop compensation coefficients through the I²C/SMBus interface allows for a second set of coefficients to be stored in the device in order to utilize adaptive loop compensation. This algorithm uses the two sets of compensation coefficients to determine optimal compensation settings as the output load changes. Please refer to Application Note AN33 for further details on PMBus commands.

Table 23. Pin-strap Settings for Loop Compensation

FC0 Range	FC0 Pin	FC1 Range	FC1 Pin
$f_{sw}/60 < f_n < f_{sw}/30$	HIGH	$f_{zesr} > f_{sw}/10$	HIGH
		$f_{sw}/10 > f_{zesr} > f_{sw}/30$	OPEN
		Reserved	LOW
$f_{sw}/120 < f_n < f_{sw}/60$	OPEN	$f_{zesr} > f_{sw}/10$	HIGH
		$f_{sw}/10 > f_{zesr} > f_{sw}/30$	OPEN
		Reserved	LOW
$f_{sw}/240 < f_n < f_{sw}/120$	LOW	$f_{zesr} > f_{sw}/10$	HIGH
		$f_{sw}/10 > f_{zesr} > f_{sw}/30$	OPEN
		Reserved	LOW

5.12 Non-linear Response (NLR) Settings

The ZL2006 incorporates a non-linear response (NLR) loop that decreases the response time and the output voltage deviation in the event of a sudden output load current step. The NLR loop incorporates a secondary error signal processing path that bypasses the primary error loop when the output begins to transition outside of the standard regulation limits. This scheme results in a higher equivalent loop bandwidth than what is possible using a traditional linear loop.

When a load current step function imposed on the output causes the output voltage to drop below the lower regulation limit, the NLR circuitry will force a positive correction signal that will turn on the upper MOSFET and quickly force the output to increase. Conversely, a negative load step (i.e. removing a large load current) will cause the NLR circuitry to force a negative correction signal that will turn on the lower MOSFET and quickly force the output to decrease.

The ZL2006 has been pre-configured with appropriate NLR settings that correspond to the loop compensation settings in Table 23. Please refer to Application Note AN32 for more details regarding NLR settings.

5.13 Efficiency Optimized Driver Dead-time Control

The ZL2006 utilizes a closed loop algorithm to optimize the dead-time applied between the gate drive signals for the top and bottom FETs. In a synchronous buck converter, the MOSFET drive circuitry must be designed such that the top and bottom MOSFETs are never in the conducting state at the same time. Potentially damaging currents flow in the circuit if both top and bottom MOSFETs are simultaneously on for periods of time exceeding a few nanoseconds. Conversely, long periods of time in which both MOSFETs are off reduce overall circuit efficiency by allowing current to flow in their parasitic body diodes.

It is therefore advantageous to minimize this dead-time to provide optimum circuit efficiency. In the first order model of a buck converter, the duty cycle is determined by the equation:

$$D \approx \frac{V_{OUT}}{V_{IN}}$$

However, non-idealities exist that cause the real duty cycle to extend beyond the ideal. Dead-time is one of those non-idealities that can be manipulated to

improve efficiency. The ZL2006 has an internal algorithm that constantly adjusts dead-time non-overlap to minimize duty cycle, thus maximizing efficiency. This circuit will null out dead-time differences due to component variation, temperature, and loading effects.

This algorithm is independent of application circuit parameters such as MOSFET type, gate driver delays, rise and fall times and circuit layout. In addition, it does not require drive or MOSFET voltage or current waveform measurements.

5.14 Adaptive Diode Emulation

Most power converters use synchronous rectification to optimize efficiency over a wide range of input and output conditions. However, at light loads the synchronous MOSFET will typically sink current and introduce additional energy losses associated with higher peak inductor currents, resulting in reduced efficiency. Adaptive diode emulation mode turns off the low-side FET gate drive at low load currents to prevent the inductor current from going negative, reducing the energy losses and increasing overall efficiency. Diode emulation is available to single-phase devices or current sharing devices that have dropped all but a single phase.

Note: the overall bandwidth of the device may be reduced when in diode emulation mode. It is recommended that diode emulation is disabled prior to applying significant load steps.

5.15 Adaptive Frequency Control

Since switching losses contribute to the efficiency of the power converter, reducing the switching frequency will reduce the switching losses and increase efficiency. The ZL2006 includes Adaptive Frequency Control mode, which effectively reduces the observed switching frequency as the load decreases.

Adaptive frequency mode is enabled by setting bit 0 of MISC_CONFIG to 1 and is only available while the device is operating within Adaptive Diode Emulation Mode. As the load current is decreased, diode emulation mode decreases the GL on-time to prevent negative inductor current from flowing. As the load is decreased further, the GH pulse width will begin to decrease while maintaining the programmed frequency, f_{PROG} (set by the `FREQ_SWITCH` command).

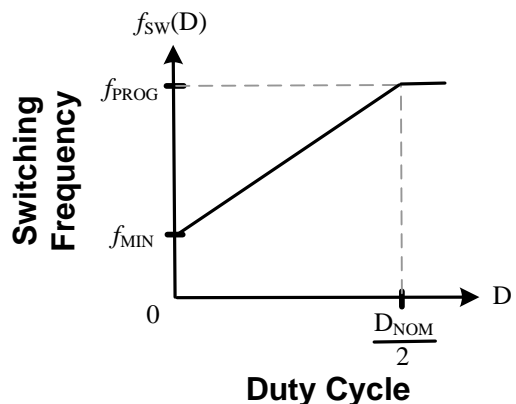

Figure 19. Adaptive Frequency

Once the GH pulse width (D) reaches 50% of the nominal duty cycle, D_{NOM} (determined by V_{in} and V_{out}), the switching frequency will start to decrease according to the following equation:

$$\text{If } D < \frac{D_{NOM}}{2} \text{ then}$$

$$f_{sw}(D) = \left(\frac{2(f_{sw} - f_{MIN})}{D_{NOM}} \right) D + f_{MIN}$$

Otherwise $f_{sw}(D) = f_{PROG}$

This is illustrated in Figure 19. Due to quantizing effects inside the IC, the ZL2006 will decrease its frequency in steps between f_{sw} and f_{MIN} . The quantity and magnitude of the steps will depend on the difference between f_{sw} and f_{MIN} as well as the frequency range.

It should be noted that adaptive frequency mode is not available for current sharing groups and is not allowed when the device is placed in auto-detect mode and a clock source is present on the SYNC pin, or if the device is outputting a clock signal on its SYNC pin.

6. Power Management Functional Description

6.1 Input Undervoltage Lockout

The input undervoltage lockout (UVLO) prevents the ZL2006 from operating when the input falls below a preset threshold, indicating the input supply is out of its specified range. The UVLO threshold (V_{UVLO}) can be set between 2.85 V and 16 V using the UVLO pin. The simplest implementation is to connect the UVLO pin as shown in Table 24. If the UVLO pin is left unconnected, the UVLO threshold will default to 4.5 V.

Table 24. UVLO Threshold Settings

Pin Setting	UVLO Threshold
LOW	3 V
OPEN	4.5 V
HIGH	10.8 V

If the desired UVLO threshold is not one of the listed choices, the user can configure a threshold between 2.85 V and 16 V by connecting a resistor between the UVLO pin and SGND by selecting the appropriate resistor from Table 25.

Table 25. UVLO Resistor Values

R_{UVLO}	UVLO	R_{UVLO}	UVLO
17.8 k Ω	2.85 V	46.4 k Ω	7.42 V
19.6 k Ω	3.14 V	51.1 k Ω	8.18 V
21.5 k Ω	3.44 V	56.2 k Ω	8.99 V
23.7 k Ω	3.79 V	61.9 k Ω	9.9 V
26.1 k Ω	4.18 V	68.1 k Ω	10.9 V
28.7 k Ω	4.59 V	75 k Ω	12 V
31.6 k Ω	5.06 V	82.5 k Ω	13.2 V
34.8 k Ω	5.57 V	90.9 k Ω	14.54 V
38.3 k Ω	6.13 V	100 k Ω	16 V
42.2 k Ω	6.75 V		

The UVLO voltage can also be set to any value between 2.85 V and 16 V via the I²C/SMBus interface.

Once an input undervoltage fault condition occurs, the device can respond in a number of ways as follows:

1. Continue operating without interruption.
2. Continue operating for a given delay period, followed by shutdown if the fault still exists. The device will remain in shutdown until instructed to restart.
3. Initiate an immediate shutdown until the fault has been cleared. The user can select a specific number of retry attempts.

The default response from a UVLO fault is an immediate shutdown of the device. The device will continuously check for the presence of the fault condition. If the fault condition is no longer present, the ZL2006 will be re-enabled.

Please refer to Application Note AN33 for details on how to configure the UVLO threshold or to select specific UVLO fault response options via the I²C/SMBus interface.

6.2 Output Overvoltage Protection

The ZL2006 offers an internal output overvoltage protection circuit that can be used to protect sensitive load circuitry from being subjected to a voltage higher than its prescribed limits. A hardware comparator is used to compare the actual output voltage (seen at the VSEN pin) to a threshold set to 15% higher than the target output voltage (the default setting). If the VSEN voltage exceeds this threshold, the PG pin will de-assert and the device can then respond in a number of ways as follows:

1. Initiate an immediate shutdown until the fault has been cleared. The user can select a specific number of retry attempts.
2. Turn off the high-side MOSFET and turn on the low-side MOSFET. The low-side MOSFET remains ON until the device attempts a restart.

The default response from an overvoltage fault is to immediately shut down. The device will continuously check for the presence of the fault condition, and when the fault condition no longer exists the device will be re-enabled.

For continuous overvoltage protection when operating from an external clock, the only allowed response is an immediate shutdown.

Please refer to Application Note AN33 for details on how to select specific overvoltage fault response options via I²C/SMBus.

6.3 Output Pre-Bias Protection

An output pre-bias condition exists when an externally applied voltage is present on a power supply's output before the power supply's control IC is enabled. Certain applications require that the converter not be allowed to sink current during start up if a pre-bias condition exists at the output. The ZL2006 provides pre-bias protection by sampling the output voltage prior to initiating an output ramp.

If a pre-bias voltage lower than the target voltage exists after the pre-configured delay period has expired, the target voltage is set to match the existing pre-bias voltage and both drivers are enabled. The output voltage is then ramped to the final regulation value at the ramp rate set by the SS pin.

The actual time the output will take to ramp from the pre-bias voltage to the target voltage will vary depending on the pre-bias voltage but the total time elapsed from when the delay period expires and when the output reaches its target value will match the pre-configured ramp time. See Figure 20.

If a pre-bias voltage higher than the target voltage exists after the pre-configured delay period has expired, the target voltage is set to match the existing pre-bias voltage and both drivers are enabled with a PWM duty cycle that would ideally create the pre-bias voltage.

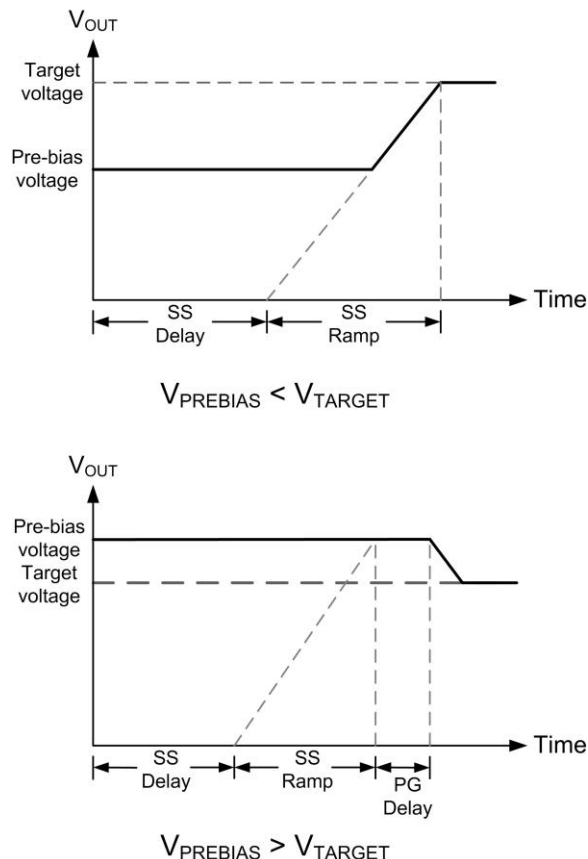

Figure 20. Output Responses to Pre-bias Voltages

Once the pre-configured soft-start ramp period has expired, the PG pin will be asserted (assuming the pre-bias voltage is not higher than the overvoltage limit). The PWM will then adjust its duty cycle to match the original target voltage and the output will ramp down to the pre-configured output voltage.

If a pre-bias voltage higher than the overvoltage limit exists, the device will not initiate a turn-on sequence and will declare an overvoltage fault condition to exist. In this case, the device will respond based on the output overvoltage fault response method that has been selected. See Section 6.2 “Output Overvoltage Protection,” for response options due to an overvoltage condition.

Pre-bias protection is not offered for current sharing groups that also have tracking enabled.

6.4 Output Overcurrent Protection

The ZL2006 can protect the power supply from damage if the output is shorted to ground or if an overload condition is imposed on the output. Once the current limit threshold has been selected (see Section 5.9 “Current Limit Threshold Selection”), the user may determine the desired course of action in response to the fault condition. The following overcurrent protection response options are available:

1. Initiate a shutdown and attempt to restart an infinite number of times with a preset delay period between attempts.
2. Initiate a shutdown and attempt to restart a preset number of times with a preset delay period between attempts.
3. Continue operating for a given delay period, followed by shutdown if the fault still exists.
4. Continue operating through the fault (this could result in permanent damage to the power supply).
5. Initiate an immediate shutdown.

The default response from an overcurrent fault is an immediate shutdown of the device. The device will continuously check for the presence of the fault condition, and if the fault condition no longer exists the device will be re-enabled.

Please refer to Application Note AN33 for details on how to select specific overcurrent fault response options via I²C/SMBus.

6.5 Thermal Overload Protection

The ZL2006 includes an on-chip thermal sensor that continuously measures the internal temperature of the die and shuts down the device when the temperature exceeds the preset limit. The default temperature limit is set to 125°C in the factory, but the user may set the limit to a different value if desired. See Application Note AN33 for details. Note that setting a higher thermal limit via the I²C/SMBus interface may result in permanent damage to the device. Once the device has been disabled due to an internal temperature fault, the user may select one of several fault response options as follows:

1. Initiate a shutdown and attempt to restart an infinite number of times with a preset delay period between attempts.

2. Initiate a shutdown and attempt to restart a preset number of times with a preset delay period between attempts.
3. Continue operating for a given delay period, followed by shutdown if the fault still exists.
4. Continue operating through the fault (this could result in permanent damage to the power supply).
5. Initiate an immediate shutdown.

If the user has configured the device to restart, the device will wait the preset delay period (if configured to do so) and will then check the device temperature. If the temperature has dropped below a threshold that is approx 15°C lower than the selected temperature fault limit, the device will attempt to re-start. If the temperature still exceeds the fault limit the device will wait the preset delay period and retry again.

The default response from a temperature fault is an immediate shutdown of the device. The device will continuously check for the fault condition, and once the fault has cleared the ZL2006 will be re-enabled.

Please refer to Application Note AN33 for details on how to select specific temperature fault response options via I²C/SMBus.

6.6 Voltage Tracking

Numerous high performance systems place stringent demands on the order in which the power supply voltages are turned on. This is particularly true when powering FPGAs, ASICs, and other advanced processor devices that require multiple supply voltages to power a single die. In most cases, the I/O interface operates at a higher voltage than the core and therefore the core supply voltage must not exceed the I/O supply voltage according to the manufacturers' specifications.

Voltage tracking protects these sensitive ICs by limiting the differential voltage between multiple power supplies during the power-up and power down sequence. The ZL2006 integrates a lossless tracking scheme that allows its output to track a voltage that is applied to the VTRK pin with no external components required. The VTRK pin is an analog input that, when tracking mode is enabled, configures the voltage applied to the VTRK pin to act as a reference for the device's output regulation.

The ZL2006 offers two mode of tracking as follows:

1. *Coincident*. This mode configures the ZL2006 to ramp its output voltage at the same rate as the voltage applied to the VTRK pin.
2. *Ratiometric*. This mode configures the ZL2006 to ramp its output voltage at a rate that is a percentage of the voltage applied to the VTRK pin. The default setting is 50%, but an external resistor string may be used to configure a different tracking ratio.

Figure 21 illustrates the typical connection and the two tracking modes.

The master ZL2006 device in a tracking group is defined as the device that has the highest target output voltage within the group. This master device will control the ramp rate of all tracking devices and is not configured for tracking mode. A delay of at least 10 ms must be configured into the master device using the DLY(0,1) pins, and the user may also configure a specific ramp rate using the SS pin. Any device that is configured for tracking mode will ignore its soft-start delay and ramp time settings (SS and DLY(0,1) pins) and its output will take on the turn-on/turn-off characteristics of the reference voltage present at the VTRK pin. All of the ENABLE pins in the tracking group must be connected together and driven by a single logic source. Tracking is configured via the I²C/SMBus interface by using the TRACK_CONFIG PMBus command. Please refer to Application Note AN33 for more information on configuring tracking mode using PMBus.

It should be noted that current sharing groups that are also configured to track another voltage do not offer pre-bias protection; a minimum load should therefore be enforced to avoid the output voltage from being held up by an outside force. Additionally, a device set up for tracking must have both Alternate Ramp Control and Precise Ramp-Up Delay disabled.

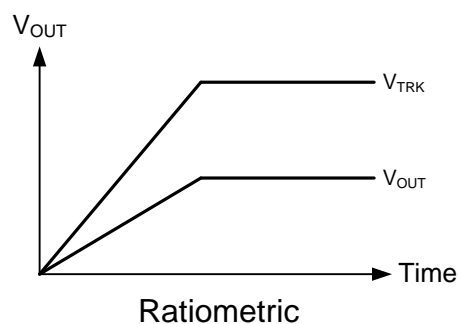
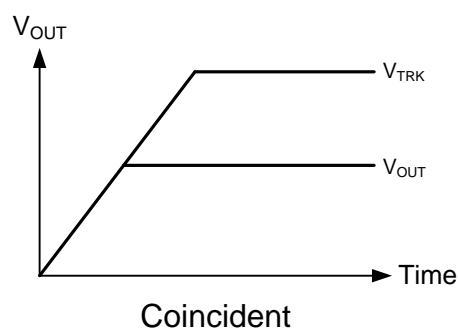
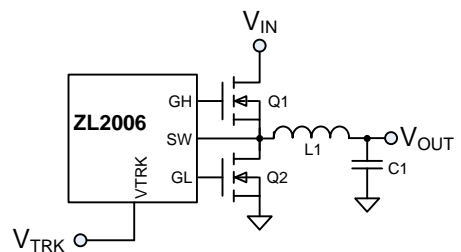

Figure 21. Tracking Modes

6.7 Voltage Margining

The ZL2006 offers a simple means to vary its output higher or lower than its nominal voltage setting in order to determine whether the load device is capable of operating over its specified supply voltage range. The MGN command is set by driving the MGN pin or through the I²C/SMBus interface. The MGN pin is a tri-level input that is continuously monitored and can be driven directly by a processor I/O pin or other logic-level output.

The ZL2006's output will be forced higher than its nominal set point when the MGN command is set HIGH, and the output will be forced lower than its nominal set point when the MGN command is set LOW. Default margin limits of $V_{NOM} \pm 5\%$ are pre-loaded in the factory, but the margin limits can be modified through the I²C/SMBus interface to as high as $V_{NOM} + 10\%$ or as low as 0V, where V_{NOM} is the nominal output voltage set point determined by the V0 and V1 pins. A safety feature prevents the user from configuring the output voltage to exceed $V_{NOM} + 10\%$ under any conditions.

The margin limits and the MGN command can both be set individually through the I²C/SMBus interface. Additionally, the transition rate between the nominal output voltage and either margin limit can be configured through the I²C interface. Please refer to Application Note AN33 for detailed instructions on modifying the margining configurations.

6.8 I²C/SMBus Communications

The ZL2006 provides an I²C/SMBus digital interface that enables the user to configure all aspects of the device operation as well as monitor the input and output parameters. The ZL2006 can be used with any standard 2-wire I²C host device. In addition, the device is compatible with SMBus version 2.0 and includes an SALRT line to help mitigate bandwidth limitations related to continuous fault monitoring. Pull-up resistors are required on the I²C/SMBus as specified in the SMBus 2.0 specification. The ZL2006 accepts most standard PMBus commands. When controlling the device with PMBus commands, it is recommended that the enable pin is tied to SGND.

6.9 I²C/SMBus Device Address Selection

When communicating with multiple SMBus devices using the I²C/SMBus interface, each device must have its own unique address so the host can distinguish between the devices. The device address can be set according to the pin-strap options listed in Table 26. Address values are right-justified.

Table 26. SMBus Device Address Selection

		SA0		
		LOW	OPEN	HIGH
SA1	LOW	0x20	0x21	0x22
	OPEN	0x23	0x24	0x25
	HIGH	0x26	0x27	Reserved

If additional device addresses are required, a resistor can be connected to the SA0 pin according to Table 27 to provide up to 25 unique device addresses. In this case, the SA1 pin should be tied to SGND.

Table 27. SMBus Address Values

R _{SA}	SMBus Address	R _{SA}	SMBus Address
10 kΩ	0x00	34.8 kΩ	0x0D
11 kΩ	0x01	38.3 kΩ	0x0E
12.1 kΩ	0x02	42.2 kΩ	0x0F
13.3 kΩ	0x03	46.4 kΩ	0x10
14.7 kΩ	0x04	51.1 kΩ	0x11
16.2 kΩ	0x05	56.2 kΩ	0x12
17.8 kΩ	0x06	61.9 kΩ	0x13
19.6 kΩ	0x07	68.1 kΩ	0x14
21.5 kΩ	0x08	75 kΩ	0x15
23.7 kΩ	0x09	82.5 kΩ	0x16
26.1 kΩ	0x0A	90.9 kΩ	0x17
28.7 kΩ	0x0B	100 kΩ	0x18
31.6 kΩ	0x0C		

If more than 25 unique device addresses are required or if other SMBus address values are desired, both the SA0 and SA1 pins can be configured with a resistor to SGND according to the following equation and Table 28.

$$\text{SMBus address} = 25 \times (\text{SA1 index}) + (\text{SA0 index})$$

(in decimal)

Using this method, the user can theoretically configure up to 625 unique SMBus addresses, however the SMBus is inherently limited to 128 devices so attempting to configure an address higher than 128 (0x80) will cause the device address to repeat (i.e, attempting to configure a device address of 129 (0x81) would result in a device address of 1). Therefore, the user should use index values 0-4 on the SA1 pin and the full range of index values on the SA0 pin, which will provide 125 device address combinations.

Table 28. SMBus Address Index Values

R _{SA}	SA0 or SA1 Index	R _{SA}	SA0 or SA1 Index
10 kΩ	0	34.8 kΩ	13
11 kΩ	1	38.3 kΩ	14
12.1 kΩ	2	42.2 kΩ	15
13.3 kΩ	3	46.4 kΩ	16
14.7 kΩ	4	51.1 kΩ	17
16.2 kΩ	5	56.2 kΩ	18
17.8 kΩ	6	61.9 kΩ	19
19.6 kΩ	7	68.1 kΩ	20
21.5 kΩ	8	75 kΩ	21
23.7 kΩ	9	82.5 kΩ	22
26.1 kΩ	10	90.9 kΩ	23
28.7 kΩ	11	100 kΩ	24
31.6 kΩ	12		

To determine the SA0 and SA1 resistor values given an SMBus address (in decimal), follow the steps below to calculate an index value and then use Table 28 to select the resistor that corresponds to the calculated index value as follows:

1. Calculate SA1 Index:

$$\text{SA1 Index} = \text{Address (in decimal)} \div 25$$

2. Round the result down to the nearest whole number.
3. Select the value of R1 from Table 28 using the SA1 Index rounded value from step 2.
4. Calculate SA0 Index:

$$\text{SA0 Index} = \text{Address} - (25 \times \text{SA1 Index})$$
5. Select the value of R0 from Table 28 using the SA0 Index value from step 4.

6.10 Digital-DC Bus

The Digital-DC (DDC) communications bus is used to communicate between Zilker Labs Digital-DC devices. This dedicated bus provides the communication channel between devices for features such as sequencing, fault spreading, and current sharing. The DDC pin on all Digital-DC devices in an application should be connected together. A pull-up resistor is required on the DDC bus in order to guarantee the rise time as follows:

$$\text{Rise time} = R_{\text{PU}} * C_{\text{LOAD}} \approx 1 \mu\text{s},$$

where R_{PU} is the DDC bus pull-up resistance and C_{LOAD} is the bus loading. The pull-up resistor may be tied to VR or to an external 3.3 V or 5 V supply as long as this voltage is present prior to or during device power-up. As rules of thumb, each device connected to the DDC bus presents approx 10 pF of capacitive loading, and each inch of FR4 PCB trace introduces approx 2 pF. The ideal design will use a central pull-up resistor that is well-matched to the total load capacitance. In power module applications, the user should consider whether to place the pull-up resistor on the module or on the PCB of the end application. The minimum pull-up resistance should be limited to a value that enables any device to assert the bus to a voltage that will ensure a logic 0 (typically 0.8 V at the device monitoring point) given the pull-up voltage (5 V if tied to VR) and the pull-down current capability of the ZL2006 (nominally 4 mA).

6.11 Phase Spreading

When multiple point of load converters share a common DC input supply, it is desirable to adjust the clock phase offset of each device such that not all devices start to switch simultaneously. Setting each converter to start its switching cycle at a different point in time can dramatically reduce input capacitance requirements and efficiency losses. Since the peak current drawn from the input supply is effectively spread out over a period of time, the peak current drawn at any given moment is reduced and the power losses proportional to the I_{RMS}^2 are reduced dramatically.

In order to enable phase spreading, all converters must be synchronized to the same switching clock. The CFG pin is used to set the configuration of the SYNC pin for each device as described in Section 5.7 “Switching Frequency and PLL” on Page 20.

Selecting the phase offset for the device is accomplished by selecting a device address according to the following equation:

$$\text{Phase offset} = \text{device address} \times 45^\circ$$

For example:

- A device address of 0x00 or 0x20 would configure no phase offset
- A device address of 0x01 or 0x21 would configure 45° of phase offset
- A device address of 0x02 or 0x22 would configure 90° of phase offset

The phase offset of each device may also be set to any value between 0° and 360° in 22.5° increments via the I²C/SMBus interface. Refer to Application Note AN33 for further details.

6.12 Output Sequencing

A group of Digital-DC devices may be configured to power up in a predetermined sequence. This feature is especially useful when powering advanced processors, FPGAs, and ASICs that require one supply to reach its operating voltage prior to another supply reaching its operating voltage in order to avoid latch-up from occurring. Multi-device sequencing can be achieved by configuring each device through the I²C/SMBus interface or by using Zilker Labs patented autonomous sequencing mode.

Autonomous sequencing mode configures sequencing by using events transmitted between devices over the DDC bus. This mode is not available on current sharing rails.

The sequencing order is determined using each device’s SMBus address. Using autonomous sequencing mode (configured using the CFG pin), the devices must be assigned sequential SMBus addresses with no missing addresses in the chain. This mode will also constrain each device to have a phase offset according to its SMBus address as described in Section 6.11 “Phase Spreading”.

The sequencing group will turn on in order starting with the device with the lowest SMBus address and

will continue through to turn on each device in the address chain until all devices connected have been turned on. When turning off, the device with the highest SMBus address will turn off first followed in reverse order by the other devices in the group.

Sequencing is configured by connecting a resistor from the CFG pin to ground as described in Table 29. The CFG pin is also used to set the configuration of the SYNC pin as well as to determine the sequencing method and order. Please refer to 5.7 “Switching Frequency and PLL” for more details on the operating parameters of the SYNC pin.

Multiple device sequencing may also be achieved by issuing PMBus commands to assign the preceding device in the sequencing chain as well as the device that will follow in the sequencing chain. This method places fewer restrictions on SMBus address (no need of sequential address) and also allows the user to assign any phase offset to any device irrespective of its SMBus device address.

The Enable pins of all devices in a sequencing group must be tied together and driven high to initiate a sequenced turn-on of the group. Enable must be driven low to initiate a sequenced turnoff of the group.

Refer to Application Note AN33 for details on sequencing via the I²C/SMBus interface.

6.13 Fault Spreading

Digital DC devices can be configured to broadcast a fault event over the DDC bus to the other devices in the group. When a non-destructive fault occurs and the device is configured to shut down on a fault, the device will shut down and broadcast the fault event over the DDC bus. The other devices on the DDC bus will shut down together if configured to do so, and will attempt to re-start in their prescribed order if configured to do so.

6.14 Temperature Monitoring Using the XTEMP Pin

The ZL2006 supports measurement of an external device temperature using either a thermal diode integrated in a processor, FPGA or ASIC, or using a discrete diode-connected 2N3904 NPN transistor. Figure 22 illustrates the typical connections required.

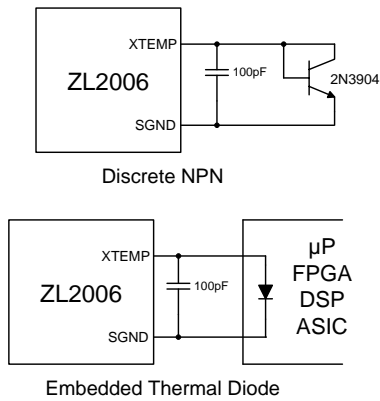

Figure 22. External Temperature Monitoring

6.15 Active Current Sharing

Paralleling multiple ZL2006 devices can be used to increase the output current capability of a single power rail. By connecting the DDC pins of each device together and configuring the devices as a current sharing rail, the units will share the current equally within a few percent.

Figure 23 illustrates a typical connection for three devices.

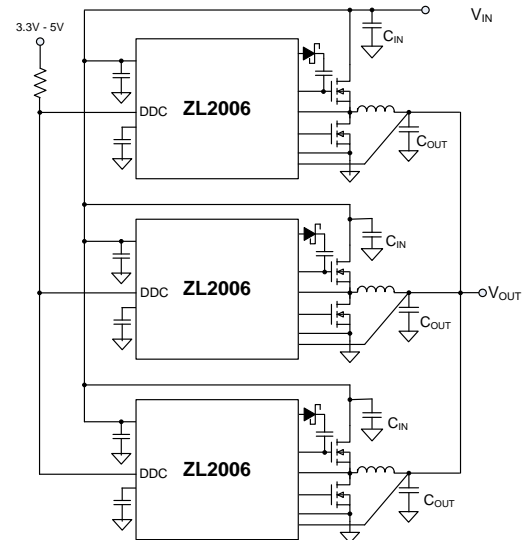

Figure 23. Current Sharing Group

The ZL2006 uses a low-bandwidth digital current sharing technique to balance the unequal device output loading by aligning the load lines of member devices to a reference device.

Table 29. CFG Pin Configurations for Sequencing

R _{CFG}	SYNC Pin Config	Sequencing Configuration
10 kΩ	Input	Sequencing is disabled
11 kΩ	Auto detect	
12.1 kΩ	Output	
14.7 kΩ	Input	The ZL2006 is configured as the first device in a nested sequencing group. Turn on order is based on the device SMBus address.
16.2 kΩ	Auto detect	
17.8 kΩ	Output	
21.5 kΩ	Input	The ZL2006 is configured as a last device in a nested sequencing group. Turn on order is based on the device SMBus address.
23.7 kΩ	Auto detect	
26.1 kΩ	Output	
31.6 kΩ	Input	The ZL2006 is configured as the middle device in a nested sequencing group. Turn on order is based on the device SMBus address.
34.8 kΩ	Auto detect	
38.3 kΩ	Output	

Droop resistance is used to add artificial resistance in the output voltage path to control the slope of the load line curve, calibrating out the physical parasitic mismatches due to power train components and PCB layout.

Upon system start-up, the device with the lowest member position as selected in ISHARE_CONFIG is defined as the reference device. The remaining devices are members. The reference device broadcasts its current over the DDC bus. The members use the reference current information to trim their voltages (V_{MEMBER}) to balance the current loading of each device in the system.

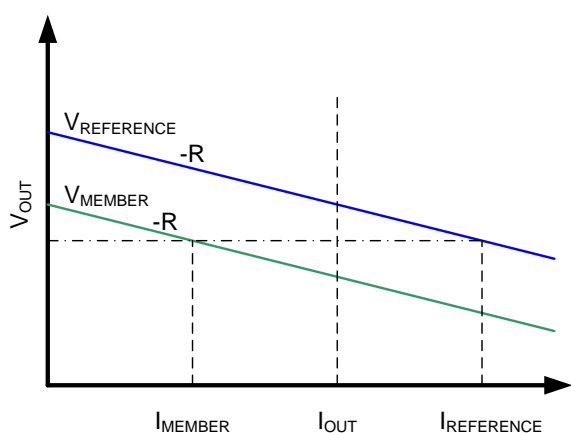

Figure 24. Active Current Sharing

Figure 24 shows that, for load lines with identical slopes, the member voltage is increased towards the reference voltage which closes the gap between the inductor currents.

The relation between reference and member current and voltage is given by the following equation:

$$V_{MEMBER} = V_{OUT} + R \times (I_{REFERENCE} - I_{MEMBER})$$

where R is the value of the droop resistance.

The ISHARE_CONFIG command is used to configure the device for active current sharing. The default setting is a stand-alone non-current sharing device. A current sharing rail can be part of a system sequencing group.

For fault configuration, the current share rail is configured in a quasi-redundant mode. In this mode, when a member device fails, the remaining members will continue to operate and attempt to maintain regulation. Of the remaining devices, the device with the lowest member position will become the reference. If fault spreading is enabled, the current share rail

failure is not broadcast until the entire current share rail fails.

Up to eight (8) devices can be configured in a given current sharing rail.

6.16 Phase Adding/Dropping

The ZL2006 allows multiple power converters to be connected in parallel to supply higher load currents than can be addressed using a single-phase design. In doing so, the power converter is optimized at a load current range that requires all phases to be operational. During periods of light loading, it may be beneficial to disable one or more phases in order to eliminate the current drain and switching losses associated with those phases, resulting in higher efficiency.

The ZL2006 offers the ability to add and drop phases using a simple command in response to an observed load current change, enabling the system to continuously optimize overall efficiency across a wide load range. All phases in a current share rail are considered active prior to the current sharing rail ramp to power-good.

Phases can be dropped after power-good is reached. Any member of the current sharing rail can be dropped. If the reference device is dropped, the remaining active device with the lowest member position will become the new reference.

Additionally, any change to the number of members of a current sharing rail will precipitate autonomous phase distribution within the rail where all active phases realign their phase position based on their order within the number of active members.

If the members of a current sharing rail are forced to shut down due to an observed fault, all members of the rail will attempt to re-start simultaneously after the fault has cleared.

6.17 Monitoring via I²C/SMBus

A system controller can monitor a wide variety of different ZL2006 system parameters through the I²C/SMBus interface. The device can monitor for fault conditions by monitoring the SALRT pin, which will be pulled low when any number of pre-configured fault conditions occur.

The device can also be monitored continuously for any number of power conversion parameters including but not limited to the following:

- Input voltage / Output voltage
- Output current
- Internal junction temperature
- Temperature of an external device
- Switching frequency
- Duty cycle

The PMBus Host should respond to SALRT as follows:

1. ZL device pulls SALRT Low
2. PMBus Host detects that SALRT is now low, performs transmission with Alert Response Address to find which ZL device is pulling SALRT low.
3. PMBus Host talks to the ZL device that has pulled SALRT low. The actions that the host performs are up to the System Designer.

If multiple devices are faulting, SALRT will still be low after doing the above steps and will require transmission with the Alert Response Address repeatedly until all faults are cleared.

Please refer to Application Note AN33 for details on how to monitor specific parameters via the I²C/SMBus interface.

6.18 Snapshot™ Parameter Capture

The ZL2006 offers a special mechanism that enables the user to capture parametric data during normal operation or following a fault. The Snapshot functionality is enabled by setting bit 1 of MISC_CONFIG to 1.

The Snapshot feature enables the user to read the parameters listed in Table 30 via a block read transfer through the SMBus. This can be done during normal operation, although it should be noted that reading the 22 bytes will occupy the SMBus for some time.

Table 30. Snapshot Parameters

Byte	Description	Format
31:22	Reserved	Linear
21:20	Vin	Linear
19:18	Vout	Vout Linear
17:16	Iout,avg	Linear
15:14	Iout,peak	Linear
13:12	Duty cycle	Linear
11:10	Internal temp	Linear
9:8	External temp	Linear
7:6	fsw	Linear
5	Vout status	Byte
4	Iout status	Byte
3	Input status	Byte
2	Temp status	Byte
1	CML status	Byte
0	Mfr specific status	Byte

The SNAPSHOT_CONTROL command enables the user to store the snapshot parameters to Flash memory in response to a pending fault as well as to read the stored data from Flash memory after a fault has occurred. Table 31 describes the usage of this command. Automatic writes to Flash memory following a fault are triggered when any fault threshold level is exceeded, provided that the specific fault's response is to shut down (writing to Flash memory is not allowed if the device is configured to re-try following the specific fault condition). It should also be noted that the device's V_{DD} voltage must be maintained during the time when the device is writing the data to Flash memory; a process that requires between 700-1400 μs depending on whether the data is set up for a block write. Undesirable results may be observed if the device's V_{DD} supply drops below 3.0 V during this process.

Table 31. SNAPSHOT_CONTROL Command

Data Value	Description
1	Copies current SNAPSHOT values from Flash memory to RAM for immediate access using SNAPSHOT command.
2	Writes current SNAPSHOT values to Flash memory. Only available when device is disabled.

In the event that the device experiences a fault and power is lost, the user can extract the last SNAPSHOT parameters stored during the fault by writing a 1 to SNAPSHOT_CONTROL (transfers data from Flash memory to RAM) and then issuing a SNAPSHOT command (reads data from RAM via SMBus).

6.19 Non-Volatile Memory and Device Security Features

The ZL2006 has internal non-volatile memory where user configurations are stored. Integrated security measures ensure that the user can only restore the device to a level that has been made available to them. Refer to Section 5.4 “Start-up Procedure”, for details on how the device loads stored values from internal memory during start-up.

During the initialization process, the ZL2006 checks for stored values contained in its internal non-volatile memory. The ZL2006 offers two internal memory storage units that are accessible by the user as follows:

1. *Default Store:* A power supply module manufacturer may want to protect the module from damage by preventing the user from being able to modify certain values that are related to the physical construction of the module. In this case, the module manufacturer would use the Default Store and would allow the user to restore the device to its default setting but would restrict the user from restoring the device to the factory settings.
2. *User Store:* The manufacturer of a piece of equipment may want to provide the ability to modify certain power supply settings while still protecting the equipment from modifying values that can lead to a system level fault. The equipment manufacturer would use the User Store to achieve this goal.

Please refer to Application Note AN33 for details on how to set specific security measures via the I²C/SMBus interface.

7. Package Dimensions

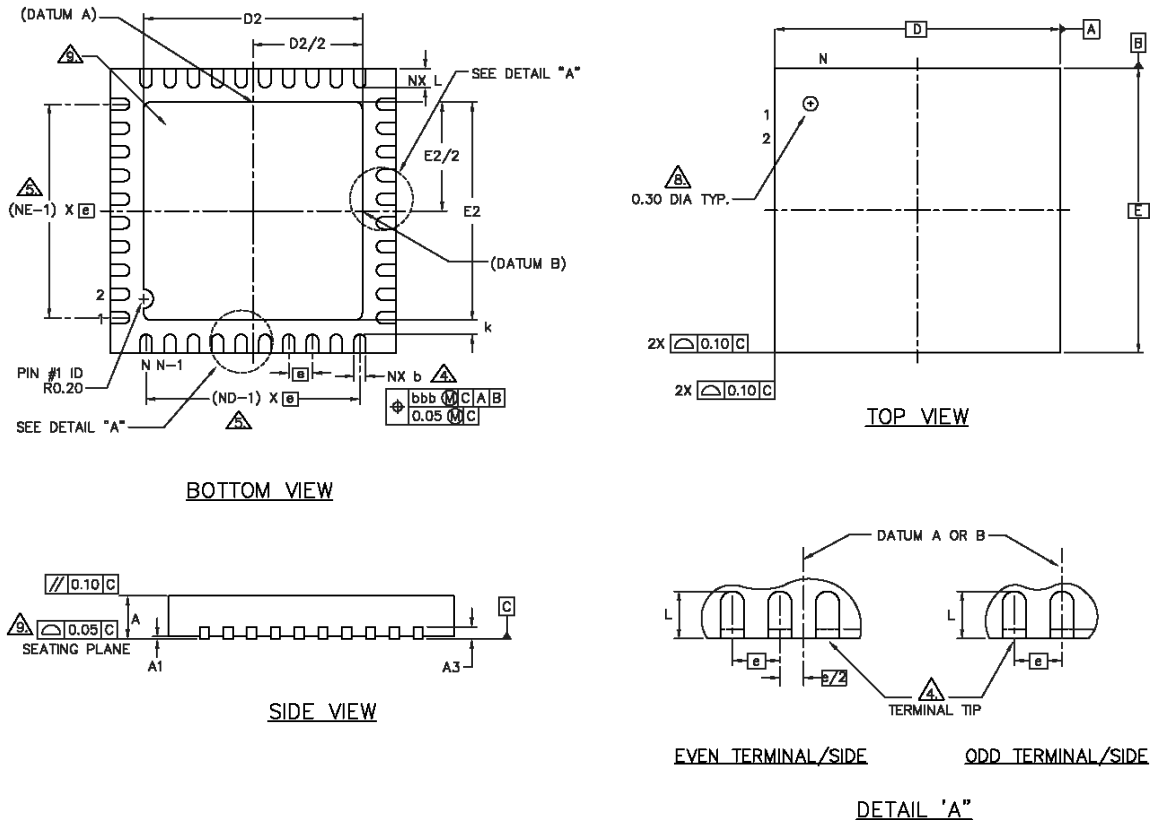

Notes:

1. Dimensions and tolerances conform to ASME Y14.5M - 1994.
2. All dimensions are in millimeters, θ is in degrees.
3. N is the total number of terminals.
4. Dimension b applies to metalized terminal and is measured between 0.15 and 0.33 mm from terminal tip. If the terminal has the optional radius on the other end of the terminal, the dimension b should not be measured in that radius area.
5. ND and NE refer to the number of terminals on each D and E side respectively.
6. Max package warpage is 0.05 mm.
7. Maximum allowable burrs is 0.076 mm in all directions.
8. Pin #1 ID on top will be laser marked.
9. Bilateral coplanarity zone applies to the exposed heat sink slug as well as the terminals.
10. This drawing conforms to JEDEC registered outline MO- 220.

S _{YM} B _{OL}	DIMENSIONS			N _{O_TE}
	MIN.	NOM.	MAX.	
A	0.80	0.85	0.90	
A1	0.00	0.02	0.05	
A3	0.20 REF			
θ	0	-	12	2
k	0.20 MIN			
D	6.0 BSC			
E	6.0 BSC			
[e]	0.50 BSC			
N	36			3
ND	9			5
NE	9			5
L	0.55	0.60	0.65	
b	0.18	0.25	0.30	4
D2	4.00	4.10	4.20	
E2	4.00	4.10	4.20	

8. Ordering Information

Z L 2 0 0 6 A L N F T

Product Designator

Shipping Option

T = Tape & Reel 100 pcs

T1 = Tape & Reel 1000 pcs

Contact factory for other options

Lead Finish

F = Lead-free Matte Tin

Firmware Revision

Alpha character

Ambient Temperature Range

L = -40 to +85°C

Package Designator

A = QFN package

9. Related Tools and Documentation

The following application support documents and tools are available to help simplify your design.

Item	Description
ZL2006EVK2	Evaluation Kit – ZL2006EV2, USB Adapter Board, GUI Software
AN33	Application Note: PMBus Command Set
AN34	Application Note: Current Sharing
AN35	Application Note: Digital-DC Control Loop Compensation

10. Revision History

Rev. #	Description	Date
1.0	Initial release.	March 2008
1.1	Soft start delay setting changed from 1 ms to 2 ms on Page 4. Soft start duration accuracy changed from -0/+4ms to -0.25/+4ms on Page 4. Clarified frequency selection on Page 20. Added detail to R1, R2 selection on Page 24. Corrected number of allowed violations in Table 19 on Page 25. Formatting changes on Page 26. Removed DDC address references in Sections 6.10, 6.12, and 6.15.	April 2008
1.2	Updated Ordering Information. Improved readability in current sharing description.	May 2008
1.3	Added comment that a device set up for tracking must have both Alternate Ramp Control and Precise Ramp-Up Delay disabled on Page 33. Clarified DDC pull-up requirement on Page 35.	June 2008
1.4	Corrected ILIM values in Table 22. Added note in Table 3 and Figure 17 that V_{OUT} must be less than 4.0 V for DCR current sensing. Corrected frequency values in Table 16. Updated Adaptive Frequency Control description on Page 30.	August 2008
1.5	Added V_{LIM} for DCR sensing to Table 22. Added equation for selecting V_{OUT} in Section 5.3. Added procedure for determining SA0, SA1 resistor values in Section 6.9.	
FN6850.0	Assigned file number FN6850 to datasheet as this will be the first release with an Intersil file number. Replaced header and footer with Intersil header and footer. Updated disclaimer information to read "Intersil and it's subsidiaries including Zilker Labs, Inc." No changes to datasheet content	February 2009
FN6850.1	Stamped "Not Recommended for New Designs Recommended Replacement Part ZL6100"	August 9, 2010
	Added footnote "Limits established by characterization and not production tested." to parameters throughout spec table	October 12, 2010
	Added following statement to disclaimer on page 45: "This product is subject to a license from Power One, Inc. related to digital power technology as set forth in U.S. Patent No. 7,000,125 and other related patents owned by Power One, Inc. These license rights do not extend to stand-alone POL regulators unless a royalty is paid to Power One, Inc." Removed note "Limits established by characterization and not production tested." from Electrical Specifications table and replaced with standard note in Min Max columns, "Compliance to datasheet limits is assured by one or more methods: production test, characterization and/or design."	November 30, 2010

Notes:

**© Copyright Intersil Americas LLC 2009-2010. All Rights Reserved.
All trademarks and registered trademarks are the property of their respective owners.**

For additional products, see www.intersil.com/product_tree
Intersil products are manufactured, assembled and tested utilizing ISO9001 quality systems as noted
in the quality certifications found at <http://www.intersil.com/en/support/qualandreliability.html>

Intersil products are sold by description only. Intersil may modify the circuit design and/or specifications of products at any time without notice, provided that such modification does not, in Intersil's sole judgment, affect the form, fit or function of the product. Accordingly, the reader is cautioned to verify that datasheets are current before placing orders. Information furnished by Intersil is believed to be accurate and reliable. However, no responsibility is assumed by Intersil or its subsidiaries for its use; nor for any infringements of patents or other rights of third parties which may result from its use. No license is granted by implication or otherwise under any patent or patent rights of Intersil or its subsidiaries.

This product is subject to a license from Power One, Inc. related to digital power technology as set forth in U.S. Patent No. 7,000,125 and other related patents owned by Power One, Inc. These license rights do not extend to stand-alone POL regulators unless a royalty is paid to Power One, Inc.

For information regarding Intersil Corporation and its products, see <http://www.intersil.com>

Looking for pricing, stock, or lifecycle information?

Click below to explore more details on WIN SOURCE:

 [View ZL2006ALNFT1 on WIN SOURCE](#)

 [Intersil Information](#)

Optimize Your Supply Chain with WIN SOURCE Solutions

-  Global Sourcing Solution
-  Obsolete Management
-  Cost Control Management
-  Shortage Management
-  Alternative Solution
-  Excess Inventory Management