



# THE DATASHEET OF LMX2353TMX/NOPB



# LMX2353

*LMX2353 PLLatinum Fractional N Single 2.5 GHz Low Power Frequency  
Synthesizer*



Literature Number: SNAS047A

# LMX2353

## PLLatinum™ Fractional N Single 2.5 GHz Low Power Frequency Synthesizer

### General Description

The LMX2353 is a monolithic integrated fractional N frequency synthesizer, designed to be used in a local oscillator subsystem for a radio transceiver. It is fabricated using National's 0.5 $\mu$  ABiC V silicon BiCMOS process. The LMX2353 contains dual modulus prescalers along with modulo 15 or 16 fractional compensation circuitry in the N divider. A 16/17 or 32/33 prescale ratio can be selected for the LMX2353. Using a fractional N phase locked loop technique, the LMX2353 can generate very stable low noise control signals for UHF and VHF voltage controlled oscillators (VCOs).

The LMX2353 has a highly flexible 16 level programmable charge pump which supplies output current magnitudes from 100  $\mu$ A to 1.6 mA. Two uncommitted CMOS outputs can be used to provide external control signals, or configured to FastLock™ mode. Serial data is transferred into the LMX2353 via a three wire interface (Data, LE, Clock). Supply voltage can range from 2.7 V to 5.5 V. The LMX2353 features very low current consumption; typically 5.5 mA at 3.0V. The LMX2353 is available in a 16-pin TSSOP or a 16-pin CSP surface mount plastic package.

### Features

- 2.7 V – 5.5 V operation
- Low Current Consumption
  - $I_{CC} = 5.5$  mA typ at  $V_{CC} = 3.0$  V
- Programmable or Logical Power Down Mode
  - $I_{CC} = 5$   $\mu$ A typ at  $V_{CC} = 3.0$  V
- Modulo 15 or 16 fractional N divider
  - Supports ratios of 1, 2, 3, 4, 5, 8, 15, or 16
- Programmable charge pump current levels
  - 100  $\mu$ A to 1.6 mA in 100  $\mu$ A steps
- Digital Filtered Lock Detect

### Applications

- Portable wireless communications (PCS/PCN, cordless)
- Zero blind slot TDMA systems
- Cellular and Cordless telephone systems
- Spread spectrum communication systems (CDMA)
- Cable TV Tuners (CATV)

### Functional Block Diagram

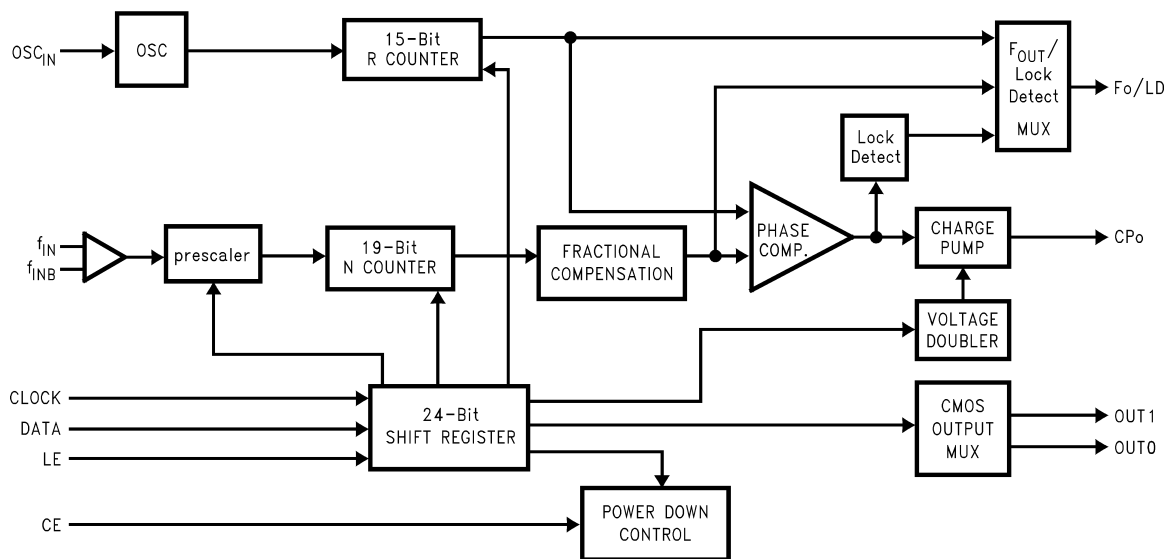

DS101124-1

## Connection Diagrams

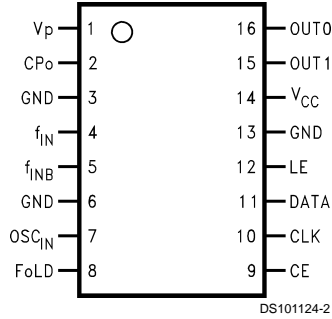

**TOP VIEW**  
**Order Number LMX2353TM or LMX2353TMX**  
**See NS Package Number MTC16**

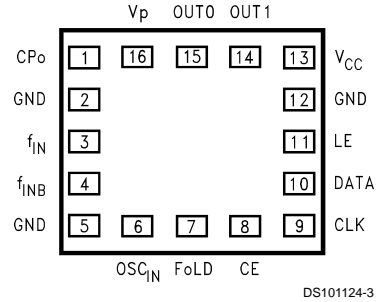

**TOP VIEW**  
**Order Number LMX2353SLBX**  
**See NS Package Number SLB16A**

## Pin Description

Pin No.		Pin Name	I/O	Description
CSP	TSSOP			
16	1	V <sub>P</sub>	—	Power supply for charge pump. Must be ≥ V <sub>CC</sub> .
1	2	CP <sub>O</sub>	O	Charge pump output. Connected to a loop filter for driving the control input of an external VCO.
2	3	GND	—	Ground for PLL digital circuitry.
3	4	f <sub>IN</sub>	I	RF prescaler input. Small signal input from the VCO.
4	5	f <sub>INB</sub>	I	RF prescaler complimentary input. A bypass capacitor should be placed as close as possible to this pin and be connected directly to the ground plane.
5	6	GND	—	Ground for PLL analog circuitry.
6	7	OSC <sub>IN</sub>	I	Oscillator input. A CMOS inverting gate input. The input has a V <sub>CC</sub> /2 input threshold and can be driven from an external CMOS or TTL logic gate.
7	8	F <sub>O</sub> LD	O	Multiplexed output of N or R divider and lock detect. CMOS output.
8	9	CE	I	PLL Enable. Powers down N and R counters, prescalers, and TRI-STATE® charge pump output when LOW. Bringing CE high powers up PLL depending on the state of CTL_WORD.
9	10	CLK	I	High impedance CMOS Clock input. Data for the various counters is clocked into the 24-bit shift register on the rising edge.
10	11	DATA	I	Binary serial data input. Data entered MSB first. The last two bits are the control bits. High impedance CMOS input.
11	12	LE	I	Load enable high impedance CMOS input. Data stored in the shift registers is loaded into one of the 4 internal latches when LE goes HIGH.
12	13	GND	—	Ground.
13	14	V <sub>CC</sub>	—	PLL power supply voltage input. May range from 2.7V to 5.5V. Bypass capacitors should be placed as close as possible to this pin and be connected directly to the ground plane.
14	15	OUT1	—	Programmable CMOS output. Level of the output is controlled by F2[18] bit.
15	16	OUT0	—	Programmable CMOS output. Level of the output is controlled by F2[17] bit.

**Absolute Maximum Ratings** (Notes 1, 2)

If Military/Aerospace specified devices are required, please contact the National Semiconductor Sales Office/Distributors for availability and specifications.

## Power Supply Voltage

$V_{CC}$	-0.3V to 6.5V
$V_p$	-0.3V to 6.5V

## Voltage on any pin with

GND = 0V ( $V_I$ )	-0.3V to $V_{CC}$ +0.3V
--------------------	-------------------------

Storage Temperature Range ( $T_S$ ) -65°C to +150°CLead Temperature (solder, 4 sec.) ( $T_L$ ) +260°C**Recommended Operating Conditions**

## Power Supply Voltage

$V_{CC}$	2.7 V to 5.5 V
$V_p$	$V_{CC}$ to 5.5 V

Operating Temperature ( $T_A$ ) -40°C to +85°C

**Note 1:** Absolute Maximum Ratings indicate limits beyond which damage to the device may occur. Operating Ratings indicate conditions for which the device is intended to be functional, but do not guarantee specific performance limits. For guaranteed specifications and test conditions, see the Electrical Characteristics. The guaranteed specifications apply only for the test conditions listed.

**Note 2:** This device is a high performance RF integrated circuit with an ESD rating < 2 kV and is ESD sensitive. Handling and assembly of this device should only be done at ESD free workstations.

**Electrical Characteristics** ( $V_{CC} = V_p = 3.0$  V;  $-40^\circ\text{C} < T_A < 85^\circ\text{C}$  except as specified).

All min/max specifications are guaranteed by design, or test, or statistical methods

Symbol	Parameter	Conditions	Value			Unit
			Min	Typ	Max	
<b>GENERAL</b>						
$I_{CC}$	Power Supply Current			5.5	6.75	mA
$I_{CC-PWDN}$	Power Down Current	CE = LOW		5	20	$\mu\text{A}$
$f_{IN}$	RF Operating Frequency	(Note 3)	0.5		2.5	GHz
$f_{OSC}$	Oscillator Frequency	(Note 3)	2		50	MHz
$f_\phi$	Phase Detector Frequency				10	MHz
$Pf_{IN}$	RF Input Sensitivity	$2.7\text{ V} \leq V_{CC} < 3.0\text{ V}$	-15		0	dBm
		$3.0\text{ V} \leq V_{CC} \leq 5.0\text{ V}$	-10		0	dBm
$V_{OSC}$	Oscillator Sensitivity	$OSC_{IN}$	0.5		$V_{CC}$	$V_{PP}$
<b>CHARGE PUMP</b>						
$ICP_{o-source}$	Charge Pump Output Current	$VCP_o = V_p/2$ , CP_WORD = 0000		-100		$\mu\text{A}$
$ICP_{o-sink}$		$VCP_o = V_p/2$ , CP_WORD = 0000		100		$\mu\text{A}$
$ICP_{o-source}$		$VCP_o = V_p/2$ , CP_WORD = 1111		-1.6		mA
$ICP_{o-sink}$		$VCP_o = V_p/2$ , CP_WORD = 1111		1.6		mA
$ICP_{o-TRI}$	Charge Pump TRI-STATE Current	$0.5 \leq VCP_o \leq V_p - 0.5$ , $-40^\circ\text{C} < T_A < 85^\circ\text{C}$	-2.5		2.5	nA
$ICP_{o-sink}$ vs $ICP_{o-source}$	CP Sink vs Source Mismatch	$VCP_o = V_p/2$ , $T_A = 25^\circ\text{C}$		3	10	%
$ICP_o$ vs $VCP_o$	CP Current vs Voltage	$0.5 \leq VCP_o \leq V_p - 0.5$ , $T_A = 25^\circ\text{C}$		4	15	%
$ICP_o$ vs T	CP Current vs Temperature	$VCP_o = V_p/2$ , $-40^\circ\text{C} < T_A < 85^\circ\text{C}$		8		%
<b>DIGITAL INTERFACE (DATA, CLK, LE, CE, F<sub>o</sub>LD)</b>						
$V_{IH}$	High-Level Input Voltage	(Note 4)	0.8 $V_{CC}$			V
$V_{IL}$	Low-Level Input Voltage	(Note 4)			0.2 $V_{CC}$	V
$I_{IH}$	High-Level Input Current	$V_{IH} = V_{CC} = 5.5\text{V}$ , (Note 4)	-1.0		1.0	$\mu\text{A}$
$I_{IL}$	Low-Level Input Current	$V_{IL} = 0$ , $V_{CC} = 5.5\text{V}$ , (Note 4)	-1.0		1.0	$\mu\text{A}$
$I_{IH}$	Oscillator Input Current	$V_{IH} = V_{CC} = 5.5\text{V}$			100	$\mu\text{A}$
$I_{IL}$	Oscillator Input Current	$V_{IL} = 0$ , $V_{CC} = 5.5\text{V}$	-100			$\mu\text{A}$
$V_{OH}$	High-Level Output Voltage	$I_{OH} = -500\ \mu\text{A}$	$V_{CC} - 0.4$			V
$V_{OL}$	Low-Level Output Voltage	$I_{OL} = 500\ \mu\text{A}$			0.4	V

**Electrical Characteristics** ( $V_{CC} = V_p = 3.0\text{ V}$ ;  $-40^\circ\text{C} < T_A < 85^\circ\text{C}$  except as specified).

All min/max specifications are guaranteed by design, or test, or statistical methods (Continued)

Symbol	Parameter	Conditions	Value			Unit
			Min	Typ	Max	
<b>MICROWIRE TIMING</b>						
$t_{CS}$	Data to Clock Setup Time	See Data Input Timing	50			ns
$t_{CH}$	Data to Clock Hold Time	See Data Input Timing	10			ns
$t_{CWH}$	Clock Pulse Width High	See Data Input Timing	50			ns
$t_{CWL}$	Clock Pulse Width Low	See Data Input Timing	50			ns
$t_{ES}$	Clock to Load Enable Setup Time	See Data Input Timing	50			ns
$t_{EW}$	Load Enable Pulse Width	See Data Input Timing	50			ns

**Note 3:** Minimum operating frequencies are not production tested—only characterized.**Note 4:** Except  $f_{IN}$  and  $OSC_{IN}$ .

# Charge Pump Current Specification Definitions

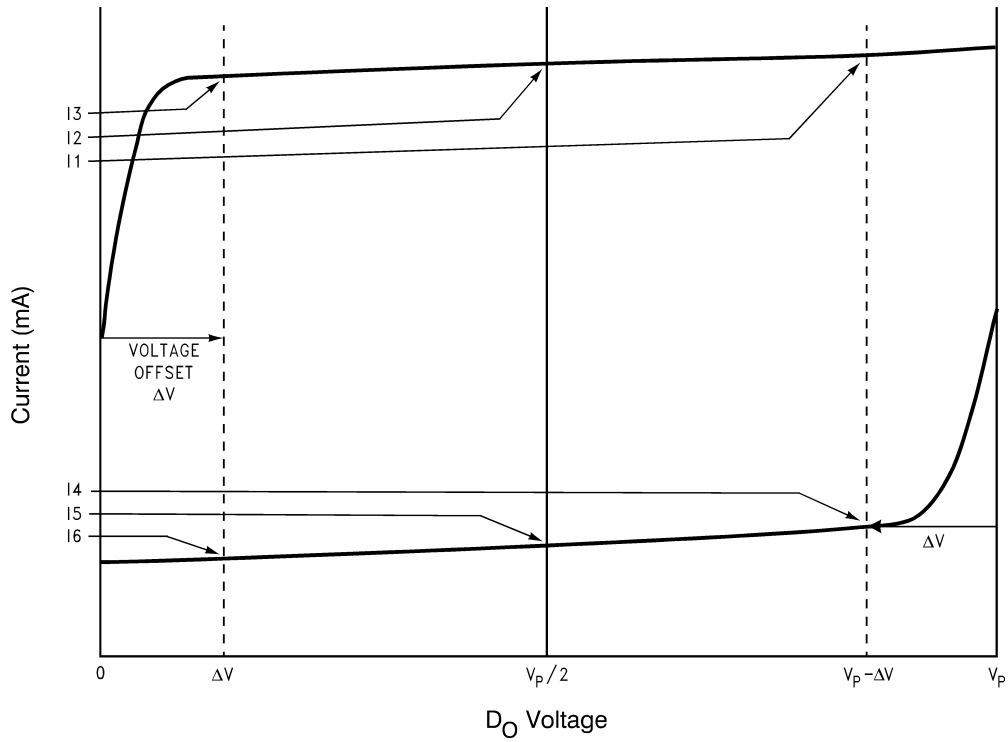

DS101124-9

I1 = CP sink current at  $V_{CP0} = V_P - \Delta V$

I2 = CP sink current at  $V_{CP0} = V_P/2$

I3 = CP sink current at  $V_{CP0} = \Delta V$

I4 = CP source current at  $V_{CP0} = V_P - \Delta V$

I5 = CP source current at  $V_{CP0} = V_P/2$

I6 = CP source current at  $V_{CP0} = \Delta V$

$\Delta V$  = Voltage offset from positive and negative rails. Dependent on VCO tuning range relative to V<sub>CC</sub> and ground. Typical values are between 0.5 V and 1.0 V.

**Note 5:**  $I_{CP0} \text{ vs } V_{CP0}$  = Charge Pump Output Current magnitude vs Variation Voltage =  
 $[1/2 * \{|I1| - |I3|\}] / [1/2 * \{|I1| + |I3|\}] * 100\%$  and  $[1/2 * \{|I4| - |I6|\}] / [1/2 * \{|I4| + |I6|\}] * 100\%$

**Note 6:**  $I_{CP0-SINK} \text{ vs } I_{CP0-SOURCE}$  = Charge Pump Output Current Sink vs Source Mismatch =  
 $[|I2| - |I5|] / [1/2 * \{|I2| + |I5|\}] * 100\%$

**Note 7:**  $I_{CP0} \text{ vs } T_A$  = Charge Pump Output Current magnitude variation vs Temperature =  
 $[|I2 @ temp| - |I2 @ 25^\circ C|] / |I2 @ 25^\circ C| * 100\%$  and  $[|I5 @ temp| - |I5 @ 25^\circ C|] / |I5 @ 25^\circ C| * 100\%$

# Typical Performance Characteristics

**I<sub>CC</sub> vs V<sub>CC</sub>**  
LMX2353

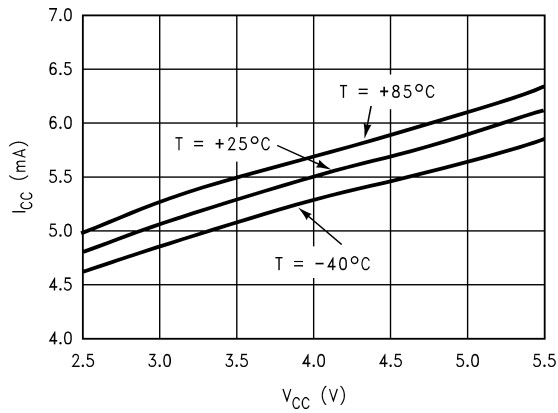

DS101124-10

**I<sub>CP0 TRI-STATE</sub> vs CP<sub>0</sub> Voltage**

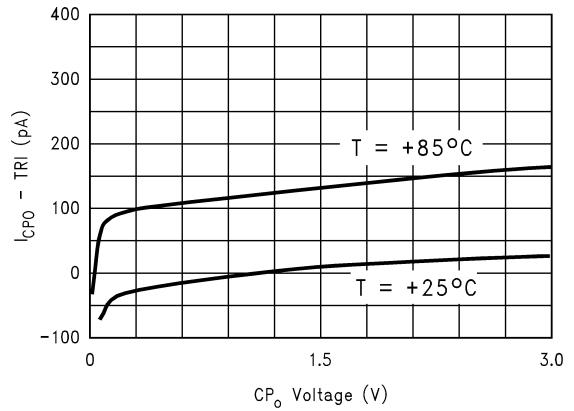

DS101124-11

**Charge Pump Current vs CP<sub>0</sub> Voltage**  
CP\_WORD = 0011 and 1111

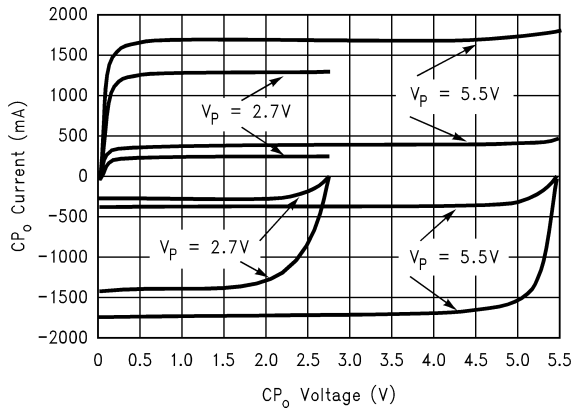

DS101124-12

**Sink vs Source Mismatch**  
(See (Note 6) under Charge Pump Current Specification Definitions)

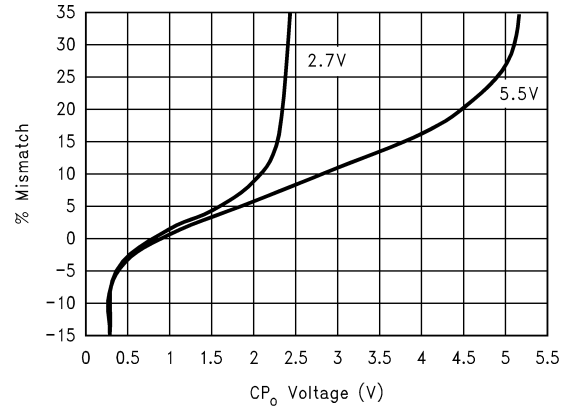

DS101124-13

**LMX2353 V<sub>P</sub> Voltage vs V<sub>P</sub> Load Current in V Doubler Mode, T = 25°C**

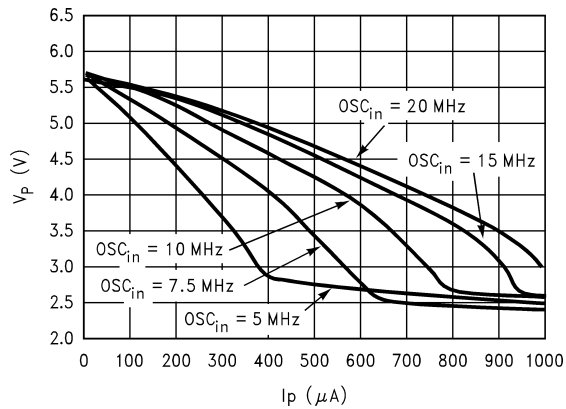

DS101124-17

# Typical Performance Characteristics (Continued)

**LMX2353 Sensitivity vs Frequency**

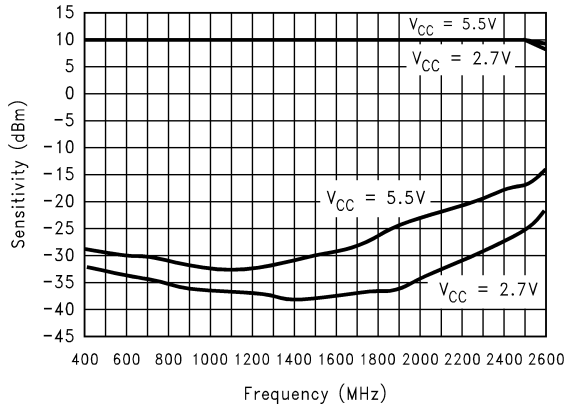

**Oscillator Input Sensitivity vs Frequency**

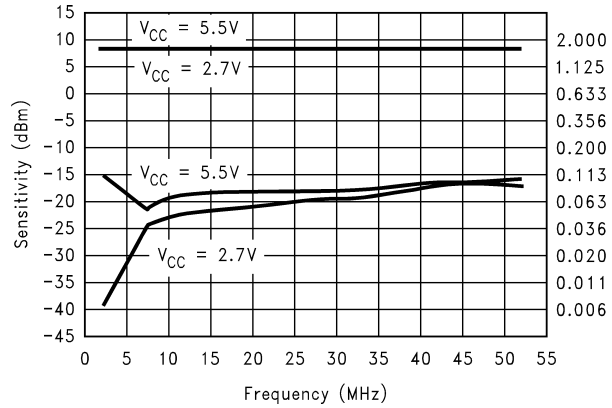

**RF Input Impedance**

V<sub>CC</sub> = 2.7 V to 5.5 V, f<sub>IN</sub> = 50 MHz to 3 GHz (f<sub>INB</sub> Capacitor = 100 pF)

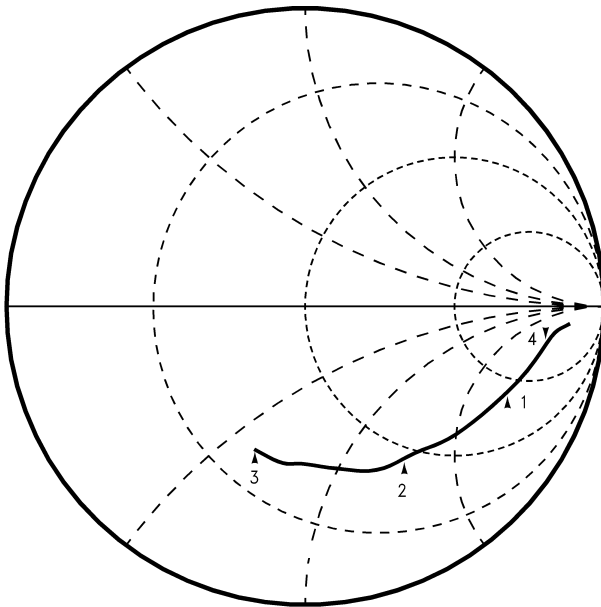

- Marker 1 = 1 GHz, Real = 130, Imaginary = -153
- Marker 2 = 2 GHz, Real = 44, Imaginary = -73
- Marker 3 = 3 GHz, Real = 25, Imaginary = -32
- Marker 4 = 500 MHz, Real = 246, Imaginary = -203

DS101124-14

## 1.0 Functional Description

The basic phase-locked-loop (PLL) configuration consists of a high-stability crystal reference oscillator, a frequency synthesizer such as the National Semiconductor LMX2353, a voltage controlled oscillator (VCO), and a passive loop filter. The frequency synthesizer includes a phase detector, current mode charge pump, as well as programmable reference [R] and feedback [N] frequency dividers. The VCO frequency is established by dividing the crystal reference signal down via the R counter to obtain a frequency that sets the comparison frequency. This reference signal, f<sub>r</sub>, is then presented to the input of a phase/frequency detector and compared with another signal, f<sub>p</sub>, the feedback signal, which was obtained by dividing the VCO frequency down by way of the N counter and fractional circuitry. The phase/frequency detector's current source outputs pump charge into the loop filter, which then converts the charge into the VCO's control voltage. The phase/frequency comparator's function is to adjust the voltage presented to the VCO until the feedback signal's frequency (and phase) match that of the reference signal. When this "phase-locked" condition exists, the RF VCO's frequency will be N+F times that of the comparison frequency, where N is the integer divide ratio and F is the fractional component. The fractional synthesis allows the phase detector frequency to be

## 1.0 Functional Description (Continued)

increased while maintaining the same frequency step size for channel selection. The division value N is thereby reduced giving a lower phase noise referred to the phase detector input, and the comparison frequency is increased allowing faster switching times.

### 1.1 REFERENCE OSCILLATOR INPUT

The reference oscillator frequency for the PLL is provided by an external reference TCXO through the OSC<sub>IN</sub> pin. OSC<sub>IN</sub> block can operate to 50 MHz with a minimum input sensitivity of 0.5 V<sub>pp</sub>. The inputs have a V<sub>CC</sub>/2 input threshold and can be driven from an external CMOS or TTL logic gate.

### 1.2 REFERENCE DIVIDER (R-COUNTER)

The R-counter is clocked through the oscillator block. The maximum frequency is 50 MHz. The R-counter is CMOS design and 15-bit in length with programmable divider ratio from 3 to 32,767.

### 1.3 FEEDBACK DIVIDER (N-COUNTER)

The N counter is clocked by the small signal f<sub>IN</sub> input pin. The N counter is 19 bits with 15 bits integer divide and 4 bits fractional. The integer part is configured as a 5-bit A counter and a 10-bit B counter. The LMX2353 is capable of operating from 500 MHz to 1.2 GHz with the 16/17 prescaler offering a continuous integer divide range from 272 to 16399, and 1.2 GHz to 2.5 GHz with the 32/33 prescaler offering a continuous integer divide range from 1056 to 32767. The fractional compensation is programmable in either 1/15 or 1/16 modes.

#### 1.3.1 Prescaler

The RF input to the prescaler consist of f<sub>IN</sub> and f<sub>INB</sub>; which are complimentary inputs to a differential pair amplifier. The complimentary input is internally coupled to ground with a 100 pF capacitor. This input is typically AC coupled to ground through external capacitors as well. A 16/17 or 32/33 prescaler ratio can be selected.

#### 1.3.2 Fractional Compensation

The fractional compensation circuitry in the N divider allows the user to adjust the VCO's tuning resolution in 1/16 or 1/15 increments of the phase detector comparison frequency. A 4-bit register is programmed with the fractions desired numerator, while another bit selects between fractional 15 and 16 modulo base denominator. An integer average is accomplished by using a 4-bit accumulator. A variable phase delay stage compensates for the accumulated integer phase error, minimizing the charge pump duty cycle, and reducing spurious levels. This technique eliminates the need for compensation current injection in to the loop filter. Overflow signals generated by the accumulator are equivalent to 1 full VCO cycle, and result in a pulse swallow.

### 1.4 PHASE/FREQUENCY DETECTOR

The phase/frequency detector is driven from the N and R counter outputs. The maximum frequency at the phase detector input is about 10 MHz for some high frequency VCO due to the minimum continuous divide ratio of the dual modulus prescaler. If the phase detector frequency exceeds 2.37 MHz, there are higher chances of running into illegal divide ratios, because the minimum continuous divide ratio with a 32/33 prescaler is 1056. The phase detector outputs control the charge pumps. The polarity of the pump-up or pump-down control is programmed using PD\_POL depending on whether the VCO characteristics are positive or negative. The phase detector also receives a feedback signal from the charge pump, in order to eliminate dead zone.

### 1.5 CHARGE PUMPS

The phase detector's current source output pumps charge into an external loop filter, which then integrates into the VCO's control voltage. The charge pump steers the charge pump output CP<sub>o</sub> to V<sub>CC</sub> (pump-up) or Ground (pump-down). When locked, CP<sub>o</sub> is primarily in a TRISTATE mode with small corrections. The charge pump output current magnitude can be selected from 100 μA to 1.6 mA by programming the CP\_WORD bits.

### 1.6 VOLTAGE DOUBLER

The V<sub>p</sub> pin is normally driven from an external power supply over a range of V<sub>CC</sub> to 5.5V to provide current for the RF charge pump circuit. An internal voltage doubler circuit connected between the V<sub>CC</sub> and V<sub>p</sub> supply pins alternately allows V<sub>CC</sub> = 3V (±10%) users to run the RF charge pump circuit at close to twice the V<sub>CC</sub> power supply voltage. The Voltage doubler mode is enabled by setting the V2\_EN bit (R[20]) to a HIGH level. The average delivery current of the doubler is less than the instantaneous current demand of the RF charge pump when active and is thus not capable of sustaining a continuous out of lock condition. A large external capacitor connected to V<sub>p</sub> (≈ 0.1 μF) is therefore needed to control power supply droop when changing frequencies.

### 1.7 MICROWIRE™ SERIAL INTERFACE

The programmable functions are accessed through the MICROWIRE serial interface. The interface is made of three functions: clock, data and latch enable (LE). Serial data for the various counters is clocked in from data on the rising edge of clock, into the 24-bit shift register. Data is entered MSB first. The last two bits decode the internal register address. On the rising edge of LE, data stored in the shift register is loaded into one of the 4 appropriate latches (selected by address bits). A complete programming description is included in the following sections.

## 1.0 Functional Description (Continued)

### 1.8 F<sub>o</sub>LD Multifunction Output

The F<sub>o</sub>LD output pin can deliver several internal functions including analog/digital lock detects, and counter outputs. See programming description 2.4.2 for more details.

#### 1.8.1 Lock Detect Output

A digital filtered lock detect function is included with each phase detector through an internal digital filter to produce a logic level output available on the F<sub>o</sub>LD output pin if selected. The lock detect output is high when the error between the phase detector inputs is less than 15 ns for 5 consecutive comparison cycles. The lock detect output is low when the error between the phase detector inputs is more than 30 ns for one comparison cycle. An analog lock detect status generated from the phase detector is also available on the F<sub>o</sub>LD output pin, if selected. The lock detect output goes high when the charge pump is inactive. It goes low when the charge pump is active during a comparison cycle. When a PLL is in power down mode, the respective lock detect output is always low. See programming descriptions 2.4.2.2 - 2.4.2.4.

### 1.9 OUT0/OUT1 Output Modes (FastLock & CMOS Output Modes)

The OUT\_0 and OUT\_1 pins are normally used as general purpose CMOS outputs or as part of a FastLock scheme. There is also a production test mode that overrides the other two normal modes when activated. The selection of these modes is determined by the 4 bit CMOS register (F2\_15–18) described in Table 2.5.3.

The FastLock mode allows the user to open up the loop bandwidth momentarily while acquiring lock by increasing the charge pump output current magnitude while simultaneously switching in a second resistor element to ground via the OUT0 output pin. The loop will lock faster without any additional stability considerations as the phase margin remains constant.

The loop bandwidth during FastLock can be opened up by as much as a factor of 4. The amount of bandwidth increase is a function of the square root of the charge pump current increase. The maximum charge pump current ratio results from switching the charge pump current between 100  $\mu$ A and 1.6 mA. The damping resistor ratio for these two charge pump current setting changes by the reciprocal of the bandwidth change. In the 4 to 1 bandwidth scenario, the resulting damping resistor value would be 1/4th of the steady state value. This would be achieved by switching 3 more identical resistors in parallel with the first to ground through the OUT\_0 pin.

### 1.10 POWER CONTROL

The PLL is power controlled by the device enable pin (CE) or MICROWIRE power down bit. The enable pin overrides the power down bit **except for the V2\_EN bit**. When CE is high, the power down bit determines the state of power control. Activation of any PLL power down mode results in the disabling of the N counter and de-biasing of f<sub>IN</sub> input (to a high impedance state). The R counter functionality also becomes disabled when the power down bit is activated. The reference oscillator block powers down and the OSC<sub>IN</sub> pin reverts to a high impedance state when CE or power down bit's are asserted, **unless the V2\_EN bit (R[20]) is high**. Power down forces the charge pump and phase comparator logic to a TRISTATE condition. A power down counter reset function resets both N and R counters. Upon powering up the N counter resumes counting in "close" alignment with the R counter (The maximum error is one prescaler cycle). The MICROWIRE control register remains active and capable of loading and latching in data during all of the power down modes.

## 2.0 Programming Description

### 2.1 MICROWIRE INTERFACE

The LMX2353 register set can be accessed through the MICROWIRE interface. A 24-bit shift register is used as a temporary register to indirectly program the on-chip registers. The shift register consists of a 24-bit DATA[21:0] field and a 2-bit ADDRESS[1:0] field as shown below. The address field is used to decode the internal register address. Data is clocked into the shift register in the direction from MSB to LSB, when the CLK signal goes high. On the rising edge of Latch Enable (LE) signal, data stored in the shift register is loaded into the addressed latch.

MSB		LSB	
DATA [21:0]		ADDRESS [1:0]	
23	2	1	0

#### 2.1.1 Registers' Address Map

When Latch Enable (LE) is transitioned high, data is transferred from the 24-bit shift register into the appropriate latch depending on the state of the ADDRESS[1:0] bits. A multiplexing circuit decodes these address bits and writes the data field to the corresponding internal register.

ADDRESS[1:0] FIELD		REGISTER ADDRESSED
0	0	F1 Register
0	1	F2 Register
1	0	R Register
1	1	N Register

## 2.0 Programming Description

(Continued)

### 2.1.2 Registers' Truth Table

		SHIFT REGISTER BIT LOCATION																			Least Significant Bit				
		23	22	21	20	19	18	17	16	15	14	13	12	11	10	9	8	7	6	5	4	3	2	1	0
		Data Field														Address Field									
F1	0	FOLD[2:0]																			0			0	
	F1_21	F1_20	F1_19	F1_18	F1_17	F1_16	F1_15	F1_14	F1_13	F1_12	F1_11	F1_10	F1_9	F1_8	F1_7	F1_6	F1_5	F1_4	F1_3	F1_2	F1_1	F1_0			
F2	0	CMOS[3:0]																			0			1	
	F2_21	F2_20	F2_19	F2_18	F2_17	F2_16	F2_15	F2_14	F2_13	F2_12	F2_11	F2_10	F2_9	F2_8	F2_7	F2_6	F2_5	F2_4	F2_3	F2_2	F2_1	F2_0			
R	DLL MODE	V2 EN	CP_WORD[4:0]																			1			0
	R_21	R_20	R_19	R_18	R_17	R_16	R_15	R_14	R_13	R_12	R_11	R_10	R_9	R_8	R_7	R_6	R_5	R_4	R_3	R_2	R_1	R_0			
N	CTL_WORD[2:0]		NB_CNTR[9:0]																			1			1
	N_21	N_20	N_19	N_18	N_17	N_16	N_15	N_14	N_13	N_12	N_11	N_10	N_9	N_8	N_7	N_6	N_5	N_4	N_3	N_2	N_1	N_0			

These bits should be set to zero

These bits should be set to zero

R\_CNTR[14:0]

NA\_CNTR[4:0]

FRAC\_CNTR[3:0]

Note: 0 denotes setting the bit to zero.

## 2.0 Programming Description (Continued)

### 2.2 R REGISTER

If the ADDRESS[1:0] field is set to 1 0 data is transferred from the 24-bit shift register into the R register which sets the PLL' s 15-bit R-counter divide ratio when Latch Enable (LE) signal goes high. The divide ratio is put into the R\_CNTR[14:0] field and is described in section 2.2.1. The divider ratio must be  $\geq 3$ . The bits used to control the voltage doubler (V2\_EN), Delay Lock Loop, (DLL\_MODE), Charge Pump (CP\_WORD) are detailed in section 2.2.2 -2.2.4 below.

Most Significant Bit		SHIFT REGISTER BIT LOCATION																		Least Significant Bit				
23	22	21	20	19	18	17	16	15	14	13	12	11	10	9	8	7	6	5	4	3	2	1	0	
<i>Data Field</i>																						<i>Address Field</i>		
DLL_MODE	V2_EN	CP_WORD[4:0]						R_CNTR[14:0]															1	0
R_21	R_20	R_19	R_18	R_17	R_16	R_15	R_14	R_13	R_12	R_11	R_10	R_9	R_8	R_7	R_6	R_5	R_4	R_3	R_2	R_1	R_0			

#### 2.2.1 Reference Divide Ratio (R\_CNTR)

If the ADDRESS [1:0] field is set to 1 0 data is transferred MSB first from the 24-bit shift register into a latch which sets the 15-bit R Counter, R\_CNTR[14:0]. Serial data format is shown below.

Divide Ratio	R_CNTR[14:0]														
	R_14	R_13	R_12	R_11	R_10	R_9	R_8	R_7	R_6	R_5	R_4	R_3	R_2	R_1	R_0
3	0	0	0	0	0	0	0	0	0	0	0	0	0	1	1
4	0	0	0	0	0	0	0	0	0	0	0	0	1	0	0
•	•	•	•	•	•	•	•	•	•	•	•	•	•	•	•
32,767	1	1	1	1	1	1	1	1	1	1	1	1	1	1	1

**Note:** R-counter divide ratio must be from 3 to 32,767.

#### 2.2.2 V2\_EN (R\_20)

The V2\_EN bit when set high enables the voltage doubler for the charge pump supply.

Bit	Location	Function	0	1
V2_EN	R_20	Voltage Doubler Enable	Disable	Enabled

#### 2.2.3 DLL\_MODE (R\_21)

The DLL\_MODE bit should be set to 1 for normal usage.

Bit	Location	Function	0	1
DLL_MODE	R_21	Delay Line Loop Calibration Mode	Slow	Fast

#### 2.2.4 CP\_WORD (R\_15-R\_19)

R_19	R_18	R_17	R_16	R_15
CP_8X	CP_4X	CP_2X	CP_1X	PD_POL

##### 2.2.4.1 Charge Pump Output Truth Table

ICP <sub>O</sub> $\mu$ A (typ)	R_19	R_18	R_17	R_16
	CP_8X	CP_4X	CP_2X	CP_1X
100	0	0	0	0
200	0	0	0	1
300	0	0	1	0
400	0	0	1	1
-	-	-	-	-
900	1	0	0	0
-	-	-	-	-
1600	1	1	1	1

## 2.0 Programming Description (Continued)

### 2.2.4.2 Phase Detector Polarity (PD\_POL)

Depending upon VCO characteristics, the PD\_POL (R\_15) bit should be set accordingly:  
 When VCO characteristics are positive like (1), PD\_POL should be set HIGH;  
 When VCO characteristics are negative like (2), PD\_POL should be set LOW.

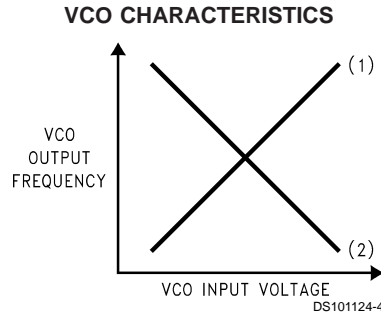

### 2.3 N REGISTER

If the ADDRESS[1:0] field is set to 1 1, data is transferred from the 24-bit shift register into the N register which sets the PLL's 19-bit N-counter, prescaler value, counter reset, and power-down bit. The 19-bit N counter consists of a 4-bit fractional numerator, FRAC\_CNTR[3:0], a 5-bit swallow counter, A\_CNTR[4:0], and a 10-bit programmable counter, B\_CNTR[9:0]. Serial data format is show below. The divide ratio (NB\_CNTR) must be  $\geq 3$ , and must be  $\geq$  swallow counter +2;  $NB\_CNTR \geq (NA\_CNTR + 2)$ .

Most Significant Bit		SHIFT REGISTER BIT LOCATION																		Least Significant Bit			
23	22	21	20	19	18	17	16	15	14	13	12	11	10	9	8	7	6	5	4	3	2	1	0
<i>Data Field</i>																						<i>Address Field</i>	
CTL_WORD[2:0]			NB_CNTR[9:0]										NA_CNTR[4:0]				FRAC_CNTR[3:0]			1	1		
N_21	N_20	N_19	N_18	N_17	N_16	N_15	N_14	N_13	N_12	N_11	N_10	N_9	N_8	N_7	N_6	N_5	N_4	N_3	N_2	N_1	N_0	1	1

#### 2.3.1 CTL\_WORD (N\_19-N\_21)

N_21	N_20	N_19
CNT_RST	PWDN	PRESC_SEL

#### 2.3.2 Control Word Truth Table

Bit	Location	Function	0	1
PRESC_SEL	N_19	Prescaler Modulus Select	16/17 (0.5 GHz to 1.2 GHz)	32/33 (1.2 GHz to 2.5 GHz)
PWDN	N_20	Power Down	Powered Up	Powered Down
CNT_RST	N_21	Counter Reset	Normal Operation	Reset
PWDN_MODE	F2_19	Power Down Mode Select	Asynchronous Power Down	Synchronous Power Down

##### 2.3.2.1 Counter Reset (CNT\_RST)

The Counter Reset enable bit when activated allows the reset of both N and R counters. Upon removal of the reset bit, the N counter resumes counting in "close" alignment with the R counter (the maximum error is one prescaler cycle).

##### 2.3.2.2 Power Down (PWDN)

Activation of the PLL PWDN bit results in the disabling of the N counter divider and de-biasing of the  $f_{IN}$  input (to a high impedance state). The R counter functionality also becomes disabled when the power down bit is activated. The OSC<sub>IN</sub> pin reverts to a high impedance state as well during power down. Power down forces the charge pump and phase comparator logic to a TRI-STATE condition. The MICROWIRE control register remains active and capable of loading and latching in data during all of the power down modes.

##### 2.3.2.3 Prescaler Modulus Select (PRESC\_SEL)

The PRESC\_SEL bit is used to set the RF prescaler modulus value. The LMX2353 is capable of operating from 500 MHz to 1.2 GHz with the 16/17 prescaler, and 1.2 GHz to 2.5 GHz with the 32/33 prescaler selection.

## 2.0 Programming Description (Continued)

### 2.3.2.4 Power Down Mode (PWDN\_MODE)

#### Synchronous Power Down Mode

The PLL loop can be synchronously powered down by setting the PWDN mode bit HIGH (F2\_19=1) and then asserting the power down mode bit (N20 = 1). The power down function is gated by the charge pump. Once the power down program bit is loaded, the part will go into power down mode upon the completion of a charge pump pulse event.

#### Asynchronous Power Down Mode

The PLL loop can be asynchronously powered down by setting the PWDN mode bit LOW (F2\_19=0) and then asserting the power down mode bit (N20 = 1). The power down function is NOT gated by the charge pump. Once the power down program bit is loaded, the part will go into power down mode immediately.

### 2.3.3 Feedback Divide Ratio (NB Counter)

Divide Ratio	NB_CNTR[9:0]									
	N_18	N_17	N_16	N_15	N_14	N_13	N_12	N_11	N_10	N_9
3	0	0	0	0	0	0	0	0	1	1
4	0	0	0	0	0	0	0	1	0	0
•	•	•	•	•	•	•	•	•	•	•
1023	1	1	1	1	1	1	1	1	1	1

**Note:** B-counter divide ratio must be  $\geq 3$ .  
NB\_CNTR  $\geq$  (NA\_CNTR +2).

### 2.3.4 Swallow Counter Divide Ratio (NA Counter)

Divide Ratio	NB_CNTR[4:0]				
	N_8	N_7	N_6	N_5	N_4
0	0	0	0	0	0
1	0	0	0	0	1
•	•	•	•	•	•
31	1	1	1	1	1

**Note:** Swallow Counter Value: 0 to 31.  
NB\_CNTR  $\geq$  (NA\_CNTR +2).

### 2.3.5 Fractional Modulus Accumulator (FRAC\_CNTR)

Divide Ratio	Divide Ratio	FRAC_CNTR[3:0]			
Modulus 15	Modulus 16	N_3	N_2	N_1	N_0
0	0	0	0	0	0
1/15	1/16	0	0	0	1
2/15	2/16	0	0	1	0
•	•	•	•	•	•
14/15	14/16	1	1	1	0
N/A	15/16	1	1	1	1

### 2.3.6 Pulse Swallow Function

$$f_{VCO} = [N+F] \times [f_{OSC}/R] \text{ where } N = (PxB) + A$$

$f_{VCO}$ : Output frequency of external voltage controlled oscillator (VCO)

F: Fractional ratio (contents of FRAC\_CNTR divided by the fractional modulus)

B: Preset divide ratio of binary 10-bit programmable counter (3 to 1023)

A: Preset divide ratio of binary 5-bit swallow counter

$$0 < A < 31 \text{ (P=32);}$$

$$0 < A < 15 \text{ (P=16);}$$

$$A + 2 < B$$

$f_{OSC}$ : Output frequency of the external reference frequency oscillator

## 2.0 Programming Description (Continued)

R: Preset divide ratio of binary 15-bit programmable reference counter (3 to 32767)

P: Preset modulus of dual modulus prescaler (P = 16 or 32)

### 2.4 F1 REGISTER

If the ADDRESS[1:0] field is set to 0 0, data is transferred from the 24-bit shift register into the F1 register when Latch Enable (LE) signal goes high. The F1 register sets the fractional divider denominator FRAC\_16 bit and F<sub>oLD</sub>/ Lock Detect output F<sub>oLD</sub> word. The rest of the bits F1\_0 - F1\_16, and F1\_21 are Don't Care.

Most Significant Bit				SHIFT REGISTER BIT LOCATION																Least Significant Bit			
23	22	21	20	19	18	17	16	15	14	13	12	11	10	9	8	7	6	5	4	3	2	1	0
Data Field																						Address Field	
0	FRAC_16	F <sub>oLD</sub>		These bits should be set to zero																		0	0
F1_21	F1_20	F1_19	F1_18	F1_17	F1_16	F1_15	F1_14	F1_13	F1_12	F1_11	F1_10	F1_9	F1_8	F1_7	F1_6	F1_5	F1_4	F1_3	F1_2	F1_1	F1_0		

Note: 0 denotes setting the bit to zero.

#### 2.4.1 FRAC\_16

The FRAC\_16 bit is used to set the fractional compensation at either 1/16 or 1/15 resolution. When FRAC\_16 bit is set to one, the fractional modulus is set to 1/16 resolution, and FRAC\_16 = 0 corresponds to 1/15. See section 2.3.5 for fractional divider values.

Bit	Location	Function	0	1
FRAC_16	F1_20	Fractional Modulus	1/15	1/16

#### 2.4.2 F<sub>oLD</sub>

The F<sub>oLD</sub> word is used to set the function of the Lock Detect output pin according to the Table 2.4.2.1 below. Open drain lock detect output is provided to indicate when the VCO frequency is in "lock". When the loop is locked and a lock detect mode is selected, the pin is HIGH, with narrow pulses LOW. See typical Lock detect timing in section 2.4.2.4.

##### 2.4.2.1 F<sub>oLD</sub> Programming Truth Table

F1_19	F1_18	F1_17	F <sub>oLD</sub> Output State
0	0	0	Analog Lock Detect (Open Drain)
0	0	1	Reserved
0	1	0	Digital Lock Detect
0	1	1	Reserved
1	0	0	Reserved
1	0	1	Reserved
1	1	0	N Divider Output
1	1	1	R Divider Output

Reserved - Denotes a disallowed programming condition.

##### 2.4.2.2 Lock Detect (LD) Digital Filter

The LD Digital Filter compares the difference between the phase of the inputs of the phase detector to a RC generated delay of approximately 15 ns. To enter the locked state (Lock = HIGH) the phase error must be less than the 15 ns RC delay for 5 consecutive reference cycles. Once in lock (Lock = HIGH), the RC delay is changed to approximately 30 ns. To exit the locked state (Lock = LOW), the phase error must become greater than the 30 ns RC delay. If the PLL is unlocked, the lock detect output will be forced LOW. A flow chart of the digital filter is shown next.

## 2.0 Programming Description (Continued)

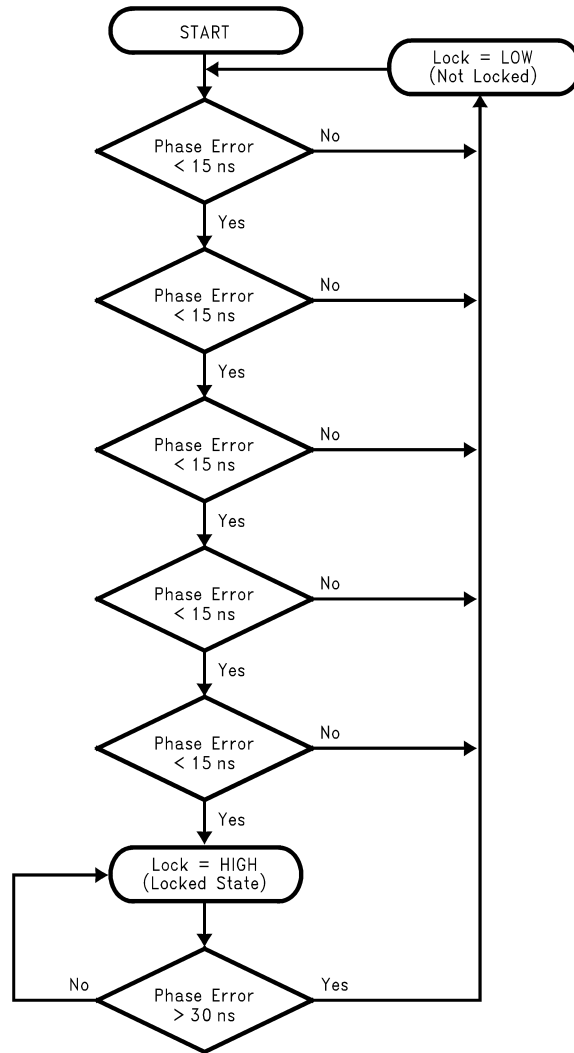

DS101124-5

### 2.4.2.3 Analog Lock Detect Filter

When the F<sub>OLD</sub> output is configured as analog lock detect output, an external lock detect circuit is needed in order to provide a steady LOW signal when the PLL is in the locked state. A typical circuit is shown below. It is noticed that F<sub>OLD</sub> is an “active low” open drain output.

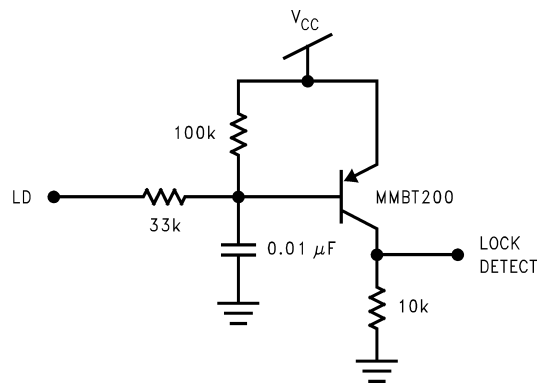

DS101124-6

## 2.0 Programming Description (Continued)

### 2.4.2.4 Typical Lock Detecting Timing

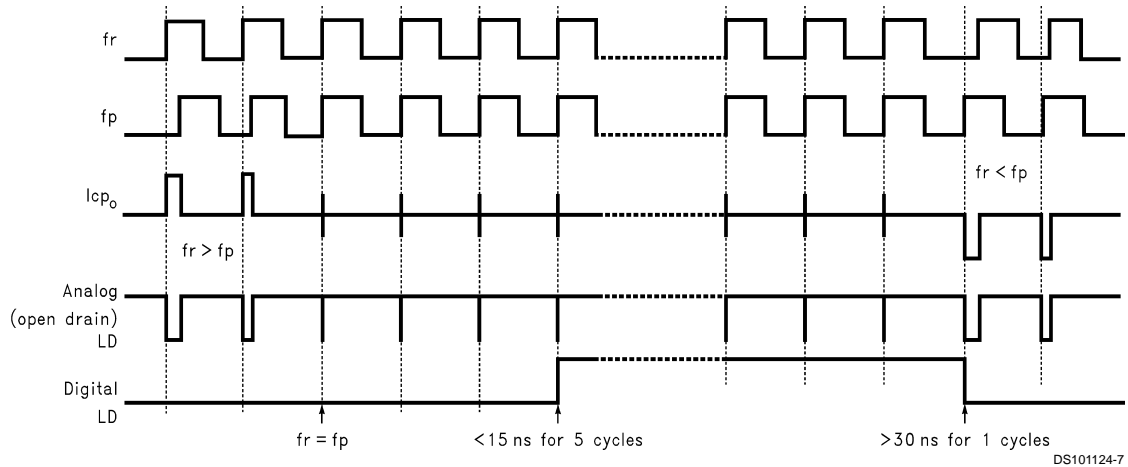

### 2.5 F2 REGISTER

If the ADDRESS[1:0] field is set to 0 1, data is transferred from the 24-bit shift register into the F2 register when Latch Enable (LE) signal goes high. The F2 register sets the CMOS output word bit CMOS[3:0] and the power down mode bit PWDN\_MODE. The rest of the bits F2\_0 - F2\_14, and F2\_20-F\_21 are Don't Care.

Most Significant Bit		SHIFT REGISTER BIT LOCATION																		Least Significant Bit				
23	22	21	20	19	18	17	16	15	14	13	12	11	10	9	8	7	6	5	4	3	2	1	0	
<i>Data Field</i>																						<i>Address Field</i>		
0	0	PWDN_MODE	CMOS[3:0]				These bits should be set to zero																0	0
F2_21	F2_20	F2_19	F2_18	F2_17	F2_16	F2_15	F2_14	F2_13	F2_12	F2_11	F2_10	F2_9	F2_8	F2_7	F2_6	F2_5	F2_4	F2_3	F2_2	F2_1	F2_0			

Note:0 denotes setting the bit to zero

#### 2.5.1 PWDN\_MODE (F2\_19)

See section 2.3.2 describing the control word and power down.

#### 2.5.2 Programmable CMOS Outputs (F2\_15–F2\_18)

F2_18	F2_17	F2_16	F2_15
FastLock	TEST	OUT_1	OUT_0

#### 2.5.3 OUT0/OUT1 Truth Table

Bit	Location	Function	0	1
OUT_0	F2_15	Set the output logic level of OUT0 pin	LOW	HIGH
OUT_1	F2_16	Set the output logic level of OUT1 pin	LOW	HIGH
TEST	F2_17	Test	Normal Operation	Test Mode
FastLock	F2_18	FastLock Mode	CMOS Output Mode	FastLock Mode

The CMOS[3:0] 4-bit register selects one of three modes for the OUT\_0 and OUT\_1 pins. The OUT\_0 and OUT\_1 pins are normally used as general purpose CMOS outputs or as part of a Fastlock™ scheme. There is also a production test mode that overrides the other two normal modes when activated.

GENERAL PURPOSE CMOS OUTPUT MODE: The general purpose CMOS output mode is selected when the Fastlock™ bit (F2\_F18) and TEST bit (F2\_17) are set LOW. The logic levels of the OUT\_0 bit (F2\_15) and OUT\_1 bit (F2\_16) then determine the logic states of the OUT\_0 and OUT\_1 pins.

Fastlock™ MODE: The Fastlock bit (F2\_18) selects between the general purpose CMOS output or Fastlock™ modes. The Fastlock™ mode is selected when the Fastlock™ bit is HIGH. The Fastlock™ mode allows the user to open up the loop bandwidth momentarily while acquiring lock by increasing the charge pump output current magnitude while simultaneously switching in a second resistor element to ground via the OUT0 output pin.

## 2.0 Programming Description (Continued)

The low gain or steadystate mode for fastlocking is defined to be whenever the charge pump current selected is less than 900  $\mu\text{A}$ . The high gain or acquisition mode is defined to be whenever the charge pump current is greater or equal to 900  $\mu\text{A}$ . (The logic setting of the CP\_8X bit determines which of the two gain modes the user is in.) During the acquisition phase when the CP\_8X bit is set to a HIGH state, the OUT0 output becomes active LOW thereby altering the loop's damping resistance.

The acquisition phase is terminated by setting the CP\_8X bit LOW resulting in the OUT0 output being OFF or TRI-STATE. When in fastlock mode, the OUT\_0 and OUT\_1 bits are don't care bits, and the OUT1 output is at TRI-STATE.

**TEST MODE:** The OUT0/OUT1 test mode occurs when the TEST bit (F2\_17) is set HIGH. This mode is intended for NSC production test only. Selecting this mode overrides the Fastlock™ and GEN PURPOSE modes.

### 2.5.4 Serial Data Input Timing

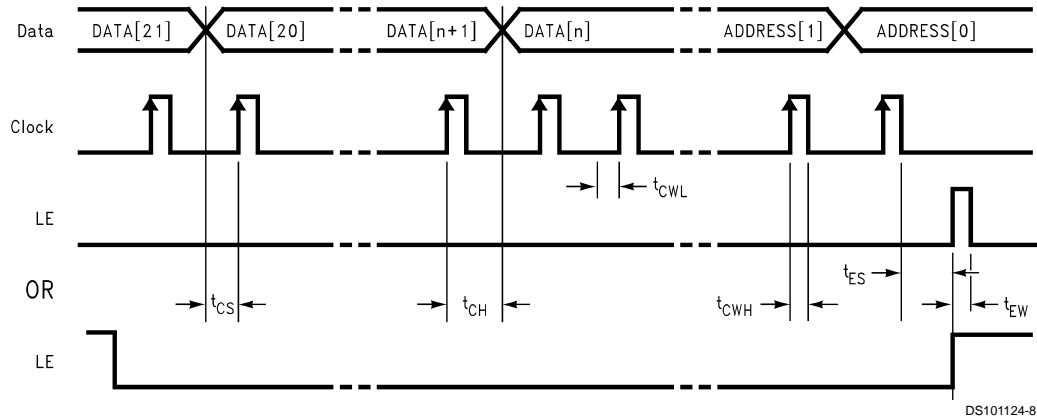

**Notes:** Data shifted into register on clock rising edge.

Data is shifted in MSB first.

**Test Conditions:** The Serial Data Input Timing is tested using a symmetrical waveform around  $V_{cc}/2$ . The test waveform has an edge rate of 0.6 V/ns with amplitudes of 2.2V @  $V_{cc} = 2.7\text{V}$  and 2.6V @  $V_{cc} = 5.5\text{V}$ .

DS101124-8

**Physical Dimensions** inches (millimeters) unless otherwise noted

DIMENSIONS METRIC ONLY

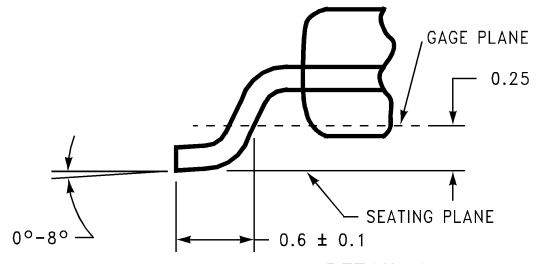
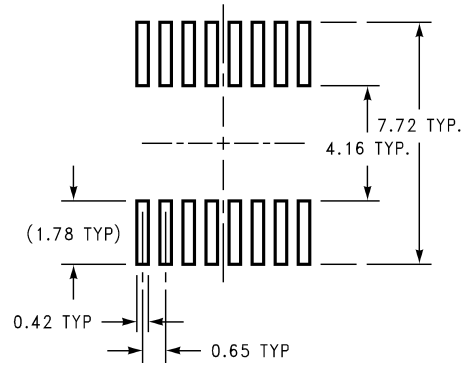
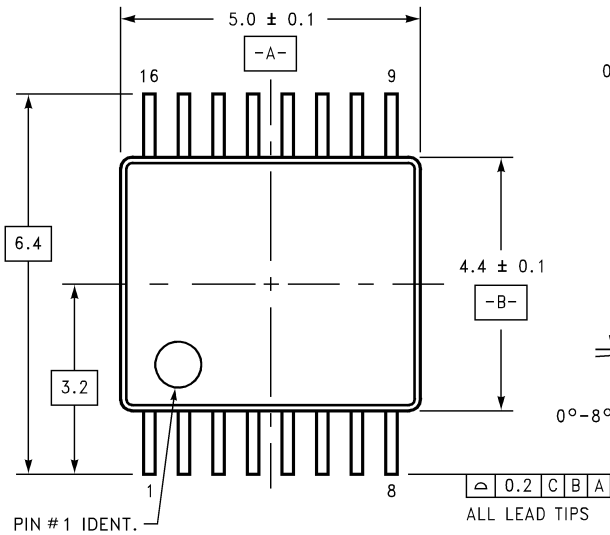

DETAIL A  
TYPICAL, SCALE: 40X

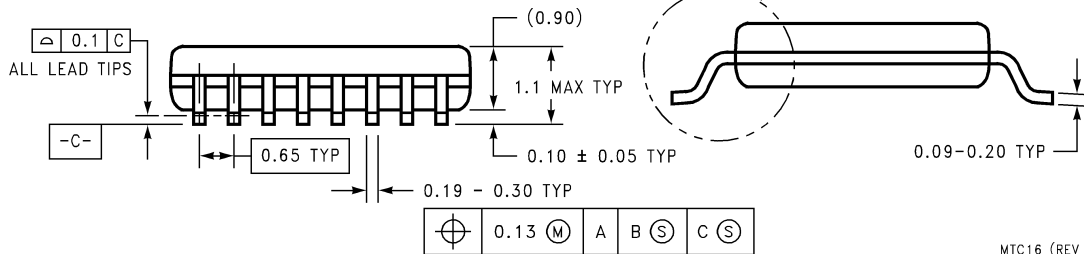

**TSSOP Package**  
**For Tube Quantity (94 Units Per Tube)**  
**For Tape and Reel (2500 Units Per Reel)**  
**Order Number LMX2353TM or LMX2353TMX**  
**NS Package Number MTC16**

**Physical Dimensions** inches (millimeters) unless otherwise noted (Continued)

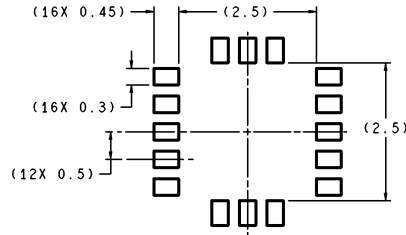

RECOMMENDED LAND PATTERN  
1:1 RATIO WITH PACKAGE SOLDER PADS

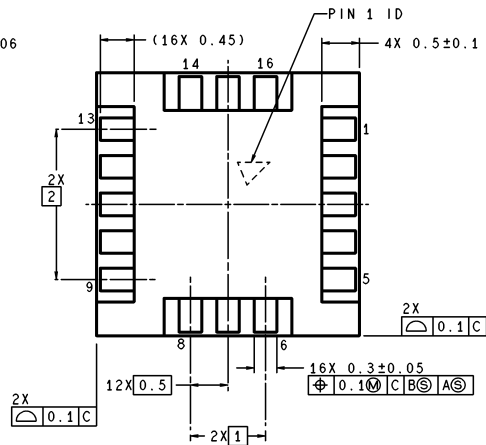
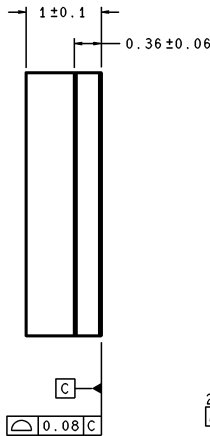
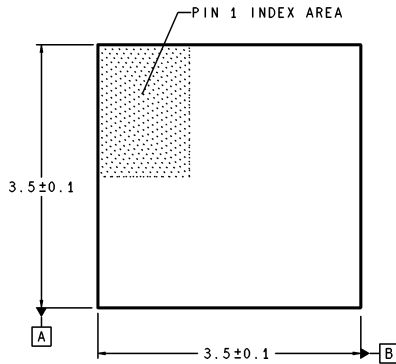

DIMENSIONS ARE IN MILLIMETERS

SLB16A (Rev B)

**Chip Scale Package**  
**For Tape and Reel (2500 Units Per Reel)**  
**Order Number: LMX2353SLBX**  
**NS Package Number SLB16A**

**LIFE SUPPORT POLICY**

NATIONAL'S PRODUCTS ARE NOT AUTHORIZED FOR USE AS CRITICAL COMPONENTS IN LIFE SUPPORT DEVICES OR SYSTEMS WITHOUT THE EXPRESS WRITTEN APPROVAL OF THE PRESIDENT AND GENERAL COUNSEL OF NATIONAL SEMICONDUCTOR CORPORATION. As used herein:

1. Life support devices or systems are devices or systems which, (a) are intended for surgical implant into the body, or (b) support or sustain life, and whose failure to perform when properly used in accordance with instructions for use provided in the labeling, can be reasonably expected to result in a significant injury to the user.
2. A critical component is any component of a life support device or system whose failure to perform can be reasonably expected to cause the failure of the life support device or system, or to affect its safety or effectiveness.

 **National Semiconductor Corporation**  
Americas  
Tel: 1-800-272-9959  
Fax: 1-800-737-7018  
Email: support@nsc.com  
www.national.com

**National Semiconductor Europe**  
Fax: +49 (0) 180-530 85 86  
Email: europe.support@nsc.com  
Deutsch Tel: +49 (0) 69 9508 6208  
English Tel: +44 (0) 870 24 0 2171  
Français Tel: +33 (0) 1 41 91 8790

**National Semiconductor Asia Pacific Customer Response Group**  
Tel: 65-2544466  
Fax: 65-2504466  
Email: ap.support@nsc.com

**National Semiconductor Japan Ltd.**  
Tel: 81-3-5639-7560  
Fax: 81-3-5639-7507

## IMPORTANT NOTICE

Texas Instruments Incorporated and its subsidiaries (TI) reserve the right to make corrections, modifications, enhancements, improvements, and other changes to its products and services at any time and to discontinue any product or service without notice. Customers should obtain the latest relevant information before placing orders and should verify that such information is current and complete. All products are sold subject to TI's terms and conditions of sale supplied at the time of order acknowledgment.

TI warrants performance of its hardware products to the specifications applicable at the time of sale in accordance with TI's standard warranty. Testing and other quality control techniques are used to the extent TI deems necessary to support this warranty. Except where mandated by government requirements, testing of all parameters of each product is not necessarily performed.

TI assumes no liability for applications assistance or customer product design. Customers are responsible for their products and applications using TI components. To minimize the risks associated with customer products and applications, customers should provide adequate design and operating safeguards.

TI does not warrant or represent that any license, either express or implied, is granted under any TI patent right, copyright, mask work right, or other TI intellectual property right relating to any combination, machine, or process in which TI products or services are used. Information published by TI regarding third-party products or services does not constitute a license from TI to use such products or services or a warranty or endorsement thereof. Use of such information may require a license from a third party under the patents or other intellectual property of the third party, or a license from TI under the patents or other intellectual property of TI.

Reproduction of TI information in TI data books or data sheets is permissible only if reproduction is without alteration and is accompanied by all associated warranties, conditions, limitations, and notices. Reproduction of this information with alteration is an unfair and deceptive business practice. TI is not responsible or liable for such altered documentation. Information of third parties may be subject to additional restrictions.

Resale of TI products or services with statements different from or beyond the parameters stated by TI for that product or service voids all express and any implied warranties for the associated TI product or service and is an unfair and deceptive business practice. TI is not responsible or liable for any such statements.

TI products are not authorized for use in safety-critical applications (such as life support) where a failure of the TI product would reasonably be expected to cause severe personal injury or death, unless officers of the parties have executed an agreement specifically governing such use. Buyers represent that they have all necessary expertise in the safety and regulatory ramifications of their applications, and acknowledge and agree that they are solely responsible for all legal, regulatory and safety-related requirements concerning their products and any use of TI products in such safety-critical applications, notwithstanding any applications-related information or support that may be provided by TI. Further, Buyers must fully indemnify TI and its representatives against any damages arising out of the use of TI products in such safety-critical applications.

TI products are neither designed nor intended for use in military/aerospace applications or environments unless the TI products are specifically designated by TI as military-grade or "enhanced plastic." Only products designated by TI as military-grade meet military specifications. Buyers acknowledge and agree that any such use of TI products which TI has not designated as military-grade is solely at the Buyer's risk, and that they are solely responsible for compliance with all legal and regulatory requirements in connection with such use.

TI products are neither designed nor intended for use in automotive applications or environments unless the specific TI products are designated by TI as compliant with ISO/TS 16949 requirements. Buyers acknowledge and agree that, if they use any non-designated products in automotive applications, TI will not be responsible for any failure to meet such requirements.

Following are URLs where you can obtain information on other Texas Instruments products and application solutions:

### Products

Audio	<a href="http://www.ti.com/audio">www.ti.com/audio</a>
Amplifiers	<a href="http://amplifier.ti.com">amplifier.ti.com</a>
Data Converters	<a href="http://dataconverter.ti.com">dataconverter.ti.com</a>
DLP® Products	<a href="http://www.dlp.com">www.dlp.com</a>
DSP	<a href="http://dsp.ti.com">dsp.ti.com</a>
Clocks and Timers	<a href="http://www.ti.com/clocks">www.ti.com/clocks</a>
Interface	<a href="http://interface.ti.com">interface.ti.com</a>
Logic	<a href="http://logic.ti.com">logic.ti.com</a>
Power Mgmt	<a href="http://power.ti.com">power.ti.com</a>
Microcontrollers	<a href="http://microcontroller.ti.com">microcontroller.ti.com</a>
RFID	<a href="http://www.ti-rfid.com">www.ti-rfid.com</a>
OMAP Mobile Processors	<a href="http://www.ti.com/omap">www.ti.com/omap</a>
Wireless Connectivity	<a href="http://www.ti.com/wirelessconnectivity">www.ti.com/wirelessconnectivity</a>

### Applications

Communications and Telecom	<a href="http://www.ti.com/communications">www.ti.com/communications</a>
Computers and Peripherals	<a href="http://www.ti.com/computers">www.ti.com/computers</a>
Consumer Electronics	<a href="http://www.ti.com/consumer-apps">www.ti.com/consumer-apps</a>
Energy and Lighting	<a href="http://www.ti.com/energy">www.ti.com/energy</a>
Industrial	<a href="http://www.ti.com/industrial">www.ti.com/industrial</a>
Medical	<a href="http://www.ti.com/medical">www.ti.com/medical</a>
Security	<a href="http://www.ti.com/security">www.ti.com/security</a>
Space, Avionics and Defense	<a href="http://www.ti.com/space-avionics-defense">www.ti.com/space-avionics-defense</a>
Transportation and Automotive	<a href="http://www.ti.com/automotive">www.ti.com/automotive</a>
Video and Imaging	<a href="http://www.ti.com/video">www.ti.com/video</a>

TI E2E Community Home Page

[e2e.ti.com](http://e2e.ti.com)

Mailing Address: Texas Instruments, Post Office Box 655303, Dallas, Texas 75265  
Copyright © 2011, Texas Instruments Incorporated







## Looking for pricing, stock, or lifecycle information?

Click below to explore more details on WIN SOURCE:

 [View LMX2353TMX/NOPB on WIN SOURCE](#)

 [Texas Instruments](#) Information

## Optimize Your Supply Chain with WIN SOURCE Solutions

-  Global Sourcing Solution
-  Obsolete Management
-  Cost Control Management
-  Shortage Management
-  Alternative Solution
-  Excess Inventory Management