



**THE DATASHEET OF  
TPS55330RTET**



## TPS55330 Integrated 5-A, 24-V Boost/SEPIC/Flyback DC-DC Regulator

### 1 Features

- Internal 5-A, 24-V Low-Side MOSFET Switch
- 2.9-V to 16-V Input Voltage Range
- $\pm 0.7\%$  Reference Voltage
- 0.5-mA Operating Quiescent Current
- 2.7- $\mu$ A Shutdown Supply Current
- Fixed-Frequency-Current-Mode PWM Control
- Frequency Adjustable From 100 kHz to 1.2 MHz
- Synchronization Capability to External Clock
- Adjustable Soft-Start Time
- Pulse-Skipping for Higher Efficiency at Light Loads
- Cycle-by-Cycle Current Limit, Thermal Shutdown, and UVLO Protection
- QFN-16 (3 mm  $\times$  3 mm) With PowerPAD™
- Wide  $-40^{\circ}\text{C}$  to  $+150^{\circ}\text{C}$  Operating  $T_J$  Range
- Create a Custom Design Using the TPS55330 With the [WEBENCH® Power Designer](#)

### 2 Applications

- 3.3-V, 5-V, 12-V Power Conversion
- Boost, SEPIC, and Flyback Topologies
- Thunderbolt Port, Power Docking for Tablets and Portable PCs
- Industrial Power Systems
- ADSL Modems

### 3 Description

The TPS55330 is a monolithic nonsynchronous switching regulator with integrated 5-A, 24-V power switch. The device can be configured in several standard switching-regulator topologies, including boost, SEPIC, and isolated flyback. The device has a wide input voltage range to support applications with input voltage from multicell batteries or regulated 3.3-V, 5-V, and 12-V power rails.

The TPS55330 regulates the output voltage with current mode PWM (pulse width modulation) control, and has an internal oscillator. The switching frequency of PWM is set by either an external resistor or by synchronizing to an external clock signal. The user can program the switching frequency from 100 kHz to 1.2 MHz.

The device features a programmable soft-start function to limit inrush current during start up and has other built-in protection features including cycle-by-cycle overcurrent limit and thermal shutdown.

The TPS55330 is available in a small 3-mm  $\times$  3-mm 16-pin QFN with PowerPAD for enhanced thermal performance.

#### Device Information<sup>(1)</sup>

PART NUMBER	PACKAGE	BODY SIZE (NOM)
TPS55330	WQFN (16)	3.00 mm $\times$ 3.00 mm

(1) For all available packages, see the orderable addendum at the end of the data sheet.

#### Typical Application (Boost)

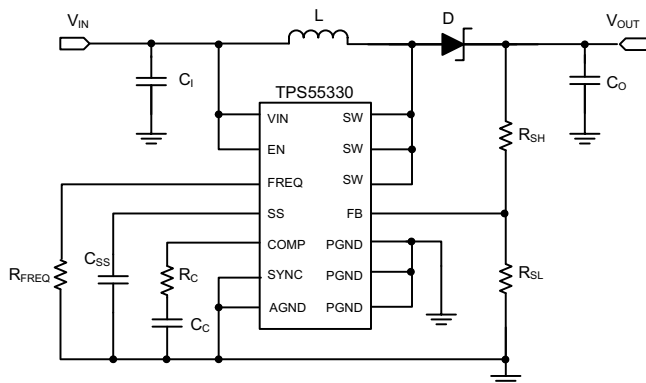

#### Efficiency vs Output Current

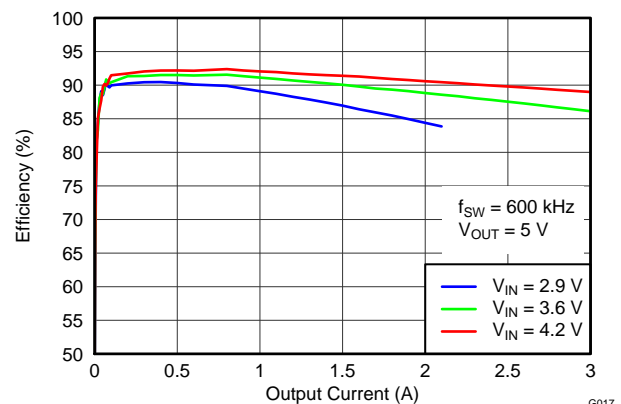

G017



## Table of Contents

<b>1 Features</b> .....	<b>1</b>	<b>8 Application and Implementation</b> .....	<b>13</b>
<b>2 Applications</b> .....	<b>1</b>	8.1 Application Information.....	13
<b>3 Description</b> .....	<b>1</b>	8.2 Typical Application .....	13
<b>4 Revision History</b> .....	<b>2</b>	<b>9 Power Supply Recommendations</b> .....	<b>22</b>
<b>5 Pin Configuration and Functions</b> .....	<b>3</b>	<b>10 Layout</b> .....	<b>22</b>
<b>6 Specifications</b> .....	<b>4</b>	10.1 Layout Guidelines .....	22
6.1 Absolute Maximum Ratings .....	4	10.2 Layout Example .....	22
6.2 ESD Ratings.....	4	10.3 Thermal Considerations .....	23
6.3 Recommended Operating Conditions.....	4	<b>11 Device and Documentation Support</b> .....	<b>24</b>
6.4 Thermal Information .....	4	11.1 Device Support.....	24
6.5 Electrical Characteristics.....	5	11.2 Receiving Notification of Documentation Updates	24
6.6 Typical Characteristics .....	6	11.3 Community Resources.....	24
<b>7 Detailed Description</b> .....	<b>9</b>	11.4 Trademarks .....	24
7.1 Overview .....	9	11.5 Electrostatic Discharge Caution.....	24
7.2 Functional Block Diagram .....	9	11.6 Glossary .....	25
7.3 Feature Description.....	9	<b>12 Mechanical, Packaging, and Orderable</b>	<b>Information</b> .....
7.4 Device Functional Modes.....	12		<b>25</b>

## 4 Revision History

NOTE: Page numbers for previous revisions may differ from page numbers in the current version.

<b>Changes from Revision A (October 2014) to Revision B</b>	<b>Page</b>
• Added links for Webench .....	1
• Added text note under pin configuration diagram.....	3

<b>Changes from Original (May 2013) to Revision A</b>	<b>Page</b>
• Added <i>Pin Configuration and Functions</i> section, <i>ESD Rating</i> table, <i>Feature Description</i> section, <i>Device Functional Modes</i> , <i>Application and Implementation</i> section, <i>Power Supply Recommendations</i> section, <i>Layout</i> section, <i>Device and Documentation Support</i> section, and <i>Mechanical, Packaging, and Orderable Information</i> section .....	1

## 5 Pin Configuration and Functions

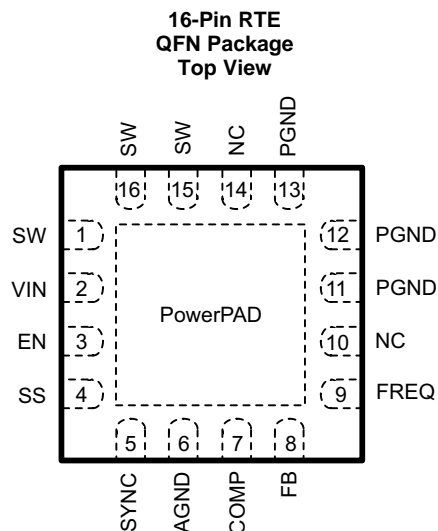

TI recommends connecting NC with AGND.

### Pin Functions

PIN		DESCRIPTION
NAME	NUMBER	
VIN	2	The input supply pin to the IC. Connect VIN to a supply voltage between 2.9 V and 16 V. It is acceptable for the voltage on the pin to be different from the boost power stage input.
SW	1, 15, 16	SW is the drain of the internal power MOSFET. Connect SW to the switched side of the boost or SEPIC inductor or the flyback transformer.
FB	8	Error amplifier input and feedback pin for positive voltage regulation. Connect to the center tap of a resistor divider to program the output voltage.
EN	3	Enable pin. When the voltage of this pin falls below the enable threshold for more than 1 ms, the IC turns off.
COMP	7	Output of the transconductance error amplifier. An external RC network connected to this pin compensates the regulator feedback loop.
SS	4	Soft-start programming pin. A capacitor between the SS pin and AGND pin programs soft-start timing.
FREQ	9	Switching frequency program pin. An external resistor connected between the FREQ pin and AGND sets the switching frequency.
AGND	6	Signal ground of the IC.
PGND	11, 12, 13	Power ground of the IC. It is connected to the source of the internal power MOSFET switch.
SYNC	5	Switching frequency synchronization pin. An external clock signal can be used to set the switching frequency between 200 kHz and 1 MHz. If not used, this pin should be tied to AGND.
NC	10, 14	Reserved pin that must be connected to ground.
PowerPAD	17	Solder the PowerPAD to the AGND. If possible, use thermal vias to connect to internal ground plane for improved power dissipation.

## 6 Specifications

### 6.1 Absolute Maximum Ratings<sup>(1)</sup>

over operating temperature range (unless otherwise noted)

	MIN	MAX	UNIT
Supply voltages on pin VIN <sup>(2)</sup>	−0.3	18	V
Voltage on pin EN <sup>(2)</sup>	−0.3	18	V
Voltage on pins FB, FREQ, and COMP <sup>(2)</sup>	−0.3	3	V
Voltage on pin SS <sup>(2)</sup>	−0.3	5	V
Voltage on pin SYNC <sup>(2)</sup>	−0.3	7	V
Voltage on pin SW <sup>(2)</sup>	−0.3	24	V
Operating junction temperature range	−40	150	°C
T <sub>stg</sub> Storage temperature range	−65	150	°C

- (1) Stresses beyond those listed under *Absolute Maximum Ratings* may cause permanent damage to the device. These are stress ratings only and functional operation of the device at these or any other conditions beyond those indicated under *Recommended Operating Conditions* is not implied. Exposure to absolute-maximum-rated conditions for extended periods may affect device reliability.
- (2) All voltage values are with respect to network ground pin

### 6.2 ESD Ratings

	VALUE	UNIT
V <sub>(ESD)</sub> Electrostatic discharge	Human-body model (HBM), per ANSI/ESDA/JEDEC JS-001 <sup>(1)</sup>	±2000
	Charged-device model (CDM), per JEDEC specification JESD22-C101 <sup>(2)</sup>	±500
		V

- (1) JEDEC document JEP155 states that 500-V HBM allows safe manufacturing with a standard ESD control process.
- (2) JEDEC document JEP157 states that 250-V CDM allows safe manufacturing with a standard ESD control process.

### 6.3 Recommended Operating Conditions

	MIN	MAX	UNIT
V <sub>IN</sub> Input voltage range	2.9	16	V
V <sub>OUT</sub> Output voltage range	V <sub>IN</sub>	22	V
V <sub>EN</sub> EN voltage range	0	16	V
V <sub>SYN</sub> External switching frequency logic input range	0	5	V
T <sub>A</sub> Operating free-air temperature	−40	125	°C
T <sub>J</sub> Operating junction temperature	−40	150	°C

### 6.4 Thermal Information

THERMAL METRIC <sup>(1)</sup>		TPS55330	UNIT
		QFN	
		16 PINS	
R <sub>θJA</sub>	Junction-to-ambient thermal resistance	43.3	°C/W
R <sub>θJC(top)</sub>	Junction-to-case (top) thermal resistance	38.7	
R <sub>θJB</sub>	Junction-to-board thermal resistance	14.5	
ψ <sub>JT</sub>	Junction-to-top characterization parameter	0.4	
ψ <sub>JB</sub>	Junction-to-board characterization parameter	14.5	
R <sub>θJC(bot)</sub>	Junction-to-case (bottom) thermal resistance	3.5	

- (1) For more information about traditional and new thermal metrics, see the *IC Package Thermal Metrics* application report, [SPRA953](http://SPRA953).

## 6.5 Electrical Characteristics

 $V_{IN} = 5\text{ V}$ ,  $T_J = -40^\circ\text{C}$  to  $+150^\circ\text{C}$ , unless otherwise noted. Typical values are at  $T_A = 25^\circ\text{C}$ .

PARAMETER		TEST CONDITIONS	MIN	TYP	MAX	UNIT
<b>SUPPLY CURRENT</b>						
$V_{IN}$	Input voltage range		2.9		16	V
$I_Q$	Operating quiescent current into $V_{IN}$	Device non-switching, $V_{FB} = 2\text{ V}$		0.5		mA
$I_{SD}$	Shutdown current	EN = GND		2.7	10	$\mu\text{A}$
$V_{UVLO}$	Under-voltage lockout threshold	$V_{IN}$ falling		2.5	2.7	V
$V_{hys}$	Under-voltage lockout hysteresis		120	140	160	mV
<b>ENABLE AND REFERENCE CONTROL</b>						
$V_{EN(r)}$	EN threshold voltage	EN rising input	0.9	1.08	1.30	V
$V_{EN(f)}$	EN threshold voltage	EN falling input	0.74	0.92	1.125	V
$V_{ENh}$	EN threshold hysteresis			0.16		V
$R_{EN}$	EN pulldown resistor		400	950	1600	k $\Omega$
$T_{off}$	Shutdown delay, SS discharge	EN high to low		1.0		ms
$V_{SYNh}$	SYN logic high voltage		1.2			
$V_{SYNl}$	SYN logic low voltage				0.4	V
<b>VOLTAGE AND CURRENT CONTROL</b>						
$V_{REF}$	Voltage feedback regulation voltage		1.204	1.229	1.254	V
		$T_A = 25^\circ\text{C}$	1.220	1.229	1.238	
$I_{FB}$	Voltage feedback input bias current	$T_A = 25^\circ\text{C}$		1.6	20	nA
$I_{sink}$	Comp pin sink current	$V_{FB} = V_{REF} + 200\text{ mV}$ , $V_{COMP} = 1\text{ V}$		42		$\mu\text{A}$
$I_{source}$	Comp pin source current	$V_{FB} = V_{REF} - 200\text{ mV}$ , $V_{COMP} = 1\text{ V}$		42		$\mu\text{A}$
$V_{CCLP}$	Comp pin Clamp Voltage	High Clamp, $V_{FB} = 1\text{ V}$		3.1		V
		Low Clamp, $V_{FB} = 1.5\text{ V}$		0.75		
$V_{CTH}$	Comp pin threshold	Duty cycle = 0%		1.04		V
$G_{ea}$	Error amplifier transconductance		240	360	440	$\mu\text{S}$
$R_{ea}$	Error amplifier output resistance			10		M $\Omega$
$f_{ea}$	Error amplifier crossover frequency			500		kHz
<b>FREQUENCY</b>						
$f_{SW}$	Frequency	$R_{FREQ} = 480\text{ k}\Omega$	75	94	130	kHz
		$R_{FREQ} = 80\text{ k}\Omega$	460	577	740	
		$R_{FREQ} = 40\text{ k}\Omega$	920	1140	1480	
$D_{max}$	Maximum duty cycle	$V_{FB} = 1.0\text{ V}$ , $R_{FREQ} = 80\text{ k}\Omega$	89%	96%		
$V_{FREQ}$	FREQ pin voltage			1.25		V
$T_{min\_on}$	Minimum on pulse width	$R_{FREQ} = 80\text{ k}\Omega$		77		ns
<b>POWER SWITCH</b>						
$R_{DS(ON)}$	N-channel MOSFET on-resistance	$V_{IN} = 5\text{ V}$		60	110	m $\Omega$
		$V_{IN} = 3\text{ V}$		70	120	
$I_{LN\_NFET}$	N-channel leakage current	$V_{DS} = 25\text{ V}$ , $T_A = 25^\circ\text{C}$			2.1	$\mu\text{A}$
<b>OCP and SS</b>						
$I_{LIM}$	N-Channel MOSFET current limit	$D = D_{max}$	5.25	6.6	7.75	A
$I_{SS}$	Soft-start bias current	$V_{SS} = 0\text{ V}$		6		$\mu\text{A}$
<b>THERMAL SHUTDOWN</b>						
$T_{shutdown}$	Thermal shutdown threshold			165		$^\circ\text{C}$
$T_{hysteresis}$	Thermal shutdown threshold hysteresis			15		$^\circ\text{C}$

## 6.6 Typical Characteristics

$V_{IN} = 5\text{ V}$ ,  $T_A = 25^\circ\text{C}$  (unless otherwise noted)

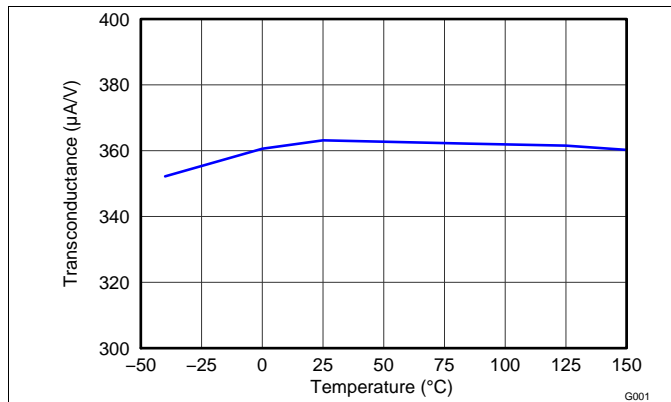

Figure 1. Error Amplifier Transconductance vs Temperature

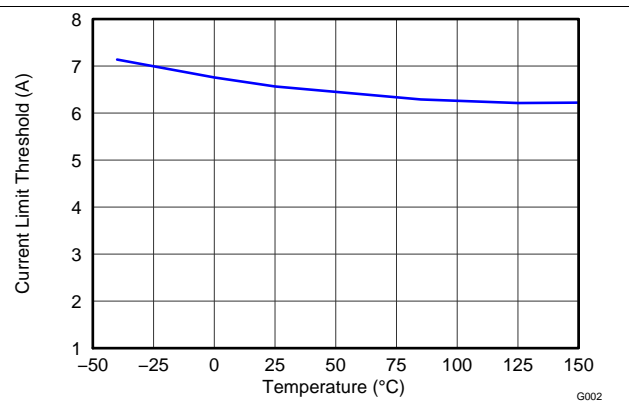

Figure 2. Switch Current Limit vs Temperature

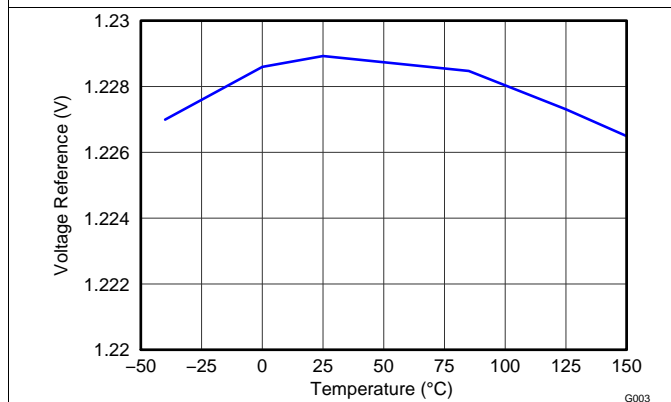

Figure 3. Feedback Voltage Reference vs Temperature

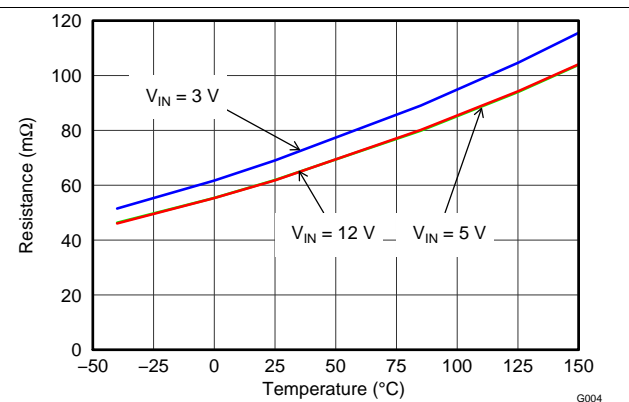

Figure 4.  $R_{DS(ON)}$  vs Temperature

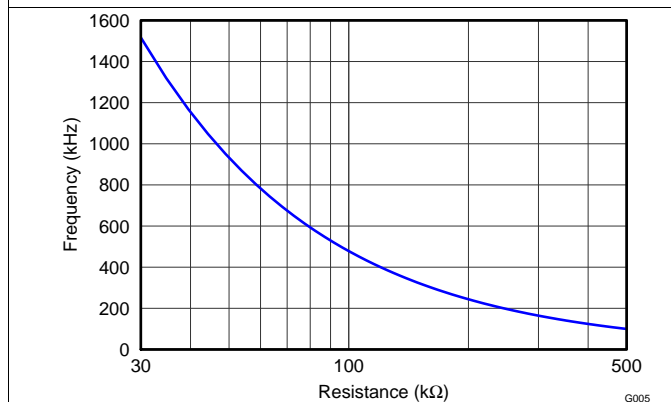

Figure 5. Frequency vs FREQ Resistance

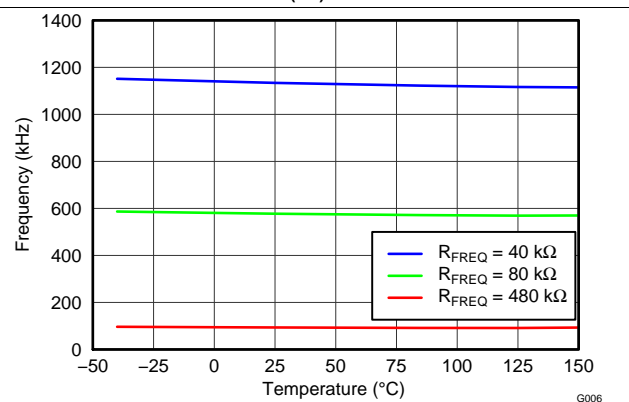

Figure 6. Frequency vs Temperature

Typical Characteristics (continued)

$V_{IN} = 5\text{ V}$ ,  $T_A = 25^\circ\text{C}$  (unless otherwise noted)

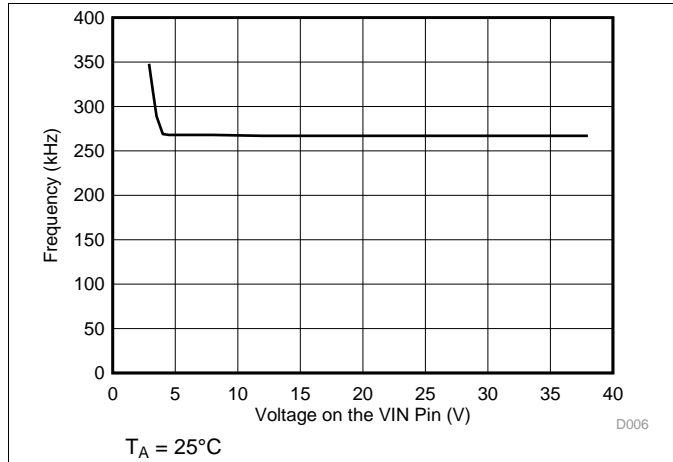

Figure 7. Minimum Switching Frequency for Quick Recovery from Frequency Foldback

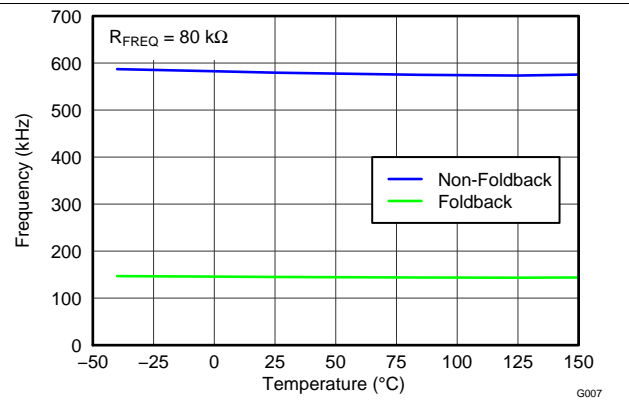

Figure 8. Non-Foldback Frequency vs Foldback Frequency

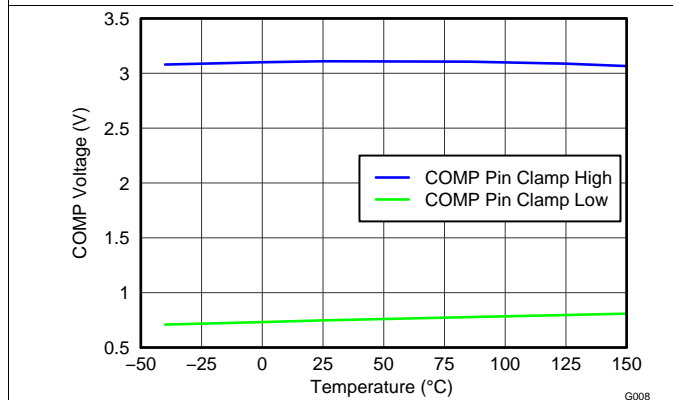

Figure 9. COMP Clamp Voltage vs Temperature

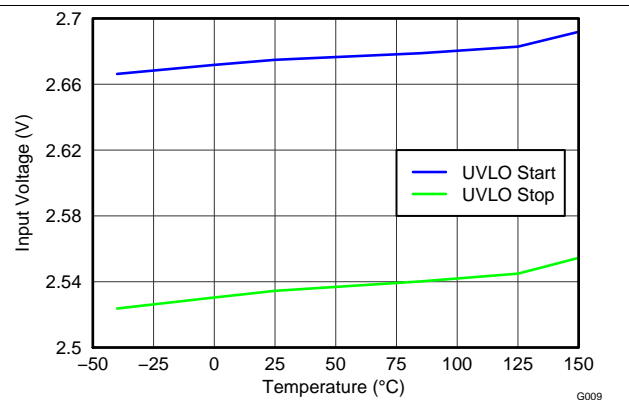

Figure 10. Input Voltage UVLO vs Temperature

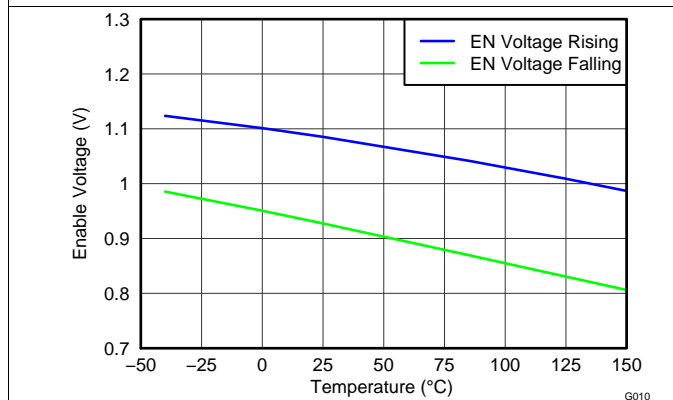

Figure 11. Enable Voltage vs Temperature

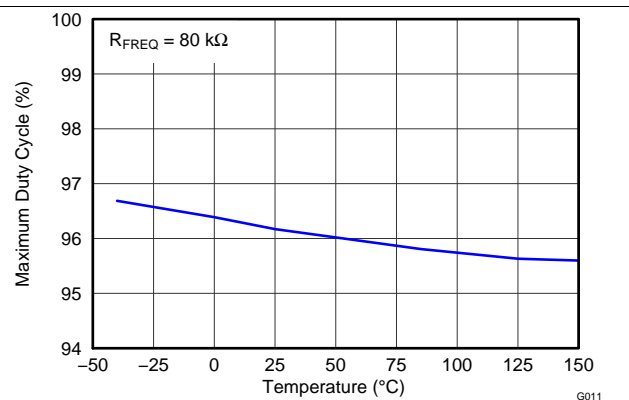
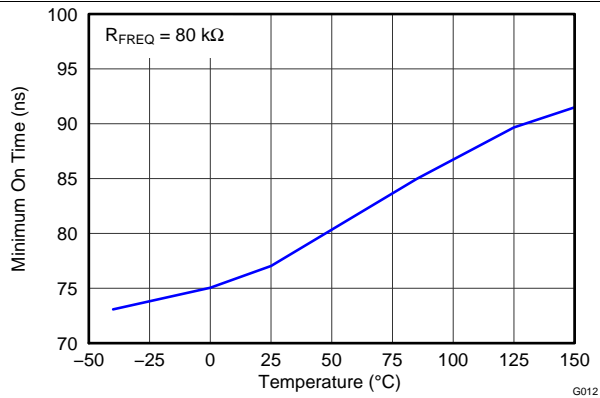

Figure 12. Maximum Duty Cycle vs Temperature

**Typical Characteristics (continued)**

$V_{IN} = 5\text{ V}$ ,  $T_A = 25^\circ\text{C}$  (unless otherwise noted)



**Figure 13. Minimum On Time vs Temperature**

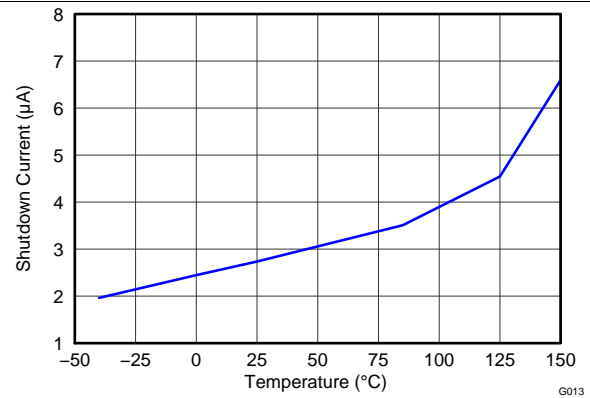

**Figure 14. Shutdown Current vs Temperature**

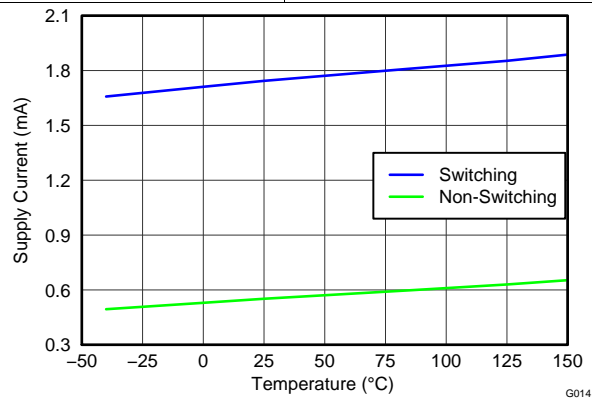

**Figure 15. Supply Current vs Temperature**

## 7 Detailed Description

### 7.1 Overview

The TPS55330 device is a monolithic nonsynchronous switching regulator with an integrated 5-A, 24-V power switch. The device can be configured in several standard switching-regulator topologies, including boost, SEPIC, and isolated flyback. The device has a wide input voltage range to support applications with input voltage from multicell batteries or regulated 3.3-V, 5-V, and 12-V power rails.

### 7.2 Functional Block Diagram

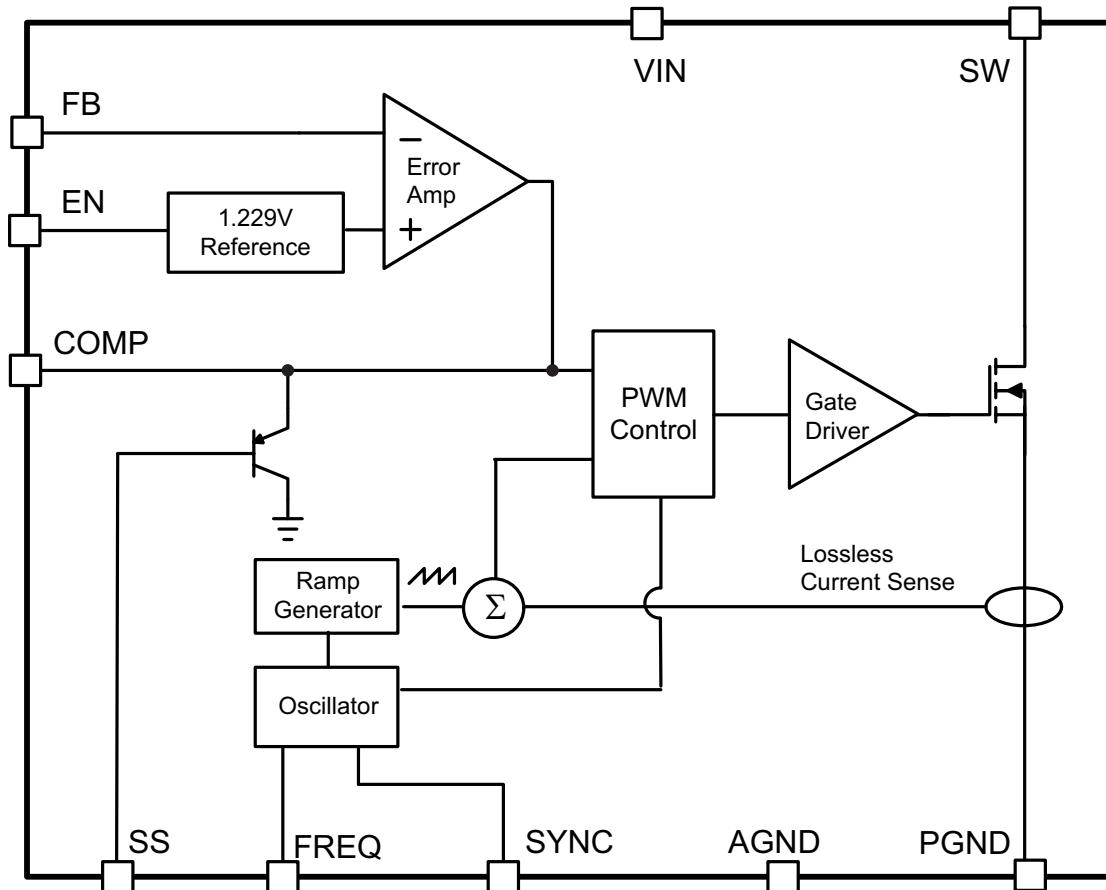

### 7.3 Feature Description

#### 7.3.1 Operation

If designed as a boost converter, the TPS55330 device regulates the output with current-mode pulse-width-modulation (PWM) control. The PWM-control circuitry turns on the switch at the beginning of each oscillator clock cycle. The input voltage is applied across the inductor and stores the energy as inductor current ramps up. During this portion of the switching cycle, the load current is provided by the output capacitor. When the inductor current reaches a threshold level set by the error amplifier output, the power switch turns off and the external Schottky diode is forward biased to allow the inductor current to flow to the output. The inductor transfers stored energy to replenish the output capacitor and supply the load current. This operation repeats every switching cycle. The duty cycle of the converter is determined by the PWM-control comparator which compares the error amplifier output and the current signal. The oscillator frequency is programmed by the external resistor or synchronized to an external clock signal.

## Feature Description (continued)

A ramp signal from the oscillator is added to the inductor current ramp to provide slope compensation. Slope compensation is required to avoid subharmonic oscillation that is intrinsic to peak-current mode control at duty cycles higher than 50%. If the inductor value is too small, the internal slope compensation may not be adequate to maintain stability.

The PWM control feedback loop regulates the FB pin to a reference voltage through a transconductance error amplifier. The output of the error amplifier is connected to the COMP pin. An external RC-compensation network connected to the COMP pin is chosen for feedback loop stability and optimum transient response.

### 7.3.2 Switching Frequency

The switching frequency is set by a resistor ( $R_{\text{FREQ}}$ ) connected to the FREQ pin of the TPS55330. The relationship between the timing resistance  $R_{\text{FREQ}}$  and frequency is shown in the [Figure 5](#). Do not leave this pin open. A resistor must always be connected from the FREQ pin to ground for proper operation. The resistor value required for a desired frequency can be calculated using [Equation 1](#).

$$R_{\text{FREQ}}(\text{k}\Omega) = 57500 \times f_{\text{sw}}(\text{kHz})^{-1.03} \quad (1)$$

For the given resistor value, the corresponding frequency can be calculated by [Equation 2](#).

$$f_{\text{sw}}(\text{kHz}) = 41600 \times R_{\text{FREQ}}(\text{k}\Omega)^{-0.97} \quad (2)$$

The TPS55330 switching frequency can be synchronized to an external clock signal that is applied to the SYNC pin. The required logic levels of the external clock are shown in the specification table. The recommended duty cycle of the clock is in the range of 10% to 90%. A resistor must be connected from the FREQ pin to ground when the converter is synchronized to the external clock and the external clock frequency must be within  $\pm 20\%$  of the corresponding frequency set by the resistor. For example, if the frequency programmed by the FREQ pin resistor is 600kHz, the external clock signal should be in the range of 480kHz to 720kHz.

With a switching frequency below 280 kHz (typical) after the TPS55330 enters frequency foldback as described in the section, if a load remains when the overcurrent condition is removed the output may not recover to the set value. For the output to return to the set value the load must be removed completely or the TPS55330 power cycled with the EN pin or VIN pin. Select a nominal switching frequency of 350 kHz for quicker recovery from frequency foldback.

### 7.3.3 Overcurrent Protection and Frequency Foldback

The TPS55330 provides cycle-by-cycle over-current protection that turns off the power switch once the inductor current reaches the over-current limit threshold. The PWM circuitry resets itself at the beginning of the next switch cycle. During an over-current event, the output voltage begins to droop as a function of the load on the output. When the FB voltage through the feedback resistors, drops lower than 0.9 V, the switching frequency is automatically reduced to 1/4 of the normal value. [Figure 8](#) shows the non-foldback frequency with an 80k $\Omega$  timing resistor and the corresponding foldback frequency. The switching frequency does not return to normal until the over-current condition is removed and the FB voltage increases above 0.9 V. The frequency foldback feature is disabled during soft-start.

#### 7.3.3.1 Minimum On-Time and Pulse Skipping

The TPS55330 PWM control system has a minimum PWM pulse width of 77ns (typical). This minimum on-time determines the minimum duty cycle of the PWM, for any set switching frequency. When the voltage regulation loop of the TPS55330 requires a minimum on-time pulse width less than 77ns, the IC enters pulse-skipping mode. In this mode, the device will hold the power switch off for several switching cycles to prevent the output voltage from rising above the desired regulated voltage. This operation typically occurs in light load conditions when the PWM operates in discontinuous conduction mode. Pulse skipping increases the output ripple as shown in [Figure 22](#).

### 7.3.4 Voltage Reference and Setting Output Voltage

An internal voltage reference provides a precise 1.229 V voltage reference at the error amplifier non-inverting input. To set the output voltage, select the FB pin resistor  $R_{\text{SH}}$  and  $R_{\text{SL}}$  according to [Overcurrent Protection and Frequency Foldback](#).

## Feature Description (continued)

$$V_{OUT} = 1.229 V \times \left( \frac{R_{SH}}{R_{SL}} + 1 \right) \quad (3)$$

### 7.3.5 Soft-Start

The TPS55330 has a built-in soft-start circuit which significantly reduces the start-up current spike and output voltage overshoot. When the IC is enabled, an internal bias current source (6  $\mu$ A typical) charges a capacitor ( $C_{SS}$ ) on the SS pin. The voltage at the capacitor clamps the output of the internal error amplifier that determines the peak current and duty cycle of PWM controller. Limiting the peak switch current during start-up with a slow ramp on the SS pin will reduce in-rush current and output voltage overshoot. Once the capacitor reaches 1.8V, the soft-start cycle is completed and the soft-start voltage no longer clamps the error amplifier output. When the EN is pulled low for at least 1ms, the IC enters the shutdown mode and the SS capacitor is discharged through a 5k $\Omega$  resistor to prepare for the next soft-start sequence.

### 7.3.6 Slope Compensation

The TPS55330 has internal slope compensation to prevent subharmonic oscillations. The sensed current slope of boost converter can be expressed as Equation 4:

$$S_n = \frac{V_{IN}}{L} \times R_{SENSE} \quad (4)$$

The slope compensation dv/dt can be calculated using Equation 5.

$$S_e = \frac{0.32 V/R_{FREQ}}{16 \times (1-D) \times 6 \text{ pF}} + \frac{0.5 \mu\text{A}}{6 \text{ pF}} \quad (5)$$

In a converter with current mode control, in addition to the output voltage feedback loop, the inner current loop including the inductor current sampling effect as well as the slope compensation on the small signal response should be taken into account, which can be modeled as seen in Equation 6:

$$H_e(s) = \frac{1}{1 + \frac{s \times \left[ \left( 1 + \frac{S_e}{S_n} \right) \times (1-D) - 0.5 \right]}{f_{sw}} + \frac{s^2}{(\pi \times f_{sw})^2}}$$

where

- $R_{SENSE}$  (15m $\Omega$ ) is the equivalent current sense resistor
- $R_{FREQ}$  is timing resistor used to set frequency
- D is the duty cycle

---

#### NOTE

If  $S_n \ll S_e$ , the converter operates in voltage mode control rather than current mode control, and Equation 6 is no longer valid.

---

### 7.3.7 Enable and Thermal Shutdown

The TPS55330 enters shutdown when the EN voltage is less than 0.68 V (min) for more than 1 ms. In shutdown, the input supply current for the device is less than 10  $\mu$ A (max). The EN pin has an internal 950k $\Omega$  pull down resistor to disable the device if the pin is floating.

An internal thermal shutdown turns off the device when the junction temperature exceeds 165°C (typical). The device restarts when the junction temperature drops by 15°C.

## Feature Description (continued)

### 7.3.8 Undervoltage Lockout (UVLO)

An under-voltage lockout circuit prevents mis-operation of the device at input voltages below 2.5 V (typical). When the input voltage is below the UVLO threshold, the device remains off and the internal power MOSFET is turned off. The UVLO threshold is set below minimum operating voltage of 2.9 V to ensure that a transient VIN dip will not cause the device to reset. For the input voltages between UVLO threshold and 2.9 V, the device attempts to operate, but the electrical specifications are **not** ensured.

## 7.4 Device Functional Modes

### 7.4.1 Operation With $V_i < 2.9$ V (Minimum $V_i$ )

The TPS55330 device operates with input voltages above 2.9 V. The typical UVLO voltage (turning off) is 2.5 V and the TPS55330 device remains off at input voltages lower than that point. For the input voltages between UVLO threshold and 2.9 V, the device attempts to operate, but the electrical specifications are **not** ensured.

### 7.4.2 Operation With EN Control

The enable rising-edge threshold voltage is 1.08 V (typical) with 0.16 V hysteresis (typical). With the EN pin held below the turn-off voltage the device is disabled and switching is inhibited. The IC quiescent current is reduced in this state. When the input voltage is above the UVLO threshold and the EN pin voltage increases above the rising edge threshold, the device becomes active. Switching enables and the soft-start sequence initiates. The TPS55330 device starts at the soft-start time determined by the external soft-start capacitor.

### 7.4.3 Operation at Light Loads

The device is designed to operate in high-efficiency pulse-skipping mode under light load conditions. Discontinuous-conduction-mode (DCM) operation initiates when the switch current falls to 0 A. During DCM operation, the catch diode stops conducting when the switch current falls to 0 A. The switching node (the SW pin) waveform takes on the characteristics of discontinuous-conduction-mode (DCM) operation. As the load decreases further and when the voltage-regulation loop of TPS55330 device requires an on-time pulse width less than the minimum PWM pulse width of 77 ns (typical), the IC enters pulse-skipping mode. In this mode, the device holds the power switch off for several switching cycles to prevent the output voltage from rising too much above the desired regulated voltage.

## 8 Application and Implementation

### NOTE

Information in the following applications sections is not part of the TI component specification, and TI does not warrant its accuracy or completeness. TI's customers are responsible for determining suitability of components for their purposes. Customers should validate and test their design implementation to confirm system functionality.

### 8.1 Application Information

The TPS55330 device can be configured in several standard switching-regulator topologies, including boost, SEPIC, and isolated flyback. For example, the device configured in boost topology is widely used to convert a lower DC voltage to a higher DC voltage with a maximum available switching current of 5.25 A. Use the following design procedure to select component values for a boost converter design or SEPIC design for the TPS55330 device. Alternately, use the WEBENCH® software to generate a complete design. The WEBENCH software uses an iterative design procedure and accesses a comprehensive database of components when generating a design. This section presents a simplified discussion of the design process.

### 8.2 Typical Application

The following section provides a step-by-step design approach for configuring the TPS55330 as a voltage regulating boost converter, as shown in Figure 16. When configured as SEPIC or flyback converter, a different design approach is required.

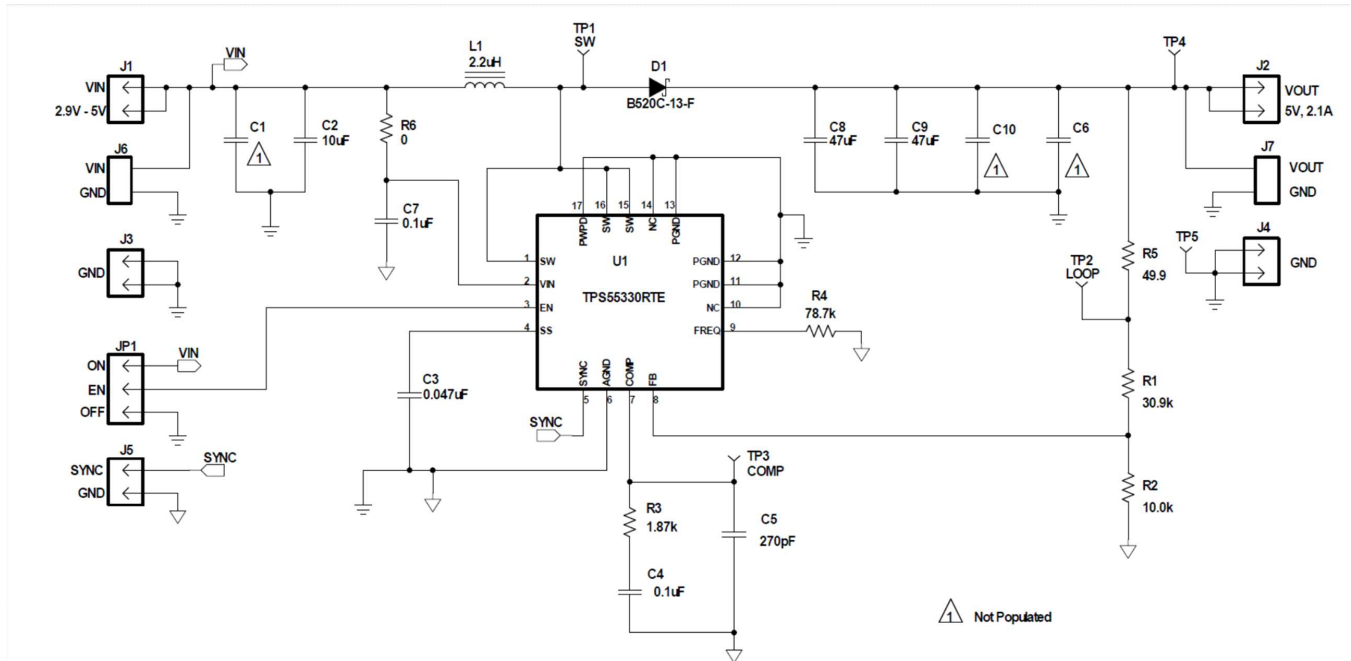

Figure 16. Boost Converter Application Schematic

#### 8.2.1 Design Requirements

PARAMETER	VALUE
Output Voltage	5 V
Input Voltage	2.9 V to 4.2 V
Maximum Output Current	2.1 A
Transient Response 50% load step ( $\Delta V_{OUT} = 3\%$ )	200 mV
Output Voltage Ripple (0.5% of $V_{OUT}$ )	25 mV

## 8.2.2 Detailed Design Procedure

### 8.2.2.1 Custom Design With WEBENCH® Tools

[Click here](#) to create a custom design using the TPS55330 device with the WEBENCH® Power Designer.

1. Start by entering the input voltage ( $V_{IN}$ ), output voltage ( $V_{OUT}$ ), and output current ( $I_{OUT}$ ) requirements.
2. Optimize the design for key parameters such as efficiency, footprint, and cost using the optimizer dial.
3. Compare the generated design with other possible solutions from Texas Instruments.

The WEBENCH Power Designer provides a customized schematic along with a list of materials with real-time pricing and component availability.

In most cases, these actions are available:

- Run electrical simulations to see important waveforms and circuit performance
- Run thermal simulations to understand board thermal performance
- Export customized schematic and layout into popular CAD formats
- Print PDF reports for the design, and share the design with colleagues

Get more information about WEBENCH tools at [www.ti.com/WEBENCH](http://www.ti.com/WEBENCH).

### 8.2.2.2 Selecting the Switching Frequency (R4)

The first step is to decide on a switching frequency for the regulator. There are tradeoffs to consider for a higher or lower switching frequency. A higher switching frequency allows for lower valued inductor and smaller output capacitors leading to the smallest solution size. A lower switching frequency will result in a larger solution size but better efficiency. The user will typically set the frequency for the minimum tolerable efficiency to avoid excessively large external components.

A switching frequency of 600 kHz is a good trade-off between efficiency and solution size. The appropriate resistor value is found from the resistance versus frequency graph of [Figure 5](#), or calculated using [Equation 1](#). R4 is calculated to be 78.4 k $\Omega$  and the nearest standard value resistor of 78.7 k $\Omega$  is selected. A resistor must be placed from the FREQ pin to ground, even if an external oscillation is applied for synchronization.

### 8.2.2.3 Determining the Duty Cycle

The input to output voltage conversion ratio of the TPS55330 is limited by the worst case maximum duty cycle of 89% and the minimum duty cycle which is determined by the minimum on-time of 77 ns and the switching frequency. The minimum duty cycle can be estimated with [Equation 7](#). With a 600 kHz switching frequency the minimum duty cycle is 4%.

$$D_{PS} = T_{ON\ min} \times f_{sw} \quad (7)$$

The duty cycle at which the converter operates is dependent on the mode in which the converter is running. If the converter is running in discontinuous conduction mode (DCM), where the inductor current ramps to zero at the end of each cycle, the duty cycle varies with changes of the load much more than it does when running in continuous conduction mode (CCM). In continuous conduction mode, where the inductor maintains a minimum dc current, the duty cycle is related primarily to the input and output voltages as computed in [Equation 8](#). Assume a 0.5 V drop  $V_D$  across the Schottky rectifier. At the minimum input of 2.9 V, the duty cycle will be 47%. At the maximum input of 4.2 V, the duty cycle is 24%.

$$D = \frac{V_{OUT} + V_D - V_{IN}}{V_{OUT} + V_D} \quad (8)$$

At light loads the converter will operate in DCM. In this case the duty cycle is a function of the load, input and output voltages, inductance and switching frequency as computed in [Equation 9](#). This can be calculated only after an inductance is chosen in the following section. While operating in DCM with very light load conditions the duty cycle demand will force the TPS55330 to operate with the minimum on time. The converter will then begin pulse skipping which can increase the output ripple.

$$D = \frac{\sqrt{2 \times (V_{OUT} + V_D - V_{IN}) \times L \times I_{OUT} \times f_{sw}}}{V_{IN}} \quad (9)$$

All converters using a diode as the freewheeling or catch component have a load current level at which they transit from discontinuous conduction mode to continuous conduction mode. This is the point where the inductor current just falls to zero during the off-time of the power switch. At higher load currents, the inductor current does not fall to zero and diode and switch current assume a trapezoidal wave shape as opposed to a triangular wave shape. The load current boundary between discontinuous conduction and continuous conduction can be found for a set of converter parameters as shown in [Equation 10](#).

$$I_{OUT(crit)} = \frac{(V_{OUT} + V_D - V_{IN}) \times V_{IN}^2}{2 \times (V_{OUT} + V_D)^2 \times f_{SW} \times L} \quad (10)$$

For loads higher than the result of the [Equation 10](#), the duty cycle is given by [Equation 8](#). For loads less than the results of [Equation 10](#), the duty cycle is given [Equation 9](#). For [Equation 7](#) through [Equation 10](#), the variable definitions are as follows.

- $V_{OUT}$  is the output voltage of the converter in V
- $V_D$  is the forward conduction voltage drop across the rectifier or catch diode in V
- $V_{IN}$  is the input voltage to the converter in V
- $I_{OUT}$  is the output current of the converter in A
- L is the inductor value in H
- $f_{SW}$  is the switching frequency in Hz

Unless otherwise stated, the design equations that follow assume that the converter is running in continuous conduction mode, which typically results in a higher efficiency for the power levels of this converter.

#### 8.2.2.4 Selecting the Inductor (L1)

The selection of the inductor affects steady state operation as well as transient behavior and loop stability. These factors make it the most important component in power regulator design. There are three important inductor specifications: inductor value, DC resistance and saturation current. Considering inductor value alone is not enough. Inductor values can have  $\pm 20\%$  tolerance with no current bias. When the inductor current approaches saturation level, the effective inductance can fall to a fraction of the zero current value.

The minimum value of the inductor should be able to meet inductor current ripple ( $\Delta I_L$ ) requirement at worst case. In a boost converter, maximum inductor current ripple occurs at 50% duty cycle. For the applications where duty cycle is always smaller or larger than 50%, [Equation 12](#) should be used with the duty cycle closest to 50% and corresponding input voltage to calculate the minimum inductance. For applications that need to operate with 50% duty cycle when input voltage is somewhere between the minimum and the maximum input voltage, [Equation 13](#) should be used.  $K_{IND}$  is a coefficient that represents the amount of inductor ripple current relative to the maximum input current ( $I_{INDC} = I_{Lavg}$ ). The maximum input current can be estimated with [Equation 11](#), with an estimated efficiency based on similar applications ( $\eta_{EST}$ ). The inductor ripple current will be filtered by the output capacitor. Therefore, choosing high inductor ripple currents will impact the selection of the output capacitor since the output capacitor must have a ripple current rating equal to or greater than the inductor ripple current. In general, the inductor ripple value ( $K_{IND}$ ) is at the discretion of the designer. However, the following guidelines may be used.

For CCM operation, it is recommended to use  $K_{IND}$  values in the range of 0.2 to 0.4. Choosing  $K_{IND}$  closer to 0.2 results in a larger inductance value, maximizes the converter's potential output current and minimizes EMI. Choosing  $K_{IND}$  closer to 0.4 results in a smaller inductance value, a physically smaller inductor, and improved transient response, but potentially worse EMI and lower efficiency. Using an inductor with a smaller inductance value may result in the converter operating in DCM. This reduces the boost converter's maximum output current, causes larger input voltage and output voltage ripple and reduced efficiency. For this design, choose  $K_{IND} = 0.3$  and a conservative efficiency estimate of 85% with the minimum input voltage and maximum output current. [Equation 12](#) is used with the minimum input voltage because this corresponds to duty cycle closest to 50%. The maximum input current is estimated at 4.53A and the minimum inductance is 1.68  $\mu$ H. A standard value of 2.2  $\mu$ H is chosen.

$$I_{INDC} = \frac{V_{OUT} \times I_{OUT}}{\eta_{EST} \times V_{IN \min}} \quad (11)$$

$$L_O \min \geq \frac{V_{IN}}{I_{INDC} \times K_{IND}} \times \frac{D}{f_{SW}}, \quad D \neq 50\%, \quad V_{IN} \text{ with } D \text{ closest to } 50\% \quad (12)$$

$$L_O \min \geq \frac{(V_{OUT} + V_D)}{I_{INDC} \times K_{IND}} \times \frac{1}{4 \times f_{SW}}, D=50\% \quad (13)$$

After choosing the inductance, the required current ratings can be calculated. The inductor will be closest to its ratings with the minimum input voltage. The ripple with the chosen inductance is calculated with Equation 14. The RMS and peak inductor current can be found with Equation 15 and Equation 16. For this design the current ripple is 1.04 A, the RMS inductor current is 4.53 A, and the peak inductor current is 5.05 A. It is generally recommended for the peak inductor current rating of the selected inductor be 20% higher to account for transients during power up, faults or transient load conditions. The most conservative approach is to specify an inductor with a saturation current greater than the maximum peak current limit of the TPS55330. This helps to avoid saturation of the inductor. The chosen inductor is a Würth Elektronik 74437346022. It has a saturation current rating of 15 A, RMS current rating of 6.5 A, and typical DCR of 18 mΩ.

$$\Delta I_L = \frac{V_{IN \min}}{L_O} \times \frac{D_{max}}{f_{SW}} \quad (14)$$

$$I_{L \text{ rms}} = \sqrt{(I_{INDC})^2 + \frac{\Delta I_L^2}{12}} \quad (15)$$

$$I_{L \text{ peak}} = I_{INDC} + \frac{\Delta I_L}{2} \quad (16)$$

The TPS55330 has built-in slope compensation to avoid subharmonic oscillation associated with current mode control. If the inductor value is too small, the slope compensation may not be adequate, and the loop can be unstable.

### 8.2.2.5 Computing the Maximum Output Current

The over-current limit for the integrated power MOSFET limits the maximum input current and thus the maximum input power for a given input voltage. Maximum output power is less than maximum input power due to power conversion losses. Therefore, the current limit setting, input voltage, output voltage and efficiency can all change maximum current output ( $I_{OUT \text{ max}}$ ). The current limit clamps the peak inductor current, therefore the ripple has to be subtracted to derive maximum DC current. Decreasing the  $K_{IND}$  or designing for a higher efficiency will increase the maximum output current. This can be evaluated with the chosen inductance or the chosen  $K_{IND}$ . This should be evaluated with the minimum input voltage and minimum peak current limit ( $I_{LIM}$ ) of 5.25 A.

$$I_{OUT \text{ max}} = \frac{V_{IN \min} \times \left( I_{LIM} - \frac{\Delta I_L}{2} \right) \times \eta_{EST}}{V_{OUT}} = \frac{V_{IN \min} \times I_{LIM} \times \eta_{EST}}{\left( 1 + \frac{K_{IND}}{2} \right) \times V_{OUT}} \quad (17)$$

In this design with 2.9 V input boosted to 5 V output and a 2.2 μH inductor with an assumed the Schottky forward voltage of 0.5 V and estimated efficiency of 80%, the maximum output current is 2.25 A. With the 4.2 V input and increased estimated efficiency of 90%, the maximum output current increases to 3.68 A.

### 8.2.2.6 Selecting the Output Capacitor (C8-C10)

At least 4.7 μF of ceramic type X5R or X7R capacitance is recommended at the output. The output capacitance is mainly selected to meet the requirements for the output ripple ( $V_{RIPPLE}$ ) and voltage change during a load transient. Then the loop is compensated for the output capacitor selected. The output capacitance should be chosen based on the most stringent of these criteria. The output ripple voltage is related to the capacitance and equivalent series resistance (ESR) of the output capacitor. Assuming a capacitor with zero ESR, the minimum capacitance needed for a given ripple can be calculated by Equation 18. If high ESR capacitors are used it will contribute additional ripple. The maximum ESR for a specified ripple is calculated with Equation 19. ESR ripple can be neglected for ceramic capacitors but must be considered if tantalum or electrolytic capacitors are used. The minimum ceramic output capacitance needed to meet a load transient requirement can be estimated by the Equation 20. Equation 21 can be used to calculate the RMS current that the output capacitor needs to support.

$$C_{OUT} \geq \frac{D_{max} \times I_{OUT}}{f_{SW} \times V_{RIPPLE}} \quad (18)$$

$$ESR = \frac{\left( V_{RIPPLE} - \frac{D_{max} \times I_{OUT}}{f_{SW} \times C_{OUT}} \right)}{I_{L,peak}} \quad (19)$$

$$C_{OUT} \geq \frac{\Delta I_{TRAN}}{2 \times \pi \times f_{BW} \times \Delta V_{TRAN}} \quad (20)$$

$$I_{CO,rms} = I_{OUT} \sqrt{\frac{D_{max}}{(1-D_{max})}} \quad (21)$$

Using Equation 18 for this design, the minimum output capacitance for the specified 25 mV output ripple is 66  $\mu$ F. For a maximum transient voltage change ( $\Delta V_{TRAN}$ ) of 200 mV with a 1 mA load transient ( $\Delta I_{TRAN}$ ) and a 10 kHz control loop bandwidth ( $f_{BW}$ ) with Equation 20, the minimum output capacitance is 84  $\mu$ F. The most stringent criteria is the 66  $\mu$ F for the required load transient. Equation 21 gives a 2 A RMS current in the output capacitor. The capacitor should also be properly rated for the desired output voltage.

Care must be taken when evaluating ceramic capacitors that derate under dc bias, aging and AC signal conditions. For example, larger form factor capacitors (in 1206 size) have self-resonant frequencies in the range of converter switching frequency. Self-resonance causes the effective capacitance to be significantly lower. The DC bias can also significantly reduce capacitance. Ceramic capacitors can lose as much as 50% of the capacitance when operated at the rated voltage. Therefore, allow margin in selected capacitor voltage rating to ensure adequate capacitance at the required output voltage. For this example, two 47  $\mu$ F, 16 V 1210 X5R ceramic capacitors are used in parallel leading to a negligible ESR. Choosing 16 V capacitors instead of 6.3 V reduces the effects of DC bias and allows this example circuit to be rated for the maximum output voltage range of the TPS55330.

### 8.2.2.7 Selecting the Input Capacitors (C2, C7)

At least 4.7 $\mu$ F of ceramic input capacitance is recommended. Additional input capacitance may be required to meet ripple and/or transient requirements. High quality ceramic, type X5R or X7R are recommended to minimize capacitance variations over temperature. The capacitor must also have an RMS current rating greater than the maximum RMS input current of the TPS55330 calculated with Equation 22. The input capacitor must also be rated greater than the maximum input voltage. The input voltage ripple can be calculated with Equation 23.

$$I_{CI,rms} = \frac{\Delta I_L}{\sqrt{12}} \quad (22)$$

$$V_{ripple} = \frac{\Delta I_L}{4 \times f_{SW} \times C_{IN}} + \Delta I_L \times R_{CIN} \quad (23)$$

In the design example, the input RMS current is calculated to be 300 mA. The chosen input capacitor is a 10  $\mu$ F, 25 V 1210 X7R with 3 m $\Omega$  ESR. Although one with a lower voltage rating can be used, a 25 V rated capacitor was chosen to limit the affects of dc bias and to allow it the circuit to be rated for the entire input range of the TPS55330. The input ripple is calculated to be 46 mV. An additional 0.1  $\mu$ F, 50 V 0603 X5R is located close to the VIN and GND pins for extra decoupling.

### 8.2.2.8 Setting Output Voltage (R1, R2)

To set the output voltage in either DCM or CCM, select the values of R1 and R2 according to the following equations.

$$V_{OUT} = 1.229 V \times \left( \frac{R1}{R2} + 1 \right) \quad (24)$$

$$R1 = R2 \times \left( \frac{V_{OUT}}{1.229 V} - 1 \right) \quad (25)$$

Considering the leakage current through the resistor divider and noise decoupling into FB pin, an optimum value for R2 is around 10 k $\Omega$ . The output voltage tolerance depends on the  $V_{FB}$  accuracy and the tolerance of R1 and R2. In this example with a 5-V output using Equation 25, R1 is calculated to 30.7 k $\Omega$ . The nearest standard value of 30.9 k $\Omega$  is used.

### 8.2.2.9 Setting the Soft-start Time (C7)

Choose the appropriate capacitor to set soft-start time and avoid overshoot. Increasing the soft-start time reduces the overshoot during start-up. A 0.047  $\mu\text{F}$  ceramic capacitor is used in this example.

### 8.2.2.10 Selecting the Schottky Diode (D1)

The high switching frequency of the TPS55330 demands high-speed rectification for optimum efficiency. Ensure that the diode's average and peak current rating exceed the average output current and peak inductor current. In addition, the diode's reverse breakdown voltage must exceed the regulated output voltage. The diode must also be rated for the power dissipated which can be calculated with Equation 26.

$$P_D = V_D \times I_{OUT} \quad (26)$$

In this conservative design example, the diode is chosen to be rated for the maximum output current of 3.6 A. During normal operation with 2.1 mA output current and assuming a Schottky diode drop of 0.5 V, the diode must be capable of dissipating 1 W. The recommended minimum ratings for this design are a 20 V, 4 A diode. However to improve the flexibility of this design, a Diodes Inc B520-13-F in an SMC package is used with voltage and current ratings of 20 V and 5 A.

### 8.2.2.11 Compensating the Control Loop (R3, C4, C5)

The TPS55330 requires external compensation which allows the loop response to be optimized for each application. The COMP pin is the output of the internal error amplifier. An external resistor R3 and ceramic capacitor C4 are connected to the COMP pin to provide a pole and a zero, shown in the application circuit. This pole and zero, along with the inherent pole and zero of a boost converter, determine the closed loop frequency response. This is important for converter stability and transient response. Loop compensation should be designed for the minimum operating voltage.

The following equations summarize the loop equations for the TPS55330 configured as a CCM boost converter. They include the power stage output pole ( $f_{OUT}$ ) and the right-half-plane zero ( $f_{RHPZ}$ ) of a boost converter calculated with Equation 27 and Equation 28 respectively. When calculating  $f_{OUT}$  it is important to include the derating of ceramic output capacitors. In the example with an estimated 61  $\mu\text{F}$  capacitance, these frequencies are calculated to 521 kHz and 2.2 kHz respectively. The DC gain (A) of the power stage is calculated with Equation 29 and is 39.9 dB in this design. The compensation pole ( $f_P$ ) and zero ( $f_Z$ ) generated by R3, C4 and internal transconductance amplifier are calculated with Equation 30 and Equation 31, respectively.

Most CCM boost converters will have a stable control loop if  $f_Z$  is set slightly above  $f_P$  through proper sizing of R3 and C4. A good starting point is  $C4 = 0.1 \mu\text{F}$  and  $R3 = 2\text{k}\Omega$ . Increasing R3 or reducing C4 increases the closed loop bandwidth, and therefore improves the transient response. Adjusting R3 and C4 in opposite direction increases the phase and gain margin of the loop, which improves loop stability. It is generally recommended to limit the bandwidth of the loop to the lower of either 1/5 of the switching frequency  $f_{SW}$  or 1/3 the RHPZ frequency,  $f_{RHPZ}$  shown in Equation 28. The spreadsheet tool located in the TPS55330 product folder at SLVC430 can also be used to aid in compensation design.

$$f_{OUT} \approx \frac{2}{2\pi \times R_{OUT} \times C_{OUT}} \quad (27)$$

$$f_{RHPZ} \approx \frac{R_{OUT}}{2\pi \times L} \times \left( \frac{V_{IN}}{V_{OUT}} \right)^2 \quad (28)$$

$$A = \frac{1.229}{V_{OUT}} \times G_{ea} \times 10\text{M}\Omega \times \frac{V_{IN}}{V_{OUT} \times R_{SENSE}} \times R_{OUT} \times \frac{1}{2} \quad (29)$$

$$f_P = \frac{1}{2\pi \times 10\text{M}\Omega \times C4} \quad (30)$$

$$f_Z = \frac{1}{2\pi \times R3 \times C4} \quad (31)$$

$$f_{co1} = \frac{f_{SW}}{5} \quad (32)$$

$$f_{co2} = \frac{f_{RHPZ}}{3} \quad (33)$$

Where

- $C_{OUT}$  is the equivalent output capacitor ( $C_{OUT}=C8+C9+C10$ )
- $R_{OUT}$  is the equivalent load resistance ( $V_{OUT}/I_{OUT}$ )
- $G_{ea}$  is the error amplifier transconductance located in the [Electrical Characteristics](#) table
- $R_{SENSE}$  (15 mΩ, typical) is the sense resistor in the current control loop
- $f_{co1}$  and  $f_{co2}$  are possible bandwidth.

An additional capacitor from the COMP pin to GND (C5) can be used to place a high frequency pole in the control loop. This is not always necessary with ceramic output capacitors. If a nonceramic output capacitor is used, there is an additional zero ( $f_{ZESR}$ ) in the control loop which can be calculated with [Equation 35](#). The value of C5 and the pole created by C5 can be calculated with [Equation 36](#) and [Equation 34](#) respectively. Finally if more phase margin is needed, an additional zero ( $f_{ZFF}$ ) can be added by placing a capacitor ( $C_{FF}$ ) in parallel with the top feedback resistor R1. TI recommends placing the zero at the target cross-over frequency or higher. The feed forward capacitor also adds a pole at a higher frequency. The recommended value of  $C_{FF}$  can be calculated with [Equation 37](#).

$$f_{P2} = \frac{1}{2\pi \times R3 \times C5} \tag{34}$$

$$f_{ZESR} \approx \frac{1}{2\pi \times R_{ESR} \times C_{OUT}} \tag{35}$$

$$C5 = \frac{R_{ESR} \times C_{OUT}}{R3} \tag{36}$$

$$C_{FF} = \frac{1}{2\pi \times R1 \times f_{ZFF} \times \sqrt{\frac{V_{REF}}{V_{OUT}}}} \tag{37}$$

where  $R_{ESR}$  is the ESR of the output capacitor.

If a network measurement tool is available, the most accurate compensation design can be achieved following this procedure. The power stage frequency response is first measured using a network analyzer at the 3.6 V input and maximum 2.1 A load. This measurement is shown in [Figure 17](#). In this design only one pole and one zero are used, so the maximum phase increase from the compensation will be 180 degrees. For a 60 degree phase margin, the power stage phase must be -120 degrees at its lowest point. Based on the target 10 kHz bandwidth, the measured power stage gain,  $K_{PS}(f_{BW})$ , is 13.3 dB and the phase is -87 degrees.

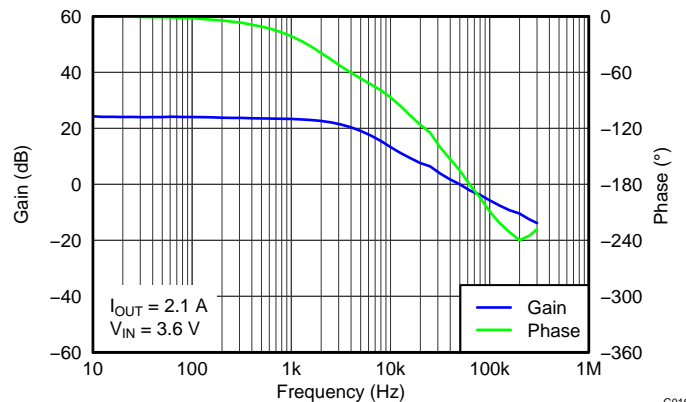

Figure 17. Power Stage Gain and Phase of the Boost Converter

R3 is then chosen to set the compensation gain to be the reciprocal of the power stage gain at the target bandwidth using [Equation 38](#). C4 is then chosen to place a zero at 1/10 the target bandwidth with [Equation 39](#). In this case R3 is calculated to be 1.87 kΩ, the nearest standard value 1.87 kΩ is used. C4 is calculated at 0.085 μF and the nearest standard value 0.100 μF is used. Although not necessary because this design uses all ceramic capacitors, a 270-pF capacitor is selected for C5 to add a high-frequency pole at a frequency 100 times the target bandwidth.

$$R3 = \frac{1}{\left( \text{Gea} \times \frac{R2}{(R1 + R2)} \times 10^{\frac{K_{PS}(f_{BW})}{20}} \right)} \tag{38}$$

$$C4 = \frac{1}{2\pi \times R3 \times \frac{f_{BW}}{10}} \tag{39}$$

### 8.2.3 Application Curves

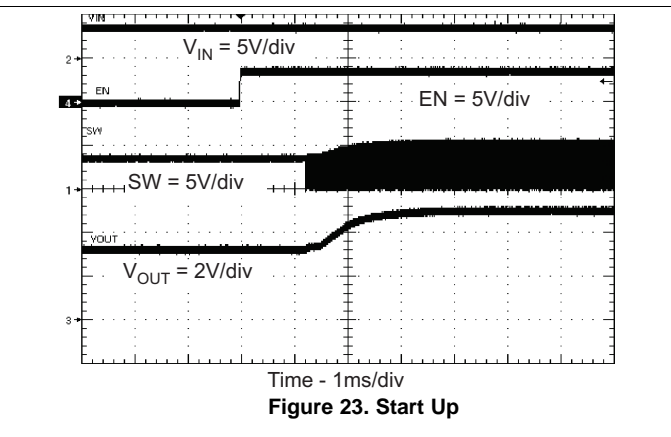
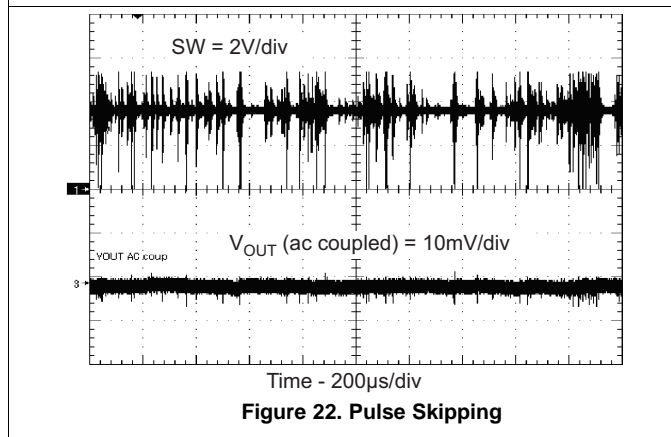
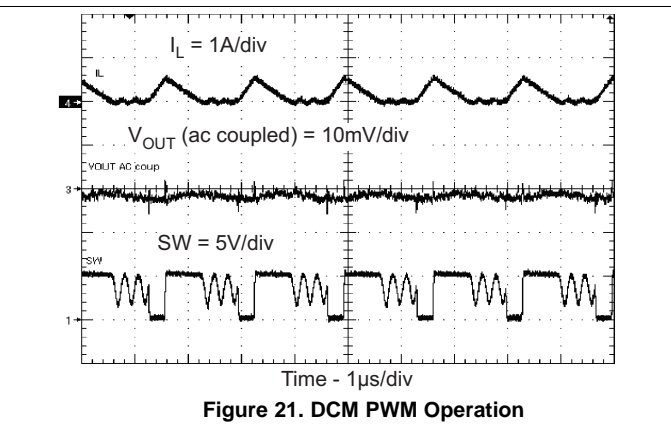
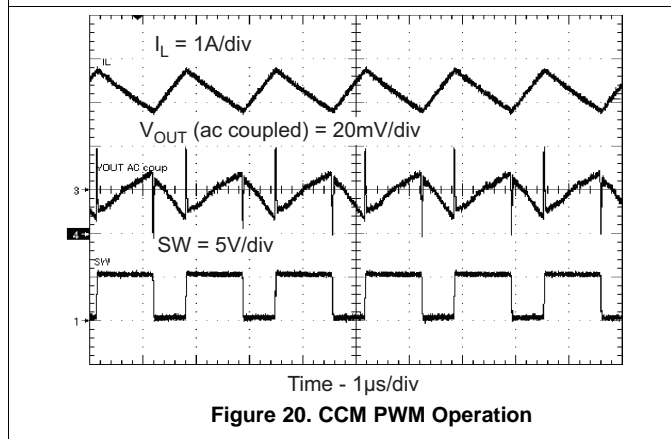
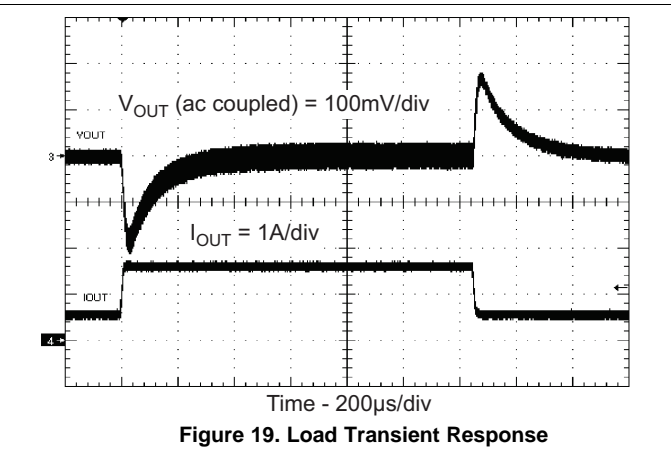
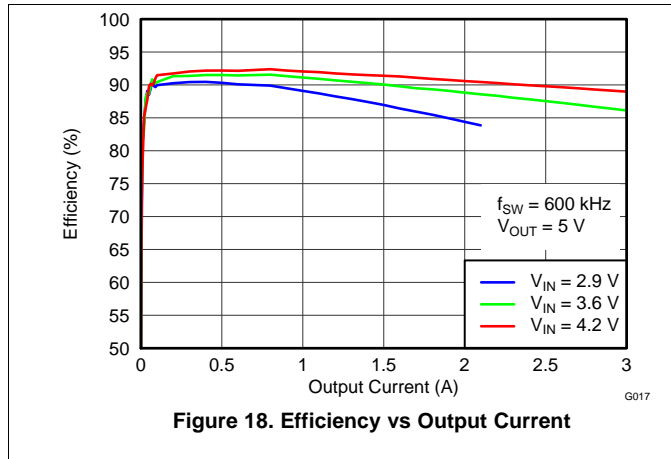

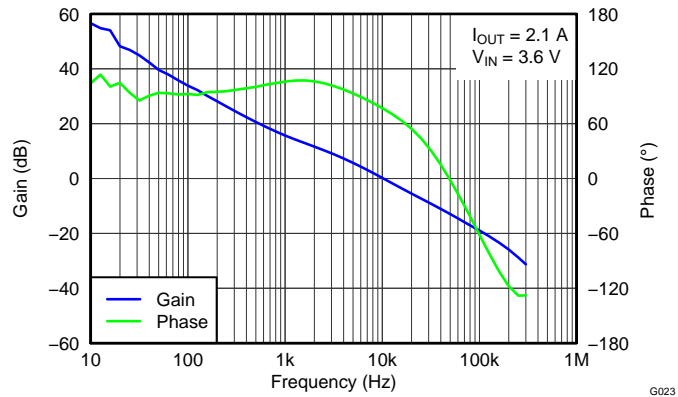

Figure 24. Closed-Loop Gain and Phase of the Boost Converter

## 9 Power Supply Recommendations

The device is designed to operate from an input voltage supply range from 2.9 V to 16 V. This input supply must be well regulated. If the input supply is located more than a few inches from the TPS55330 converter additional bulk capacitance may be required in addition to the ceramic bypass capacitors. An electrolytic capacitor with a value of 100  $\mu\text{F}$  is a typical choice.

## 10 Layout

### 10.1 Layout Guidelines

As for all switching power supplies, especially those with high frequency and high switch current, printed circuit board (PCB) layout is an important design step. If the layout is not carefully designed, the regulator can suffer from instability as well as noise problems. The following guidelines are recommended for good PCB layout.

- To prevent radiation of high frequency resonance problems, use proper layout of the high frequency switching path.
- Minimize the length and area of all traces connected to the SW pin and always use a ground plane under the switching regulator to minimize inter-plane coupling.
- The high current path including the internal MOSFET switch, Schottky diode, and output capacitor, contains nanosecond rise times and fall times. Keep these rise times and fall times as short as possible.
- Place the VIN bypass capacitor as close to the VIN pin and the AGND pin as possible to reduce the IC supply ripple.
- Connect the AGND and PGND pins to thermal pad directly on the same layer.

### 10.2 Layout Example

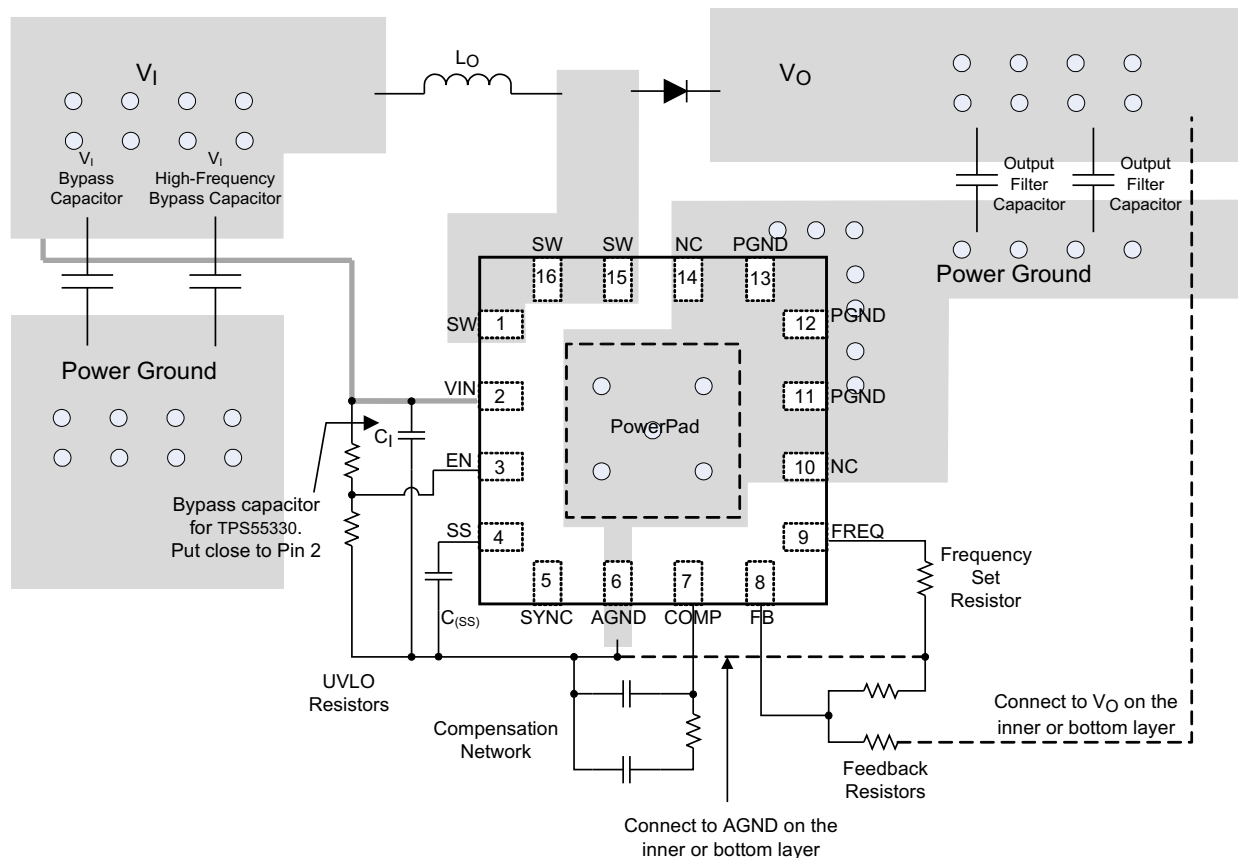

**Figure 25. TPS55330 Example Board Layout**

### 10.3 Thermal Considerations

The maximum IC junction temperature should be restricted to 150°C under normal operating conditions. This restriction limits the power dissipation of the TPS55330. The TPS55330 features a thermally enhanced QFN package. This package includes a PowerPAD that improves the thermal capabilities of the package. The thermal resistance of the QFN package in any application greatly depends on the PCB layout and the PowerPAD connection. The PowerPAD must be soldered to the analog ground on the PCB. Use thermal vias underneath the PowerPAD to achieve good thermal performance.

## 11 Device and Documentation Support

### 11.1 Device Support

#### 11.1.1 Third-Party Products Disclaimer

TI'S PUBLICATION OF INFORMATION REGARDING THIRD-PARTY PRODUCTS OR SERVICES DOES NOT CONSTITUTE AN ENDORSEMENT REGARDING THE SUITABILITY OF SUCH PRODUCTS OR SERVICES OR A WARRANTY, REPRESENTATION OR ENDORSEMENT OF SUCH PRODUCTS OR SERVICES, EITHER ALONE OR IN COMBINATION WITH ANY TI PRODUCT OR SERVICE.

#### 11.1.2 Development Support

##### 11.1.2.1 Custom Design With WEBENCH® Tools

[Click here](#) to create a custom design using the TPS55330 device with the WEBENCH® Power Designer.

1. Start by entering the input voltage ( $V_{IN}$ ), output voltage ( $V_{OUT}$ ), and output current ( $I_{OUT}$ ) requirements.
2. Optimize the design for key parameters such as efficiency, footprint, and cost using the optimizer dial.
3. Compare the generated design with other possible solutions from Texas Instruments.

The WEBENCH Power Designer provides a customized schematic along with a list of materials with real-time pricing and component availability.

In most cases, these actions are available:

- Run electrical simulations to see important waveforms and circuit performance
- Run thermal simulations to understand board thermal performance
- Export customized schematic and layout into popular CAD formats
- Print PDF reports for the design, and share the design with colleagues

Get more information about WEBENCH tools at [www.ti.com/WEBENCH](http://www.ti.com/WEBENCH).

### 11.2 Receiving Notification of Documentation Updates

To receive notification of documentation updates, navigate to the device product folder on ti.com. In the upper right corner, click on *Alert me* to register and receive a weekly digest of any product information that has changed. For change details, review the revision history included in any revised document.

### 11.3 Community Resources

The following links connect to TI community resources. Linked contents are provided "AS IS" by the respective contributors. They do not constitute TI specifications and do not necessarily reflect TI's views; see TI's [Terms of Use](#).

**TI E2E™ Online Community** *TI's Engineer-to-Engineer (E2E) Community*. Created to foster collaboration among engineers. At [e2e.ti.com](http://e2e.ti.com), you can ask questions, share knowledge, explore ideas and help solve problems with fellow engineers.

**Design Support** *TI's Design Support* Quickly find helpful E2E forums along with design support tools and contact information for technical support.

### 11.4 Trademarks

PowerPAD, E2E are trademarks of Texas Instruments.  
 WEBENCH is a registered trademark of Texas Instruments.  
 All other trademarks are the property of their respective owners.

### 11.5 Electrostatic Discharge Caution



These devices have limited built-in ESD protection. The leads should be shorted together or the device placed in conductive foam during storage or handling to prevent electrostatic damage to the MOS gates.

## 11.6 Glossary

[SLYZ022](#) — *TI Glossary*.

This glossary lists and explains terms, acronyms, and definitions.

## 12 Mechanical, Packaging, and Orderable Information

The following pages include mechanical, packaging, and orderable information. This information is the most current data available for the designated devices. This data is subject to change without notice and revision of this document. For browser-based versions of this data sheet, refer to the left-hand navigation.

**PACKAGING INFORMATION**

Orderable Device	Status (1)	Package Type	Package Drawing	Pins	Package Qty	Eco Plan (2)	Lead/Ball Finish (6)	MSL Peak Temp (3)	Op Temp (°C)	Device Marking (4/5)	Samples
TPS55330RTER	ACTIVE	WQFN	RTE	16	3000	Green (RoHS & no Sb/Br)	CU NIPDAU	Level-2-260C-1 YEAR	-40 to 150	55330	<a href="#">Samples</a>
TPS55330RTET	ACTIVE	WQFN	RTE	16	250	Green (RoHS & no Sb/Br)	CU NIPDAU	Level-2-260C-1 YEAR	-40 to 150	55330	<a href="#">Samples</a>

(1) The marketing status values are defined as follows:

**ACTIVE:** Product device recommended for new designs.

**LIFEBUY:** TI has announced that the device will be discontinued, and a lifetime-buy period is in effect.

**NRND:** Not recommended for new designs. Device is in production to support existing customers, but TI does not recommend using this part in a new design.

**PREVIEW:** Device has been announced but is not in production. Samples may or may not be available.

**OBsolete:** TI has discontinued the production of the device.

(2) **RoHS:** TI defines "RoHS" to mean semiconductor products that are compliant with the current EU RoHS requirements for all 10 RoHS substances, including the requirement that RoHS substance do not exceed 0.1% by weight in homogeneous materials. Where designed to be soldered at high temperatures, "RoHS" products are suitable for use in specified lead-free processes. TI may reference these types of products as "Pb-Free".

**RoHS Exempt:** TI defines "RoHS Exempt" to mean products that contain lead but are compliant with EU RoHS pursuant to a specific EU RoHS exemption.

**Green:** TI defines "Green" to mean the content of Chlorine (Cl) and Bromine (Br) based flame retardants meet JS709B low halogen requirements of <=1000ppm threshold. Antimony trioxide based flame retardants must also meet the <=1000ppm threshold requirement.

(3) MSL, Peak Temp. - The Moisture Sensitivity Level rating according to the JEDEC industry standard classifications, and peak solder temperature.

(4) There may be additional marking, which relates to the logo, the lot trace code information, or the environmental category on the device.

(5) Multiple Device Markings will be inside parentheses. Only one Device Marking contained in parentheses and separated by a "~" will appear on a device. If a line is indented then it is a continuation of the previous line and the two combined represent the entire Device Marking for that device.

(6) Lead/Ball Finish - Orderable Devices may have multiple material finish options. Finish options are separated by a vertical ruled line. Lead/Ball Finish values may wrap to two lines if the finish value exceeds the maximum column width.

**Important Information and Disclaimer:**The information provided on this page represents TI's knowledge and belief as of the date that it is provided. TI bases its knowledge and belief on information provided by third parties, and makes no representation or warranty as to the accuracy of such information. Efforts are underway to better integrate information from third parties. TI has taken and continues to take reasonable steps to provide representative and accurate information but may not have conducted destructive testing or chemical analysis on incoming materials and chemicals. TI and TI suppliers consider certain information to be proprietary, and thus CAS numbers and other limited information may not be available for release.

In no event shall TI's liability arising out of such information exceed the total purchase price of the TI part(s) at issue in this document sold by TI to Customer on an annual basis.



**TAPE AND REEL INFORMATION**

**QUADRANT ASSIGNMENTS FOR PIN 1 ORIENTATION IN TAPE**

\*All dimensions are nominal

Device	Package Type	Package Drawing	Pins	SPQ	Reel Diameter (mm)	Reel Width W1 (mm)	A0 (mm)	B0 (mm)	K0 (mm)	P1 (mm)	W (mm)	Pin1 Quadrant
TPS55330RTER	WQFN	RTE	16	3000	330.0	12.4	3.3	3.3	1.1	8.0	12.0	Q2
TPS55330RTET	WQFN	RTE	16	250	180.0	12.4	3.3	3.3	1.1	8.0	12.0	Q2

**TAPE AND REEL BOX DIMENSIONS**



\*All dimensions are nominal

Device	Package Type	Package Drawing	Pins	SPQ	Length (mm)	Width (mm)	Height (mm)
TPS55330RTER	WQFN	RTE	16	3000	367.0	367.0	35.0
TPS55330RTET	WQFN	RTE	16	250	210.0	185.0	35.0

# MECHANICAL DATA

RTE (S-PWQFN-N16)

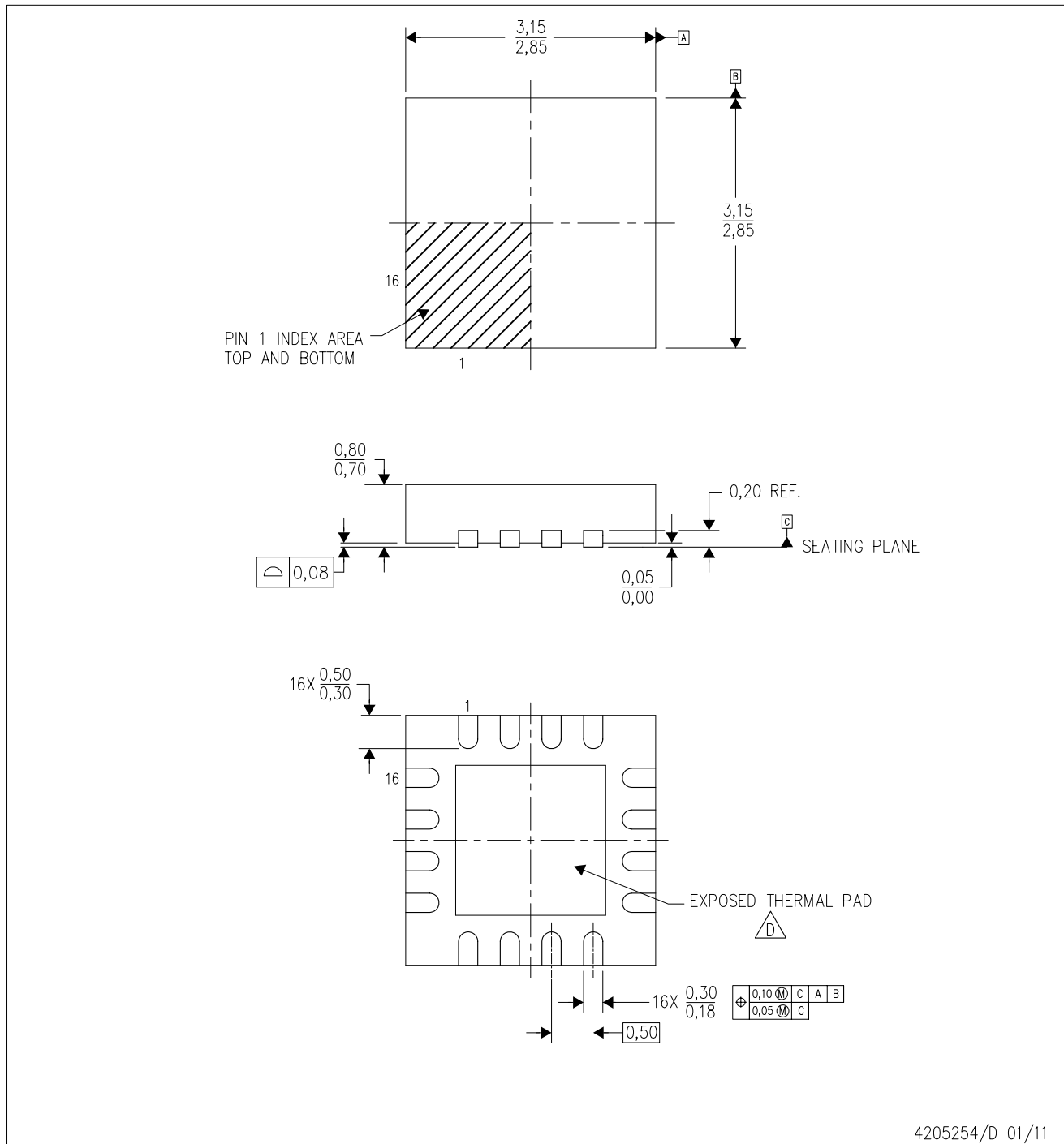
PLASTIC QUAD FLATPACK NO-LEAD



4205254/D 01/11

- NOTES:
- A. All linear dimensions are in millimeters. Dimensioning and tolerancing per ASME Y14.5M-1994.
  - B. This drawing is subject to change without notice.
  - C. Quad Flatpack, No-leads (QFN) package configuration.
  -  The package thermal pad must be soldered to the board for thermal and mechanical performance. See the Product Data Sheet for details regarding the exposed thermal pad dimensions.
  - E. Falls within JEDEC MO-220.

**THERMAL INFORMATION**

This package incorporates an exposed thermal pad that is designed to be attached directly to an external heatsink. The thermal pad must be soldered directly to the printed circuit board (PCB). After soldering, the PCB can be used as a heatsink. In addition, through the use of thermal vias, the thermal pad can be attached directly to the appropriate copper plane shown in the electrical schematic for the device, or alternatively, can be attached to a special heatsink structure designed into the PCB. This design optimizes the heat transfer from the integrated circuit (IC).

For information on the Quad Flatpack No-Lead (QFN) package and its advantages, refer to Application Report, QFN/SON PCB Attachment, Texas Instruments Literature No. SLUA271. This document is available at [www.ti.com](http://www.ti.com).

The exposed thermal pad dimensions for this package are shown in the following illustration.

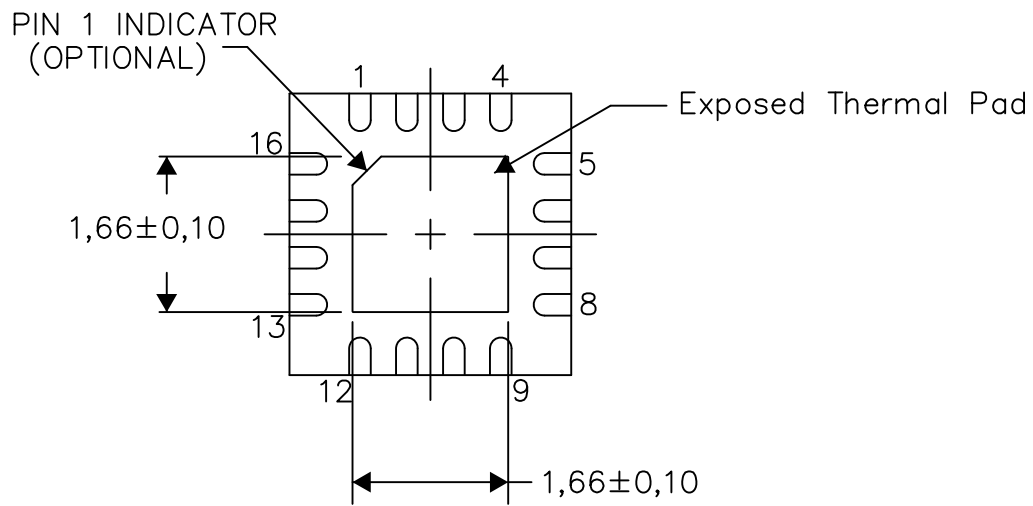

Bottom View

Exposed Thermal Pad Dimensions

4206446-8/U 08/15

NOTE: A. All linear dimensions are in millimeters

RTE (S-PWQFN-N16)

PLASTIC QUAD FLATPACK NO-LEAD

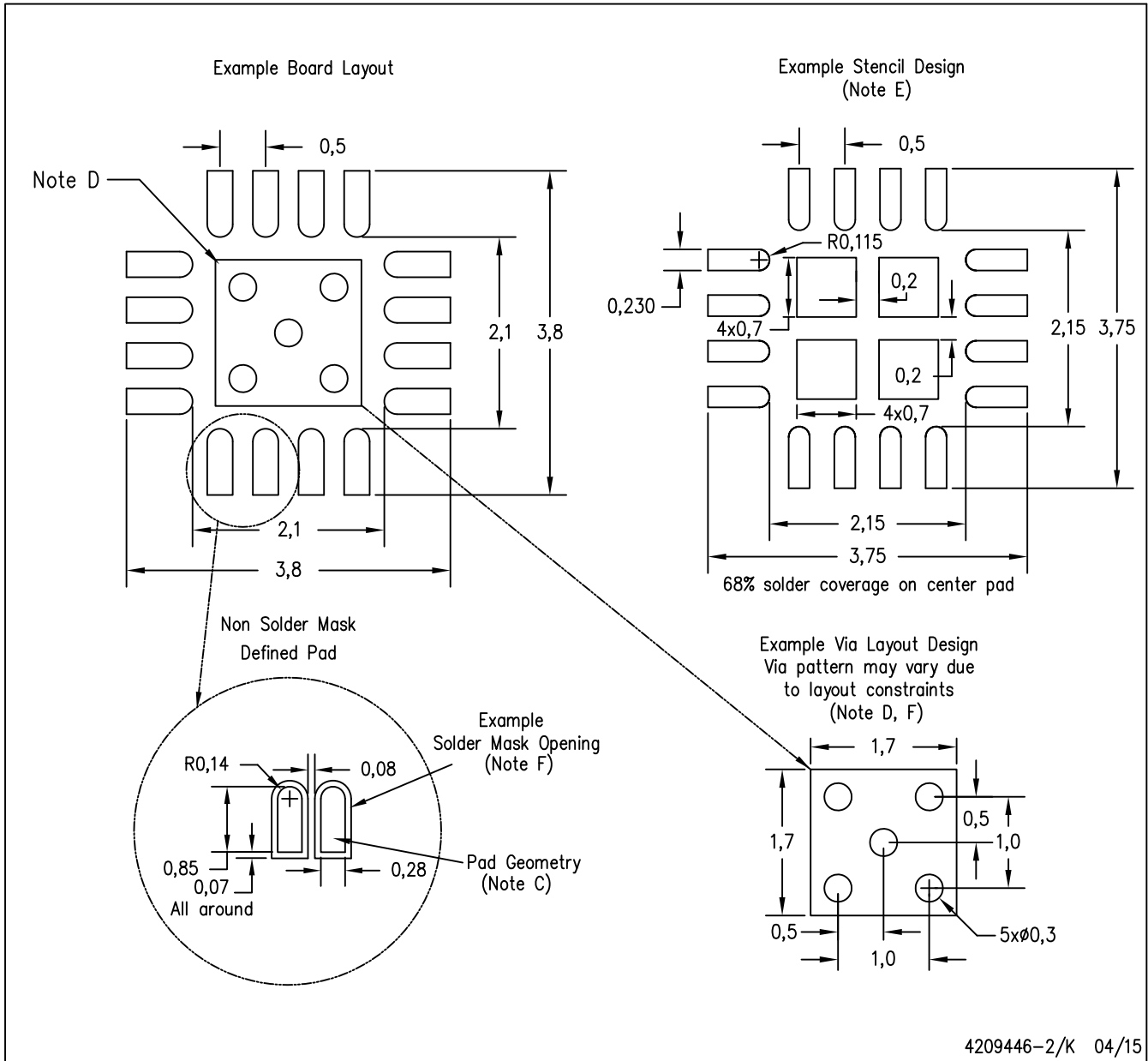

- NOTES:
- A. All linear dimensions are in millimeters.
  - B. This drawing is subject to change without notice.
  - C. Publication IPC-7351 is recommended for alternate designs.
  - D. This package is designed to be soldered to a thermal pad on the board. Refer to Application Note, Quad Flat-Pack Packages, Texas Instruments Literature No. SLUA271, and also the Product Data Sheets for specific thermal information, via requirements, and recommended board layout. These documents are available at [www.ti.com](http://www.ti.com) <<http://www.ti.com>>.
  - E. Laser cutting apertures with trapezoidal walls and also rounding corners will offer better paste release. Customers should contact their board assembly site for stencil design recommendations. Refer to IPC 7525 for stencil design considerations.
  - F. Customers should contact their board fabrication site for minimum solder mask web tolerances between signal pads.

## IMPORTANT NOTICE AND DISCLAIMER

TI PROVIDES TECHNICAL AND RELIABILITY DATA (INCLUDING DATASHEETS), DESIGN RESOURCES (INCLUDING REFERENCE DESIGNS), APPLICATION OR OTHER DESIGN ADVICE, WEB TOOLS, SAFETY INFORMATION, AND OTHER RESOURCES "AS IS" AND WITH ALL FAULTS, AND DISCLAIMS ALL WARRANTIES, EXPRESS AND IMPLIED, INCLUDING WITHOUT LIMITATION ANY IMPLIED WARRANTIES OF MERCHANTABILITY, FITNESS FOR A PARTICULAR PURPOSE OR NON-INFRINGEMENT OF THIRD PARTY INTELLECTUAL PROPERTY RIGHTS.

These resources are intended for skilled developers designing with TI products. You are solely responsible for (1) selecting the appropriate TI products for your application, (2) designing, validating and testing your application, and (3) ensuring your application meets applicable standards, and any other safety, security, or other requirements. These resources are subject to change without notice. TI grants you permission to use these resources only for development of an application that uses the TI products described in the resource. Other reproduction and display of these resources is prohibited. No license is granted to any other TI intellectual property right or to any third party intellectual property right. TI disclaims responsibility for, and you will fully indemnify TI and its representatives against, any claims, damages, costs, losses, and liabilities arising out of your use of these resources.

TI's products are provided subject to TI's Terms of Sale ([www.ti.com/legal/termsofsale.html](http://www.ti.com/legal/termsofsale.html)) or other applicable terms available either on [ti.com](http://ti.com) or provided in conjunction with such TI products. TI's provision of these resources does not expand or otherwise alter TI's applicable warranties or warranty disclaimers for TI products.

Mailing Address: Texas Instruments, Post Office Box 655303, Dallas, Texas 75265  
Copyright © 2019, Texas Instruments Incorporated

## Looking for pricing, stock, or lifecycle information?

Click below to explore more details on WIN SOURCE:

 [View TPS55330RTET on WIN SOURCE](#)

 [Texas Instruments](#) Information

## Optimize Your Supply Chain with WIN SOURCE Solutions

-  Global Sourcing Solution
-  Obsolete Management
-  Cost Control Management
-  Shortage Management
-  Alternative Solution
-  Excess Inventory Management