



# THE DATASHEET OF OPA2171MDCUTEP



## OPA2171-EP 36-V, Single-Supply, SOT553, General-Purpose Operational Amplifiers

### 1 Features

- Supply Range: 2.7 to 36 V,  $\pm 1.35$  V to  $\pm 18$  V
- Low Noise:  $14 \text{ nV}/\sqrt{\text{Hz}}$
- Low Offset Drift:  $\pm 0.3 \text{ } \mu\text{V}/^\circ\text{C}$  (Typ)
- RFI Filtered Inputs
- Input Range Includes the Negative Supply
- Input Range Operates to Positive Supply
- Rail-to-Rail Output
- Gain Bandwidth: 3 MHz
- Low Quiescent Current: 475  $\mu\text{A}$  per Amplifier
- High Common-Mode Rejection: 120 dB (Typ)
- Low-Input Bias Current: 8 pA
- *microPackage*: Dual in VSSOP-8
- **Supports Defense, Aerospace, and Medical Applications:**
  - Controlled Baseline
  - One Assembly/Test Site
  - One Fabrication Site
  - Available in Extended ( $-55^\circ\text{C}$  to  $125^\circ\text{C}$ ) Temperature Range
  - Extended Product Life Cycle
  - Extended Product-Change Notification
  - Product Traceability

#### Unity-Gain Buffer With $R_{\text{ISO}}$ Stability Compensation

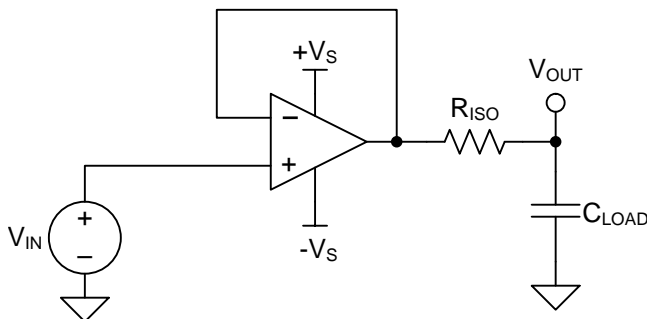

### 2 Applications

- Tracking Amplifier in Power Modules
- Merchant Power Supplies
- Transducer Amplifiers
- Bridge Amplifiers
- Temperature Measurements
- Strain Gauge Amplifiers
- Precision Integrators
- Battery-Powered Instruments
- Test Equipment

### 3 Description

The OPA2171-EP is a 36-V, single-supply, low-noise operational amplifier with the ability to operate on supplies ranging from 2.7 V ( $\pm 1.35$  V) to 36 V ( $\pm 18$  V). These devices are available in micro-packages and offer low offset, drift, and bandwidth with low quiescent current. The single, dual, and quad versions all have identical specifications for maximum design flexibility.

Unlike most operational amplifiers, which are specified at only one supply voltage, the OPA2171-EP is specified from 2.7 to 36 V. Input signals beyond the supply rails do not cause phase reversal. The OPA2171-EP is stable with capacitive loads up to 300 pF. The input can operate 100 mV below the negative rail and within 2 V of the top rail during normal operation. Note that these devices can operate with full rail-to-rail input 100 mV beyond the top rail, but with reduced performance within 2 V of the top rail.

The OPA2171-EP operational amplifier is specified from  $-55^\circ\text{C}$  to  $125^\circ\text{C}$ .

#### Device Information<sup>(1)</sup>

| PART NUMBER | PACKAGE   | BODY SIZE (NOM)   |
|-------------|-----------|-------------------|
| OPA2171-EP  | VSSOP (8) | 2.30 mm x 2.00 mm |

(1) For all available packages, see the orderable addendum at the end of the data sheet.



## Table of Contents

|  |           |  |           |
|--|-----------|--|-----------|
| <b>1 Features</b> .....                        | <b>1</b>  | 7.3 Feature Description.....                                     | <b>14</b> |
| <b>2 Applications</b> .....                    | <b>1</b>  | 7.4 Device Functional Modes.....                                 | <b>15</b> |
| <b>3 Description</b> .....                     | <b>1</b>  | <b>8 Application and Implementation</b> .....                    | <b>16</b> |
| <b>4 Revision History</b> .....                | <b>2</b>  | 8.1 Application Information.....                                 | <b>16</b> |
| <b>5 Pin Configuration and Functions</b> ..... | <b>3</b>  | 8.2 Typical Application .....                                    | <b>17</b> |
| <b>6 Specifications</b> .....                  | <b>4</b>  | <b>9 Power Supply Recommendations</b> .....                      | <b>19</b> |
| 6.1 Absolute Maximum Ratings .....             | <b>4</b>  | <b>10 Layout</b> .....   | <b>20</b> |
| 6.2 ESD Ratings.....                           | <b>4</b>  | 10.1 Layout Guidelines .....                                     | <b>20</b> |
| 6.3 Recommended Operating Conditions.....      | <b>4</b>  | 10.2 Layout Example .....  | <b>20</b> |
| 6.4 Thermal Information .....                  | <b>4</b>  | <b>11 Device and Documentation Support</b> .....                 | <b>21</b> |
| 6.5 Electrical Characteristics.....            | <b>5</b>  | 11.1 Community Resources.....                                    | <b>21</b> |
| 6.6 Typical Characteristics.....               | <b>7</b>  | 11.2 Trademarks .....  | <b>21</b> |
| <b>7 Detailed Description</b> .....            | <b>14</b> | 11.3 Electrostatic Discharge Caution.....                        | <b>21</b> |
| 7.1 Overview .....                             | <b>14</b> | 11.4 Glossary .....  | <b>21</b> |
| 7.2 Functional Block Diagram .....             | <b>14</b> | <b>12 Mechanical, Packaging, and Orderable Information</b> ..... | <b>21</b> |

## 4 Revision History

| DATE           | REVISION | NOTES            |
|----------------|----------|------------------|
| September 2015 | *        | Initial release. |

## 5 Pin Configuration and Functions

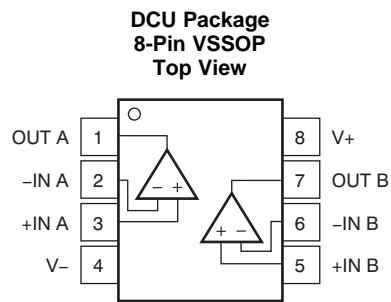

**Pin Functions**

| PIN   |     | I/O | DESCRIPTION                     |
|-------|-----|-----|---------------------------------|
| NAME  | NO. |     |                                 |
| +IN A | 3   | I   | Noninverting input, channel A   |
| +IN B | 5   | I   | Noninverting input, channel B   |
| -IN A | 2   | I   | Inverting input, channel A      |
| -IN B | 6   | I   | Inverting input, channel B      |
| OUT A | 1   | O   | Output, channel A               |
| OUT B | 7   | O   | Output, channel B               |
| V+    | 8   | —   | Positive (highest) power supply |
| V-    | 4   | —   | Negative (lowest) power supply  |

## 6 Specifications

### 6.1 Absolute Maximum Ratings

over operating free-air temperature range, unless otherwise noted<sup>(1)</sup>

|                                       |         | MIN        | MAX        | UNIT |
|---------------------------------------|---------|------------|------------|------|
| Supply voltage                        |         | ±20        |            | V    |
| Signal input pins                     | Voltage | (V-) - 0.5 | (V+) + 0.5 | V    |
|                                       | Current | -10        | 10         | mA   |
| Output short circuit <sup>(2)</sup>   |         | Continuous |            |      |
| Junction temperature                  |         | 150        |            | °C   |
| Storage temperature, T <sub>stg</sub> |         | -65        | 150        | °C   |

- (1) Stresses beyond those listed under *Absolute Maximum Ratings* may cause permanent damage to the device. These are stress ratings only, which do not imply functional operation of the device at these or any other conditions beyond those indicated under *Recommended Operating Conditions*. Exposure to absolute-maximum-rated conditions for extended periods may affect device reliability.
- (2) Short-circuit to ground, one amplifier per package.

### 6.2 ESD Ratings

|                    |                         | VALUE  | UNIT  |
|--------------------|-------------------------|--|-------|
| V <sub>(ESD)</sub> | Electrostatic discharge | Human-body model (HBM), per ANSI/ESDA/JEDEC JS-001 <sup>(1)</sup>              | ±4000 |
|                    |                         | Charged-device model (CDM), per JEDEC specification JESD22-C101 <sup>(2)</sup> | ±750  |

- (1) JEDEC document JEP155 states that 500-V HBM allows safe manufacturing with a standard ESD control process.
- (2) JEDEC document JEP157 states that 250-V CDM allows safe manufacturing with a standard ESD control process.

### 6.3 Recommended Operating Conditions

over operating free-air temperature range (unless otherwise noted)

|                                       | MIN         | NOM | MAX      | UNIT |
|---------------------------------------|-------------|-----|----------|------|
| Supply voltage (V+ - V-)              | 4.5 (±2.25) |     | 36 (±18) | V    |
| Operating temperature, T <sub>j</sub> | -55         |     | 125      | °C   |

### 6.4 Thermal Information

| THERMAL METRIC <sup>(1)</sup> |  | OPA2171-EP  | UNIT |
|-------------------------------|--|-------------|------|
|                               |  | DCU (VSSOP) |      |
|                               |  | 8 PINS      |      |
| R <sub>θJA</sub>              | Junction-to-ambient thermal resistance       | 175.2       | °C/W |
| R <sub>θJC(top)</sub>         | Junction-to-case(top) thermal resistance     | 74.9        | °C/W |
| R <sub>θJB</sub>              | Junction-to-board thermal resistance         | 22.2        | °C/W |
| ψ <sub>JT</sub>               | Junction-to-top characterization parameter   | 1.6         | °C/W |
| ψ <sub>JB</sub>               | Junction-to-board characterization parameter | 22.8        | °C/W |
| R <sub>θJC(bot)</sub>         | Junction-to-case(bottom) thermal resistance  | N/A         | °C/W |

- (1) For more information about traditional and new thermal metrics, see the *Semiconductor and IC Package Thermal Metrics* application report, [SPRA953](#).

## 6.5 Electrical Characteristics

at  $T_J = 25^\circ\text{C}$ ,  $V_S = 2.7$  to  $36\text{ V}$ ,  $V_{CM} = V_{OUT} = V_S / 2$ , and  $R_{LOAD} = 10\text{ k}\Omega$  connected to  $V_S / 2$ , unless otherwise noted.

| PARAMETER                                | TEST CONDITIONS                                  | MIN   | TYP   | MAX                 | UNIT                                 |
|--|--|---|---|---------------------|--------------------------------------|
| <b>OFFSET VOLTAGE</b>                    |  |   |   |                     |                                      |
| Input offset voltage                     | $V_{OS}$   |   | 0.25  | $\pm 1.8$           | mV                                   |
| Over temperature                         | $T_J = -55^\circ\text{C}$ to $125^\circ\text{C}$ |   | 0.3   | $\pm 2$             | mV                                   |
| Drift                                    | $dV_{OS}/dT$                                     | $T_J = -55^\circ\text{C}$ to $125^\circ\text{C}$  | 0.3   |                     | $\mu\text{V}/^\circ\text{C}$         |
| vs power supply                          | PSRR   | $V_S = 4$ to $36\text{ V}$ , $T_A = -55^\circ\text{C}$ to $125^\circ\text{C}$   | 1   | $\pm 5$             | $\mu\text{V}/\text{V}$               |
| Channel separation, dc                   | dc   |   | 5   |                     | $\mu\text{V}/\text{V}$               |
| <b>INPUT BIAS CURRENT</b>                |  |   |   |                     |                                      |
| Input bias current                       | $I_B$  |   | $\pm 8$                                     | $\pm 15$            | pA                                   |
| Over temperature                         | $T_J = -55^\circ\text{C}$ to $125^\circ\text{C}$ |   |   | $\pm 4$             | nA                                   |
| Input offset current                     | $I_{OS}$   |   | $\pm 4$                                     |                     | pA                                   |
| Over temperature                         | $T_J = -55^\circ\text{C}$ to $125^\circ\text{C}$ |   |   | $\pm 4$             | nA                                   |
| <b>NOISE</b>                             |  |   |   |                     |                                      |
| Input voltage noise                      | $f = 0.1$ to $10\text{ Hz}$                      |   | 3   |                     | $\mu\text{V}_{PP}$                   |
| Input voltage noise density              | $e_n$  | $f = 100\text{ Hz}$   | 25  |                     | $\text{nV}/\sqrt{\text{Hz}}$         |
|  |  | $f = 1\text{ kHz}$  | 14  |                     | $\text{nV}/\sqrt{\text{Hz}}$         |
| <b>INPUT VOLTAGE</b>                     |  |   |   |                     |                                      |
| Common-mode voltage range <sup>(1)</sup> | $V_{CM}$   | $(V-) - 0.1\text{ V}$   |   | $(V+) - 2\text{ V}$ | V                                    |
| Common-mode rejection ratio              | CMRR   | $V_S = \pm 2\text{ V}$ , $(V-) - 0.1\text{ V} < V_{CM} < (V+) - 2\text{ V}$ ,<br>$T_J = -55^\circ\text{C}$ to $125^\circ\text{C}$   | 87  | 104                 | dB                                   |
|  |  | $V_S = \pm 18\text{ V}$ , $(V-) - 0.1\text{ V} < V_{CM} < (V+) - 2\text{ V}$ ,<br>$T_J = -55^\circ\text{C}$ to $125^\circ\text{C}$  | 104   | 120                 | dB                                   |
| <b>INPUT IMPEDANCE</b>                   |  |   |   |                     |                                      |
| Differential                             |  |   | $100 \parallel 3$                           |                     | $\text{M}\Omega \parallel \text{pF}$ |
| Common-mode                              |  |   | $6 \parallel 3$                             |                     | $10^{12}\Omega \parallel \text{pF}$  |
| <b>OPEN-LOOP GAIN</b>                    |  |   |   |                     |                                      |
| Open-loop voltage gain                   | $A_{OL}$   | $V_S = 4$ to $36\text{ V}$ , $(V-) + 0.35\text{ V} < V_O < (V+) - 0.35\text{ V}$ , $T_J = -55^\circ\text{C}$ to $125^\circ\text{C}$ | 110   | 130                 | dB                                   |
| <b>FREQUENCY RESPONSE</b>                |  |   |   |                     |                                      |
| Gain bandwidth product                   | GBP  |   | 3.0   |                     | MHz                                  |
| Slew rate                                | SR   | $G = +1$  | 1.5   |                     | $\text{V}/\mu\text{s}$               |
| Settling time                            | $t_s$  | To 0.1%, $V_S = \pm 18\text{ V}$ , $G = +1$ , 10-V step   | 6   |                     | $\mu\text{s}$                        |
|  |  | To 0.01% (12 bit), $V_S = \pm 18\text{ V}$ , $G = +1$ , 10-V step   | 10  |                     | $\mu\text{s}$                        |
| Overload recovery time                   |  | $V_{IN} \times \text{Gain} > V_S$   | 2   |                     | $\mu\text{s}$                        |
| Total harmonic distortion + noise        | THD+N  | $G = +1$ , $f = 1\text{ kHz}$ , $V_O = 3V_{RMS}$  | 0.0002%                                     |                     |                                      |
| <b>OUTPUT</b>                            |  |   |   |                     |                                      |
| Voltage output swing from rail           | $V_O$  | $V_S = 5\text{ V}$ , $R_L = 10\text{ k}\Omega$  | 30  |                     | mV                                   |
| Over temperature                         |  | $R_L = 10\text{ k}\Omega$ , $A_{OL} \geq 110\text{ dB}$ ,<br>$T_J = -55^\circ\text{C}$ to $125^\circ\text{C}$                       | $(V-) + 0.35$                               | $(V+) - 0.35$       | V                                    |
| Short-circuit current                    | $I_{SC}$   |   | +25/-35                                     |                     | mA                                   |
| Capacitive load drive                    | $C_{LOAD}$                                       |   | See <a href="#">Typical Characteristics</a> |                     | pF                                   |
| Open-loop output resistance              | $R_O$  | $f = 1\text{ MHz}$ , $I_O = 0\text{ A}$   | 150   |                     | $\Omega$                             |

(1) The input range can be extended beyond  $(V+) - 2\text{ V}$  up to  $V+$ . See [Typical Characteristics](#) and [Application and Implementation](#) for additional information.

**Electrical Characteristics (continued)**

 at  $T_J = 25^\circ\text{C}$ ,  $V_S = 2.7$  to  $36\text{ V}$ ,  $V_{CM} = V_{OUT} = V_S / 2$ , and  $R_{LOAD} = 10\text{ k}\Omega$  connected to  $V_S / 2$ , unless otherwise noted.

| PARAMETER                       |       | TEST CONDITIONS   | MIN | TYP | MAX | UNIT             |
|---------------------------------|-------|---|-----|-----|-----|------------------|
| <b>POWER SUPPLY</b>             |       |   |     |     |     |                  |
| Specified voltage range         | $V_S$ |   | 2.7 |     | 36  | V                |
| Quiescent current per amplifier | $I_Q$ | $I_O = 0\text{ A}$  |     | 475 | 595 | $\mu\text{A}$    |
| Over temperature                |       | $I_O = 0\text{ A}$ , $T_J = -55^\circ\text{C}$ to $125^\circ\text{C}$ |     |     | 650 | $\mu\text{A}$    |
| <b>TEMPERATURE</b>              |       |   |     |     |     |                  |
| Operating temperature           | $T_J$ |   | -55 |     | 125 | $^\circ\text{C}$ |

## 6.6 Typical Characteristics

**Table 1. Characteristic Performance Measurements**

| DESCRIPTION  | FIGURE  |
|--|---|
| Offset Voltage Production Distribution                         | <a href="#">Figure 1</a>                              |
| Offset Voltage Drift Distribution                              | <a href="#">Figure 2</a>                              |
| Offset Voltage vs Temperature                                  | <a href="#">Figure 3</a>                              |
| Offset Voltage vs Common-Mode Voltage                          | <a href="#">Figure 4</a>                              |
| Offset Voltage vs Common-Mode Voltage (Upper Stage)            | <a href="#">Figure 5</a>                              |
| Offset Voltage vs Power Supply                                 | <a href="#">Figure 6</a>                              |
| $I_B$ and $I_{OS}$ vs Common-Mode Voltage                      | <a href="#">Figure 7</a>                              |
| Input Bias Current vs Temperature                              | <a href="#">Figure 8</a>                              |
| Output Voltage Swing vs Output Current (Maximum Supply)        | <a href="#">Figure 9</a>                              |
| CMRR and PSRR vs Frequency (Referred-to Input)                 | <a href="#">Figure 10</a>                             |
| CMRR vs Temperature  | <a href="#">Figure 11</a>                             |
| PSRR vs Temperature  | <a href="#">Figure 12</a>                             |
| 0.1-Hz to 10-Hz Noise  | <a href="#">Figure 13</a>                             |
| Input Voltage Noise Spectral Density vs Frequency              | <a href="#">Figure 14</a>                             |
| THD+N Ratio vs Frequency                                       | <a href="#">Figure 15</a>                             |
| THD+N vs Output Amplitude                                      | <a href="#">Figure 16</a>                             |
| Quiescent Current vs Temperature                               | <a href="#">Figure 17</a>                             |
| Quiescent Current vs Supply Voltage                            | <a href="#">Figure 18</a>                             |
| Open-Loop Gain and Phase vs Frequency                          | <a href="#">Figure 19</a>                             |
| Closed-Loop Gain vs Frequency                                  | <a href="#">Figure 20</a>                             |
| Open-Loop Gain vs Temperature                                  | <a href="#">Figure 21</a>                             |
| Open-Loop Output Impedance vs Frequency                        | <a href="#">Figure 22</a>                             |
| Small-Signal Overshoot vs Capacitive Load (100-mV Output Step) | <a href="#">Figure 23</a> , <a href="#">Figure 24</a> |
| No Phase Reversal  | <a href="#">Figure 25</a>                             |
| Positive Overload Recovery                                     | <a href="#">Figure 26</a>                             |
| Negative Overload Recovery                                     | <a href="#">Figure 27</a>                             |
| Small-Signal Step Response (100 mV)                            | <a href="#">Figure 28</a> , <a href="#">Figure 29</a> |
| Large-Signal Step Response                                     | <a href="#">Figure 30</a> , <a href="#">Figure 31</a> |
| Large-Signal Settling Time (10-V Positive Step)                | <a href="#">Figure 32</a>                             |
| Large-Signal Settling Time (10-V Negative Step)                | <a href="#">Figure 33</a>                             |
| Short-Circuit Current vs Temperature                           | <a href="#">Figure 34</a>                             |
| Maximum Output Voltage vs Frequency                            | <a href="#">Figure 35</a>                             |
| Channel Separation vs Frequency                                | <a href="#">Figure 36</a>                             |

$V_S = \pm 18\text{ V}$ ,  $V_{CM} = V_S / 2$ ,  $R_{LOAD} = 10\text{ k}\Omega$  connected to  $V_S / 2$ , and  $C_L = 100\text{ pF}$ , unless otherwise noted.

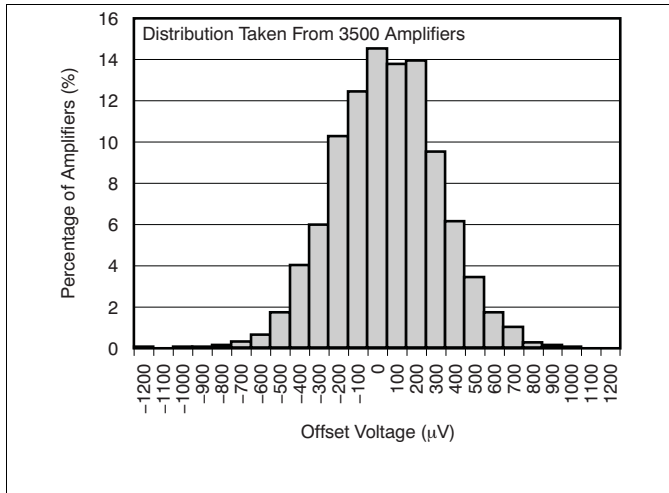

Figure 1. Offset Voltage Production Distribution

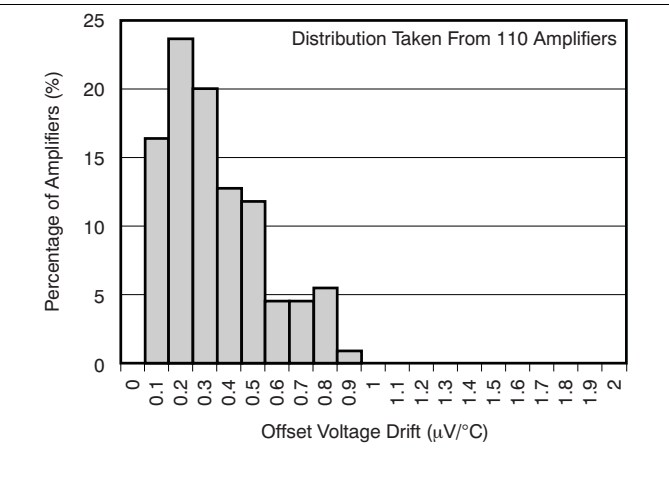

Figure 2. Offset Voltage Drift Distribution

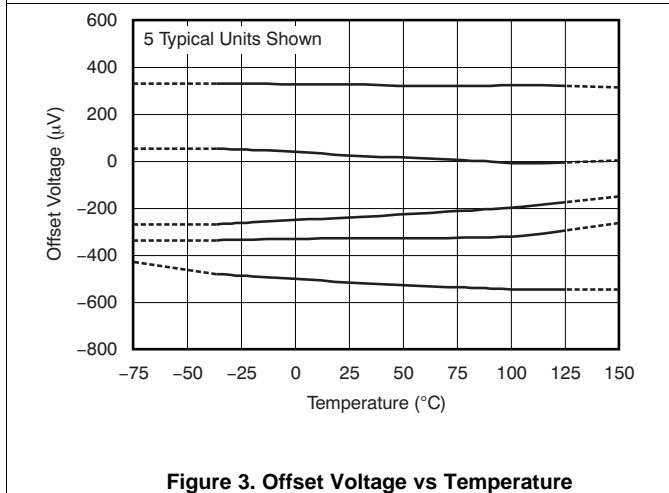

Figure 3. Offset Voltage vs Temperature

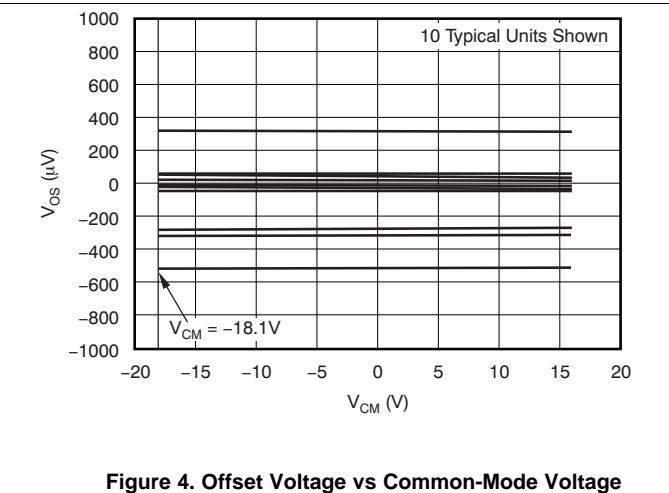

Figure 4. Offset Voltage vs Common-Mode Voltage

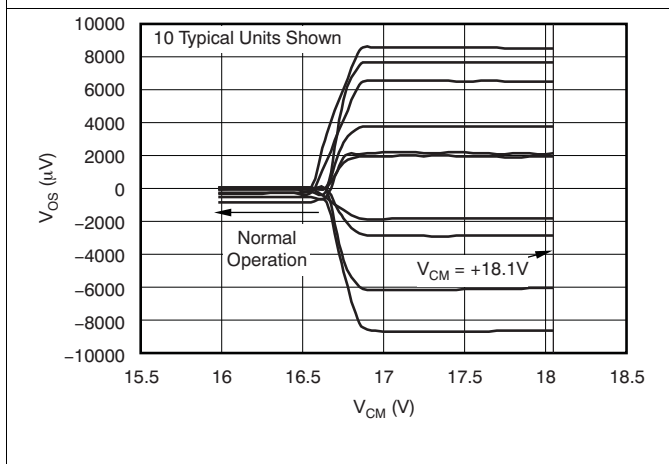

Figure 5. Offset Voltage vs Common-Mode Voltage (Upper Stage)

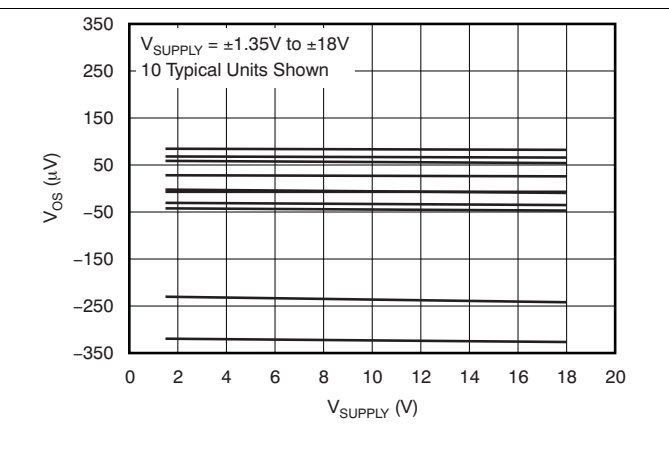

Figure 6. Offset Voltage vs Power Supply

$V_S = \pm 18\text{ V}$ ,  $V_{CM} = V_S / 2$ ,  $R_{LOAD} = 10\text{ k}\Omega$  connected to  $V_S / 2$ , and  $C_L = 100\text{ pF}$ , unless otherwise noted.

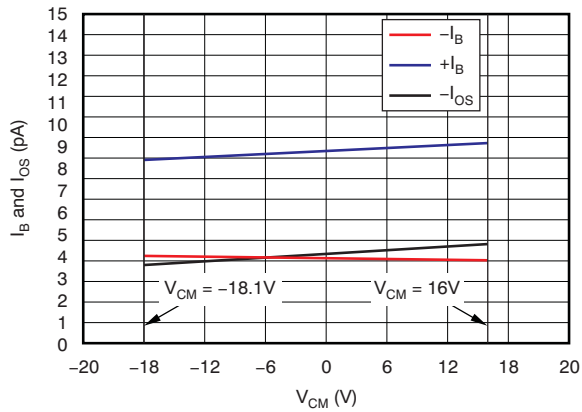

Figure 7.  $I_B$  and  $I_{OS}$  vs Common-Mode Voltage

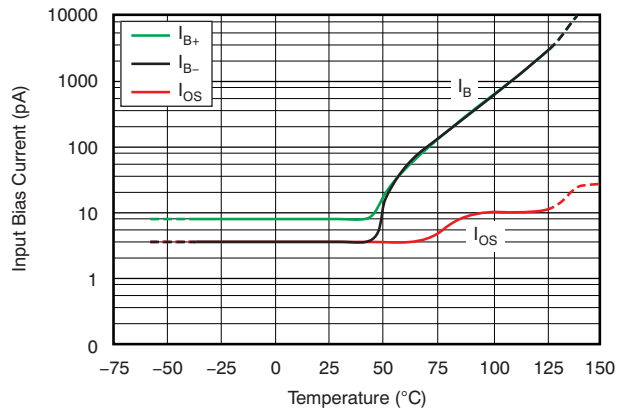

Figure 8. Input Bias Current vs Temperature

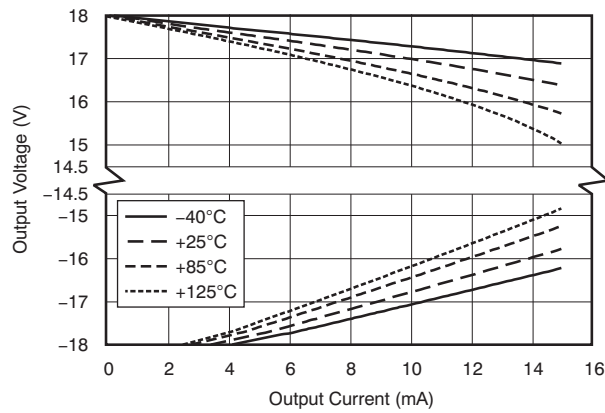

Figure 9. Output Voltage Swing vs Output Current (Maximum Supply)

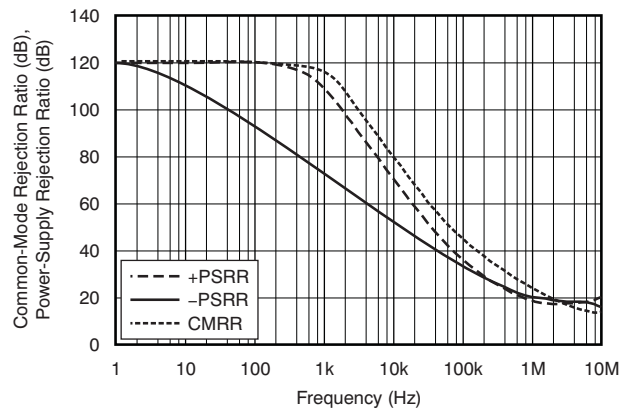

Figure 10. CMRR and PSRR vs Frequency (Referred-to Input)

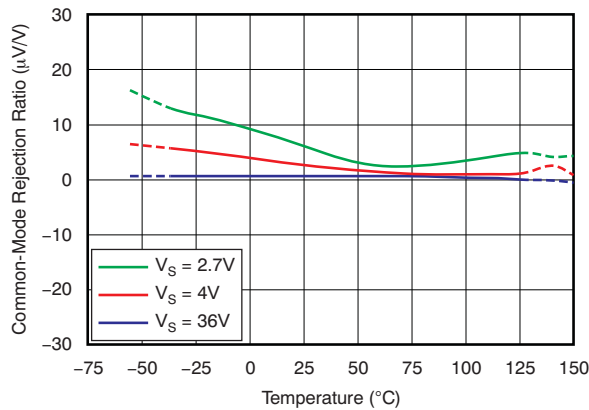

Figure 11. CMRR vs Temperature

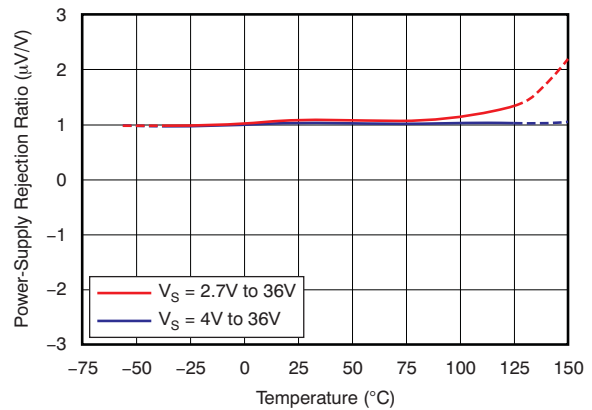

Figure 12. PSRR vs Temperature

$V_S = \pm 18\text{ V}$ ,  $V_{CM} = V_S / 2$ ,  $R_{LOAD} = 10\text{ k}\Omega$  connected to  $V_S / 2$ , and  $C_L = 100\text{ pF}$ , unless otherwise noted.

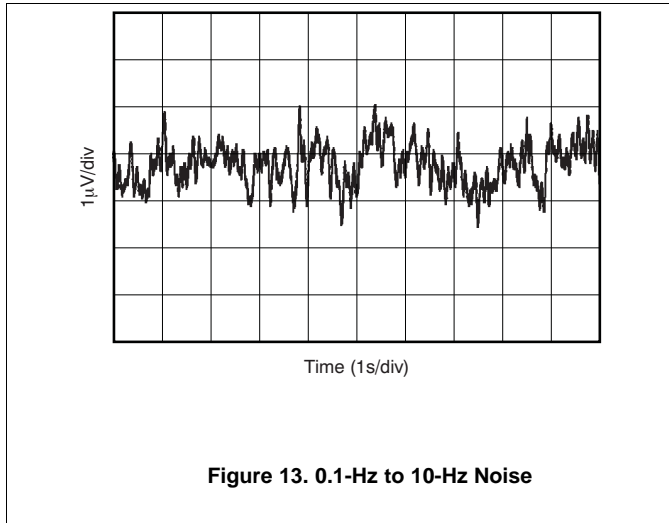

Figure 13. 0.1-Hz to 10-Hz Noise

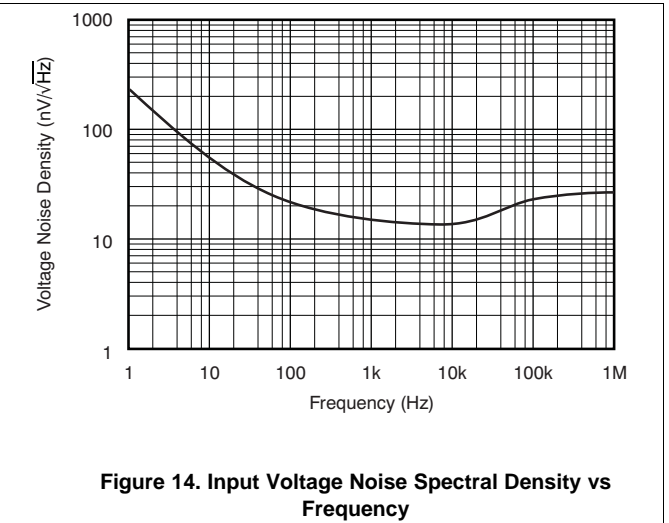

Figure 14. Input Voltage Noise Spectral Density vs Frequency

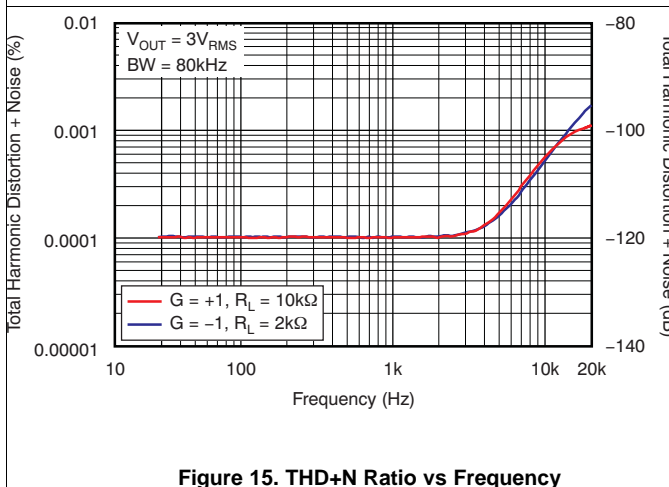

Figure 15. THD+N Ratio vs Frequency

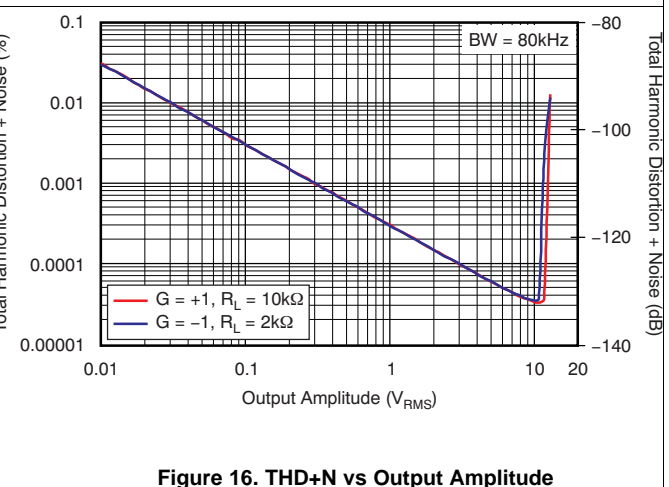

Figure 16. THD+N vs Output Amplitude

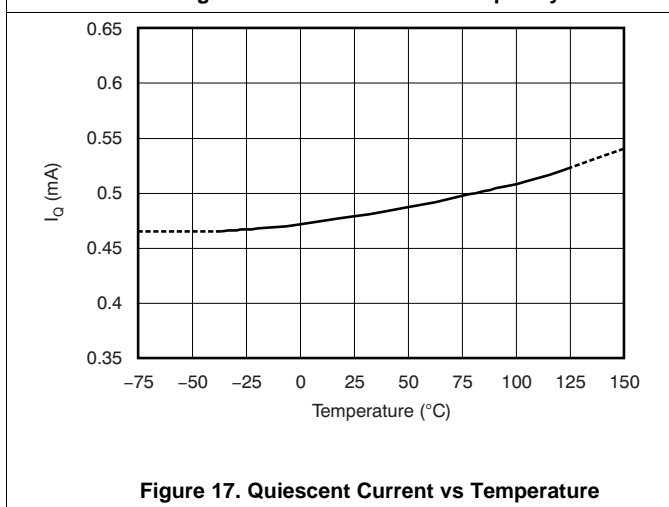

Figure 17. Quiescent Current vs Temperature

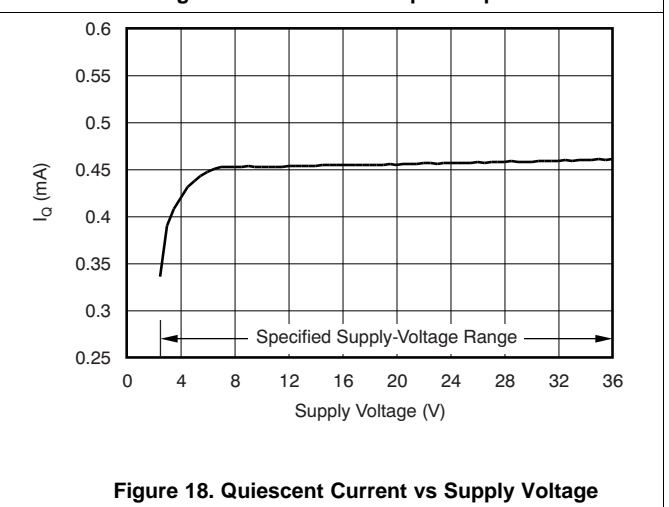

Figure 18. Quiescent Current vs Supply Voltage

$V_S = \pm 18\text{ V}$ ,  $V_{CM} = V_S / 2$ ,  $R_{LOAD} = 10\text{ k}\Omega$  connected to  $V_S / 2$ , and  $C_L = 100\text{ pF}$ , unless otherwise noted.

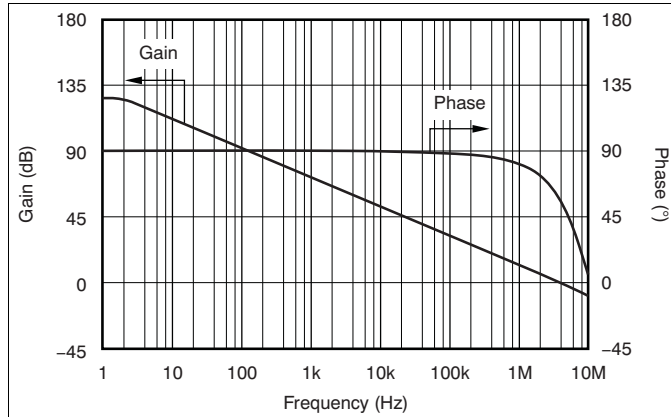

Figure 19. Open-Loop Gain and Phase vs Frequency

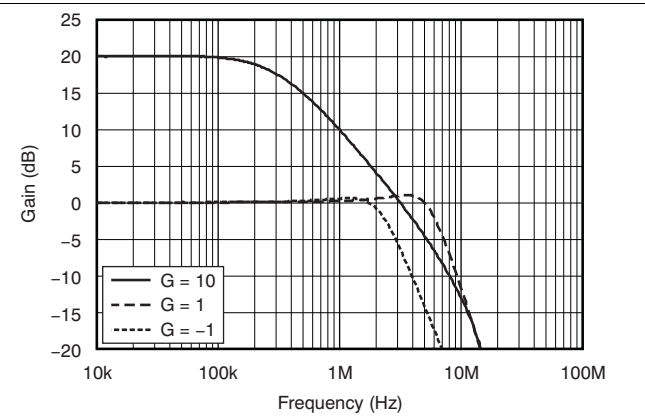

Figure 20. Closed-Loop Gain vs Frequency

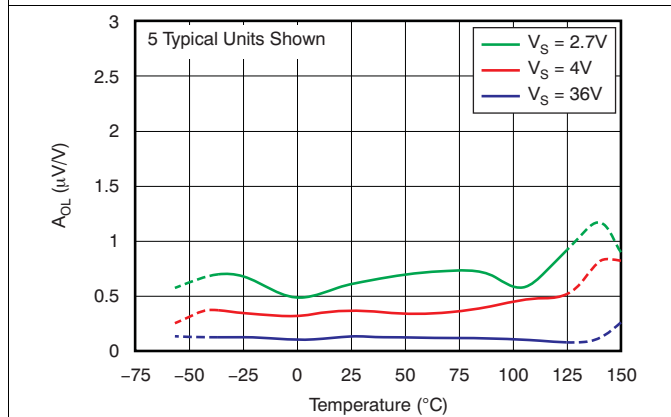

Figure 21. Open-Loop Gain vs Temperature

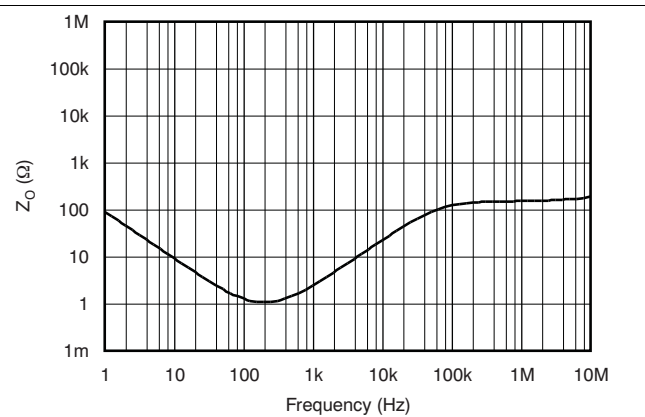

Figure 22. Open-Loop Output Impedance vs Frequency

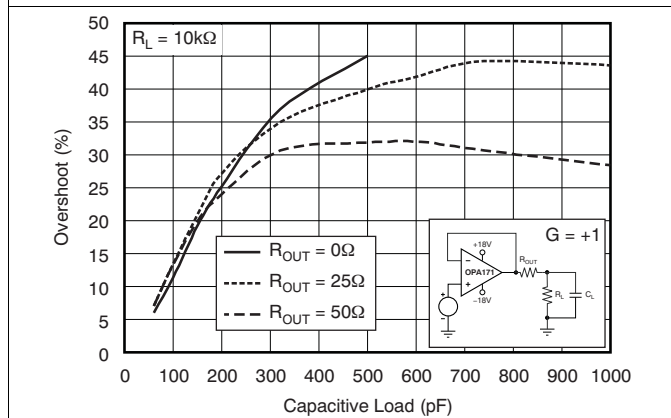

Figure 23. Small-Signal Overshoot vs Capacitive Load (100-mV Output Step)

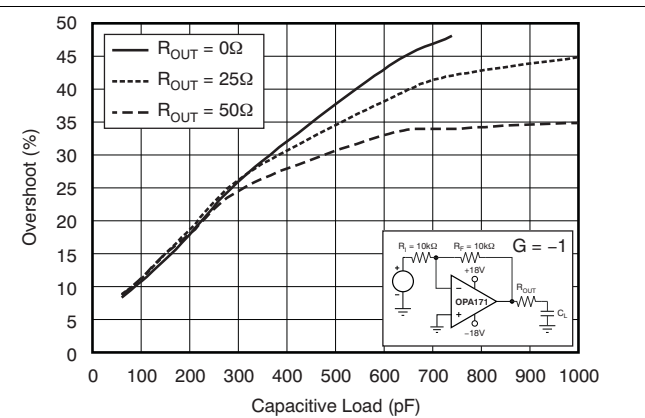

Figure 24. Small-Signal Overshoot vs Capacitive Load (100-mV Output Step)

$V_S = \pm 18\text{ V}$ ,  $V_{CM} = V_S / 2$ ,  $R_{LOAD} = 10\text{ k}\Omega$  connected to  $V_S / 2$ , and  $C_L = 100\text{ pF}$ , unless otherwise noted.

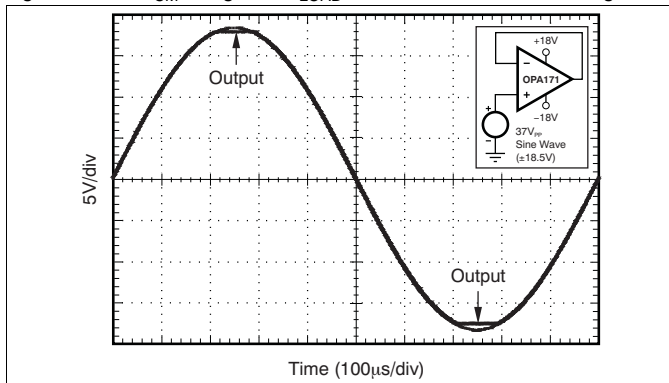

Figure 25. No Phase Reversal

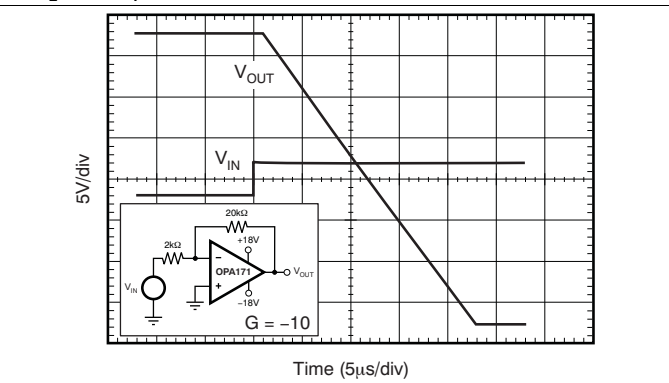

Figure 26. Positive Overload Recovery

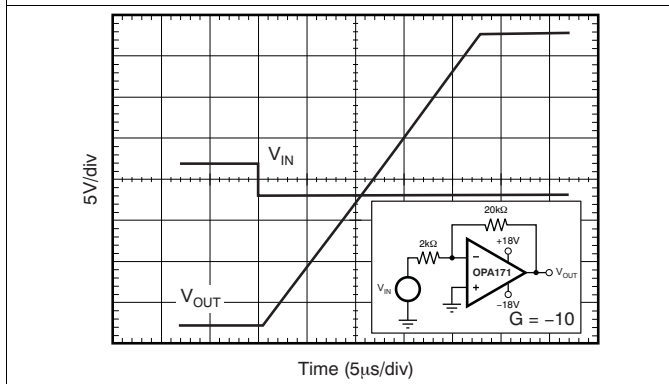

Figure 27. Negative Overload Recovery

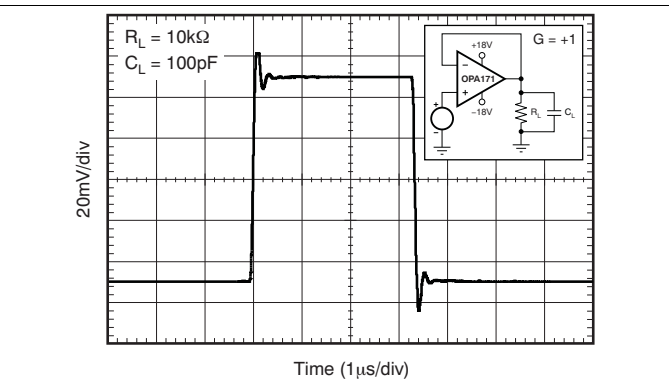

Figure 28. Small-Signal Step Response (100 mV)

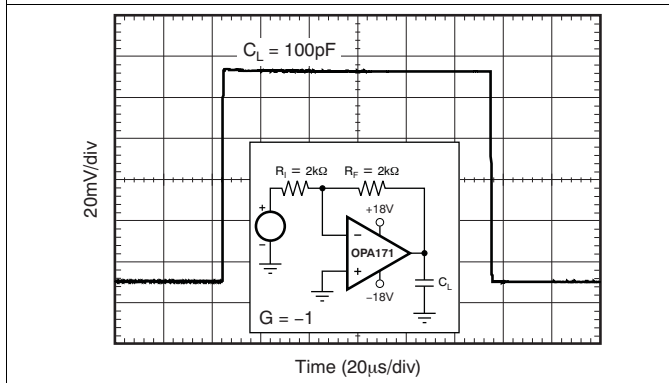

Figure 29. Small-Signal Step Response (100 mV)

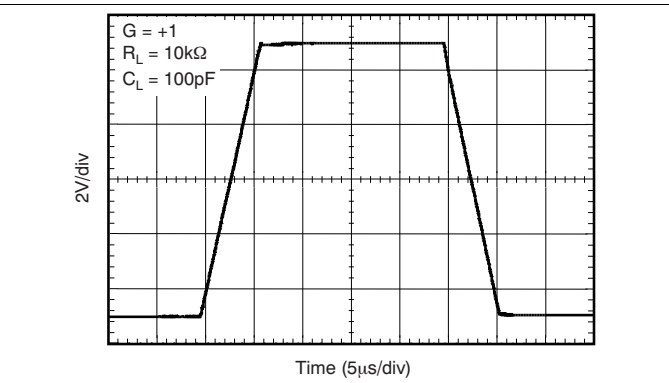
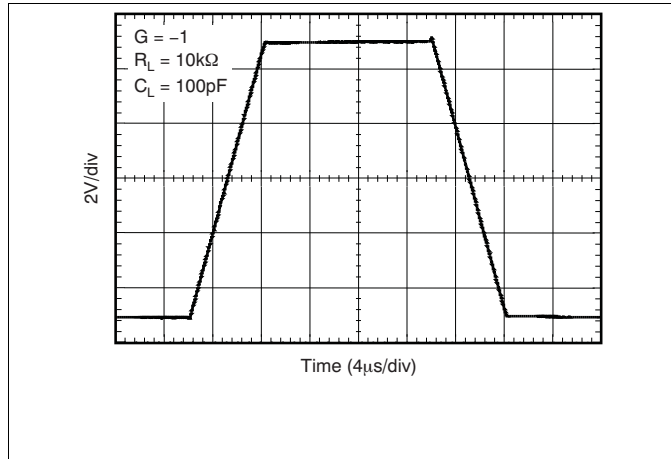
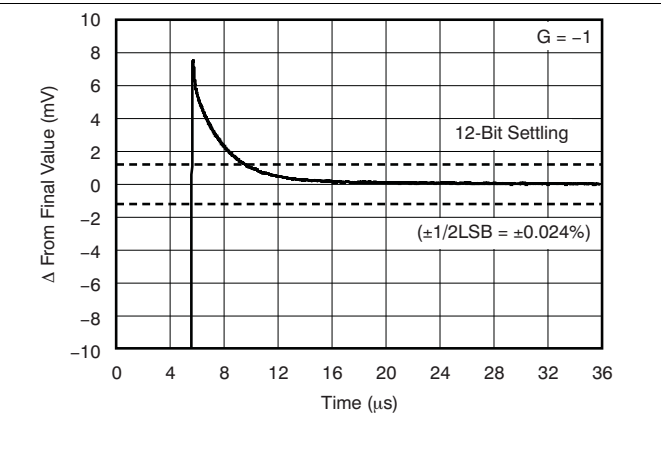

Figure 30. Large-Signal Step Response

$V_S = \pm 18\text{ V}$ ,  $V_{CM} = V_S / 2$ ,  $R_{LOAD} = 10\text{ k}\Omega$  connected to  $V_S / 2$ , and  $C_L = 100\text{ pF}$ , unless otherwise noted.



**Figure 31. Large-Signal Step Response**



**Figure 32. Large-Signal Settling Time (10-V Positive Step)**

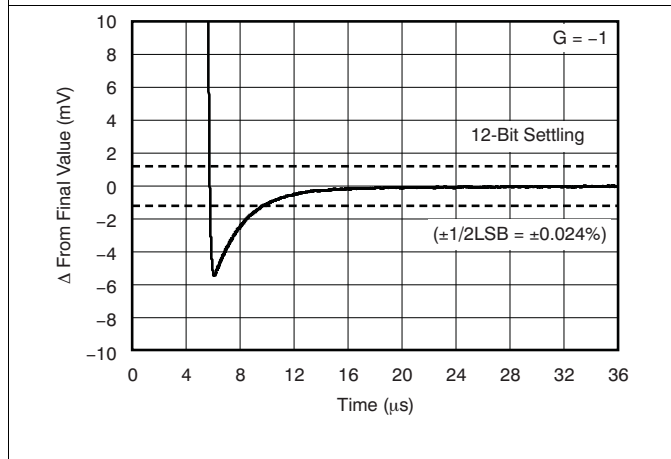

**Figure 33. Large-Signal Settling Time (10-V Negative Step)**

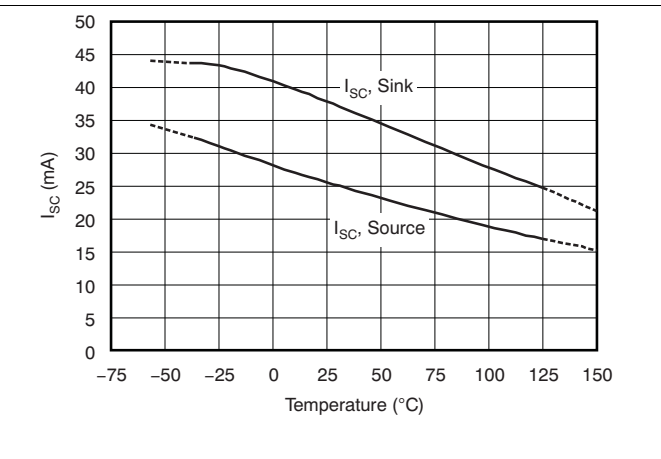

**Figure 34. Short-Circuit Current vs Temperature**

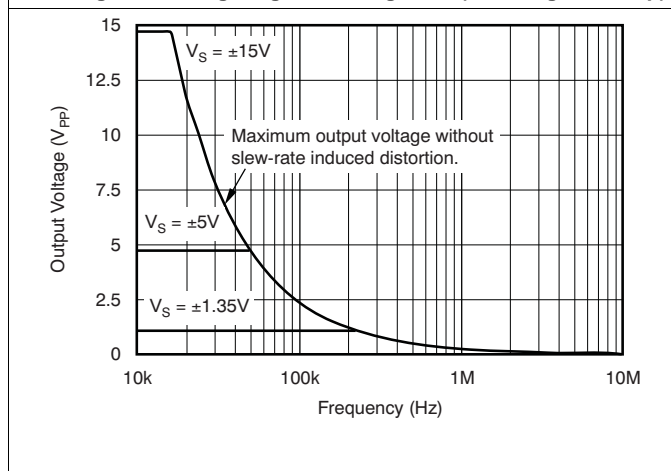

**Figure 35. Maximum Output Voltage vs Frequency**

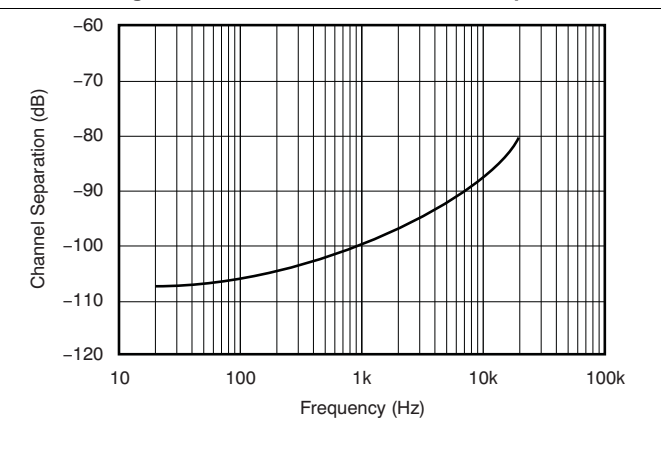

**Figure 36. Channel Separation vs Frequency**

## 7 Detailed Description

### 7.1 Overview

The OPA2171-EP operational amplifier provides high overall performance, making it ideal for many general-purpose applications. The excellent offset drift of only  $2 \mu\text{V}/^\circ\text{C}$  provides excellent stability over the entire temperature range. In addition, the device offers very good overall performance with high CMRR, PSRR, and  $A_{OL}$ . As with all amplifiers, applications with noisy or high-impedance power supplies require decoupling capacitors close to the device pins. In most cases,  $0.1\text{-}\mu\text{F}$  capacitors are adequate.

### 7.2 Functional Block Diagram

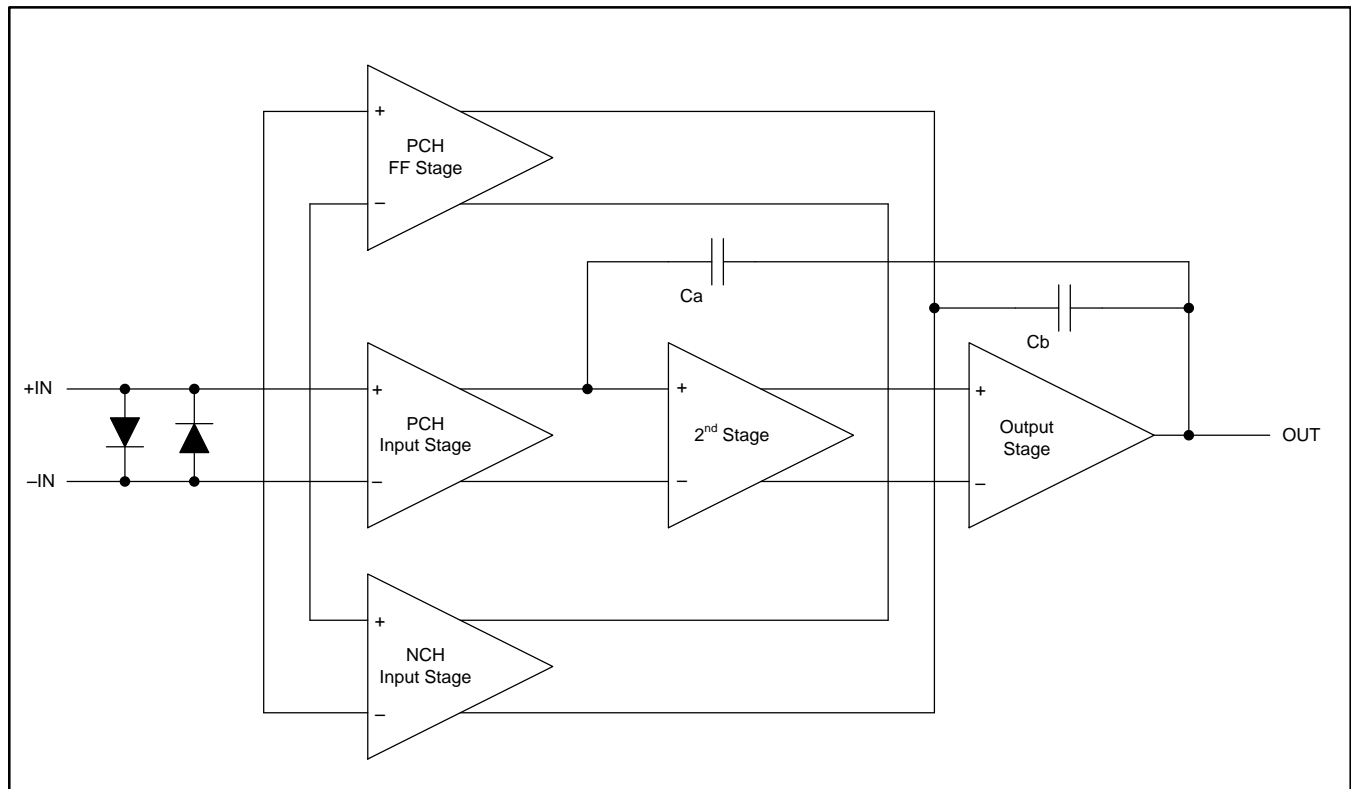

### 7.3 Feature Description

#### 7.3.1 Operating Characteristics

The OPA2171-EP amplifier is specified for operation from 2.7 to 36 V ( $\pm 1.35$  to  $\pm 18$  V). Many of the specifications apply from  $-55^\circ\text{C}$  to  $125^\circ\text{C}$ . Parameters that can exhibit significant variance with regard to operating voltage or temperature are presented in [Typical Characteristics](#).

#### 7.3.2 Phase-Reversal Protection

The OPA2171-EP has an internal phase-reversal protection. Many operational amplifiers exhibit a phase reversal when the input is driven beyond its linear common-mode range. This condition is most often encountered in noninverting circuits when the input is driven beyond the specified common-mode voltage range, causing the output to reverse into the opposite rail. The input of the OPA2171-EP prevents phase reversal with excessive common-mode voltage. Instead, the output limits into the appropriate rail. [Figure 37](#) shows this performance.

## Feature Description (continued)

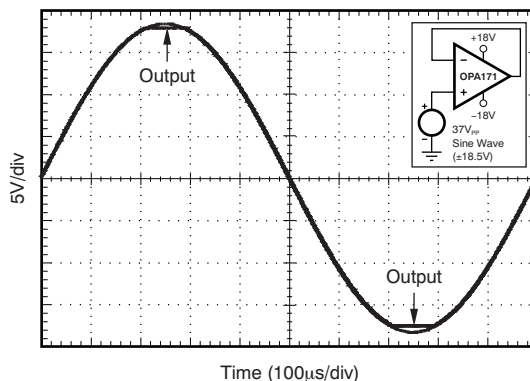

Figure 37. No Phase Reversal

## 7.4 Device Functional Modes

### 7.4.1 Common-Mode Voltage Range

The input common-mode voltage range of the OPA2171-EP extends 100 mV below the negative rail and within 2 V of the top rail for normal operation.

This device can operate with full rail-to-rail input 100 mV beyond the top rail, but with reduced performance within 2 V of the top rail. [Table 2](#) summarizes the typical performance in this range.

Table 2. Typical Performance Range

| PARAMETER                        | MIN             | TYP       | MAX               | UNIT         |
|----------------------------------|-----------------|-----------|-------------------|--------------|
| <b>Input Common-Mode Voltage</b> | <b>(V+) – 2</b> |           | <b>(V+) + 0.1</b> | <b>V</b>     |
| Offset voltage                   |                 | 7         |                   | mV           |
| <b>vs Temperature</b>            |                 | <b>12</b> |                   | <b>µV/°C</b> |
| Common-mode rejection            |                 | 65        |                   | dB           |
| Open-loop gain                   |                 | 60        |                   | dB           |
| GBW                              |                 | 0.7       |                   | MHz          |
| Slew rate                        |                 | 0.7       |                   | V/µs         |
| Noise at $f = 1\text{kHz}$       |                 | 30        |                   | nV/√Hz       |

## 8 Application and Implementation

### NOTE

Information in the following applications sections is not part of the TI component specification, and TI does not warrant its accuracy or completeness. TI's customers are responsible for determining suitability of components for their purposes. Customers should validate and test their design implementation to confirm system functionality.

### 8.1 Application Information

#### 8.1.1 Electrical Overstress

Designers often ask about the capability of an operational amplifier to withstand electrical overstress. These questions tend to focus on the device inputs, but may involve the supply voltage pins or even the output pin. Each of these different pin functions have electrical stress limits determined by the voltage breakdown characteristics of the particular semiconductor fabrication process and specific circuits connected to the pin. Additionally, internal electrostatic discharge (ESD) protection is built into these circuits to protect them from accidental ESD events both before and during product assembly.

These ESD protection diodes also provide in-circuit, input overdrive protection, as long as the current is limited to 10 mA as stated in [Absolute Maximum Ratings](#). [Figure 38](#) shows how a series input resistor may be added to the driven input to limit the input current. The added resistor contributes thermal noise at the amplifier input and its value should be kept to a minimum in noise-sensitive applications.

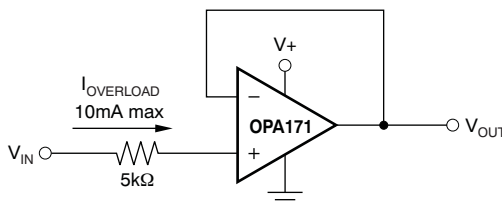

**Figure 38. Input Current Protection**

An ESD event produces a short duration, high-voltage pulse that is transformed into a short duration, high-current pulse as it discharges through a semiconductor device. The ESD protection circuits are designed to provide a current path around the operational amplifier core to prevent it from being damaged. The energy absorbed by the protection circuitry is then dissipated as heat.

When the operational amplifier connects into a circuit, the ESD protection components are intended to remain inactive and not become involved in the application circuit operation. However, circumstances may arise where an applied voltage exceeds the operating voltage range of a given pin. If this condition occurs, there is a risk that some of the internal ESD protection circuits may be biased on, and conduct current. Any such current flow occurs through ESD cells and rarely involves the absorption device.

If there is uncertainty about the ability of the supply to absorb this current, external Zener diodes may be added to the supply pins. Select the Zener voltage such that the diode does not turn on during normal operation.

However, its Zener voltage should be low enough so that the Zener diode conducts if the supply pin begins to rise above the safe operating supply voltage level.

## 8.2 Typical Application

Figure 39 shows a capacitive load drive solution using an isolation resistor. The OPA2171-EP device can be used capacitive loads such as cable shields, reference buffers, MOSFET gates, and diodes. The circuit uses an isolation resistor ( $R_{ISO}$ ) to stabilize the output of an op amp.  $R_{ISO}$  modifies the open loop gain of the system to ensure the circuit has sufficient phase margin.

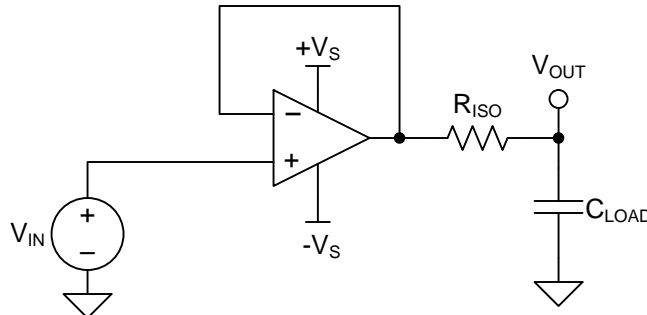

Figure 39. Unity-Gain Buffer with  $R_{ISO}$  Stability Compensation

### 8.2.1 Design Requirements

The design requirements are:

- Supply voltage: 30 V ( $\pm 15$  V)
- Capacitive loads: 100 pF, 1000 pF, 0.01  $\mu$ F, 0.1  $\mu$ F, and 1  $\mu$ F
- Phase margin: 45° and 60°

### 8.2.2 Detailed Design Procedure

Figure 39 shows a unity-gain buffer driving a capacitive load. Equation 1 shows the transfer function for the circuit in Figure 39. Not shown in Figure 39 is the open-loop output resistance of the op amp,  $R_o$ .

$$T(s) = \frac{1 + C_{LOAD} \times R_{ISO} \times s}{1 + (R_o + R_{ISO}) \times C_{LOAD} \times s} \quad (1)$$

The transfer function in Equation 1 has a pole and a zero. The frequency of the pole ( $f_p$ ) is determined by  $(R_o + R_{ISO})$  and  $C_{LOAD}$ . Components  $R_{ISO}$  and  $C_{LOAD}$  determine the frequency of the zero ( $f_z$ ). A stable system is obtained by selecting  $R_{ISO}$  such that the rate of closure (ROC) between the open-loop gain ( $A_{OL}$ ) and  $1/\beta$  is 20 dB/decade. Figure 40 depicts the concept. The  $1/\beta$  curve for a unity-gain buffer is 0 dB.

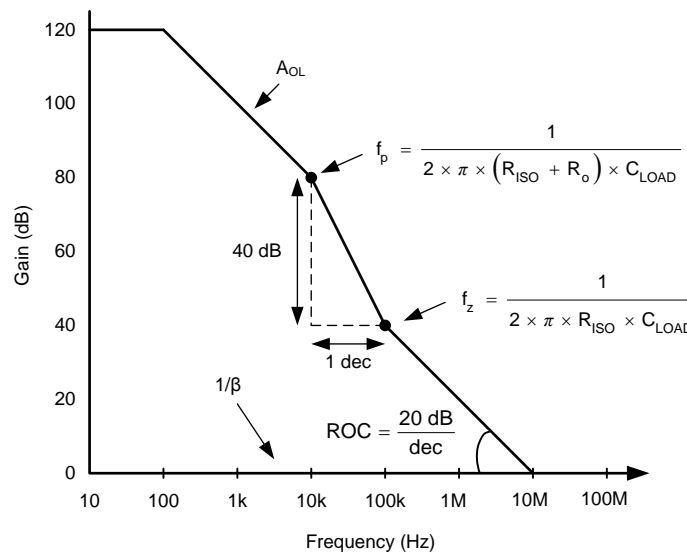

Figure 40. Unity-Gain Amplifier with  $R_{ISO}$  Compensation

### Typical Application (continued)

ROC stability analysis is typically simulated. The validity of the analysis depends on multiple factors, especially the accurate modeling of  $R_o$ . In addition to simulating the ROC, a robust stability analysis includes a measurement of overshoot percentage and AC gain peaking of the circuit using a function generator, oscilloscope, and gain and phase analyzer. Phase margin is then calculated from these measurements. Table 3 shows the overshoot percentage and AC gain peaking that correspond to phase margins of 45° and 60°. For more details on this design and other alternative devices that can be used in place of the OPA171, refer to the Precision Design, *Capacitive Load Drive Solution using an Isolation Resistor (TIPD128)*.

**Table 3. Phase Margin versus Overshoot and AC Gain Peaking**

| PHASE MARGIN | OVERSHOOT | AC GAIN PEAKING |
|--------------|-----------|-----------------|
| 45°          | 23.3%     | 2.35 dB         |
| 60°          | 8.8%      | 0.28 dB         |

#### 8.2.2.1 Capacitive Load and Stability

The dynamic characteristics of the OPA2171-EP have been optimized for commonly encountered operating conditions. The combination of low closed-loop gain and high capacitive loads decreases the phase margin of the amplifier and can lead to gain peaking or oscillations. As a result, heavier capacitive loads must be isolated from the output. The simplest way to achieve this isolation is to add a small resistor (for example,  $R_{OUT}$  equal to 50  $\Omega$ ) in series with the output. Figure 41 and Figure 42 illustrate graphs of small-signal overshoot versus capacitive load for several values of  $R_{OUT}$ . Also, refer to *Applications Bulletin AB-028 (SBOA015)*, available for download from [www.ti.com](http://www.ti.com) for details of analysis techniques and application circuits.

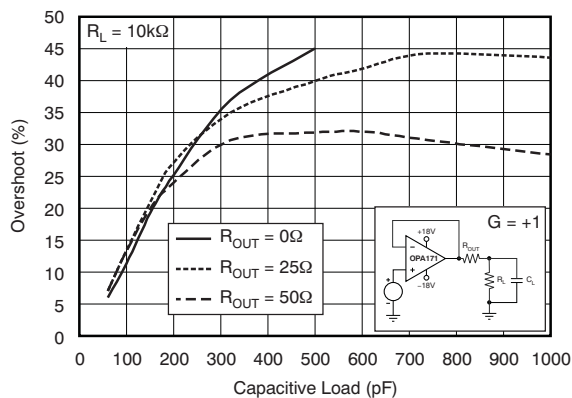

**Figure 41. Small-Signal Overshoot vs Capacitive Load (100-mV Output Step)**

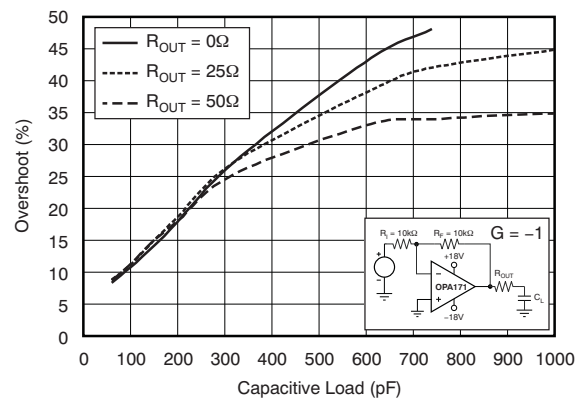

**Figure 42. Small-Signal Overshoot vs Capacitive Load (100-mV Output Step)**

### 8.2.3 Application Curve

The OPA2171-EP device meets the supply voltage requirements of 30 V. The OPA2171-EP device was tested for various capacitive loads and  $R_{ISO}$  was adjusted to achieve an overshoot corresponding to Table 3. Figure 43 shows the test results.

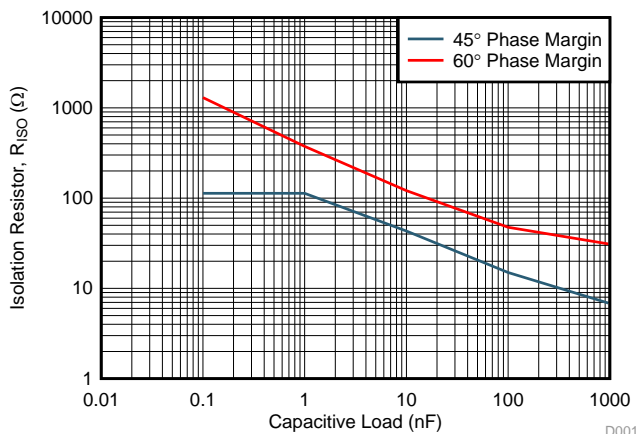

Figure 43.  $R_{ISO}$  vs  $C_{LOAD}$

## 9 Power Supply Recommendations

The OPA2171-EP is specified for operation from 4.5 V to 36 V ( $\pm 2.25$  V to  $\pm 18$  V); many specifications apply from  $-40^{\circ}\text{C}$  to  $125^{\circ}\text{C}$ . Parameters that can exhibit significant variance with regard to operating voltage or temperature are presented in the *Typical Characteristics* section.

### CAUTION

Supply voltages larger than 40 V can permanently damage the device; see the *Absolute Maximum Ratings* table.

Place 0.1- $\mu\text{F}$  bypass capacitors close to the power-supply pins to reduce errors coupling in from noisy or high-impedance power supplies. For detailed information on bypass capacitor placement, see the *Layout* section.

## 10 Layout

### 10.1 Layout Guidelines

For best operational performance of the device, TI recommends good printed circuit board (PCB) layout practices. Low-loss, 0.1- $\mu$ F bypass capacitors should be connected between each supply pin and ground, placed as close to the device as possible. A single bypass capacitor from V+ to ground is applicable for single-supply applications.

### 10.2 Layout Example

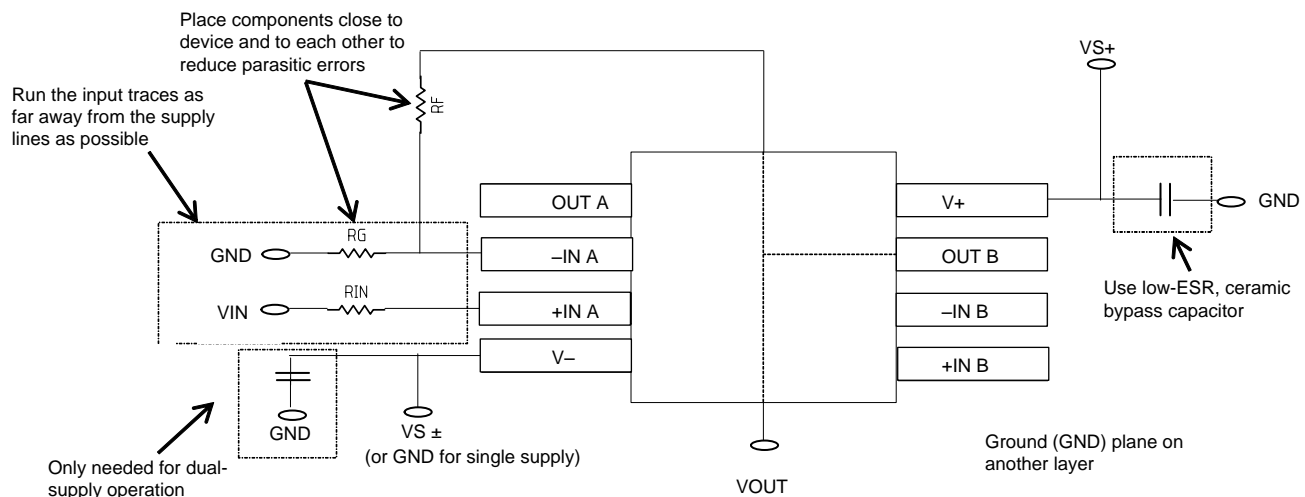

**Figure 44. Operational Amplifier Board Layout for Noninverting Configuration**

## 11 Device and Documentation Support

### 11.1 Community Resources

The following links connect to TI community resources. Linked contents are provided "AS IS" by the respective contributors. They do not constitute TI specifications and do not necessarily reflect TI's views; see TI's [Terms of Use](#).

**TI E2E™ Online Community** *TI's Engineer-to-Engineer (E2E) Community*. Created to foster collaboration among engineers. At [e2e.ti.com](http://e2e.ti.com), you can ask questions, share knowledge, explore ideas and help solve problems with fellow engineers.

**Design Support** *TI's Design Support* Quickly find helpful E2E forums along with design support tools and contact information for technical support.

### 11.2 Trademarks

E2E is a trademark of Texas Instruments.  
All other trademarks are the property of their respective owners.

### 11.3 Electrostatic Discharge Caution



These devices have limited built-in ESD protection. The leads should be shorted together or the device placed in conductive foam during storage or handling to prevent electrostatic damage to the MOS gates.

### 11.4 Glossary

[SLYZ022](#) — *TI Glossary*.

This glossary lists and explains terms, acronyms, and definitions.

## 12 Mechanical, Packaging, and Orderable Information

The following pages include mechanical, packaging, and orderable information. This information is the most current data available for the designated devices. This data is subject to change without notice and revision of this document. For browser-based versions of this data sheet, refer to the left-hand navigation.

**PACKAGING INFORMATION**

| Orderable Device | Status<br>(1) | Package Type | Package Drawing | Pins | Package Qty | Eco Plan<br>(2)         | Lead/Ball Finish<br>(6) | MSL Peak Temp<br>(3) | Op Temp (°C) | Device Marking<br>(4/5) | Samples                 |
|------------------|---------------|--------------|-----------------|------|-------------|-------------------------|-------------------------|----------------------|--------------|-------------------------|-------------------------|
| OPA2171MDCUTEPE  | ACTIVE        | VSSOP        | DCU             | 8    | 250         | Green (RoHS & no Sb/Br) | CU NIPDAU               | Level-1-260C-UNLIM   | -55 to 125   | ZGAA                    | <a href="#">Samples</a> |
| V62/15605-01XE   | ACTIVE        | VSSOP        | DCU             | 8    | 250         | Green (RoHS & no Sb/Br) | CU NIPDAU               | Level-1-260C-UNLIM   | -55 to 125   | ZGAA                    | <a href="#">Samples</a> |

(1) The marketing status values are defined as follows:

**ACTIVE:** Product device recommended for new designs.

**LIFEBUY:** TI has announced that the device will be discontinued, and a lifetime-buy period is in effect.

**NRND:** Not recommended for new designs. Device is in production to support existing customers, but TI does not recommend using this part in a new design.

**PREVIEW:** Device has been announced but is not in production. Samples may or may not be available.

**OBsolete:** TI has discontinued the production of the device.

(2) Eco Plan - The planned eco-friendly classification: Pb-Free (RoHS), Pb-Free (RoHS Exempt), or Green (RoHS & no Sb/Br) - please check <http://www.ti.com/productcontent> for the latest availability information and additional product content details.

**TBD:** The Pb-Free/Green conversion plan has not been defined.

**Pb-Free (RoHS):** TI's terms "Lead-Free" or "Pb-Free" mean semiconductor products that are compatible with the current RoHS requirements for all 6 substances, including the requirement that lead not exceed 0.1% by weight in homogeneous materials. Where designed to be soldered at high temperatures, TI Pb-Free products are suitable for use in specified lead-free processes.

**Pb-Free (RoHS Exempt):** This component has a RoHS exemption for either 1) lead-based flip-chip solder bumps used between the die and package, or 2) lead-based die adhesive used between the die and leadframe. The component is otherwise considered Pb-Free (RoHS compatible) as defined above.

**Green (RoHS & no Sb/Br):** TI defines "Green" to mean Pb-Free (RoHS compatible), and free of Bromine (Br) and Antimony (Sb) based flame retardants (Br or Sb do not exceed 0.1% by weight in homogeneous material)

(3) MSL, Peak Temp. - The Moisture Sensitivity Level rating according to the JEDEC industry standard classifications, and peak solder temperature.

(4) There may be additional marking, which relates to the logo, the lot trace code information, or the environmental category on the device.

(5) Multiple Device Markings will be inside parentheses. Only one Device Marking contained in parentheses and separated by a "~" will appear on a device. If a line is indented then it is a continuation of the previous line and the two combined represent the entire Device Marking for that device.

(6) Lead/Ball Finish - Orderable Devices may have multiple material finish options. Finish options are separated by a vertical ruled line. Lead/Ball Finish values may wrap to two lines if the finish value exceeds the maximum column width.

**Important Information and Disclaimer:** The information provided on this page represents TI's knowledge and belief as of the date that it is provided. TI bases its knowledge and belief on information provided by third parties, and makes no representation or warranty as to the accuracy of such information. Efforts are underway to better integrate information from third parties. TI has taken and continues to take reasonable steps to provide representative and accurate information but may not have conducted destructive testing or chemical analysis on incoming materials and chemicals. TI and TI suppliers consider certain information to be proprietary, and thus CAS numbers and other limited information may not be available for release.

In no event shall TI's liability arising out of such information exceed the total purchase price of the TI part(s) at issue in this document sold by TI to Customer on an annual basis.

**OTHER QUALIFIED VERSIONS OF OPA2171-EP :**

- Catalog: [OPA2171](#)
- Automotive: [OPA2171-Q1](#)

## NOTE: Qualified Version Definitions:

- Catalog - TI's standard catalog product
- Automotive - Q100 devices qualified for high-reliability automotive applications targeting zero defects

## TAPE AND REEL INFORMATION



### QUADRANT ASSIGNMENTS FOR PIN 1 ORIENTATION IN TAPE



\*All dimensions are nominal

| Device         | Package Type | Package Drawing | Pins | SPQ | Reel Diameter (mm) | Reel Width W1 (mm) | A0 (mm) | B0 (mm) | K0 (mm) | P1 (mm) | W (mm) | Pin1 Quadrant |
|----------------|--------------|-----------------|------|-----|--------------------|--------------------|---------|---------|---------|---------|--------|---------------|
| OPA2171MDCUTEP | VSSOP        | DCU             | 8    | 250 | 180.0              | 8.4                | 2.25    | 3.35    | 1.05    | 4.0     | 8.0    | Q3            |

TAPE AND REEL BOX DIMENSIONS



\*All dimensions are nominal

| Device         | Package Type | Package Drawing | Pins | SPQ | Length (mm) | Width (mm) | Height (mm) |
|----------------|--------------|-----------------|------|-----|-------------|------------|-------------|
| OPA2171MDCUTEP | VSSOP        | DCU             | 8    | 250 | 202.0       | 201.0      | 28.0        |

DCU (R-PDSO-G8)

PLASTIC SMALL-OUTLINE PACKAGE (DIE DOWN)

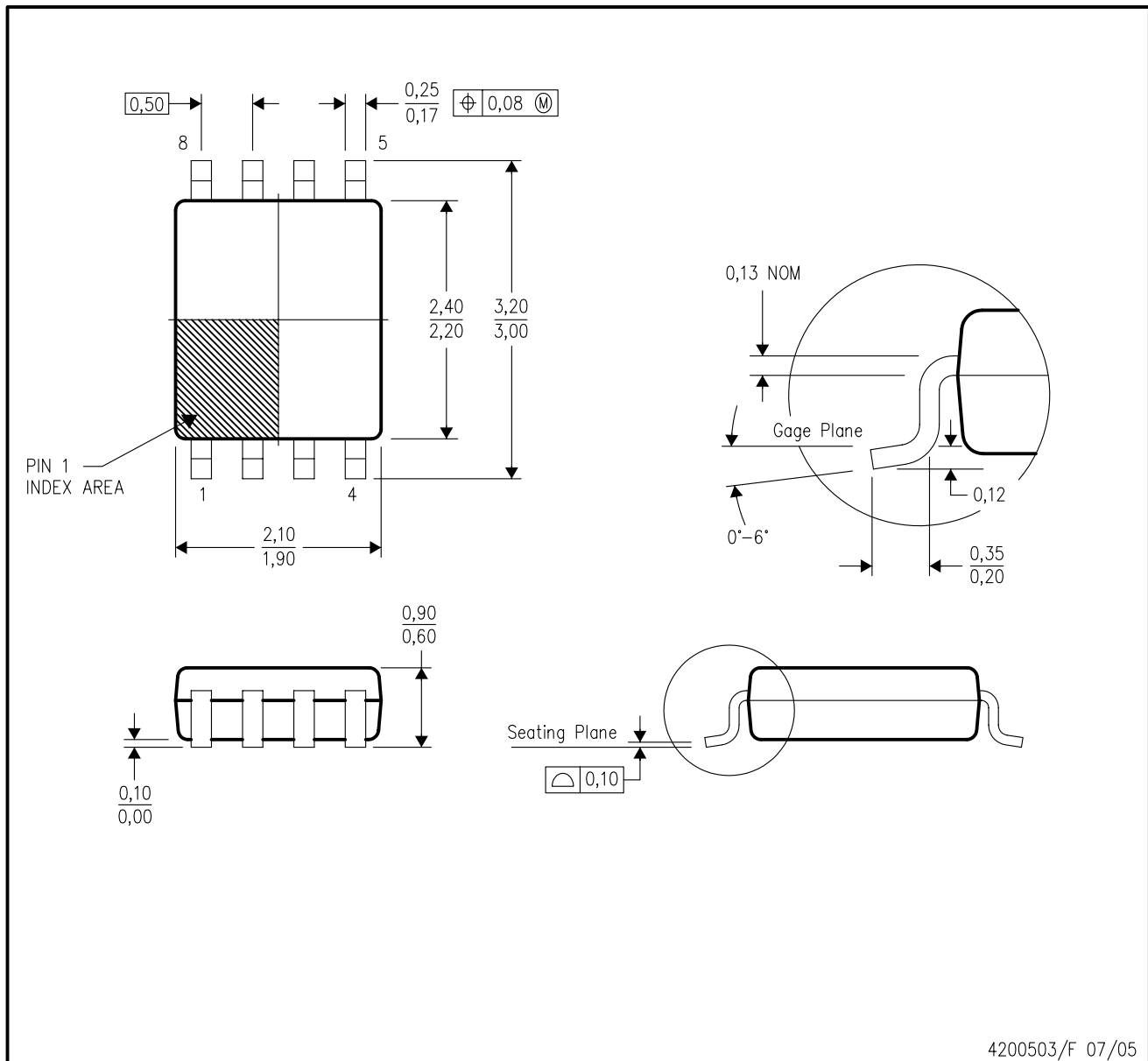

- NOTES:
- All linear dimensions are in millimeters.
  - This drawing is subject to change without notice.
  - Body dimensions do not include mold flash or protrusion. Mold flash and protrusion shall not exceed 0.15 per side.
  - Falls within JEDEC MO-187 variation CA.

DCU (S-PDSO-G8)

PLASTIC SMALL OUTLINE PACKAGE (DIE DOWN)

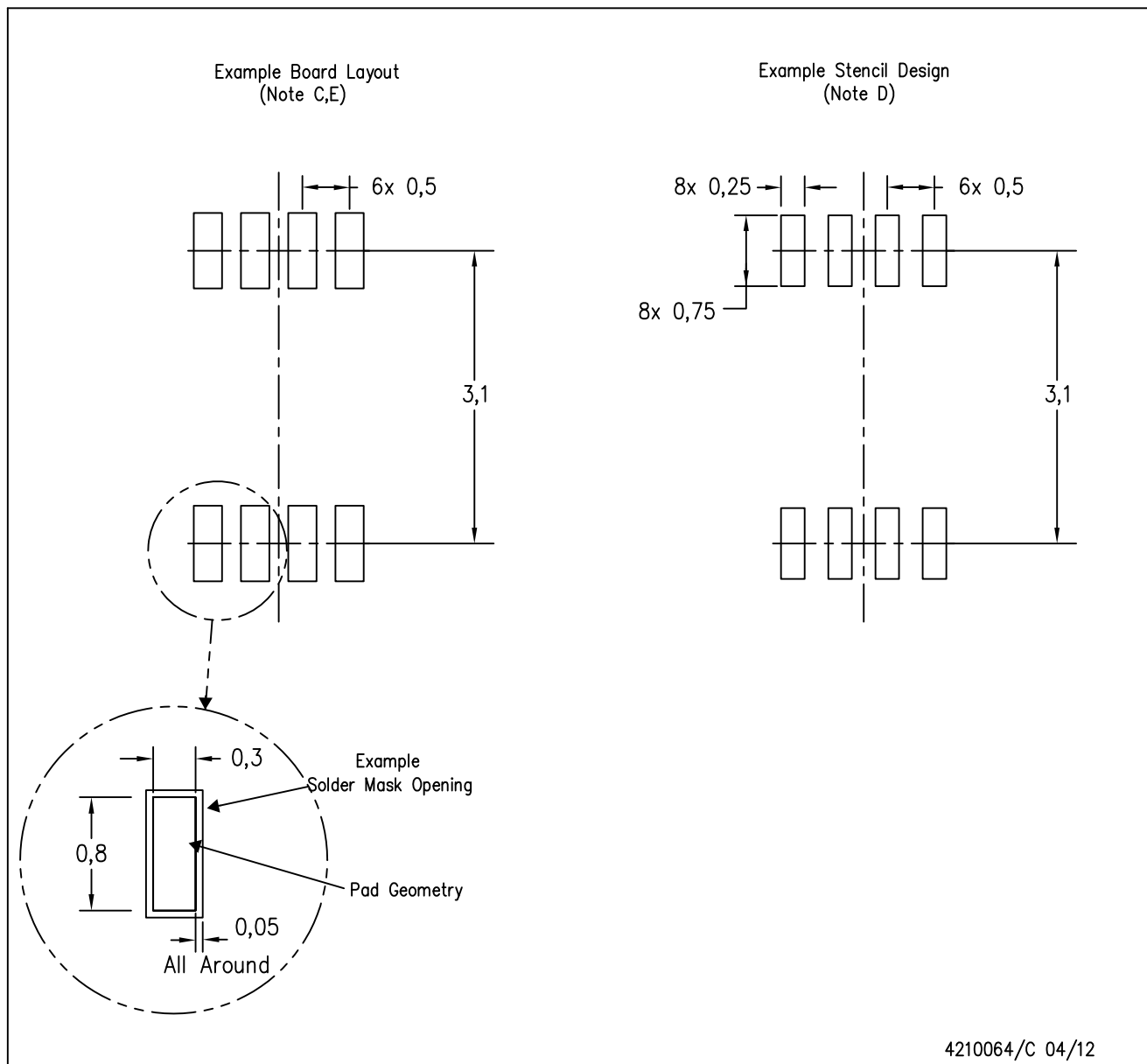

- NOTES:
- A. All linear dimensions are in millimeters.
  - B. This drawing is subject to change without notice.
  - C. Publication IPC-7351 is recommended for alternate designs.
  - D. Laser cutting apertures with trapezoidal walls and also rounding corners will offer better paste release. Customers should contact their board assembly site for stencil design recommendations. Refer to IPC-7525 for other stencil recommendations.
  - E. Customers should contact their board fabrication site for solder mask tolerances between and around signal pads.

## IMPORTANT NOTICE AND DISCLAIMER

TI PROVIDES TECHNICAL AND RELIABILITY DATA (INCLUDING DATASHEETS), DESIGN RESOURCES (INCLUDING REFERENCE DESIGNS), APPLICATION OR OTHER DESIGN ADVICE, WEB TOOLS, SAFETY INFORMATION, AND OTHER RESOURCES "AS IS" AND WITH ALL FAULTS, AND DISCLAIMS ALL WARRANTIES, EXPRESS AND IMPLIED, INCLUDING WITHOUT LIMITATION ANY IMPLIED WARRANTIES OF MERCHANTABILITY, FITNESS FOR A PARTICULAR PURPOSE OR NON-INFRINGEMENT OF THIRD PARTY INTELLECTUAL PROPERTY RIGHTS.

These resources are intended for skilled developers designing with TI products. You are solely responsible for (1) selecting the appropriate TI products for your application, (2) designing, validating and testing your application, and (3) ensuring your application meets applicable standards, and any other safety, security, or other requirements. These resources are subject to change without notice. TI grants you permission to use these resources only for development of an application that uses the TI products described in the resource. Other reproduction and display of these resources is prohibited. No license is granted to any other TI intellectual property right or to any third party intellectual property right. TI disclaims responsibility for, and you will fully indemnify TI and its representatives against, any claims, damages, costs, losses, and liabilities arising out of your use of these resources.

TI's products are provided subject to TI's Terms of Sale ([www.ti.com/legal/termsofsale.html](http://www.ti.com/legal/termsofsale.html)) or other applicable terms available either on [ti.com](http://ti.com) or provided in conjunction with such TI products. TI's provision of these resources does not expand or otherwise alter TI's applicable warranties or warranty disclaimers for TI products.

Mailing Address: Texas Instruments, Post Office Box 655303, Dallas, Texas 75265  
Copyright © 2019, Texas Instruments Incorporated

## Looking for pricing, stock, or lifecycle information?

Click below to explore more details on WIN SOURCE:

 [View OPA2171MDCUTEP on WIN SOURCE](#)

 [Texas Instruments](#) Information

## Optimize Your Supply Chain with WIN SOURCE Solutions

-  Global Sourcing Solution
-  Obsolete Management
-  Cost Control Management
-  Shortage Management
-  Alternative Solution
-  Excess Inventory Management