



**THE DATASHEET OF
ATS675LSETN-LT-T**



Self-Calibrating TPOS Speed Sensor IC Optimized for Automotive Cam Sensing Applications

Features and Benefits

- Optimized for automotive camshaft sensing
- True target state recognition at device power-on (TPOS) and at zero target speed
- Chopper stabilization reduces offset drift
- Digital output polarity option: follow or invert target profile
- Rapid calibration and transition to Running mode
- Automatic Gain Control (AGC) during calibration eliminates effects of air gap variations
- Tight timing accuracy over full operating temperature range
- Operation at supply voltages as low as 3.3 V
- Undervoltage lockout (UVLO)

Package: 4-pin SIP (suffix SE)

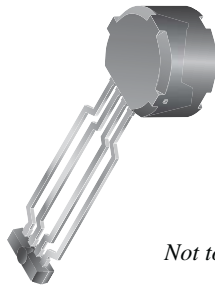

Not to scale

Description

The ATS675 is a next generation member of the Allegro® True Power-On State (TPOS) sensor IC family, offering improved accuracy compared to prior generations, and performing at absolutely zero target speed. An output polarity option allows customization for specific applications.

The device incorporates a single Hall-element IC with an optimized custom magnetic circuit that switches in response to magnetic signals. The resulting output of the device is a digital representation of a ferromagnetic target profile.

The IC contains a sophisticated digital circuit designed to eliminate the detrimental effects of magnetic and system offsets. Signal processing is used to provide target state recognition at zero rotational speed, consistent switchpoints regardless of air gap, and dynamically adapt device performance to the typical operating conditions found in automotive environments, particularly cam sensing applications.

High-resolution peak-detecting DACs are used to set the adaptive switching thresholds of the device. The ATS675 also includes a filter that increases the noise immunity and the signal-to-noise ratio of the IC.

The device is provided in a 4-pin SIP package (SE) that is lead (Pb) free with 100% matte tin leadframe plating.

Typical Application

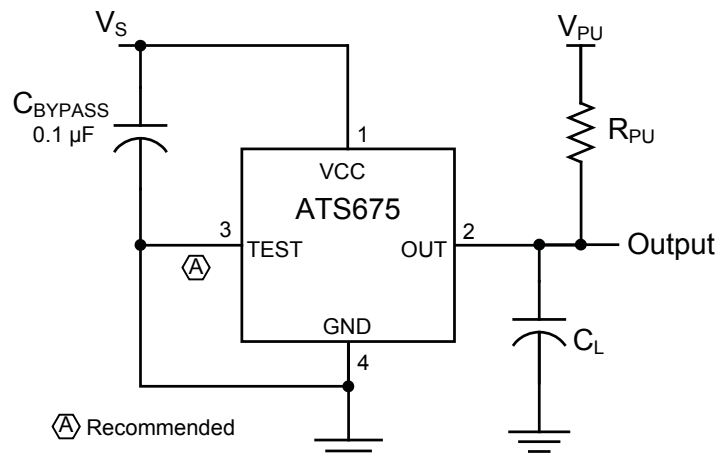

Figure 1. Operational circuit for the ATS675

ATS675LSE

Self-Calibrating TPOS Speed Sensor IC Optimized for Automotive Cam Sensing Applications

Selection Guide

Part Number	Output Protocol	Packing*
ATS675LSETN-LT-T	Output low opposite target tooth	13-in. reel, 450 pieces per reel
ATS675LSETN-HT-T	Output high opposite target tooth	



*Contact Allegro for additional packing options

Absolute Maximum Ratings

Characteristic	Symbol	Notes	Rating	Unit
Supply Voltage	V_{CC}	Refer to Power Derating curve	28	V
Reverse Supply Voltage	V_{RCC}		-18	V
Reverse Output Voltage	V_{ROUT}		-0.5	V
Reverse Supply Current	I_{RCC}		-50	mA
Output Current	$I_{OUT(sink)}$	Internal current limiting is intended to protect the device from output short circuits, but is not intended for continuous operation.	30	mA
Reverse Output Current	I_{ROUT}		-50	mA
Operating Ambient Temperature	T_A	Range L	-40 to 150	°C
Maximum Junction Temperature	$T_J(max)$		165	°C
Storage Temperature	T_{stg}		-65 to 170	°C

Functional Block Diagram

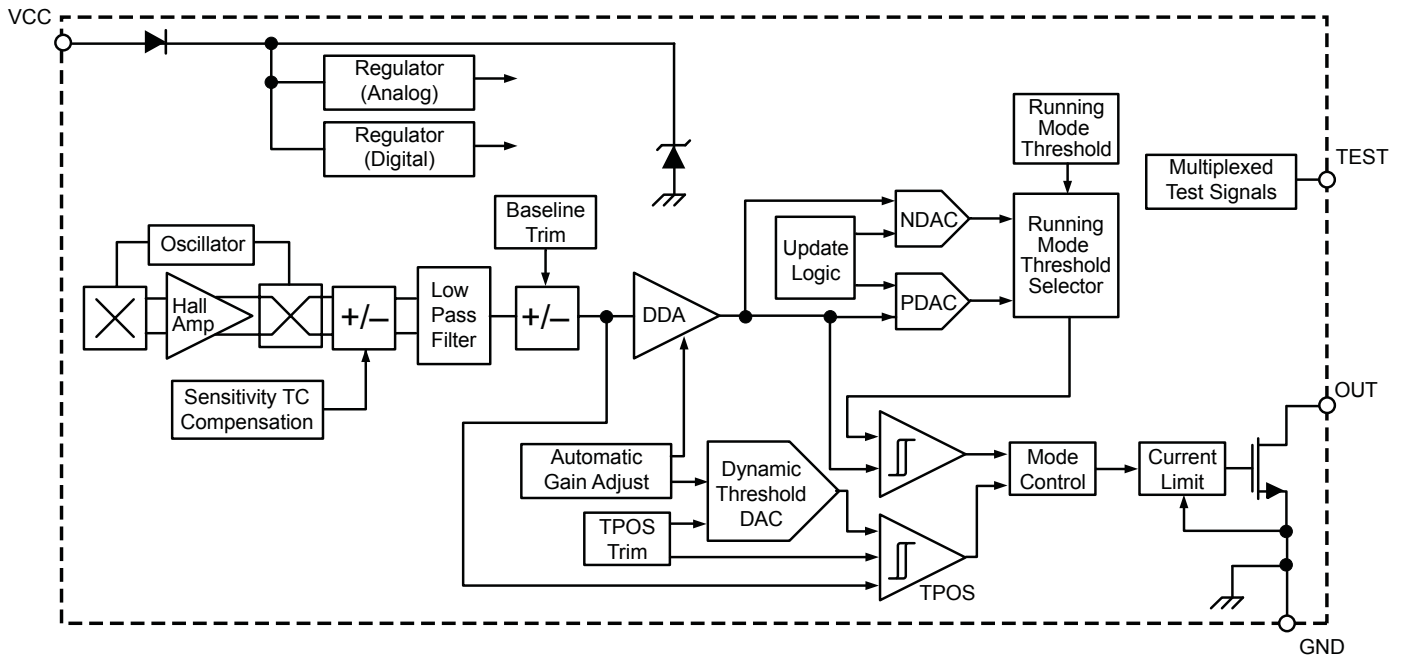

Pin-out Diagram

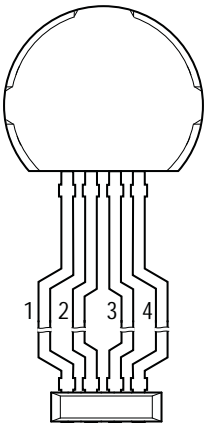

Terminal List

Number	Name	Function
1	VCC	Supply voltage
2	OUT	Open drain output
3	TEST	Test pin; connection to GND recommended
4	GND	Ground

OPERATING CHARACTERISTICS Valid using reference target 8X, T_A, T_J , and V_{CC} within specification, unless otherwise noted

Characteristics	Symbol	Test Conditions	Min.	Typ. ¹	Max.	Unit	
Electrical Characteristics							
Supply Voltage ²	V_{CC}	Operating, $T_J < T_J(\text{max})$	3.3	–	24	V	
Undervoltage Lockout	V_{CCUV}	$V_{CC} = 0 \rightarrow 5 \text{ V}$ or $5 \rightarrow 0 \text{ V}$	–	–	3.3	V	
Supply Zener Clamp Voltage	$V_{ZSUPPLY}$	$I_{CC} = I_{CC}(\text{max}) + 3 \text{ mA}$, $T_A = 25^\circ\text{C}$	28	33	40	V	
Supply Zener Current ³	$I_{ZSUPPLY}$	$V_{SUPPLY} = 28 \text{ V}$	–	–	13	mA	
Supply Current	I_{CC}		–	6.5	10	mA	
Reverse Battery Current ⁴	I_{RCC}	$V_{RCC} = -18 \text{ V}$	–	–	-10	mA	
Chopping Frequency	f_c		–	500	–	kHz	
TEST Pin Zener Clamp Voltage ⁵	V_{ZTEST}		–	6	–	V	
Power-On Characteristics							
Power-On Time ⁶	t_{PO}	$V_{CC} > V_{CC}(\text{min})$, $f_{SIG} < 200 \text{ Hz}$	–	–	1	ms	
Output Stage Characteristics							
Output Profile Polarity ⁷		LT option, measured as V_{OUT} , device electrically connected as in figure 1	Opposite to Tooth (Output State = On)	–	Low	–	V
			Opposite to Valley (Output State = Off)	–	High	–	V
		HT option, measured as V_{OUT} , device electrically connected as in figure 1	Opposite to Tooth (Output State = Off)	–	High	–	V
			Opposite to Valley (Output State = On)	–	Low	–	V
Output On Voltage	$V_{OUT(\text{SAT})}$	$I_{OUT} = 10 \text{ mA}$, Output State = On	–	–	400	mV	
		$I_{OUT} = 15 \text{ mA}$, Output State = On	–	–	450	mV	
Output Zener Voltage	V_{ZOUT}	$T_A = 25^\circ\text{C}$, $I_{OUT} = 3 \text{ mA}$	30	–	–	V	
Output Current Limit	I_{OUTLIM}	Output State = On	30	50	80	mA	
Output Leakage Current	I_{OUTOFF}	$V_{OUT} = 24 \text{ V}$, Output State = Off	–	–	10	μA	
Output Rise Time	t_r	$R_{PU} = 1 \text{ k}\Omega$, $C_L = 4.7 \text{ nF}$, $V_{PU} = 5 \text{ V}$	–	10	–	μs	
Output Fall Time ⁸	$t_f(\text{OUT})$	Measured from 90% to 10%, $T_A = 25^\circ\text{C}$, $R_{PU} = 1 \text{ k}\Omega$, $C_L = 4.7 \text{ nF}$, (see figure 2)	$V_{PU} = 5 \text{ V}$	0.8	1.1	1.5	μs
			$V_{PU} = 12 \text{ V}$	–	1.6	–	μs
Output Fall Time Variation with Temperature	$\Delta t_f(\text{OUT})$	Maximum variation from $T_A = 25^\circ\text{C}$ to -40°C and then to 150°C	–	± 20	–	%	
Output Delay Time ⁹	$t_d(\text{OUT})$	4 kHz sinusoidal input signal, falling electrical edge (see figure 2)	–	18	–	μs	
Performance Characteristics							
Operational Air Gap Range ¹⁰	AG_{TPOS}	TPOS functionality guaranteed	0.5	–	3.0	mm	
Extended Air Gap Range ¹¹	AG_{EXTMAX}	Output switching in Running mode, TPOS function not guaranteed	3.0	–	4.5	mm	
Analog Signal Bandwidth	BW	Equivalent to -3 dB cutoff frequency	–	20	–	kHz	
Tooth Speed	f_{SIG}	Tooth signal frequency, sinusoidal input signal	0	–	8000	Hz	

Continued on the next page...

OPERATING CHARACTERISTICS (continued) Valid using reference target 8X, T_A , T_J , and V_{CC} within specification, unless otherwise noted

Characteristics	Symbol	Test Conditions	Min.	Typ. ¹	Max.	Unit
Calibration⁷						
Initial Calibration ^{12,13}	CAL _I	Quantity of mechanical falling edges used to determine Running mode switchpoints level	–	1	3	edge
TPO to Running Mode Adjustment	CAL _{TPO}	Quantity of mechanical falling edges after CAL _I to transition from TPOS switchpoints level to Running mode switchpoints level	–	–	1	tooth
Running Mode Switchpoint Characteristics						
Running Mode Switchpoint	B _{ST}	% of peak-to-peak, referenced to tooth signal (see figure 4)	–	30	–	% _{pk-pk}
Internal Hysteresis	B _{HYS(int)}	% of peak-to-peak signal	–	10	–	%
Signal Characteristics						
Maximum Allowable Signal Reduction ¹⁴	B _{reduce}	Reduction in V _{PROC} amplitude from V _{PROC(high)} to lowest peak V _{PROC(reduce)} ; all specifications within range (see figure 3)	–	–	15	% _{pk-pk}
		Reduction in V _{PROC} amplitude from V _{PROC(high)} to lowest peak V _{PROC(reduce)} ; output switches, other specifications may be out of range (see figure 3)	–	–	25	% _{pk-pk}
Relative Timing Accuracy ^{12,15}	Err _{RELR}	Rising mechanical edges after initial calibration, gear speed = 1000 rpm, target eccentricity < 0.1 mm	–	0.4	0.8	deg.
	Err _{RELF}	Falling mechanical edges after initial calibration, gear speed = 1000 rpm, target eccentricity < 0.1 mm	–	0.5	1.0	deg.

¹Typical values are at $T_A = 25^\circ\text{C}$ and $V_{CC} = 12\text{ V}$. Performance may vary for individual units, within the specified maximum and minimum limits.

²Maximum voltage must be adjusted for power dissipation and junction temperature; see Power Derating section.

³Maximum current limit is equal to $I_{CC(max)} + 3\text{ mA}$.

⁴Negative current is defined as conventional current coming out of (sourced from) the specified device terminal.

⁵Sustained voltages beyond the clamp voltage may cause permanent damage to the IC.

⁶Power-On Time is the duration from when V_{CC} rises above $V_{CC(min)}$ until a valid output state is realized.

⁷For additional information see the Functional Description section.

⁸Characterization data shows 12 V fall time to be 1.5 times longer than 5 V fall time. See figure 2.

⁹Output Delay Time is the duration from when a crossing of the magnetic signal switching level, B_{ST}, occurs to when the electrical output signal, V_{OUT}, reaches 90% of V_{OUT(high)}.

¹⁰The Operational Air Gap Range is the range of installation air gaps within which the TPOS (True Power-On State) function is guaranteed to correctly detect a tooth when powered-on opposite a tooth and correctly detecting a valley when powered-on opposite a valley, using reference target 8X.

¹¹The Extended Air Gap Range is a range of installation air gaps, larger than AG_{TPOS}, within which the device will accurately detect target features in Running mode, but TPOS functionality is NOT guaranteed, possibly resulting in undetected target features during Initial Calibration. Relative Timing Accuracy (Err_{REL}) not guaranteed in Extended Air Gap Range.

¹²The term *mechanical edge* refers to a target feature, such as the side of a gear tooth, passing opposite the device. A rising edge is a transition from a valley to a tooth, and a falling edge is a transition from a tooth to a valley. See figure 6.

¹³Signal frequency for CAL_I is $f_{SIG} < 200\text{ Hz}$.

¹⁴Running mode; 4X target used. The Processed Internal Signal, V_{PROC}, is the internal signal generated by the Hall detection circuitry and normalized by Automatic Gain Control.

¹⁵Relative Timing Accuracy refers to the difference in accuracy, relative to a 0.5 mm air gap, through the entire Operational Air Gap Range, after initial calibration; gear speed = 1000 rpm, target eccentricity < 0.1 mm. See figure 7.

Definitions of Operating Characteristics

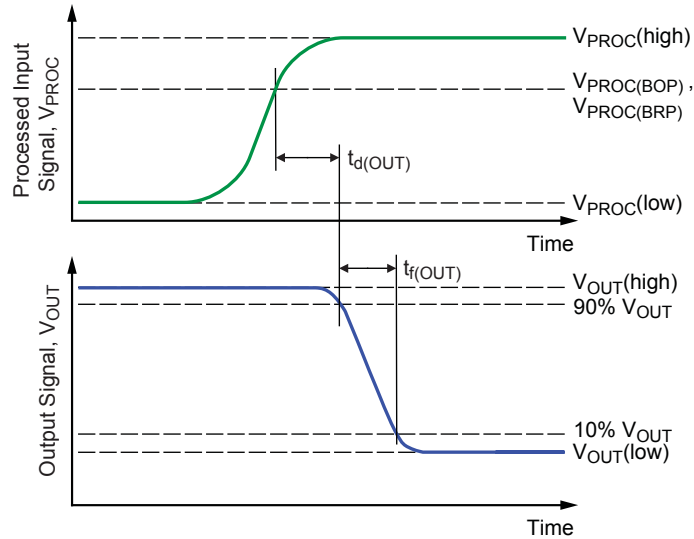

Figure 2. Definition of Output Delay Time, $t_{d(OUT)}$, and Output Fall Time, $t_{f(OUT)}$.

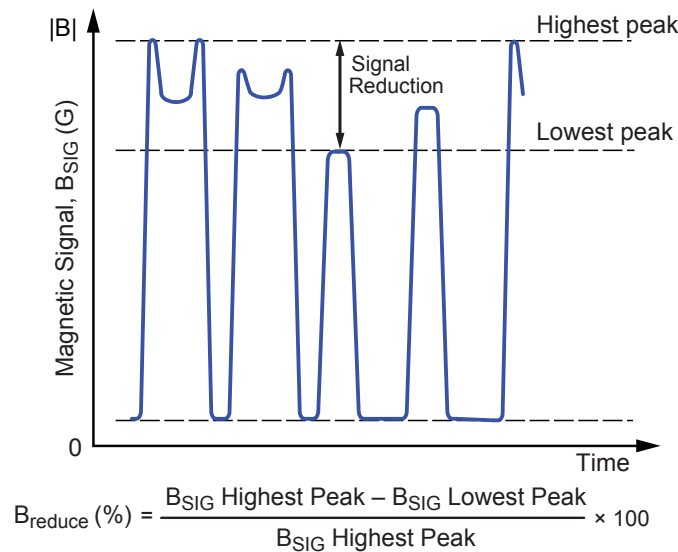
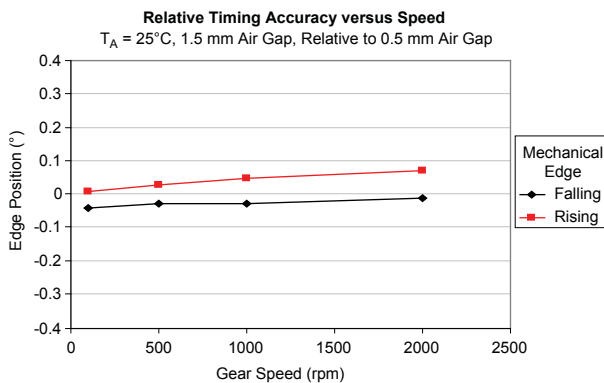
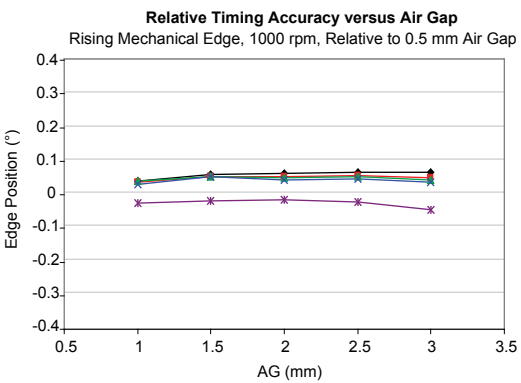
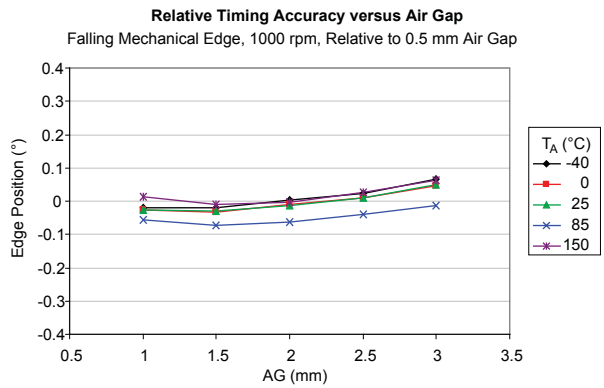
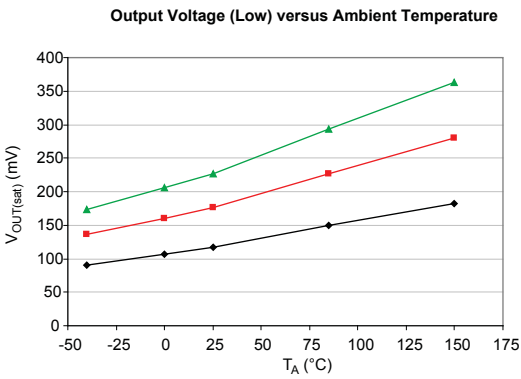
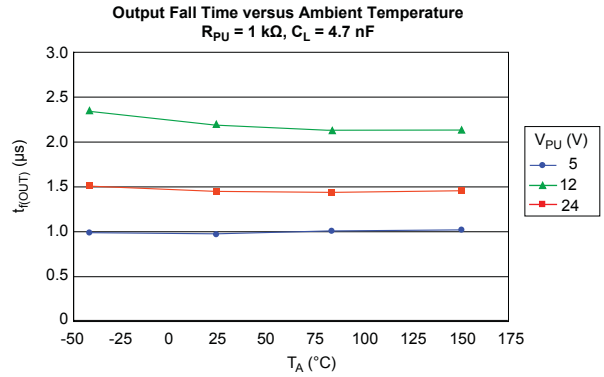
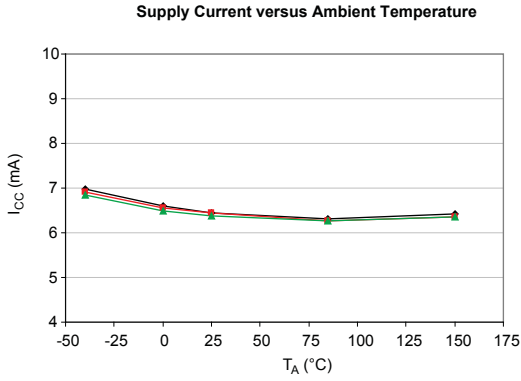

Figure 3. Definition of Maximum Allowable Signal Reduction, B_{reduce} , as a percentage of the overall magnetic signal.

Characteristic Performance



Thermal Characteristics may require derating at maximum conditions, see application information

Characteristic	Symbol	Test Conditions*	Value	Units
Package Thermal Resistance	$R_{\theta JA}$	1-layer PCB with copper limited to solder pads	101	$^{\circ}\text{C}/\text{W}$
		2-layer PCB with copper limited to solder pads and 3.57 in. ² of copper area each side	77	$^{\circ}\text{C}/\text{W}$

*Additional thermal information available on the Allegro website

Power Derating Curve

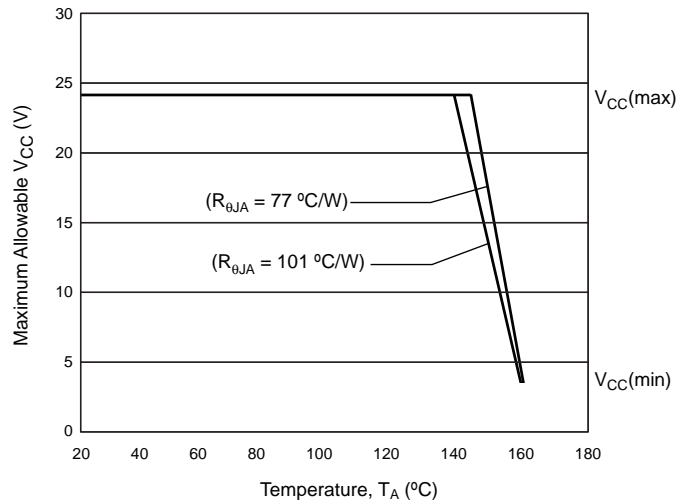

Power Dissipation versus Ambient Temperature

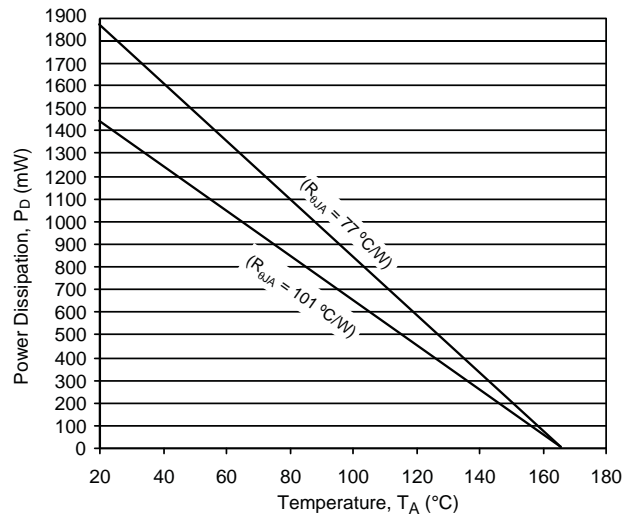

Reference Target 8x

Characteristic	Symbol	Test Conditions	Typ.	Unit	Symbol Key
Outside Diameter	D_o	Outside diameter of target	120	mm	
Face Width	F	Breadth of tooth, with respect to branded face	6	mm	
Circular Tooth Length	t	Length of tooth, with respect to branded face; measured at D_o	23.6	mm	
Circular Valley Length	t_v	Length of valley, with respect to branded face; measured at D_o	23.6	mm	
Tooth Whole Depth	h_t		5	mm	
Material		CRS 1018	-	-	

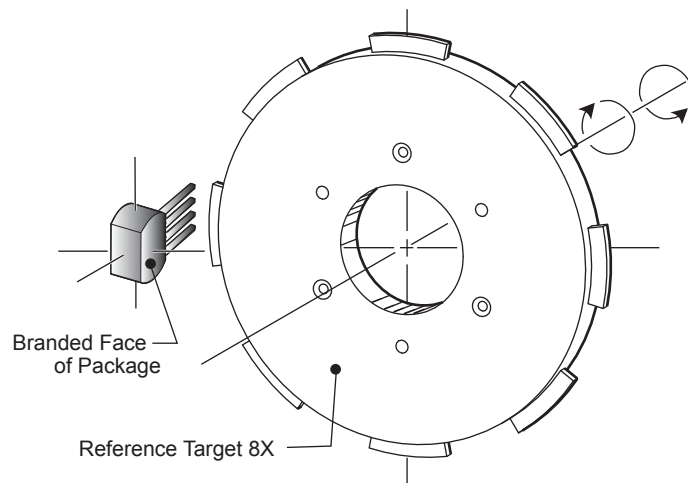

Figure 4. Configuration with Reference Target

Functional Description

Internal Electronics

This device contains a self-calibrating Hall effect IC that includes a Hall element, a temperature compensated amplifier, and offset cancellation circuitry. The IC also contains a voltage regulator that provides supply noise rejection over the operating voltage range. The Hall transducers and the electronics are integrated on the same silicon substrate by a proprietary BiCMOS process. Changes in temperature do not greatly affect this device, due to the stable amplifier design and the offset rejection circuitry. The Hall IC supports a chopper stabilized Hall element that measures the intensity of magnetic gradients and provides an electrical signal that represents the target features.

Hall Technology

The ATS675 contains a single-chip Hall effect sensor IC, a 4-pin leadframe, a specially designed rare-earth pellet, and a ferrous pole piece (a precisely-mounted magnetic field concentrator). The Hall IC supports a chopper stabilized Hall element that measures the magnetic gradient created by the passing of a ferromagnetic object. This is illustrated in figure 5. The difference in the magnetic gradients created by teeth and valleys allows the devices to generate a digital output signal that is representative of the target features.

Output Profile Polarity (LT/HT Option)

Device output, V_{OUT} , is a digital representation of the mechanical profile of the target, as illustrated in figure 6. The customer can choose the relative polarity of the output waveform. This assigns the polarity opposite tooth features (the inverse polarity

will be output opposite valley features). The LT option sets V_{OUT} low when a tooth is opposite the device, and the HT option sets V_{OUT} high when a target tooth is opposite the device. This polarity assignment applies throughout device operation. This ease of use reduces design time and incremental assembly costs for most applications.

Automatic Gain Control (AGC)

The Automatic Gain Control (AGC) feature ensures that the ATS675 initial switching thresholds are isolated from the effects of changes in the effective air gap (the total distance between the Hall element and the nearest feature of the target). AGC is implemented by unique patented self-calibrating circuitry, and normalizes the sensed magnetic gradient so the internal processed signal falls within the optimum processing range.

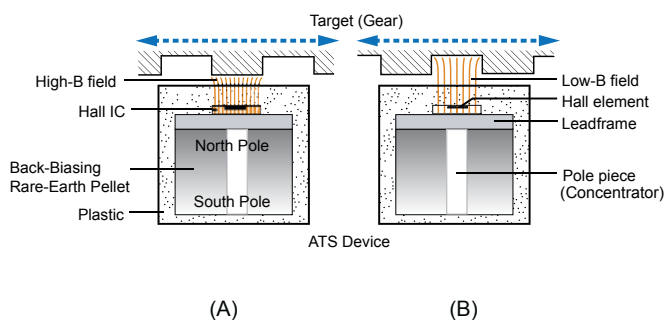

Figure 5. Application cross-section: (A) target tooth opposite device, and (B) target valley opposite device

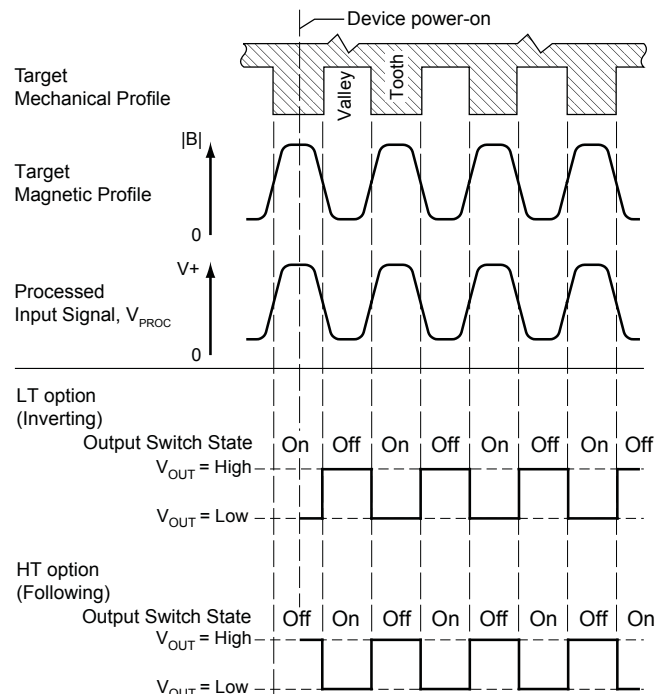

Figure 6. Output Profile Polarity options allow selection of V_{OUT} either inverted (LT option), or in-phase with the target profile (HT option), when electrically connected as in figure 1.

AGC is activated during the Initial Calibration stage at each power-on. The device measures the peak-to-peak application magnetic gradient, and then the gain of the sensor IC is adjusted to normalize the internal processed signal, V_{PROC} , to accommodate any input signal amplitude within the specified Operating Magnetic Signal Range, B_{SIG} . AGC is referenced to the internal magnetic baseline. At the end of the Initial Calibration stage, the AGC results are latched and they are not readjusted while the device remains powered-on.

Power Supply Protection

The ATS675 provides features for protecting the device against power supply aberrations:

Undervoltage Lockout When the supply voltage falls below the undervoltage lockout level, V_{CCUV} , the device Output State changes to Off. The device remains in that state until the voltage level is restored to the V_{CC} operating range. Changes in the target magnetic gradient have no effect until that voltage level is restored. This prevents false signals caused by undervoltage conditions from propagating to the output of the sensor IC.

EMC Protection The ATS675 contains an on-chip regulator that operates throughout a wide range of supply voltage levels. For applications using an unregulated power supply, protection against transients may be added externally. For applications using a regulated supply line, EMI and RFI protection may still be required. Contact Allegro for information on EMC specification compliance.

Operating Modes

The device provides three operating modes: TPOS, Calibration, and Running. TPOS and Calibration initialize simultaneously at power-on. TPOS generates immediate device output, controlling device switching while the calibration functions are performed. After calibration is complete, normal operation in Running mode begins.

TPOS (True Power-On State) Operation

After the power-on time, t_{PO} , the device immediately generates an output voltage corresponding to the target feature opposite the device. It does so by comparing the existing level of the application magnetic gradient, B_{APP} , to the TPOS switching level, an internal threshold used to distinguish a tooth from a valley during TPOS operation (from power-on until the end of the Initial Calibration stage). If B_{APP} is less than the threshold, that target feature is evaluated as a valley, and if B_{APP} is greater, the feature is evaluated as a tooth.

Calibration Mode Operation

At power-on (simultaneous with TPOS operation) Calibration mode begins. Calibration mode is performed in two stages: the Initial Calibration stage, followed immediately by the TPOS to Running Mode Transition stage (see figure 7). After the second calibration stage, Running mode begins immediately.

In Calibration mode, the operating range of the application magnetic gradient, B_{APP} , is detected and evaluated, and then the ATS675 electronics are adapted for optimal output switching. Calibration is performed quickly, without reading the entire target, because the ATS675 applies the internal magnetic baseline.

Initial Calibration Stage During the Initial Calibration stage, TPOS operation controls device output switching while calibration starts. In this stage, the peak-detecting DACs acquire the application magnetic signal. Based on those results, the Automatic Gain Control (AGC) feature calculates the normalized Running mode switching range. This period is minimized, so swapping to the Running mode thresholds can occur as quickly as possible.

TPOS to Running Mode Transition Stage At the beginning of this stage, TPOS operation terminates, and throughout this stage the device automatically adjusts the output switching levels from the original preset switching level to the Running mode switchpoints. This transition takes place over one tooth, immediately swapping from TPOS to Running mode switchpoints.

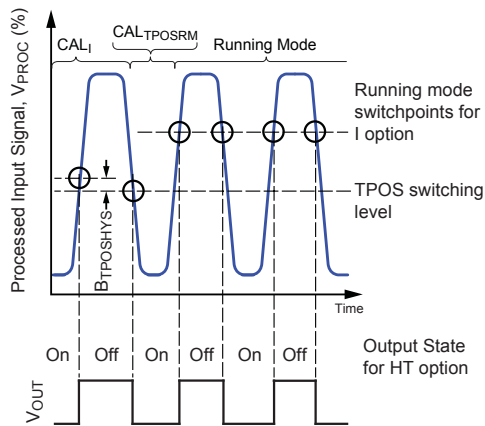

Figure 7. Calibration mode waveforms.

Running Mode Operation

Running mode begins immediately at the end of Calibration mode. During Running mode, switchpoints are established dynamically, based on the sensed application magnetic gradient, B_{APP} . To determine switchpoints, B_{APP} is normalized by the AGC feature, and processed to generate the internal processed signal, V_{PROC} . Two peak-detecting DACs track the V_{PROC} waveform, and the output switchpoints are established as percentages of the values held by the two DACs. Because the switchpoints are established dynamically as a percentage of the peak-to-peak signal, the effects of an application baseline shift are minimized.

Running Mode Switchpoints

The values used to define Running mode switchpoints are cal-

culated as a percentage of the peak-to-peak V_{PROC} . As shown in figure 11, this percentage is subtracted from the maximum V_{PROC} value, $V_{PROC}(high)$, a value corresponding to a minimum air gap, that is, at the most prominent target tooth. On the ATS675LSE, the switchpoints are referenced to approximately 30% of the peak-to-peak magnetic signal. This level closely corresponds to the mechanical target edges, resulting in optimal timing accuracy versus air gap.

Running Mode Hysteresis

The ATS675LSE uses an internal hysteresis method, switching at a consistent point on both rising and falling edges. When a target anomaly is encountered, the internal hysteresis thresholds provide immunity to false switching, as illustrated in figure 12.

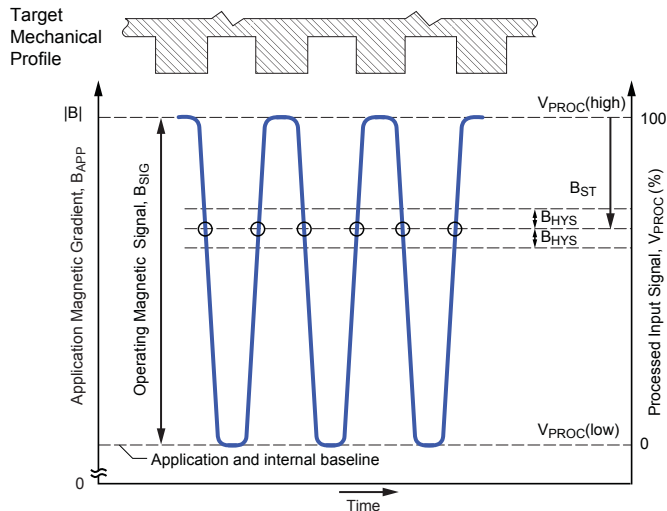

Figure 11. Switchpoints Level for Running Mode definition (switchpoints indicated by circles).

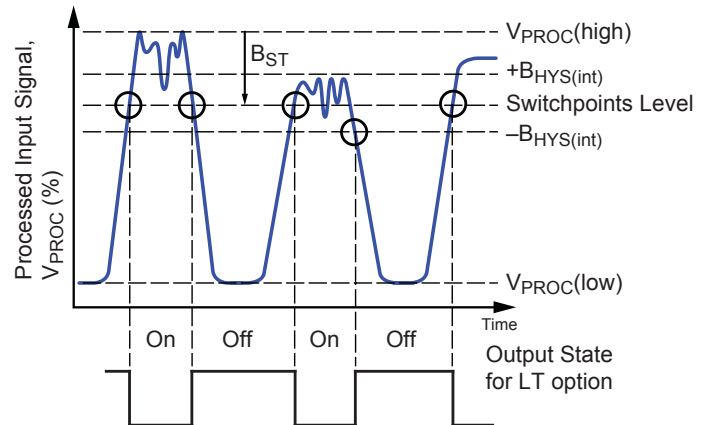

Figure 12. Running mode switching on anomalous peak (switchpoints indicated by circles).

Power Derating

The device must be operated below the maximum junction temperature of the device, $T_{J(max)}$. Under certain combinations of peak conditions, reliable operation may require derating supplied power or improving the heat dissipation properties of the application. This section presents a procedure for correlating factors affecting operating T_J . (Thermal data is also available on the Allegro MicroSystems website.)

The Package Thermal Resistance, $R_{\theta JA}$, is a figure of merit summarizing the ability of the application and the device to dissipate heat from the junction (die), through all paths to the ambient air. Its primary component is the Effective Thermal Conductivity, K , of the printed circuit board, including adjacent devices and traces. Radiation from the die through the device case, $R_{\theta JC}$, is relatively small component of $R_{\theta JA}$. Ambient air temperature, T_A , and air motion are significant external factors, damped by overmolding.

The effect of varying power levels (Power Dissipation, P_D), can be estimated. The following formulas represent the fundamental relationships used to estimate T_J , at P_D .

$$P_D = V_{IN} \times I_{IN} \quad (1)$$

$$\Delta T = P_D \times R_{\theta JA} \quad (2)$$

$$T_J = T_A + \Delta T \quad (3)$$

For example, given common conditions such as: $T_A = 25^\circ\text{C}$, $V_{CC} = 12\text{ V}$, $I_{CC} = 7\text{ mA}$, and $R_{\theta JA} = 77^\circ\text{C/W}$, then:

$$P_D = V_{CC} \times I_{CC} = 12\text{ V} \times 7\text{ mA} = 84\text{ mW}$$

$$\Delta T = P_D \times R_{\theta JA} = 84\text{ mW} \times 77^\circ\text{C/W} = 6.5^\circ\text{C}$$

$$T_J = T_A + \Delta T = 25^\circ\text{C} + 6.5^\circ\text{C} = 31.5^\circ\text{C}$$

A worst-case estimate, $P_{D(max)}$, represents the maximum allowable power level, without exceeding $T_{J(max)}$, at a selected $R_{\theta JA}$ and T_A .

Example: Reliability for V_{CC} at $T_A = 150^\circ\text{C}$.

Observe the worst-case ratings for the device, specifically: $R_{\theta JA} = 101^\circ\text{C/W}$, $T_{J(max)} = 165^\circ\text{C}$, $V_{CC(max)} = 24\text{ V}$, and $I_{CC(max)} = 10\text{ mA}$.

Calculate the maximum allowable power level, $P_D(max)$. First, invert equation 3:

$$\Delta T(max) = T_{J(max)} - T_A = 165^\circ\text{C} - 150^\circ\text{C} = 15^\circ\text{C}$$

This provides the allowable increase to T_J resulting from internal power dissipation.

Then, invert equation 2:

$$P_D(max) = \Delta T(max) \div R_{\theta JA} = 15^\circ\text{C} \div 101^\circ\text{C/W} = 148.5\text{ mW}$$

Finally, invert equation 1 with respect to voltage:

$$V_{CC(est)} = P_D(max) \div I_{CC(max)} = 148.5\text{ mW} \div 10\text{ mA} = 14.9\text{ V}$$

The result indicates that, at T_A , the application and device can dissipate adequate amounts of heat at voltages $\leq V_{CC(est)}$.

Compare $V_{CC(est)}$ to $V_{CC(max)}$. If $V_{CC(est)} \leq V_{CC(max)}$, then reliable operation between $V_{CC(est)}$ and $V_{CC(max)}$ requires enhanced $R_{\theta JA}$. If $V_{CC(est)} \geq V_{CC(max)}$, then operation between $V_{CC(est)}$ and $V_{CC(max)}$ is reliable under these conditions.

Package SE 4-Pin SIP

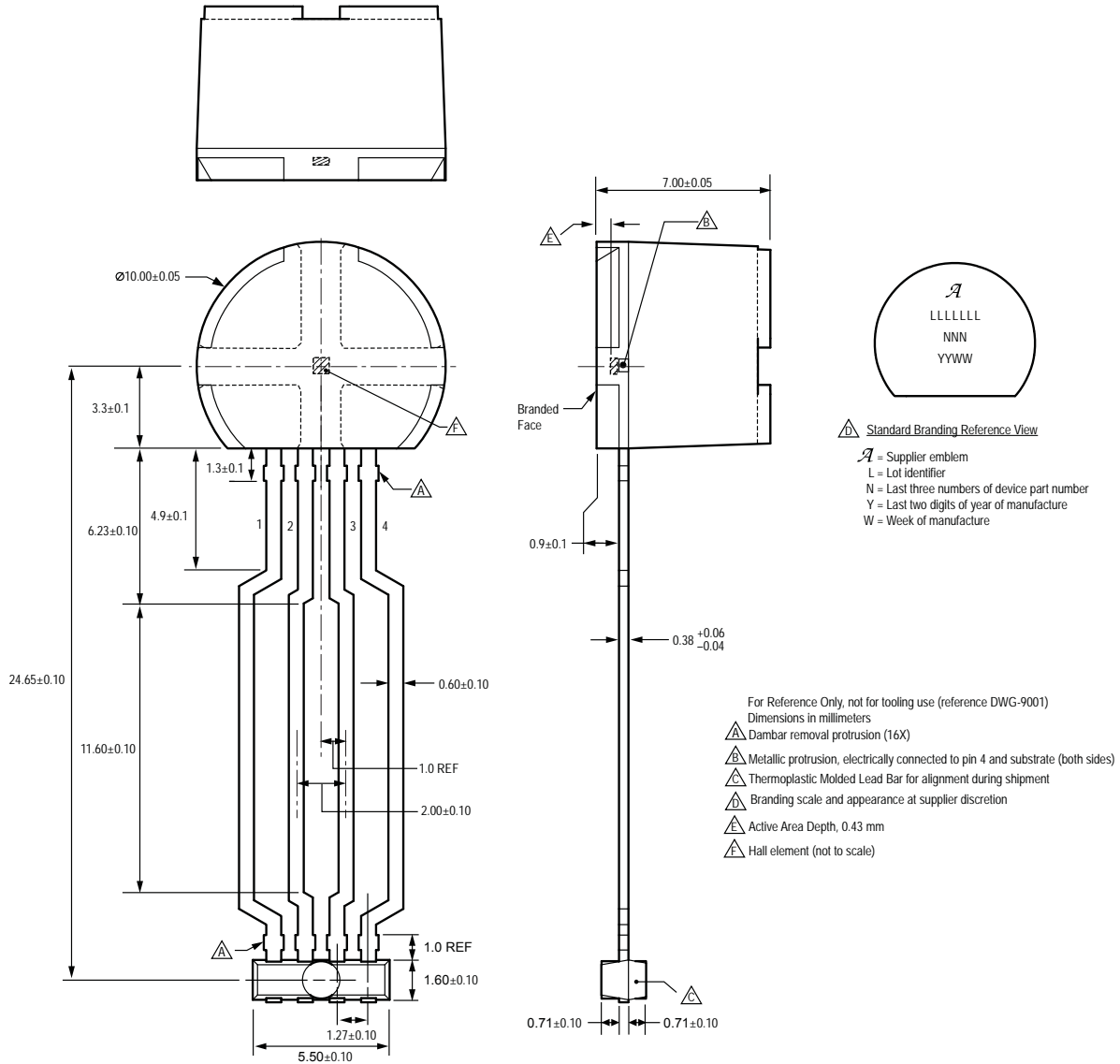

Copyright ©2008-2013, Allegro MicroSystems, LLC

Allegro MicroSystems, LLC reserves the right to make, from time to time, such departures from the detail specifications as may be required to permit improvements in the performance, reliability, or manufacturability of its products. Before placing an order, the user is cautioned to verify that the information being relied upon is current.

Allegro's products are not to be used in life support devices or systems, if a failure of an Allegro product can reasonably be expected to cause the failure of that life support device or system, or to affect the safety or effectiveness of that device or system.

The information included herein is believed to be accurate and reliable. However, Allegro MicroSystems, LLC assumes no responsibility for its use; nor for any infringement of patents or other rights of third parties which may result from its use.



For the latest version of this document, visit our website:

www.allegromicro.com



Looking for pricing, stock, or lifecycle information?

Click below to explore more details on WIN SOURCE:

-  [View AT675LSETN-LT-T on WIN SOURCE](#)
-  [Allegro MicroSystems, LLC Information](#)

Optimize Your Supply Chain with WIN SOURCE Solutions

-  Global Sourcing Solution
-  Obsolete Management
-  Cost Control Management
-  Shortage Management
-  Alternative Solution
-  Excess Inventory Management