



# THE DATASHEET OF LMH6555SQE/NOPB



## LMH6555 Low Distortion 1.2 GHz Differential Driver

Check for Samples: [LMH6555](#)

### FEATURES

- Typical Values unless Otherwise Specified.
- **-3 dB Bandwidth ( $V_{OUT} = 0.80 V_{PP}$ ) 1.2 GHz**
- **$\pm 0.5$  dB Gain Flatness ( $V_{OUT} = 0.80 V_{PP}$ ) 330 MHz**
- **Slew Rate 1300 V/ $\mu$ s**
- **2<sup>nd</sup>/3<sup>rd</sup> Harmonics (750 MHz) -53/-54 dBc**
- **Fixed Gain 13.7 dB**
- **Supply Current 120 mA**
- **Single Supply Operation 3.3V  $\pm 10\%$**
- **Adjustable Common-Mode Output Voltage**

### APPLICATIONS

- Differential ADC Driver
- Texas Instruments ADC081500/ ADC081000 – (Single or Dual) Driver
- Single Ended to Differential Converter
- Intermediate Frequency (IF) Amplifier
- Communication Receivers
- Oscilloscope Front End

### TYPICAL APPLICATION

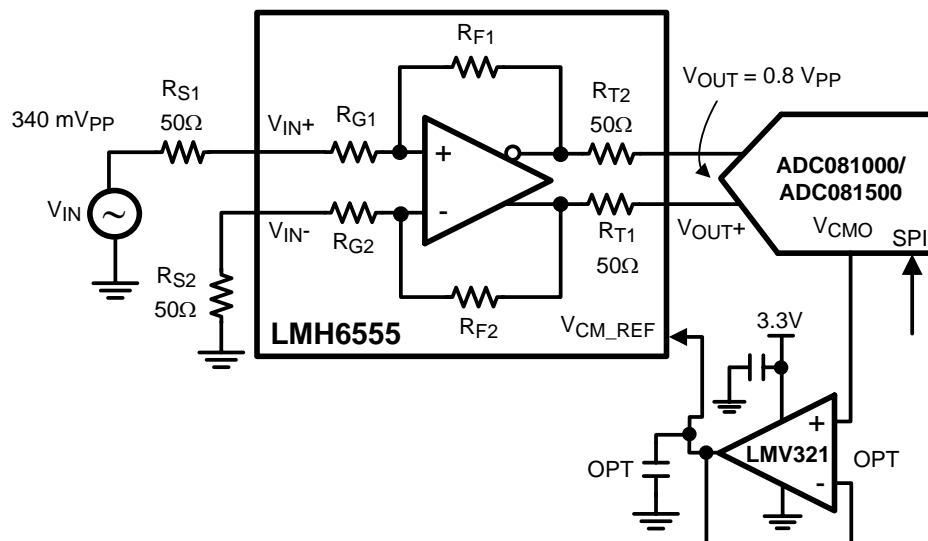

Figure 1. Single Ended to Differential Conversion

### DESCRIPTION

The LMH6555 is an ultra high speed differential line driver with 53 dB SFDR at 750 MHz. The LMH6555 features a fixed gain of 13.7 dB. An input to the device allows the output common mode voltage to be set independent of the input common mode voltage in order to simplify the interface to high speed differential input ADCs. A unique architecture allows the device to operate as a fully differential driver or as a single-ended to differential converter.

The outstanding linearity and drive capability (100 $\Omega$  differential load) of this device are a perfect match for driving high speed analog-to-digital converters. When combined with the ADC081000/ ADC081500 (single or dual ADC), the LMH6555 forms an excellent 8-bit data acquisition system with analog bandwidths exceeding 750 MHz.

The LMH6555 is offered in a space saving 16-pin WQFN package.



Please be aware that an important notice concerning availability, standard warranty, and use in critical applications of Texas Instruments semiconductor products and disclaimers thereto appears at the end of this data sheet.

All trademarks are the property of their respective owners.



These devices have limited built-in ESD protection. The leads should be shorted together or the device placed in conductive foam during storage or handling to prevent electrostatic damage to the MOS gates.

### ABSOLUTE MAXIMUM RATINGS <sup>(1)(2)</sup>

ESD Tolerance <sup>(3)</sup>	Human Body Model	2000V
	Machine Model	200V
$V_S$		4.2V
Output Short Circuit Duration(one pin to ground)		Infinite
Common Mode Input Voltage		-0.4V to 3V
Maximum Junction Temperature		+150°C
Storage Temperature Range		-65°C to +150°C
Soldering Information	Infrared or Convection (20 sec.)	235°C
	Wave Soldering (10 sec.)	260°C

- (1) Absolute Maximum Ratings indicate limits beyond which damage to the device may occur. Operating Ratings indicate conditions for which the device is intended to be functional, but specific performance is not ensured. For specifications, see the Electrical Characteristics tables.
- (2) If Military/Aerospace specified devices are required, please contact the Texas Instruments Sales Office/ Distributors for availability and specifications.
- (3) Human Body Model, applicable std. MIL-STD-883, Method 3015.7. Machine Model, applicable std. JESD22-A115-A (ESD MM std. of JEDEC) Field-Induced Charge-Device Model, applicable std. JESD22-C101-C (ESD FICDM std. of JEDEC).

### OPERATING RATINGS <sup>(1)</sup>

Temperature Range <sup>(2)</sup>		-40°C to +85°C
Supply Voltage Range		+3.3V ±10%
Package Thermal Resistance ( $\theta_{JA}$ ) <sup>(2)</sup>	16-Pin WQFN	65°C/W

- (1) Absolute Maximum Ratings indicate limits beyond which damage to the device may occur. Operating Ratings indicate conditions for which the device is intended to be functional, but specific performance is not ensured. For specifications, see the Electrical Characteristics tables.
- (2) The maximum power dissipation is a function of  $T_{J(MAX)}$ ,  $\theta_{JA}$  and  $T_A$ . The maximum allowable power dissipation at any ambient temperature is  $P_D = (T_{J(MAX)} - T_A) / \theta_{JA}$ . All numbers apply for package soldered directly into a 2 layer PC board with zero air flow. Package should be soldered unto a 6.8 mm<sup>2</sup> copper area as shown in the "recommended land pattern" shown in the package drawing.

### 3.3V ELECTRICAL CHARACTERISTICS <sup>(1)</sup>

Unless otherwise specified, all limits are specified for  $T_A = 25^\circ\text{C}$ ,  $V_{CM\_REF} = 1.2\text{V}$ , both inputs tied to  $0.3\text{V}$  through  $50\Omega$  ( $R_{S1}$  &  $R_{S2}$ ) each <sup>(2)</sup>,  $V_S = 3.3\text{V}$ ,  $R_L = 100\Omega$  differential,  $V_{OUT} = 0.8 V_{PP}$ . See [DEFINITION OF TERMS AND SPECIFICATIONS \(ALPHABETICAL ORDER\)](#) for definition of terms used throughout the datasheet. **Boldface** limits apply at the temperature extremes.

Symbol	Parameter	Conditions	Min <sup>(3)</sup>	Typ <sup>(4)</sup>	Max <sup>(3)</sup>	Units
<b>AC/DC Performance</b>						
SSBW	-3 dB Bandwidth	$V_{OUT} = 0.25 V_{PP}$		1200		MHz
LSBW		$V_{OUT} = 0.8 V_{PP}$		1200		
Peak	Peaking	$V_{OUT} = 0.8 V_{PP}$		1.4		dB
GF_0.1 dB	Gain Flatness	$\pm 0.1$ dB		180		MHz
GF_0.5 dB		$\pm 0.5$ dB		330		
Ph_Delta	Phase Delta	Output Differential Phase Difference $f \leq 1.2$ GHz		$< \pm 0.8$		deg
Lin_Ph	Linear Phase Deviation	Each Output $f \leq 2$ GHz		$< \pm 30$		deg
GD	Group Delay	Each Output $f \leq 2$ GHz		0.75		ns
P_1 dB	1 dB Compression	1 GHz		1		$V_{PP}$
TRS/TRL	Rise/ Fall Time	$V_{OUT} = 0.2 V_{PP}$ Each Output		320		pS
OS	Overshoot	$V_{OUT} = 0.2 V_{PP}$ Each Output		14		%
SR	Slew Rate	0.8V Step, 10% to 90%, <sup>(5)</sup>		1300		V/ $\mu$ s
$t_s$	Settling Time	$\pm 1\%$		2.2		ns
$A_{V\_DIFF}$	Insertion Gain ( $ S_{21} $ )	$DC, \frac{\Delta V_{OUT}}{\Delta V_{IN}}$	13.2	13.7	14.0	dB
			<b>13.1</b>		<b>14.1</b>	
TC $A_{V\_DIFF}$	Temperature Coefficient of Insertion Gain			-0.9		mdB/ $^\circ\text{C}$
$\Delta A_{V\_DIFF1}$	Insertion Gain Variation with $V_{CM\_REF}$	$V_{CM\_REF}$ Input Varied from 0.95V to 1.45, $V_{OUT} = 0.8 V_{PP}$		-0.04	$\pm 0.50$ <b><math>\pm 0.58</math></b>	dB
$\Delta A_{V\_DIFF2}$	Insertion Gain Variation with $V_{I\_CM}$	$-0.3 \leq V_{I\_CM} \leq 2.0\text{V}$		$\pm 0.03$	$\pm 0.48$ <b><math>\pm 0.55</math></b>	dB
<b>Distortion And Noise Response</b>						
HD2_L	2 <sup>nd</sup> Harmonic Distortion	250 MHz <sup>(6)</sup>		-60		dBc
HD2_M		500 MHz <sup>(6)</sup>		-62		
HD2_H		750 MHz <sup>(6)</sup>		-53		
HD3_L	3 <sup>rd</sup> Harmonic Distortion	250 MHz <sup>(6)</sup>		-67		dBc
HD3_M		500 MHz <sup>(6)</sup>		-61		
HD3_H		750 MHz <sup>(6)</sup>		-54		
OIP3	Output 3 <sup>rd</sup> Order Intermodulation Intercept	$f = 1$ GHz $P_{OUT}$ (Each Tone) $\leq -8.5$ dBm <sup>(6)(7)</sup>		27.5		dBm
OIM3	3 <sup>rd</sup> Order Intermodulation Distortion	$f = 1$ GHz $P_{OUT}$ (Each Tone) $= -6$ dBm <sup>(6)(7)</sup>		-67		dBc
$e_{no}$	Output Referred Voltage Noise	$\geq 1$ MHz		19		nV/ $\sqrt{\text{Hz}}$

- (1) Electrical Table values apply only for factory testing conditions at the temperature indicated. Factory testing conditions result in very limited self-heating of the device such that  $T_J = T_A$ . No specification of parametric performance is indicated in the electrical tables under conditions of internal self-heating where  $T_J > T_A$ .
- (2) Quiescent device common mode input voltage is  $0.3\text{V}$ .
- (3) Limits are 100% production tested at  $25^\circ\text{C}$ . Limits over the operating temperature range are specified through correlation using Statistical Quality Control (SQC) methods.
- (4) Typical values represent the most likely parametric norm as determined at the time of characterization. Actual typical values may vary over time and will also depend on the application and configuration. The typical values are not tested and are not ensured on shipped production material.
- (5) Slew Rate is the average of the rising and falling edges.
- (6) Distortion data taken under single ended input condition.
- (7)  $0$  dBm =  $894$  mV $_{PP}$  across  $100\Omega$  differential load

### 3.3V ELECTRICAL CHARACTERISTICS <sup>(1)</sup> (continued)

Unless otherwise specified, all limits are specified for  $T_A = 25^\circ\text{C}$ ,  $V_{\text{CM\_REF}} = 1.2\text{V}$ , both inputs tied to  $0.3\text{V}$  through  $50\Omega$  ( $R_{S1}$  &  $R_{S2}$ ) each <sup>(2)</sup>,  $V_S = 3.3\text{V}$ ,  $R_L = 100\Omega$  differential,  $V_{\text{OUT}} = 0.8 V_{\text{PP}}$ . See [DEFINITION OF TERMS AND SPECIFICATIONS \(ALPHABETICAL ORDER\)](#) for definition of terms used throughout the datasheet. **Boldface** limits apply at the temperature extremes.

Symbol	Parameter	Conditions	Min <sup>(3)</sup>	Typ <sup>(4)</sup>	Max <sup>(3)</sup>	Units
NF	Noise Figure	Relative to a Differential Input $\geq 10\text{ MHz}$		15.0		dB
<b>Input Characteristics</b>						
$R_{\text{IN}}$	CM Input Resistance	Each Input to Ground	45	50	55	$\Omega$
$R_{\text{IN\_DIFF}}$	Differential Input Resistance	Differential	66	78	100	$\Omega$
$C_{\text{IN}}$	Input Capacitance	Each Input to GND		0.3		pF
CMRR	Common Mode Rejection Ratio	$-0.3 \leq \text{CMVR} \leq 2.0\text{V}$	40 <b>36</b>	68		dB
<b>Output Characteristics</b>						
$V_{\text{OOS}}$	Output Offset Voltage	Differential Mode		15	$\pm 50$ <b><math>\pm 55</math></b>	mV
$\text{TC}_{V_{\text{OOS}}}$	Output Offset Voltage Average Drift	<sup>(8)</sup>		$\pm 100$		$\mu\text{V}/^\circ\text{C}$
$R_{\text{O}}$	Output Resistance	$R_{T1}$ and $R_{T2}$	43	50	53	$\Omega$
BAL_Error_DC	Output Gain Balance Error	$\text{DC, } \frac{\Delta V_{\text{O\_CM}}}{\Delta V_{\text{OUT}}}$		-57	-38	dB
BAL_Error_AC				-48		
BAL_Error_AC_Phase	Output Phase Balance Error	$f = 750\text{ MHz, } V_{\text{OUT}^+} - V_{\text{OUT}^-}$ Phase		$\pm 0.6$		deg
$ \Delta V_{\text{O\_CM}}/\Delta V_{\text{I\_CM}} $	Output Common Mode Gain	DC		-26	-22 <b>-21</b>	dB
<b><math>V_{\text{CM\_REF}}</math> Characteristics</b>						
$V_{\text{OS\_CM}}$	Output CM Offset Voltage	$V_{\text{OS\_CM}} = V_{\text{O\_CM}} - V_{\text{CM\_REF}}$		-4	$\pm 60$ <b><math>\pm 85</math></b>	mV
$\text{TC}_{V_{\text{OS\_CM}}}$	CM Offset Voltage Temp Coefficient			-0.2		$\text{mV}/^\circ\text{C}$
$I_{\text{B\_CM}}$	$V_{\text{CM\_REF}}$ Bias Current	$0.95\text{V} \leq V_{\text{CM\_REF}} \leq 1.45\text{V}$ <sup>(9)</sup>		-25	$\pm 390$ <b><math>\pm 415</math></b>	$\mu\text{A}$
$R_{\text{IN\_CM}}$	$V_{\text{CM\_REF}}$ Input Resistance		3.5	5.8		k $\Omega$
Gain_ $V_{\text{CM\_REF}}$	$V_{\text{CM\_REF}}$ Input Gain to Output	$\Delta V_{\text{O\_CM}}/\Delta V_{\text{CM\_REF}}$	0.97	0.99	1.00	V/V
<b>Power Supply</b>						
$I_{\text{S}}$	Supply Current	$R_{S1}$ & $R_{S2}$ Open <sup>(10)</sup>		120	150 <b>156</b>	mA
PSRR	Differential Power Supply Rejection Ratio	DC, $\Delta V_S = \pm 0.3\text{V}$ , $\Delta V_{\text{OUT}}/\Delta V_S$	-27 <b>-25</b>	-44		dB
PSRR_CM	Common Mode PSRR	DC, $\Delta V_S = \pm 0.3\text{V}$ , $\Delta V_{\text{O\_CM}}/\Delta V_S$	-29 <b>-27</b>	-39		dB

(8) Drift determined by dividing the change in parameter at temperature extremes by the total temperature change.

(9) Positive current is current flowing into the device.

(10) Total supply current is affected by the input voltages connected through  $R_{S1}$  and  $R_{S2}$ . Supply current tested with input removed.

CONNECTION DIAGRAM

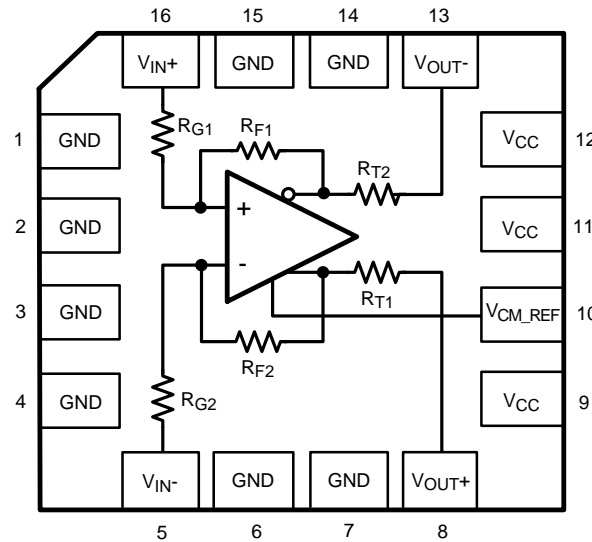

Figure 2. 16-Pin WQFN

DEFINITION OF TERMS AND SPECIFICATIONS (ALPHABETICAL ORDER)

Unless otherwise specified,  $V_{CM\_REF} = 1.2V$

1.	$A_{V\_CM}$ (dB)	Change in the differential output voltage ( $\Delta V_{OUT}$ ) with respect to the change in input common mode voltage ( $\Delta V_{I\_CM}$ )
2.	$A_{V\_DIFF}$ (dB)	Insertion gain from a single ended 50 $\Omega$ (or 100 $\Omega$ differential) source to the differential output ( $\Delta V_{OUT}$ )
3.	$\Delta A_{V\_DIFF}$ (dB)	Variation in insertion gain ( $A_{V\_DIFF}$ )
4.	BAL_ERR_DC & BAL_ERR_AC	Balance Error. See $\left( \frac{\Delta V_{O\_CM}}{\Delta V_{OUT}} \right)$
5.	CM	Common Mode
6.	CMRR (dB)	Common Mode rejection defined as: $A_{V\_DIFF}$ (dB) - $A_{V\_CM}$ (dB)
7.	CMVR (V)	Range of input common mode voltage ( $V_{I\_CM}$ )
8.	Gain_ $V_{CM\_REF}$ (V/V)	Variation in output common mode voltage ( $\Delta V_{O\_CM}$ ) with respect to change in $V_{CM\_REF}$ input ( $\Delta V_{CM\_REF}$ ) with maximum differential output
9.	PSRR (dB)	Differential output change ( $\Delta V_{OUT}$ ) with respect to the power supply voltage change ( $\Delta V_S$ ) with nominal differential output
10.	PSRR_CM (dB)	Output common mode voltage change ( $\Delta V_{O\_CM}$ ) with respect to the change in the power supply voltage ( $\Delta V_S$ )
11.	$R_{IN}$ ( $\Omega$ )	Single ended input impedance to ground
12.	$R_{IN\_DIFF}$ ( $\Omega$ )	Differential input impedance
13.	$R_L$ ( $\Omega$ )	Differential output load
14.	$R_O$ ( $\Omega$ )	Device output impedance equivalent to $R_{T1}$ & $R_{T2}$
15.	$R_{S1}, R_{S2}$ ( $\Omega$ )	Source impedance to $V_{IN}^+$ and $V_{IN}^-$ respectively
16.	$R_{T1}, R_{T2}$ ( $\Omega$ )	Output impedance looking into each output
17.	$V_{CM\_REF}$ (V)	Device input pin which controls output common mode
18.	$\Delta V_{CM\_REF}$ (V)	Change in the $V_{CM\_REF}$ input
19.	$V_{I\_CM}$ (V)	DC average of the inputs ( $V_{IN}^+, V_{IN}^-$ ) or the common mode signal at those same input pins
20.	$\Delta V_{I\_CM}$ (V)	Variation in input common mode voltage ( $V_{I\_CM}$ )

21.	$V_{IN}^+, V_{IN}^-$ (V)	Device input pin voltages
22.	$\Delta V_{IN}$ (V)	Terminated (50 $\Omega$ for single ended and 100 $\Omega$ for differential) generator voltage
23.	$V_{O\_CM}$ (V)	Output common mode voltage (DC average of $V_{OUT}^+$ and $V_{OUT}^-$ )
24.	$\Delta V_{O\_CM}$ (V)	Variation in output common mode voltage ( $V_{O\_CM}$ )
25.	$\frac{\Delta V_{O\_CM}}{\Delta V_{OUT}}$ (dB)	Balance Error. Measure of the output swing balance of $V_{OUT}^+$ and $V_{OUT}^-$ , as reflected on the output common mode voltage ( $V_{O\_CM}$ ), relative to the differential output swing ( $V_{OUT}$ ). Calculated as output common mode voltage change ( $\Delta V_{O\_CM}$ ) divided into the output differential voltage change ( $\Delta V_{OUT}$ which is nominally around 800 mV <sub>PP</sub> )
26.	$\frac{V_{O\_CM}}{V_{OUT}}$ (dB)	AC version of the DC balance error $\left(\frac{\Delta V_{O\_CM}}{\Delta V_{OUT}}\right)$ test
27.	$V_{OOS}$ (V)	DC Offset Voltage. Differential output voltage measured with both inputs grounded through 50 $\Omega$
28.	$V_{OS\_CM}$ (V)	Difference between the output common mode voltage ( $V_{O\_CM}$ ) and the voltage on the $V_{CM\_REF}$ input, for the allowable $V_{CM\_REF}$ range
29.	$V_{OUT}$ (V)	Differential Output Voltage ( $V_{OUT}^+ - V_{OUT}^-$ ) (Corrected for DC offset ( $V_{OOS}$ ))
30.	$\Delta V_{OUT}$ (V)	Change in the differential output voltage (Corrected for DC offset ( $V_{OOS}$ ))
31.	$V_{OUT}^+, V_{OUT}^-$ (V)	Device output pin voltages
32.	$V_S$ (V)	Supply Voltage ( $V^+ - V^-$ )
33.	$\Delta V_S$ (V)	Change in $V_{CC}$ supply voltage

### TYPICAL PERFORMANCE CHARACTERISTICS

Unless otherwise specified,  $R_{S1} = R_{S2} = 50\Omega$ ,  $V_S = 3.3V$ ,  $R_L = 100\Omega$  differential,  $V_{OUT} = 0.8 V_{PP}$ . See [DEFINITION OF TERMS AND SPECIFICATIONS \(ALPHABETICAL ORDER\)](#) for definition of terms used throughout the datasheet.

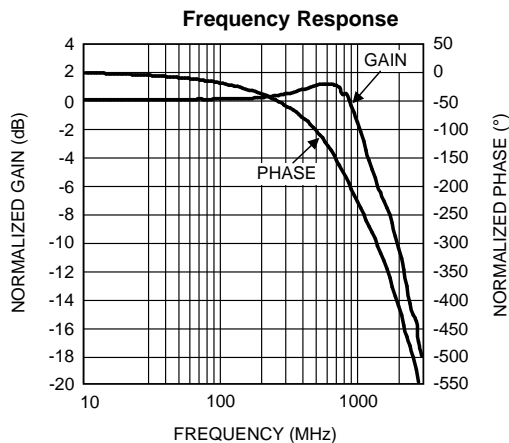

Figure 3.

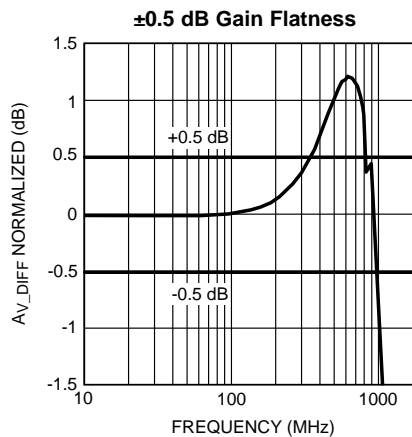

Figure 4.

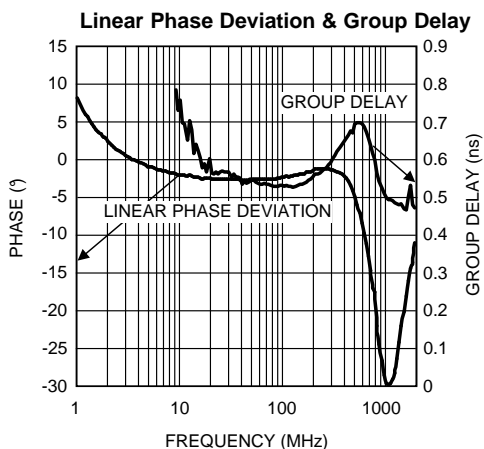

Figure 5.

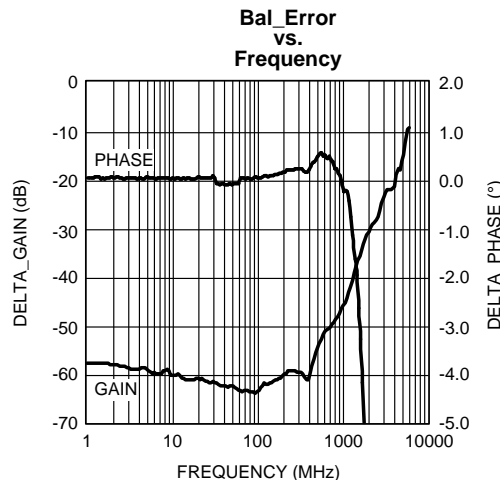

Figure 6.

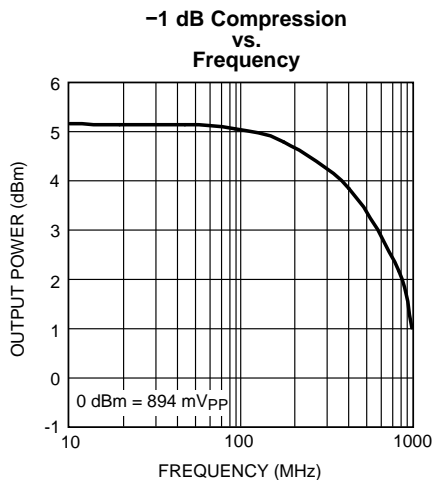

Figure 7.

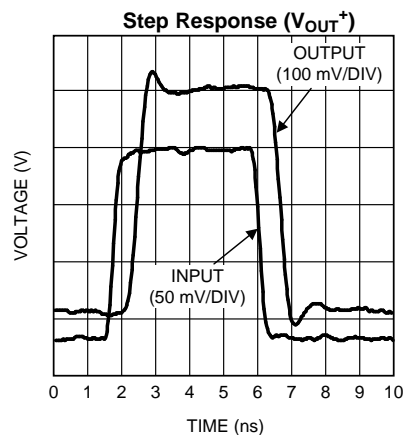

Figure 8.

**TYPICAL PERFORMANCE CHARACTERISTICS (continued)**

Unless otherwise specified,  $R_{S1} = R_{S2} = 50\Omega$ ,  $V_S = 3.3V$ ,  $R_L = 100\Omega$  differential,  $V_{OUT} = 0.8 V_{PP}$ . See [DEFINITION OF TERMS AND SPECIFICATIONS \(ALPHABETICAL ORDER\)](#) for definition of terms used throughout the datasheet.

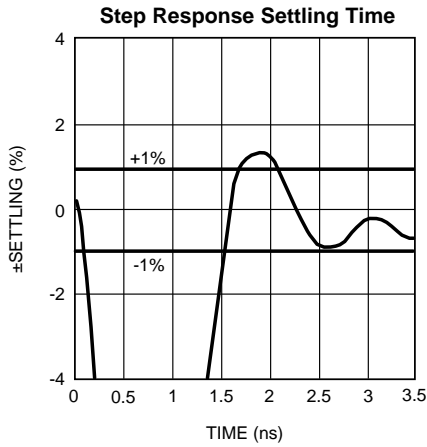

Figure 9.

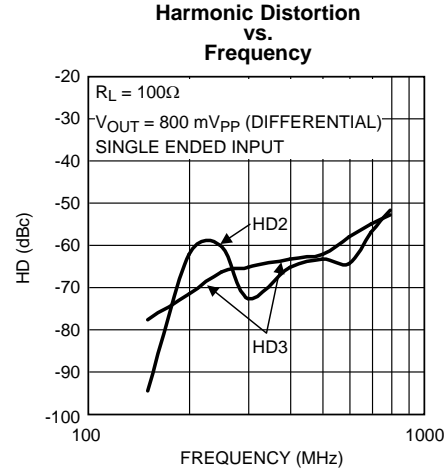

Figure 10.

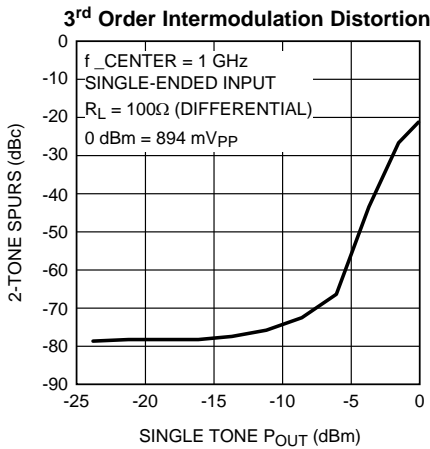

Figure 11.

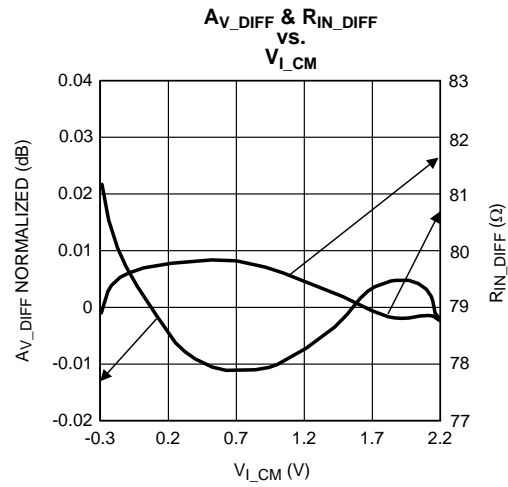

Figure 12.

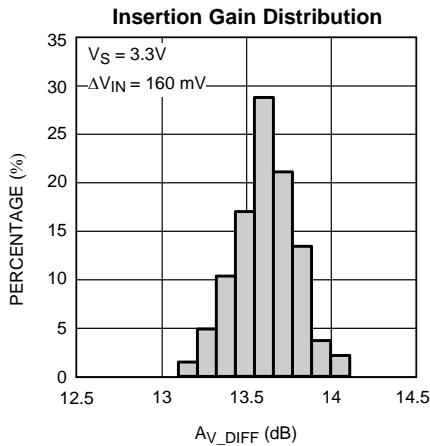

Figure 13.

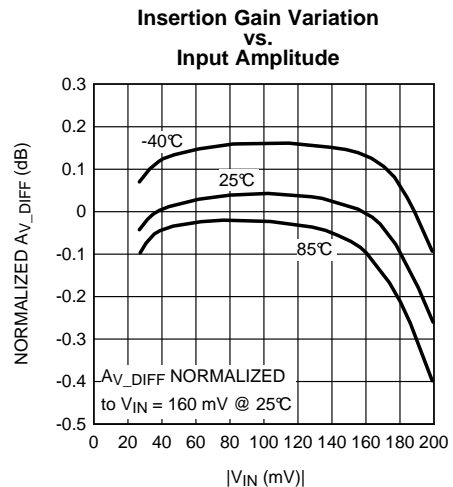

Figure 14.

**TYPICAL PERFORMANCE CHARACTERISTICS (continued)**

Unless otherwise specified,  $R_{S1} = R_{S2} = 50\Omega$ ,  $V_S = 3.3V$ ,  $R_L = 100\Omega$  differential,  $V_{OUT} = 0.8 V_{PP}$ . See [DEFINITION OF TERMS AND SPECIFICATIONS \(ALPHABETICAL ORDER\)](#) for definition of terms used throughout the datasheet.

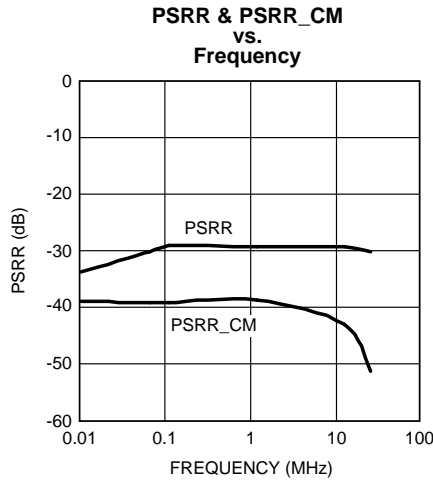

Figure 15.

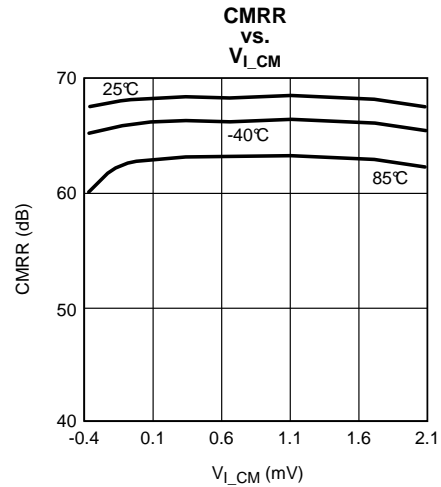

Figure 16.

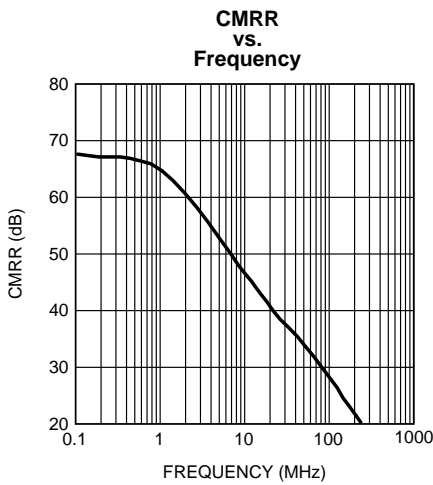

Figure 17.

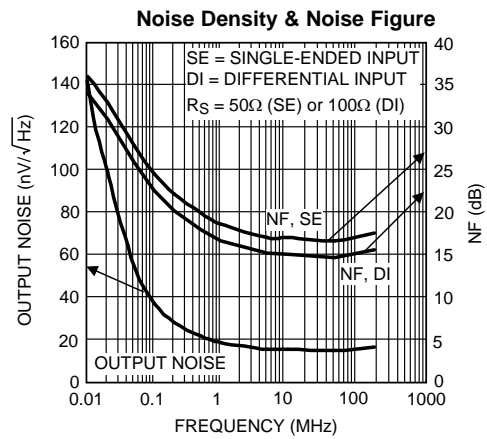

Figure 18.

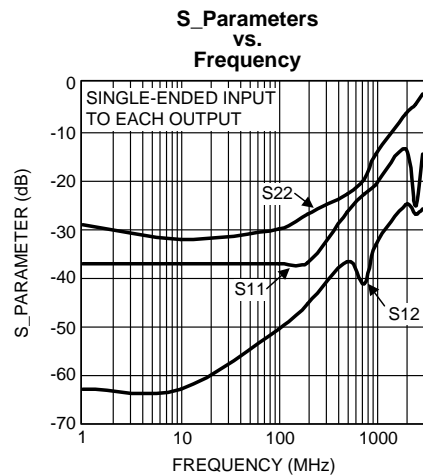

Figure 19.

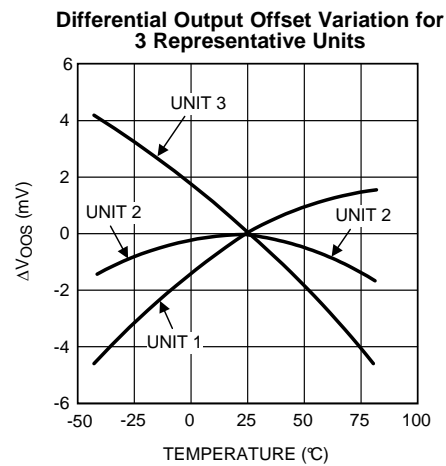
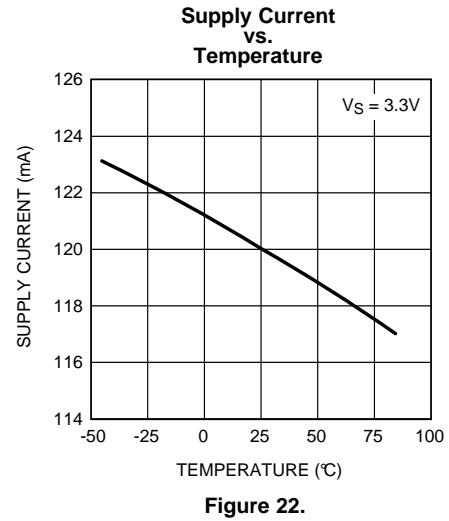
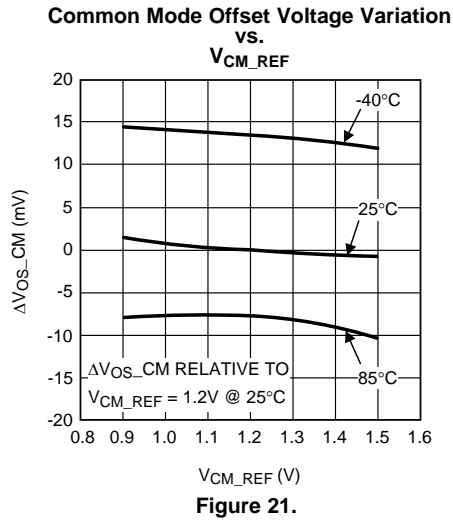

Figure 20.

**TYPICAL PERFORMANCE CHARACTERISTICS (continued)**

Unless otherwise specified,  $R_{S1} = R_{S2} = 50\Omega$ ,  $V_S = 3.3V$ ,  $R_L = 100\Omega$  differential,  $V_{OUT} = 0.8 V_{PP}$ . See [DEFINITION OF TERMS AND SPECIFICATIONS \(ALPHABETICAL ORDER\)](#) for definition of terms used throughout the datasheet.



## APPLICATION INFORMATION

See [DEFINITION OF TERMS AND SPECIFICATIONS \(ALPHABETICAL ORDER\)](#) for definition of terms used.

### GENERAL

The LMH6555 consists of three individual amplifiers:

1.  $V_{OUT}^+$  driver
2.  $V_{OUT}^-$  driver
3. The common mode amplifier

Being a differential amplifier, the LMH6555 will not respond to the common mode input (as long as it is within its input common mode range) and instead the output common mode is forced by the built-in common mode amplifier with  $V_{CM\_REF}$  as its input. As shown, in [Figure 23](#) below, the  $V_{CMO}$  output of most differential high speed ADC's is tied to the  $V_{CM\_REF}$  input of the LMH6555 for direct output common mode control. In some cases, the output drive capability of the ADC  $V_{CMO}$  output may need an external buffer, as shown, to increase its current capability in order to drive the  $V_{CM\_REF}$  pin. The [Electrical Characteristics Table](#) shows the gain ( $Gain_{V_{CM\_REF}}$ ) and the offset ( $V_{OS\_CM}$ ) from the  $V_{CM\_REF}$  to the device output common mode.

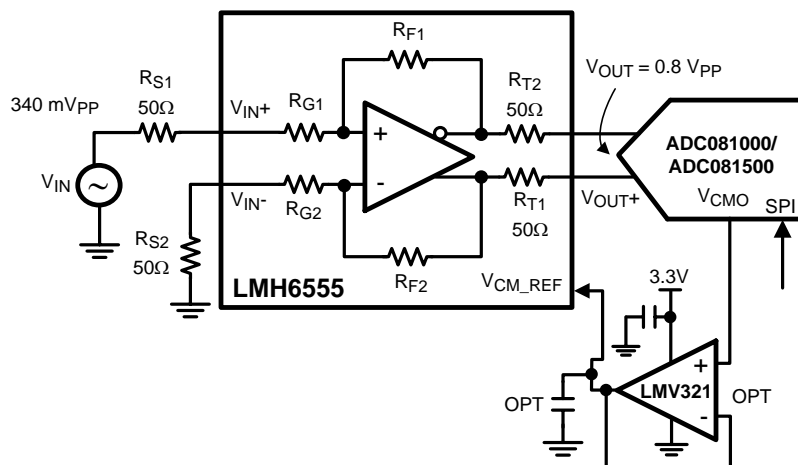

**Figure 23. Single Ended to Differential Conversion**

The single ended input and output impedances of the LMH6555 I/O pins are close to  $50\Omega$  as specified in [Electrical Characteristics Table](#) ( $R_{IN}$  and  $R_O$ ). With differential input drive, the differential input impedance ( $R_{IN\_DIFF}$ ) is close to  $78\Omega$ .

The device nominal input common mode voltage ( $V_{I\_CM}$ ) is close to  $0.3V$  when  $R_{S1}$  and  $R_{S2}$  of [Figure 23](#) are open. Thus, the input source will experience a DC current with  $0V$  input. Because of this, the differential output offset voltage is influenced by the matching between  $R_{S1}$  and  $R_{S2}$ . So, in a single ended input condition, if the signal source is AC coupled to one input, the undriven input needs to also be AC coupled in order to cancel the output offset voltage ( $V_{OOS}$ ).

In applications where low output offset is required, it is possible to inject some current to the appropriate input ( $V_{IN}^+$  or  $V_{IN}^-$ ) as an effective method of trimming the output offset voltage of the LMH6555. This is explained later in this document. The nominal value of  $R_{S1}$  and  $R_{S2}$  will also affect the insertion gain ( $A_{V\_DIFF}$ ). The LMH6555 can also be used with the input AC coupled through equal valued DC blocking capacitors ( $C$ ) in series with  $V_{IN}^+$  and  $V_{IN}^-$ . In this case, the coupling capacitors need to be large enough to not block the low frequency content. The lower cutoff frequency will be  $1/(\pi R_{EQ} C)$  Hz with  $R_{EQ} = R_{S1} + R_{S2} + R_{IN\_DIFF}$  where  $R_{IN\_DIFF} \approx 78\Omega$ .

The single ended output impedance of the LMH6555 is  $50\Omega$ . The LMH6555 [Electrical Characteristics](#) shows the device performance with  $100\Omega$  differential output load, as would be the case if a device such as the ADC081000/ADC081500 (single/ dual ADC) were being driven.

## CIRCUIT ANALYSIS

Figure 24 shows the block diagram of the LMH6555.

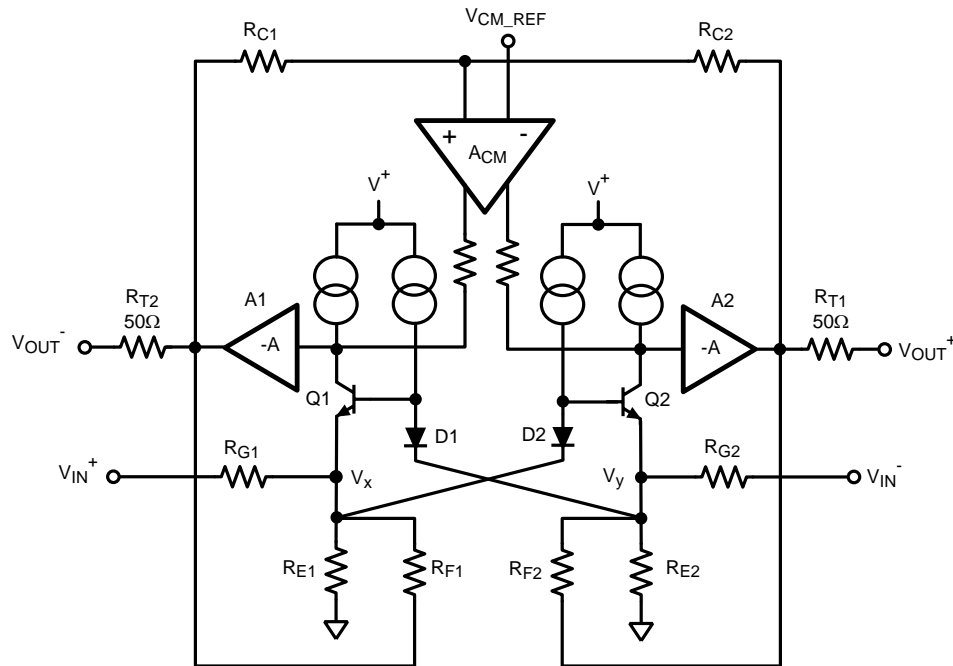

$$\begin{aligned}
 R_{G1} &= R_{G2} = R_G = 39\Omega \\
 R_{E1} &= R_{E2} = R_E = 25\Omega \\
 R_{F1} &= R_{F2} = R_F = 430\Omega \\
 I_{CQ1} &= I_{CQ2} = 12.6 \text{ mA}
 \end{aligned}$$

**Figure 24. Block Diagram**

The differential input stage consists of cross-coupled common base bipolar NPN stages, Q1 and Q2. These stages give the device its differential input characteristic. The internal loop gain from  $V_x$  and  $V_y$  internal nodes (Q1 and Q2 emitters) to the output is large, such that these nodes act as a virtual ground. The cross-coupling will ensure that these nodes are at the same voltage as long as the amplifier is operating within its normal range. Output common mode voltage is enforced through the action of "A<sub>CM</sub>" which servos the output common mode to the "V<sub>CM\_REF</sub>" input voltage.

**The discussion that follows, provides the formulas needed to analyze single ended and differential input applications. For a more detailed explanation including derivations, please see [Appendix](#) at the end of the datasheet.**

## SINGLE-ENDED INPUT

The following is the procedure for determining the device operating conditions for single ended input applications. This example will use the schematic shown in [Figure 25](#).

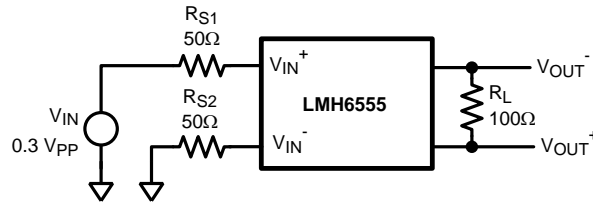

**Figure 25. Single-Ended Input Drive**

1. Determine the driven input's ( $V_{IN+}$  or  $V_{IN-}$ ) swing knowing that each input common mode impedance to ground ( $R_{IN}$ ) is  $50\Omega$ :

$$V_{IN+} \text{ (or } V_{IN-}) = V_{IN} \cdot R_{IN}/(R_{IN} + R_S) \quad (1)$$

For [Figure 25](#):

$$V_{IN+} = 0.3 \text{ V}_{PP} \cdot 50/(50+50) = 0.15 \text{ V}_{PP} \quad (2)$$

2. Calculate  $V_{OUT}$  knowing the Insertion Gain ( $A_{V\_DIFF}$ ):

$$V_{OUT} = (V_{IN}/2) \cdot A_{V\_DIFF}$$

$$A_{V\_DIFF} = 2 \cdot R_F / (2R_S + R_{IN\_DIFF})$$

where

- $R_F = 430\Omega$
- $R_{IN\_DIFF} = 78\Omega$

For [Figure 25](#):

$$R_S = 50\Omega \rightarrow A_{V\_DIFF} = 4.83 \text{ V/V}$$

$$V_{OUT} = (0.3 \text{ V}_{PP}/2) \cdot 4.83 \text{ V/V} = 724.5 \text{ mV}_{PP} \quad (3)$$

3. Determine the peak-to-peak differential current ( $I_{IN\_DIFF}$ ) through the device's differential input impedance ( $R_{IN\_DIFF}$ ) which would result in the  $V_{OUT}$  calculated in step 2:

$$I_{IN\_DIFF} = V_{OUT} / R_F \quad (4)$$

For [Figure 25](#):

$$I_{IN\_DIFF} = 724.5 \text{ mV}_{PP} / 430\Omega = 1.685 \text{ mA}_{PP} \quad (5)$$

4. Determine the swing across the input terminals ( $V_{IN\_DIFF}$ ) which would give rise to the  $I_{IN\_DIFF}$  calculated in step 3 above.

$$V_{IN\_DIFF} = I_{IN\_DIFF} \cdot R_{IN\_DIFF} \quad (6)$$

For [Figure 25](#):

$$V_{IN\_DIFF} = 1.685 \text{ mA}_{PP} \cdot 78\Omega = 131.4 \text{ mV}_{PP} \quad (7)$$

5. Calculate the undriven input's swing, based on  $V_{IN\_DIFF}$  determined in step 4 and  $V_{IN+}$  calculated in step 1:

$$V_{IN-} = V_{IN+} - V_{IN\_DIFF} \quad (8)$$

For [Figure 25](#):

$$V_{IN-} = 150 \text{ mV}_{PP} - 131.4 \text{ mV}_{PP} = 18.6 \text{ mV}_{PP} \quad (10)$$

6. Determine the DC average of the two inputs ( $V_{L\_CM}$ ) by using the following expression:

$$V_{L\_CM} = 12.6 \text{ mA} \cdot R_E \cdot R_S / (R_S + R_G + R_E)$$

where

- $R_E = 25\Omega$
- $R_G = 39\Omega$  (both internal to the LMH6555)

For [Figure 25](#)

(11)

$$R_S = 50\Omega \rightarrow V_{L\_CM} = 15.75 / (R_S + 64)$$

$$V_{L\_CM} = 15.75 / (50+64) = 138.2 \text{ mV}$$

(12)

The values determined with the procedure outlined here are shown in [Figure 26](#).

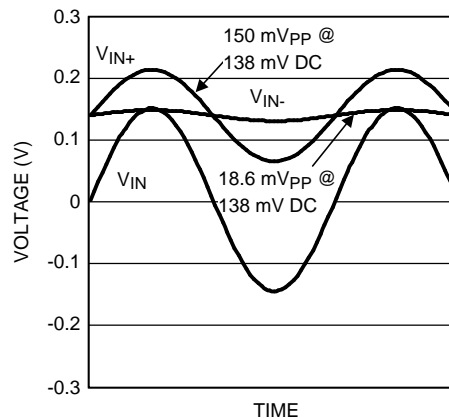

**Figure 26. Input Voltage for [Single-Ended Input Drive Schematic](#)**

## DIFFERENTIAL INPUT

The following is the procedure for determining the device operating conditions for differential input applications using the [Figure 27](#) schematic as an example.

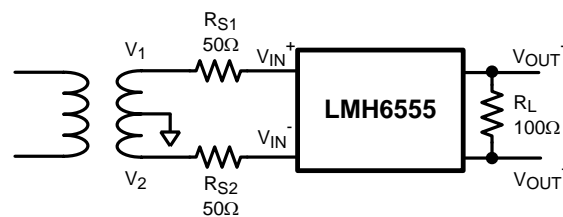

Assuming transformer secondary,  $V_{IN}$ , of 300 mV<sub>PP</sub>

**Figure 27. Differential Input Drive**

1. Calculate the swing across the input terminals ( $V_{IN\_DIFF}$ ) by considering the voltage division from the differential source ( $V_{IN}$ ) to the LMH6555 input terminals with differential input impedance  $R_{IN\_DIFF}$ :

$$V_{IN\_DIFF} = V_{IN} \cdot R_{IN\_DIFF} / (2R_S + R_{IN\_DIFF}) \quad (13)$$

For [Figure 27](#):

$$V_{IN\_DIFF} = 300 \text{ mV}_{PP} \cdot 78 / (100 + 78) = 131.5 \text{ mV}_{PP} \quad (14)$$

2. Calculate each input pin swing to be ½ the swing determined in step 1:

$$V_{IN+} = V_{IN-} = V_{IN\_DIFF} / 2 \quad (15)$$

For Figure 27

$$V_{IN+} = V_{IN-} = 131.5 \text{ mV}_{PP} / 2 = 65.7 \text{ mV}_{PP}$$

3. Determine the DC average of the two inputs ( $V_{L\_CM}$ ) by using the following expression:

$$V_{L\_CM} = 12.6 \text{ mA} \cdot R_E \cdot R_S / (R_S + R_G + R_E)$$

where

- $R_E = 25\Omega$
  - $R_G = 39\Omega$  (both internal to the LMH6555)
- (16)

For Figure 27:

$$R_S = 50\Omega \rightarrow V_{L\_CM} = 15.75 / (R_S + 64)$$

$$V_{L\_CM} = 15.75 / (50 + 64) = 138.2 \text{ mV} \quad (17)$$

4. Calculate  $V_{OUT}$  knowing the Insertion Gain ( $A_{V\_DIFF}$ ):

$$V_{OUT} = (V_{IN} \cdot / 2) \cdot A_{V\_DIFF}$$

$$A_{V\_DIFF} = 2 \cdot R_F / (2R_S + R_{IN\_DIFF})$$

where

- $R_F = 430\Omega$
  - $R_{IN\_DIFF} = 78\Omega$
- (18)

For Figure 27:

$$R_S = 50\Omega \rightarrow A_{V\_DIFF} = 4.83 \text{ V/V}$$

$$V_{OUT} = (0.3 \text{ V}_{PP} / 2) \cdot 4.83 \text{ V/V} = 724.5 \text{ mV}_{PP} \quad (19)$$

The values determined with the procedure outlined here are shown in Figure 28.

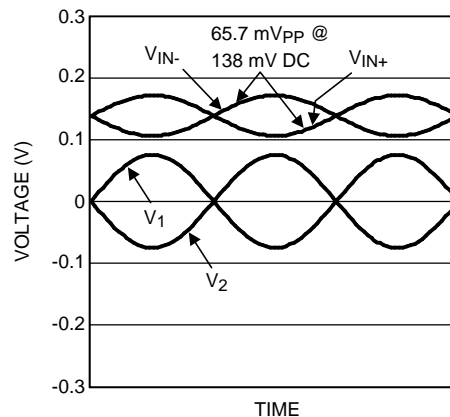

Figure 28. Input Voltage for Figure 27 Schematic

## SOURCE IMPEDANCE(S) AND THEIR EFFECT ON GAIN AND OFFSET

The source impedances  $R_{S1}$  and  $R_{S2}$ , as shown in [Figure 25](#) or [Figure 27](#), affect gain and output offset. The [Electrical Characteristics](#) and [TYPICAL PERFORMANCE CHARACTERISTICS](#) are generated with equal valued source impedances  $R_{S1}$  and  $R_{S2}$ , unless otherwise specified. Any mismatch between the values of these two impedances would alter the gain and offset voltage.

## OUTPUT OFFSET CONTROL AND ADJUSTMENT

There are applications which require that the LMH6555 differential output voltage be set by the user. An example of such an application is a unipolar signal which is converted to a differential output by the LMH6555. In order to utilize the full scale range of the ADC input, it is beneficial to shift the LMH6555 outputs to the limits of the ADC analog input range under minimal signal condition. That is, one LMH6555 output is shifted close to the negative limit of the ADC analog input and the other close to the positive limit of the ADC analog input. Then, under maximum signal condition, with proper gain, the full scale range of the ADC input can be traversed and the ADC input dynamic range is properly utilized. If this forced offset were not imposed, the ADC output codes would be reduced to half of what the ADC is capable of producing, resulting in a significant reduction in ENOB. The choice of the direction of this shift is determined by the polarity of the expected signal.

Another scenario where it may be necessary to shift the LMH6555 output offset voltage is in applications where it is necessary to improve the specified Output Offset Voltage (differential mode), " $V_{OOS}$ ". Some ADC's, including the ADC081000/ ADC081500 (and their dual counterparts), have internal registers to correct for the driver's (LMH6555)  $V_{OOS}$ . If the LMH6555  $V_{OOS}$  rating exceeds the maximum value allowed into this register, then shifting the output is required for maximum ADC performance.

It is possible to affect output offset voltage by manipulating the value of one input resistance relative to the other (e.g.  $R_{S1}$  relative to  $R_{S2}$  or vice versa). However, this will also alter the gain. Assuming that the source is applied to the  $V_{IN}^+$  side through  $R_{S1}$ , [Figure 29\(A\)](#) shows the effect of varying  $R_{S1}$  on the overall gain and output offset voltage. [Figure 29\(B\)](#) shows the same effects but this time for when the undriven side impedance,  $R_{S2}$ , is varied.

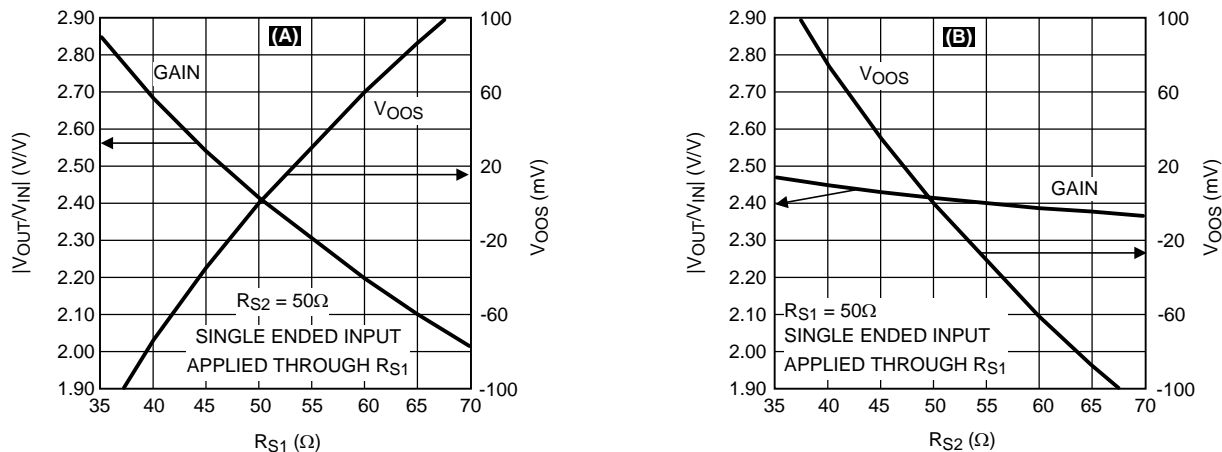

**Figure 29. Gain & Output Offset Voltage vs. Source Impedance Shift for Single Ended Input Drive**

As can be seen in [Figure 29](#), the source impedance of the input side being driven has a bigger effect on gain than the undriven source impedance.  $R_{S1}$  and  $R_{S2}$  affect the output offset in opposite directions. Manipulating the value of  $R_{S2}$  for offset control has another advantage over doing the same to  $R_{S1}$  and that is the signal input termination is not affected by it. This is especially important in applications where the signal is applied to the LMH6555 through a transmission line which needs to be terminated in its characteristic impedance for minimum reflection.

For reference, [Figure 30](#) shows the effect of source impedance mismatch on overall gain and output offset voltage with differential input drive.

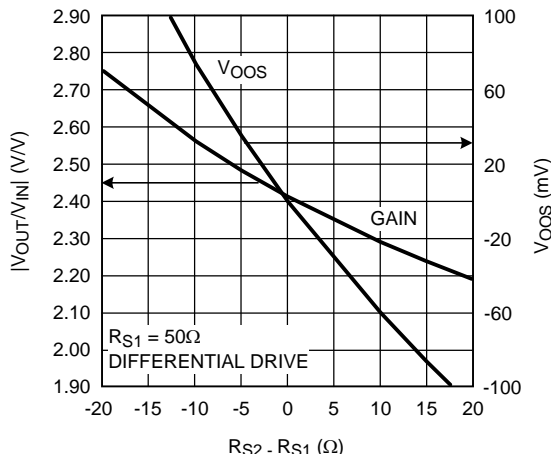

Figure 30. Gain & Output Offset Voltage vs. Source Impedance Shift for Differential Input Drive

It is possible to manipulate output offset with little or no effect on source resistance balance, gain, and, cable termination.

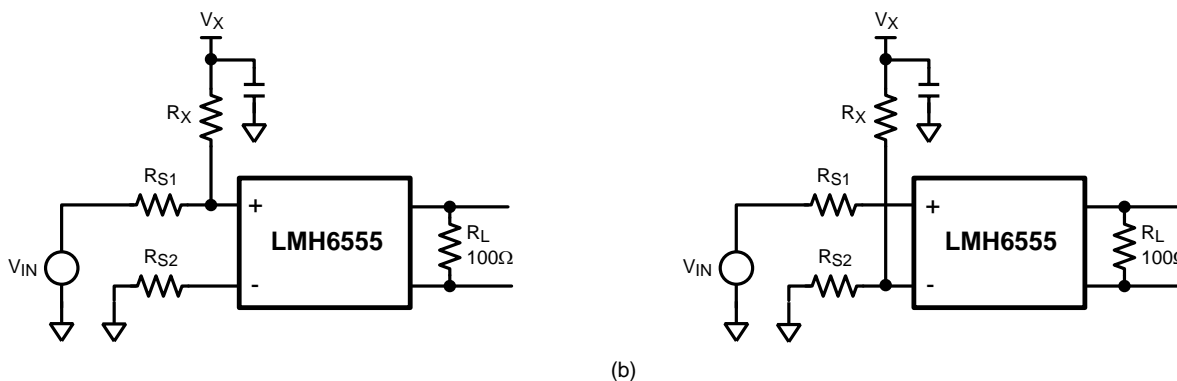

Figure 31. Differential Output Shift Circuits

$R_X$ , shown in [Figure 31\(a\)](#) and [Figure 31\(b\)](#), injects current into the input to achieve the required output shift. For a positive shift, positive current would need to be injected into the  $V_{IN}^+$  terminal ([Figure 31\(a\)](#)) and for a negative shift, to the  $V_{IN}^-$  terminal ([Figure 31\(b\)](#)). [Figure 32](#) shows the effect of  $R_X$  on the output with  $V_X = 3.3V$  or  $5V$ , and  $R_{S1} = R_{S2} = 50\Omega$ .

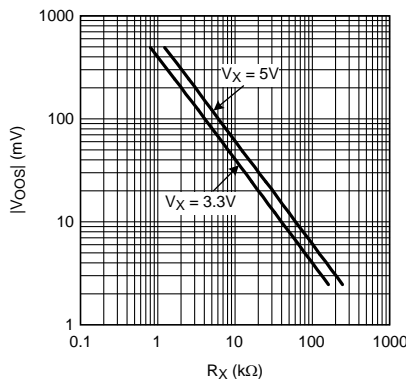
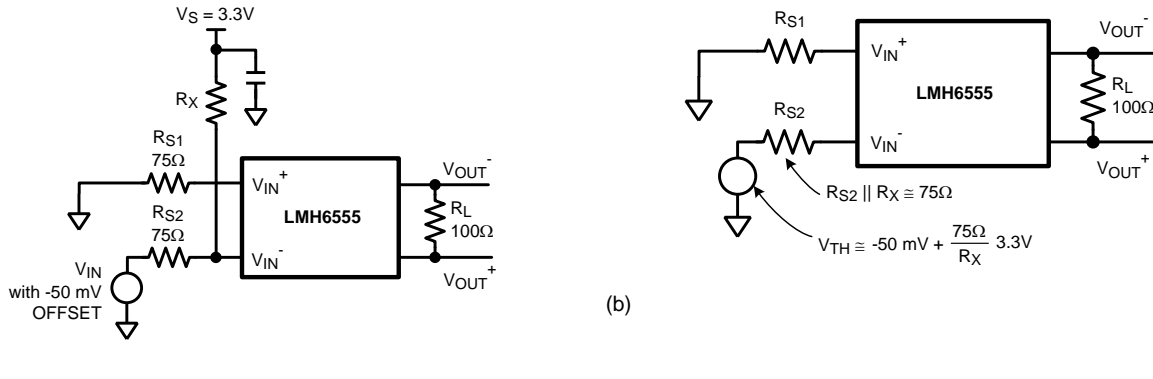

Figure 32. LMH6555 Differential Output Shift Due to  $R_X$  in [Figure 31](#)

To shift the LMH6555 differential output negative by about 100 mV, referring to the plot in [Figure 32](#),  $R_X$  would be chosen to be around 3.9 k $\Omega$  in the schematic of [Figure 31\(b\)](#) (using  $V_X = V_S = 3.3V$ ).

In applications where  $V_{IN}$  has a built-in non-zero offset voltage, or when  $R_{S1}$  and  $R_{S2}$  are not 50 $\Omega$ , the [Figure 32](#) plot cannot be used to estimate the required value for  $R_X$ .

Consider the case of a more general offset correction application, shown in [Figure 33\(a\)](#), where  $R_{S1} = R_{S2} = 75\Omega$  and  $V_{IN}$  has a built-in offset of  $-50$  mV. It is necessary to shift the differential output offset voltage of the LMH6555 to 0 mV. [Figure 33\(b\)](#) is the Thevenin equivalent of the circuit in [Figure 33\(a\)](#) assuming  $R_X \gg R_{S2}$ .



**Figure 33. Offset Correction Example ( $R_S = 75\Omega$ )**

From the gain expression in [Equation 44](#) (see [Appendix](#)) (but with opposite polarity because  $V_{TH}$  is applied to  $V_{IN-}$  instead):

$$\frac{V_{OUT}}{V_{TH}} = \frac{-R_F}{2R_S + 78} \Rightarrow$$

$$V_{OUT} = \frac{-430\Omega}{(150 + 78)\Omega} \times \left( -50 \text{ mV} + \frac{75}{R_X} \cdot 3.3V \right) \quad (20)$$

The expression derived for  $V_{OUT}$  in [Equation 20](#) can be set equal to zero to solve for  $R_X$  resulting in  $R_X = 4.95$  k $\Omega$ . If the differential output offset voltage,  $V_{OOS}$ , is also known,  $V_{OUT}$  could be set to a value equal to  $-V_{OOS}$ . For example, if the  $V_{OOS}$  for the particular LMH6555 is  $+30$  mV, then the following nulls the differential output:

$$V_{OUT} = -30 \text{ mV} = (-1.89) \left( -50 \text{ mV} + \frac{248}{R_X} \right) \Rightarrow R_X = 3.76 \text{ k}\Omega \quad (21)$$

$R_X \gg R_{S2}$  confirming the assumption made in the derivation. Note that [Equation 21](#), which is derived based on the configuration in [Figure 31\(b\)](#), will yield a real solution for  $R_X$  if and only if:

$$V_{OOS} \geq (V_{IN\_OFFSET} \times 1.89)$$

For [Figure 31\(b\)](#) and with  $R_S = 75\Omega$

where

- $V_{IN\_OFFSET}$  is the source offset shown as  $-50$  mV in [Figure 33\(a\)](#) (22)

If [Equation 22](#) were not satisfied, then [Figure 31\(a\)](#) offset correction, where  $R_X$  is tied to the  $V_{IN+}$  side, should be employed instead.

Alternatively, replace the  $V_X$  and  $R_X$  combination with a discrete current source or current sink. Because of a current source's high output impedance, there will be less gain imbalance. However, a current source might have a relatively large output capacitance which could degrade high frequency performance.

## INTERFACE DESIGN EXAMPLE

As shown in [Figure 34](#) below, the LMH6555 can be used to interface an open collector output device (U1) to a high speed ADC. In this application, the LMH6555 performs the task of amplifying and driving the 100 $\Omega$  differential input impedance of the ADC.

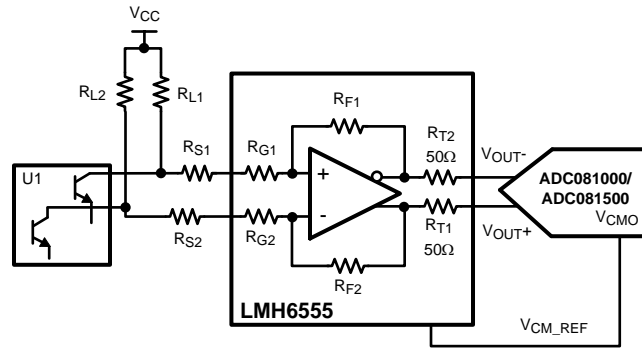

$V_{CM\_REF}$  buffer not shown

**Figure 34. Differential Amplification and ADC Drive**

For applications similar to the one shown in [Figure 34](#), the following conditions should be maintained:

1. The LMH6555 differential output voltage has to comply with the ADC full scale voltage (800 mV<sub>PP</sub> in this case).
2. The LMH6555 input Common Mode Voltage Range is observed. “CMVR”, as specified in [Electrical Characteristics](#), is to be between -0.3V and 2.0V for the specified CMRR.
3. U1 collector voltage swing must be observed so that the U1 output transistors do not saturate. The expected operating range of these output transistors is defined by the specifications and operating conditions of U1.

Consider a numerical example ( $R_L$  refers to  $R_{L1}$  &  $R_{L2}$ ,  $R_S$  refers to  $R_{S1}$  &  $R_{S2}$ ).

Assume:

$V_{CC} = 10V$ , U1 peak-to-peak collector current ( $I_{PP}$ ) = 15 mA<sub>PP</sub> with 10 mA quiescent ( $I_{cQ}$ ), and minimum operational U1 collector voltage = 6V.

Here are the series of steps to take in order to carry out this design:

- a. Select the  $R_L$  value which allows compliance with the U1 collector voltage (6V in this case) with 1V extra as margin because of LMH6555 loading.  

$$R_L = [10 - (6+1)] V / (10 + 7.5) mA = 171\Omega$$

Choose 169Ω, 1% resistors for  $R_L$
- b. Find the value of  $R_S$  to get the proper swing at the output (800 mV<sub>PP</sub>). To do so, convert the input stage into its Norton equivalent as shown in [Figure 35](#)

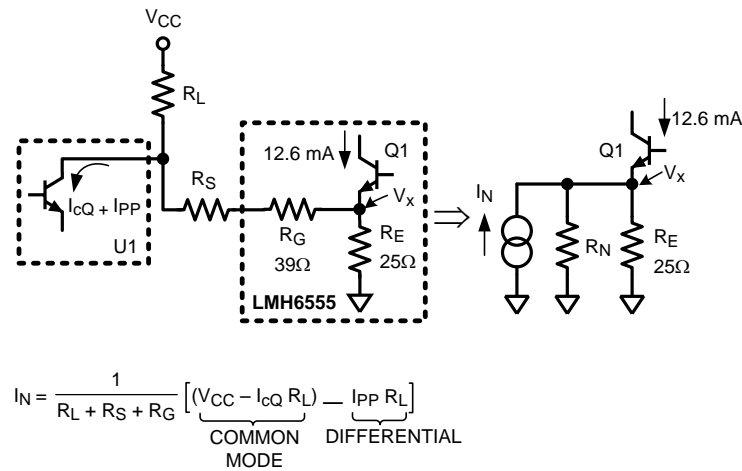

Figure 35. Norton Equivalent of the Input Circuitry Tied to Q1 within the LMH6555 in Figure 34

$$I_N = I_N (\text{common mode}) + I_N (\text{differential})$$

$$I_N (\text{common mode}) = (V_{CC} - I_{CQ} * R_L) / (R_L + R_S + R_G)$$

$$I_N (\text{differential}) = I_{PP} * R_L / (R_L + R_S + R_G) \tag{23}$$

The entirety of the Norton source differential component will flow through the feedback resistors within the LMH6555 and generate an output. Therefore:

$$I_N (\text{differential}) * R_F = 800 \text{ mV}_{PP}$$

$$\rightarrow R_S = (R_L * I_{PP} * R_F / 0.8) - R_G - R_L$$

where

- $R_F = 430\Omega$
- $R_G = 39\Omega$  ( $R_F$  and  $R_G$  are internal LMH6555 resistances)

$$\tag{24}$$

So, in this case:

$$R_S = (169 * 15 \text{ mA}_{PP} * 430 / 0.8) - 39 - 169 = 1154\Omega$$

Choose 1.15 kΩ, 1% resistors for  $R_S$  (25)

- c. With  $R_L$  and  $R_S$  defined, ensure that the U1 collector voltage(s) minimum is not violated due to the loading effect of the LMH6555 through  $R_S$ . Also, it is important to ensure that the LMH6555's CMVR is also not violated.

The “ $V_x$ ” node voltage within the LMH6555 (see Figure 35) would need to be calculated. Use the Common Mode component of the Norton equivalent source from above, and write the KCL at the  $V_x$  node as follows:

$$V_x / R_E + V_x / R_N = 12.6 \text{ mA} + I_N (\text{common mode}); \text{ with } R_E = 25\Omega$$

$$V_x / R_E + V_x / R_N = 12.6 \text{ mA} + (V_{CC} - I_{CQ} R_L) / (R_L + R_S + R_G)$$

$$\rightarrow V_x = 0.4595V \tag{26}$$

With  $V_x$  calculated, both the input voltage range (high and low) and the low end of the U1 collector voltage ( $V_C$ ) can be derived to be within the acceptable range. If necessary, steps “a” through “c” would have to be repeated to readjust these values.

$$V_C = V_x R_L / R_N + I_N (R_S + R_G) \tag{27}$$

$$I_{N\_High} = 7.05 \text{ mA}, I_{N\_Low} = 5.19 \text{ mA} \text{ (based on the values derived)}$$

$$\rightarrow V_{C\_High} = 0.4595 * 169 / 1358 + 7.05 \text{ mA} (1150 + 39) = 8.44V$$

$$\rightarrow V_{C\_Low} = 0.4595 * 169 / 1358 + 5.19 \text{ mA} (1150 + 39) = 6.22V \tag{28}$$

$$V_{IN} = V_X (R_N - R_G) / R_N + I_N R_G$$

$$\rightarrow V_{IN\_High} = 0.4595 * (1358 - 39) / 1358 + 7.05 \text{ mA} * 39 = 0.721\text{V}$$

$$\rightarrow V_{IN\_Low} = 0.4595 * (1358 - 39) / 1358 + 5.19 \text{ mA} * 39 = 0.649\text{V} \quad (29)$$

Figure 36 shows the complete solution using the values derived above, with the node voltages marked on the schematic for reference.

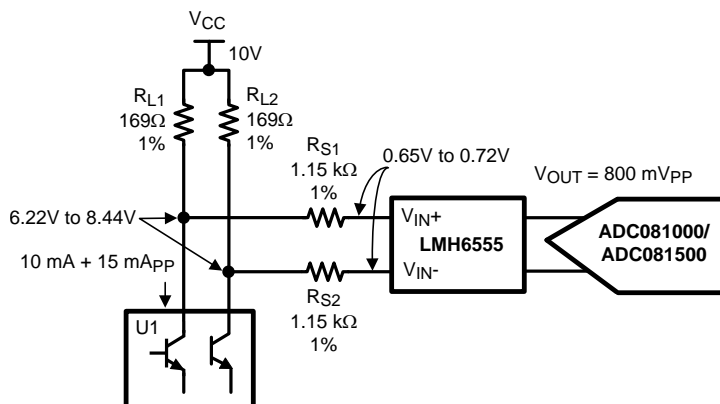

Figure 36. Implementation #1 of Figure 34 Design Example

It is important to note that the matching of the resistors on either input side of the LMH6555 ( $R_{S1}$  to  $R_{S2}$  and  $R_{L1}$  to  $R_{L2}$ ) is very important for output offset voltage and gain balance. This is particularly true with values of  $R_S$  higher than the nominal 50Ω. Therefore, in this example, 1% or better resistor values are specified.

If the U1 collector voltage turns out to be too low due to the loading of the LMH6555, lower  $R_L$ . Lower values of  $R_L$  result in lower  $R_S$  which in turn increases the LMH6555's  $V_{I\_CM}$  because of increased pull up action towards  $V_{CC}$ . The upper limit on  $V_{I\_CM}$  is 2V. Figure 37 shows the 2<sup>nd</sup> implementation of this same application with lowered values of  $R_L$  and  $R_S$ . Notice that the lower end of U1's collector voltage and the upper end of LMH6555's  $V_{I\_CM}$  have both increased compared to the 1<sup>st</sup> implementation.

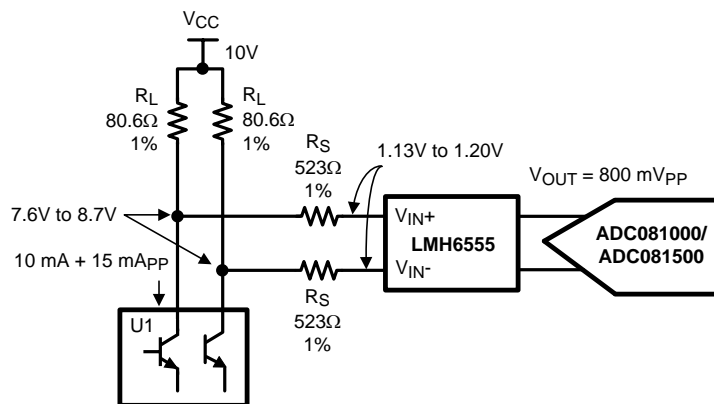

Figure 37. Implementation #2 of Figure 34 Design Example

An alternative would be to AC couple the LMH6555 inputs. With this approach, the design steps would be very similar to the ones outlined except that there would be no common mode interaction between the LMH6555 and U1 and this results in fewer design constraints:

$$V_X / R_E = 12.6 \text{ mA} \rightarrow V_X = 0.315\text{V} \quad (30)$$

For the component values shown in [Figure 37](#) use:

$$1. \quad V_{C\_High} = V_{CC} - R_L (I_{CQ} + I_{PP} / 2 - I_N \text{ (differential)} / 2)$$

$$V_{C\_Low} = V_{CC} - R_L (I_{CQ} - I_{PP} / 2 + I_N \text{ (differential)} / 2) \quad (31)$$

$$I_N \text{ (differential)} = I_{PP} * R_L / (R_L + R_S + R_G) = 1.88 \text{ mA (based on the values used.)}$$

$$\rightarrow V_{C\_High} = 10 - 80.6 (10 + 15 / 2 - 1.88 / 2) \text{ mA} = 8.67\text{V}$$

$$\rightarrow V_{C\_Low} = 10 - 80.6 (10 - 15 / 2 + 1.88 / 2) \text{ mA} = 9.72\text{V} \quad (32)$$

$$V_{IN} = V_X \pm R_G * I_N \text{ (differential)} / 2$$

$$\rightarrow V_{IN\_High} = 0.3150 + 39 * 1.88 \text{ mA} / 2 = 0.3517\text{V}$$

$$\rightarrow V_{IN\_Low} = 0.3150 - 39 * 1.88 \text{ mA} / 2 = 0.2783\text{V} \quad (33)$$

[Figure 38](#) shows the AC coupled implementation of the [Figure 37](#) schematic along with the node voltages marked to demonstrate the reduced  $V_{L\_CM}$  of the LMH6555 and the increase in the U1 collector voltage minimum.

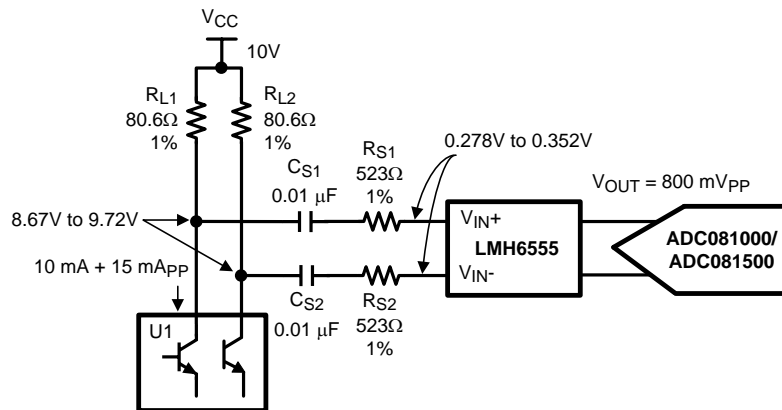

**Figure 38. AC Coupled Version of [Figure 37](#)**

Note that the lower cut-off frequency is:

$$f_{\text{cut-off}} = 1 / (\pi R_{eq} C_S) \text{ where } R_{eq} = R_{S1} + R_{S2} + R_{IN\_DIFF} \text{ where } R_{IN\_DIFF} \approx 78\Omega \quad (34)$$

So, for the component values shown ( $C_S = 0.01 \mu\text{F}$  and  $R_{S1} = R_{S2} = 523\Omega$ ):

$$f_{\text{cut-off}} = 28.2 \text{ kHz} \quad (35)$$

DATA ACQUISITION APPLICATIONS

Figure 39 shows the LMH6555 used as the differential driver to the Texas Instruments ADC081500 running at 1.5G samples/second.

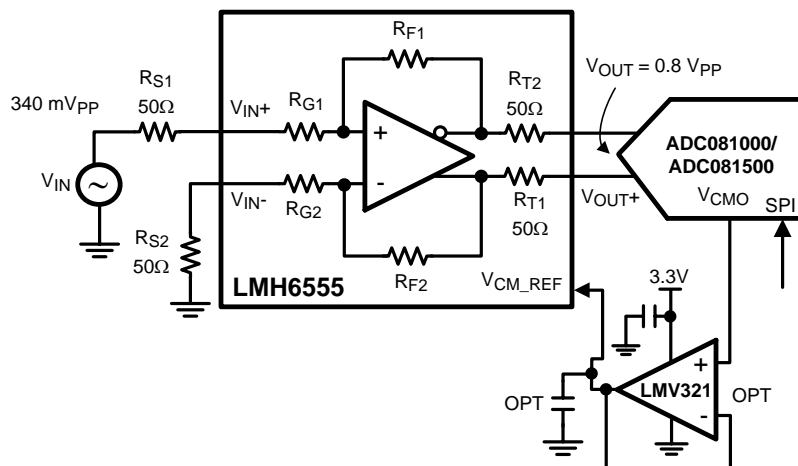

Figure 39. Schematic of the LMH6555 Interfaced to the ADC081500

In the schematic of Figure 39, the LMH6555 converts a single ended input into a differential output for direct interface to the ADC's 100Ω differential input. An alternative approach to using the LMH6555 for this purpose, would have been to use a balun transformer, as shown in Figure 40.

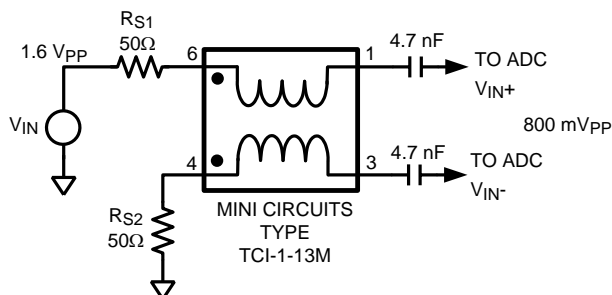

Figure 40. Single Ended to Differential Conversion (AC only) with a Balun Transformer

In the circuit of Figure 40, the ADC will see a 100Ω differential driver which will swing the required 800 mVpp when VIN is 1.6 Vpp. The source (VIN) will see an overall impedance of 200Ω for the frequency range that the transformer is specified to operate. Note that with this scheme, the signal to the ADC must be AC coupled, because of the transformer's minimum operating frequency which would prevent DC coupling. For the transformer specified, the lower operating frequency is around 4.5 MHz and the input high pass filter's -3 dB bandwidth is around 340 kHz for the values shown (or  $(1/\pi R_{EQ}C)$ Hz where  $R_{EQ} = 200\Omega$ ).

Table 1 compares the LMH6555 solution (Figure 39) vs. that of the balun transformer coupling (Figure 40) for various categories.

**Table 1. ADC Input Coupling Schemes Compared**

Category	Preferred Solution	
	LMH6555	Balun Transformer
Lower Power Consumption		✓
Lower Distortion		✓
Wider Dynamic Range	✓	
DC Coupling & Broadband Applications	✓	
Highest Gain & Phase Balance	✓	
Input/ Output Broadband Impedance Matching (Highest Return Loss)	✓	
Additional Gain	✓	
ADC Input Protection against Overdrive	✓	
Highest SNR	✓	
Ability to Control Gain Flatness	✓ (see below)	

**GAIN FLATNESS**

In applications where the full 1.2 GHz bandwidth of the LMH6555 is not necessary, it is possible to improve the gain flatness frequency at the expense of bandwidth. Figure 41 shows  $C_O$  placed across the LMH6555 output terminals to reduce the frequency response gain peaking and thereby to increase the  $\pm 0.5$  dB gain flatness frequency.

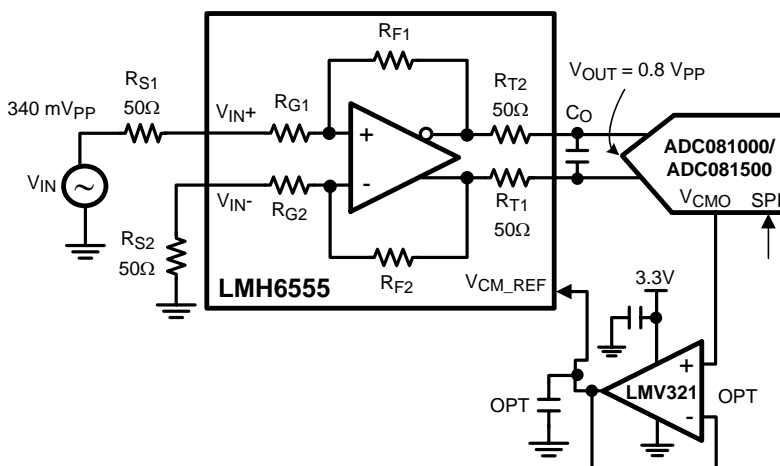

**Figure 41. Increasing  $\pm 0.5$  dB Gain Flatness using External Output Capacitance,  $C_O$**

Figure 42, Figure 43, and and Figure 44 show the FFT analysis results with the setup shown in Figure 39.

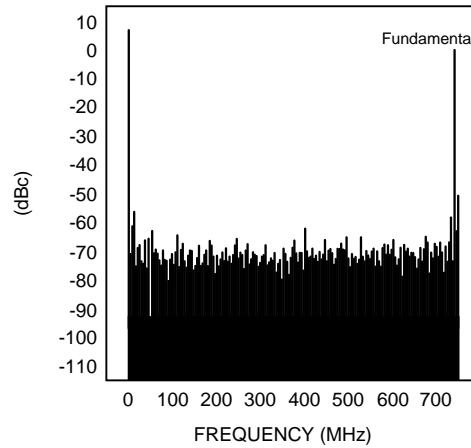

Figure 42. LMH6555 FFT Result When Used as the Differential Driver to ADC081500

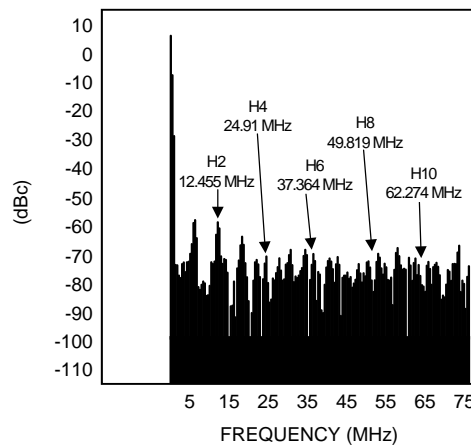

Figure 43. LMH6555 FFT Result When Used as the Differential Driver to ADC081500 (Lower  $F_s/2$  Region Magnified)

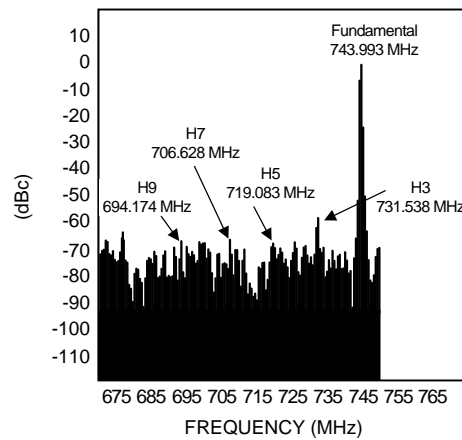

Figure 44. LMH6555 FFT Result When Used as the Differential Driver to ADC081500 (Upper  $F_s/2$  Region Magnified)

Figure 42, Figure 43, and Figure 44 information summary:

- Fundamental Test Frequency 744 MHz
- LMH6555 Output 0.8 V<sub>PP</sub>
- Sampling Rate: 1.5G samples/second
- 2nd Harmonic: -59 dBc @ ~ 12 MHz or |1.5 GHz\*1– 744 MHz\*2|
- 3rd Harmonic: -57 dBc @ ~ 732 MHz or |1.5 GHz\*1- 744 MHz \*3|
- 4th Harmonic -71 dBc @ ~ 24 MHz or |1.5 GHz\*2 – 744 MHz \*4|
- 5th Harmonic -68 dBc @ ~ 720 MHz or |1.5 GHz\*2- 744 MHz\*5|
- 6th Harmonic -68 dBc @ ~ 36 MHz or |1.5 GHz\*3- 744 MHz\*6|
- THD -51.8 dBc
- SNR 43.4 dB
- Spurious Free Dynamic
- Range (SFDR): 57 dB
- SINAD 42.8 dB
- ENOB 6.8 bits

The LMH6555 is capable of driving a variety of Texas Instruments Analog to Digital Converters. This is shown in Table 2, which offers a complete list of possible signal path ADC+ Amplifier combinations. The use of the LMH6555 to drive an ADC is determined by the application and the desired sampling process (Nyquist operation, sub-sampling or over-sampling). See application note AN-236 (SNAA079) for more details on the sampling processes and application note AN-1393 (SNOA461) for details on “Using High Speed Differential Amplifiers to Drive ADCs”. For more information regarding a particular ADC, refer to the particular ADC datasheet for details.

**Table 2. Differential Input ADC's Compatible with the LMH6555 Driver**

ADC Part Number	Resolution (bits)	Single/Dual	Speed (MSPS)
ADC08D500	8	S	500
ADC081000	8	S	1000
ADC08D1000	8	D	1000
ADC08D1020	8	D	1000
ADC081500	8	S	1500
ADC08D1500	8	D	1500
ADC08D1520	8	D	1500
ADC083000	8	S	3000
ADC08B3000	8	S	3000

## EXPOSED PAD WQFN PACKAGE

The LMH6555 is in a thermally enhanced package. The exposed pad (device bottom) is connected to the GND pins. It is recommended, but not necessary, that the exposed pad be connected to the supply ground plane. The thermal dissipation of the device is largely dependent on the connection of this pad. The exposed pad should be attached to as much copper on the circuit board as possible, preferably external copper. However, it is very important to maintain good high speed layout practices when designing a system board.

Here is a link to more information on the Texas Instruments 16-pin WQFN package:

<http://www.ti.com/packaging>

## EVALUATION BOARD

Texas Instruments suggests the following evaluation board as a guide for high frequency layout and as an aid in device testing and characterization.

Device	Package	Evaluation Board Ordering ID
LMH6555	16-Pin WQFN	LMH6555EVAL

The evaluation board can be ordered when a device sample request is placed with Texas Instruments.

## Appendix

Here is a more detailed analysis of the LMH6555, including the derivation of the expressions used throughout [APPLICATION INFORMATION](#).

### INPUT STAGE

Because of the input stage cross-coupling, if the instantaneous values of the input node voltages ( $V_{IN}^+$  and  $V_{IN}^-$ ) and current values are required, use the circuit of [Figure 45](#) as the equivalent input stage for each input ( $V_{IN}^+$  and  $V_{IN}^-$ ).

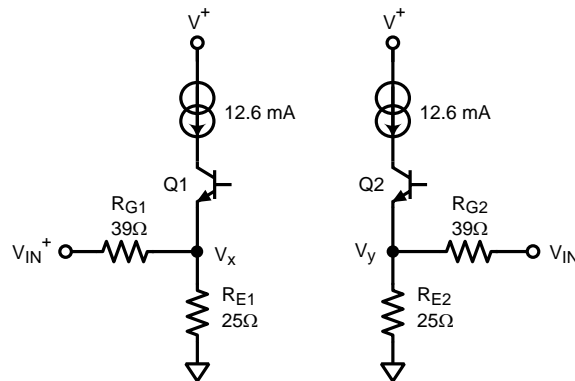

Figure 45. Equivalent Input Stage

Using this simplified circuit, one can assume a constant collector current, to simplify the analysis. This is a valid approximation as the large open loop gain of the device will keep the two collector currents relatively constant. First derive Q1 and Q2 emitter voltages. From there, derive the voltages at  $V_{IN}^+$  and  $V_{IN}^-$ .

With the component values shown, it is possible to analyze the input circuits of [Figure 45](#) in order to determine Q1 and Q2 emitter voltages. This will result in a first order estimate of Q1 and Q2 emitter voltages. Since Q1 and Q2 emitters are cross-coupled, the voltages derived would have to be equal. With the action of the common mode amplifier, “ $A_{CM}$ ”, shown in [Figure 24](#), these two emitters will be equalized. So, one other iteration can be performed whereby both emitters are set to be equal to the average of the 1<sup>st</sup> derived emitter voltages. Using this new emitter voltage, one could recalculate  $V_{IN}^+$  and  $V_{IN}^-$  voltages. The values derived in this fashion will be within  $\pm 10\%$  of the measured values.

### Single Ended Input Analysis

Here is an actual example to further clarify the procedure.

Consider the case where the LMH6555 is used as a single ended to differential converter shown in [Figure 46](#).

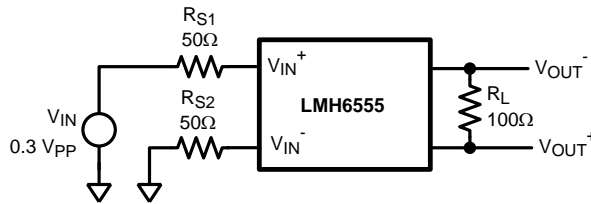

Figure 46. Single Ended Input Drive

The first task would be to derive the internal transistor emitter voltages based on the schematic of Figure 45 (assuming that there is no interaction between the stages.) Here is the derivation of  $V_x$  and  $V_y$ :

$$\frac{V_x}{25} + \frac{V_x \mp 0.15}{89} = 12.6 \text{ mA} \Rightarrow V_x = \begin{cases} 0.279\text{V} \\ 0.213\text{V} \end{cases}$$

$$\frac{V_y}{25} + \frac{V_y}{89} = 12.6 \text{ mA} \Rightarrow V_y = 0.246\text{V}$$

(36)

$V_x$  varies with  $V_{IN}^+$  (0.213V with negative  $V_{IN}$  swing and 0.279V with positive.) The values derived above assume that the two halves of the input circuit do not interact with each other. They do through the common mode amplifier and the input stage cross-coupling.  $V_x$  and  $V_y$  are equal to the average of  $V_y$  with either end of the swing of  $V_x$ . This is calculated below along with the derivation of  $V_{IN}^+$  and  $V_{IN}^-$  based on this new average emitter voltage (the average of  $V_x$  and  $V_y$ .)

$$\frac{V_x + V_y}{2} = \begin{cases} \frac{0.279 + 0.246}{2} = 0.262\text{V} \\ \frac{0.213 + 0.246}{2} = 0.229\text{V} \end{cases} = \text{Emitter Voltage Swing}$$

$$V_{IN}^+ = \pm 0.15\text{V} - 50 \frac{\pm 0.262\text{V} - 0.229\text{V}}{89}$$

$$V_{IN}^+ = \begin{cases} 0.213\text{V} \\ 63.2 \text{ mV} \end{cases}; V_{IN}^- = \frac{50}{89} \times \begin{cases} 0.262\text{V} \\ 0.229\text{V} \end{cases}$$

$$V_{IN}^- = \begin{cases} 0.147\text{V} \\ 0.129\text{V} \end{cases}$$

(37)

With 0.3  $V_{PP}$   $V_{IN}$ ,  $V_{IN}^+$  experiences 150 mV<sub>PP</sub> (213 mV - 63.2 mV) of swing and  $V_{IN}^-$  will swing by about 18.6 mV<sub>PP</sub> in the process (147 mV – 129 mV). The input voltages are shown in Figure 47.

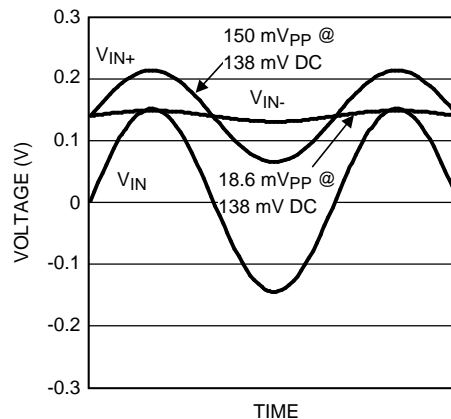

Figure 47. Input Voltages for Figure 46 Schematic

Using the calculated swing on  $V_{IN}^+$  with known  $V_{IN}$ , one can estimate the input impedance,  $R_{IN}$  as follows:

$$R_{IN} = \frac{\Delta V_{IN}^+}{\Delta I_{IN}^+} = \frac{150 \text{ mV}}{(-1.26 + 4.26) \text{ mA}} = 50\Omega \quad (38)$$

### Differential Input Analysis

Assume that the LMH6555 is used as a differential amplifier with a transformer with its Center Tap at ground as shown in [Figure 48](#):

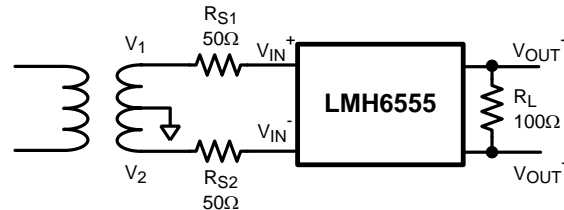

Assuming transformer secondary,  $V_{IN}$ , of  $300 \text{ mV}_{PP}$

**Figure 48. Differential Input Drive**

The input voltages ( $V_{IN}^+$  and  $V_{IN}^-$ ) can be derived using the technique explained previously. Assuming no transformer output and referring to the schematic of [Figure 45](#):

$$\frac{V_x}{25} + \frac{V_x}{50 + 39} = 12.6 \text{ mA} \Rightarrow V_x = V_y = 0.246 \text{ V}$$

$$V_{IN}^+ = \frac{50}{50 + 39} \times 0.246 \Rightarrow V_{IN}^+ = V_{IN}^- = 0.138 \text{ V} \quad (39)$$

The peak  $V_{IN}^+$  and  $V_{IN}^-$  voltages can be determined using the transformer output voltage. Assuming there is  $0.3 V_{PP}$  of signal across the transformer secondary,  $\frac{1}{2}$  of that, or  $0.15 V_{PP}$  ( $\pm 75 \text{ mV}$  peak), would appear at each input side ( $V_1$  or  $V_2$  in [Figure 48](#)). Here is the derivation of the LMH6555 input terminal's peak voltages.

$$\frac{V_x}{25} + \frac{V_x \pm 0.075}{89} = 12.6 \text{ mA} \Rightarrow V_x = \begin{cases} 262.4 \text{ mV} \\ 229.5 \text{ mV} \end{cases} \quad (40)$$

When  $V_1$  swings positive,  $V_2$  will go negative by the same value, and vice versa. Therefore, the values derived above for  $V_x$  can be used to determine the average emitter voltage, as described earlier:

$$\frac{V_x + V_y}{2} = \frac{262.4 \text{ mV} + 229.5 \text{ mV}}{2} = 245.9 \text{ mV} = \text{Emitter Voltage}$$

$$V_{IN}^+ = \pm 75 \text{ mV} - 50 \frac{\pm 75 \text{ mV} - 245.9 \text{ mV}}{89}$$

$$V_{IN}^+ = \begin{cases} 171.0 \text{ mV} \\ 105.3 \text{ mV} \end{cases} \text{ and by symmetry: } V_{IN}^- = \begin{cases} 105.3 \text{ mV} \\ 171.0 \text{ mV} \end{cases} \quad (41)$$

With the transformer voltage of  $0.3 V_{PP}$ , each input ( $V_{IN}^+$  and  $V_{IN}^-$ ) swings from  $105.3 \text{ mV}$  to  $171.0 \text{ mV}$  or about  $65.7 \text{ mV}_{PP}$ . The input voltages are shown in [Figure 49](#).

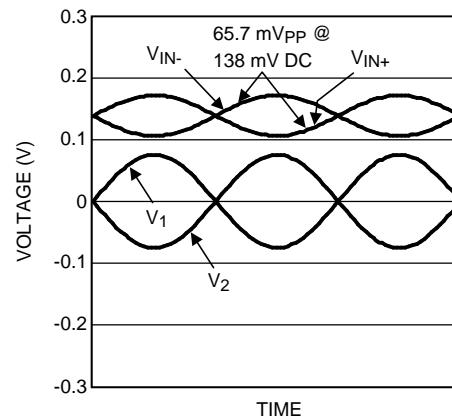

**Figure 49. Input Voltages for Figure 48 Schematic**

Knowing the device input terminal voltages, one can estimate the differential input impedance as follows:

$$\frac{R_{IN\_DIFF}}{R_{IN\_DIFF} + 100} = \frac{0.131 V_{PP}}{0.3 V_{PP}} \Rightarrow R_{IN\_DIFF} = 78\Omega \quad (42)$$

This is comparable to  $R_{IN\_DIFF}$  found in [Electrical Characteristics](#).

### OUTPUT STAGE AND GAIN ANALYSIS

Differential gain is determined by the differential current flow through the feedback resistors  $R_{F1}$  and  $R_{F2}$  as shown in [Figure 24](#). Current through  $R_{F1}$  (or  $R_{F2}$ ) sets the  $V_{OUT^-}$  (or  $V_{OUT^+}$ ) swing. The nominal value of these resistors is close to 430 $\Omega$ .

The LMH6555 output stage consists of two bipolar common emitter amplifiers with built in output resistances,  $R_{T1}$  and  $R_{T2}$ , of 50 $\Omega$ , as shown in [Figure 50](#).

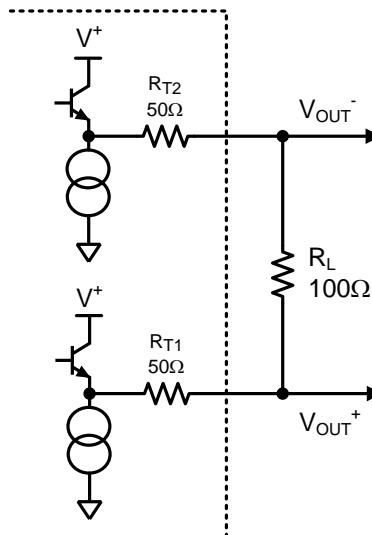
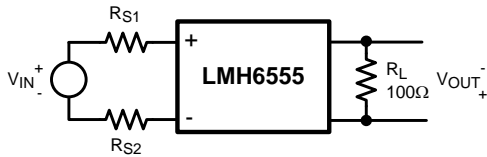

**Figure 50. Output Stage Including External Load  $R_L$**

With an output differential load,  $R_L$ , of 100 $\Omega$ , half the differential swing between the output emitters appears at the LMH6555 output terminals as  $V_{OUT^-}$ .

With good matching between the input source impedances,  $R_{S1}$  and  $R_{S2}$  shown in [Figure 46](#) and [Figure 48](#), it is possible to infer the gain and output swing by inspection. The differential input impedance of the LMH6555,  $R_{IN\_DIFF}$ , is close to  $78\Omega$ .

In differential input drive applications, there is a balanced swing across the input terminals of the LMH6555,  $V_{IN}^+$  and  $V_{IN}^-$ . So, by using the  $R_{IN\_DIFF}$  value, one determines the differential current flow through the input terminals and from that the output swing and gain.



$$V_{OUT} = \frac{V_{IN} \times R_F}{2R_S + R_{IN\_DIFF}}$$

$$\frac{V_{OUT}}{V_{IN}} = \frac{R_F}{2R_S + 78\Omega} = \frac{430\Omega}{2R_S + 78\Omega} \quad (43)$$

For the special case where  $R_{S1} = R_{S2} = R_S = 50\Omega$  we have:

$$\text{for } R_S = 50\Omega \Rightarrow \frac{V_{OUT}}{V_{IN}} = \frac{430}{178} = 2.42 \text{ V/V} \quad (44)$$

The following is the expression for the Insertion Gain,  $A_{V\_DIFF}$ :

$$\begin{aligned} A_{V\_DIFF} &= \frac{V_{OUT}}{V_{IN} \times \frac{100\Omega}{2R_S + 100}} \\ &= \frac{V_{OUT}/V_{IN}}{100/200} = 2 V_{OUT}/V_{IN} = 4.83 \text{ V/V} \\ &= 13.7 \text{ dB} \end{aligned} \quad (45)$$

The expressions above apply equally to the single ended input drive case as well, as long as  $R_{S1} = R_{S2} = 50\Omega$ . For the case of the single ended input drive:

$$\begin{aligned} A_{V\_DIFF} &= \frac{V_{OUT}}{V_{IN} \times \frac{50}{R_S + 50}} \\ &= \frac{V_{OUT}/V_{IN}}{50/100} = 2 V_{OUT}/V_{IN} = 4.83 \text{ V/V} \\ &= 13.7 \text{ dB} \end{aligned} \quad (46)$$

This is comparable to  $A_{V\_DIFF}$  found in [Electrical Characteristics](#).

## REVISION HISTORY

Changes from Revision C (March 2013) to Revision D	Page
• Changed layout of National Data Sheet to TI format .....	<a href="#">31</a>

**PACKAGING INFORMATION**

Orderable Device	Status (1)	Package Type	Package Drawing	Pins	Package Qty	Eco Plan (2)	Lead/Ball Finish (6)	MSL Peak Temp (3)	Op Temp (°C)	Device Marking (4/5)	Samples
LMH6555SQ/NOPB	ACTIVE	WQFN	RGH	16	1000	Green (RoHS & no Sb/Br)	CU SN	Level-3-260C-168 HR	-40 to 85	L6555SQ	<a href="#">Samples</a>
LMH6555SQE/NOPB	ACTIVE	WQFN	RGH	16	250	Green (RoHS & no Sb/Br)	CU SN	Level-3-260C-168 HR	-40 to 85	L6555SQ	<a href="#">Samples</a>

(1) The marketing status values are defined as follows:

**ACTIVE:** Product device recommended for new designs.

**LIFEBUY:** TI has announced that the device will be discontinued, and a lifetime-buy period is in effect.

**NRND:** Not recommended for new designs. Device is in production to support existing customers, but TI does not recommend using this part in a new design.

**PREVIEW:** Device has been announced but is not in production. Samples may or may not be available.

**OBSOLETE:** TI has discontinued the production of the device.

(2) Eco Plan - The planned eco-friendly classification: Pb-Free (RoHS), Pb-Free (RoHS Exempt), or Green (RoHS & no Sb/Br) - please check <http://www.ti.com/productcontent> for the latest availability information and additional product content details.

**TBD:** The Pb-Free/Green conversion plan has not been defined.

**Pb-Free (RoHS):** TI's terms "Lead-Free" or "Pb-Free" mean semiconductor products that are compatible with the current RoHS requirements for all 6 substances, including the requirement that lead not exceed 0.1% by weight in homogeneous materials. Where designed to be soldered at high temperatures, TI Pb-Free products are suitable for use in specified lead-free processes.

**Pb-Free (RoHS Exempt):** This component has a RoHS exemption for either 1) lead-based flip-chip solder bumps used between the die and package, or 2) lead-based die adhesive used between the die and leadframe. The component is otherwise considered Pb-Free (RoHS compatible) as defined above.

**Green (RoHS & no Sb/Br):** TI defines "Green" to mean Pb-Free (RoHS compatible), and free of Bromine (Br) and Antimony (Sb) based flame retardants (Br or Sb do not exceed 0.1% by weight in homogeneous material)

(3) MSL, Peak Temp. - The Moisture Sensitivity Level rating according to the JEDEC industry standard classifications, and peak solder temperature.

(4) There may be additional marking, which relates to the logo, the lot trace code information, or the environmental category on the device.

(5) Multiple Device Markings will be inside parentheses. Only one Device Marking contained in parentheses and separated by a "~" will appear on a device. If a line is indented then it is a continuation of the previous line and the two combined represent the entire Device Marking for that device.

(6) Lead/Ball Finish - Orderable Devices may have multiple material finish options. Finish options are separated by a vertical ruled line. Lead/Ball Finish values may wrap to two lines if the finish value exceeds the maximum column width.

**Important Information and Disclaimer:** The information provided on this page represents TI's knowledge and belief as of the date that it is provided. TI bases its knowledge and belief on information provided by third parties, and makes no representation or warranty as to the accuracy of such information. Efforts are underway to better integrate information from third parties. TI has taken and continues to take reasonable steps to provide representative and accurate information but may not have conducted destructive testing or chemical analysis on incoming materials and chemicals. TI and TI suppliers consider certain information to be proprietary, and thus CAS numbers and other limited information may not be available for release.

In no event shall TI's liability arising out of such information exceed the total purchase price of the TI part(s) at issue in this document sold by TI to Customer on an annual basis.

## TAPE AND REEL INFORMATION



### QUADRANT ASSIGNMENTS FOR PIN 1 ORIENTATION IN TAPE



\*All dimensions are nominal

Device	Package Type	Package Drawing	Pins	SPQ	Reel Diameter (mm)	Reel Width W1 (mm)	A0 (mm)	B0 (mm)	K0 (mm)	P1 (mm)	W (mm)	Pin1 Quadrant
LMH6555SQ/NOPB	WQFN	RGH	16	1000	178.0	12.4	4.3	4.3	1.3	8.0	12.0	Q1
LMH6555SQE/NOPB	WQFN	RGH	16	250	178.0	12.4	4.3	4.3	1.3	8.0	12.0	Q1

**TAPE AND REEL BOX DIMENSIONS**

\*All dimensions are nominal

Device	Package Type	Package Drawing	Pins	SPQ	Length (mm)	Width (mm)	Height (mm)
LMH6555SQ/NOPB	WQFN	RGH	16	1000	210.0	185.0	35.0
LMH6555SQE/NOPB	WQFN	RGH	16	250	210.0	185.0	35.0

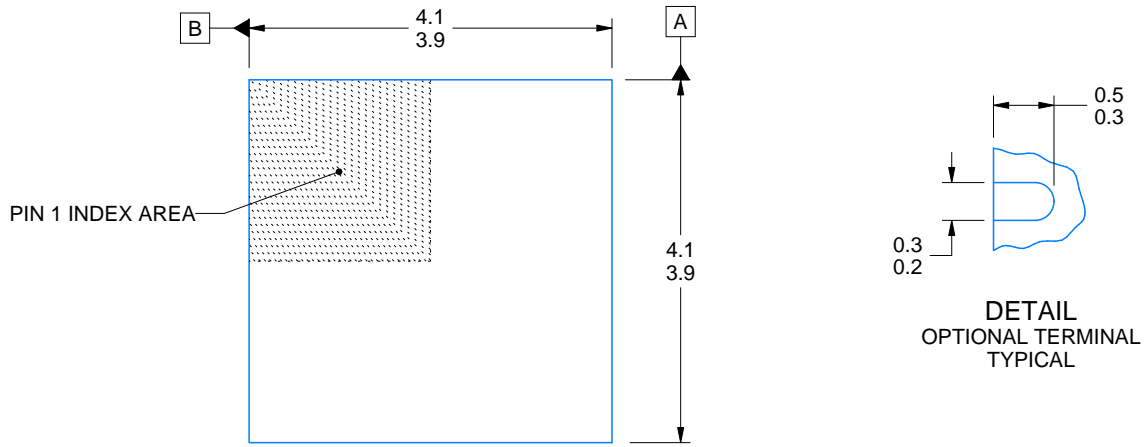
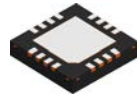

DIM A	
OPT 1	OPT 1
(0.1)	(0.2)

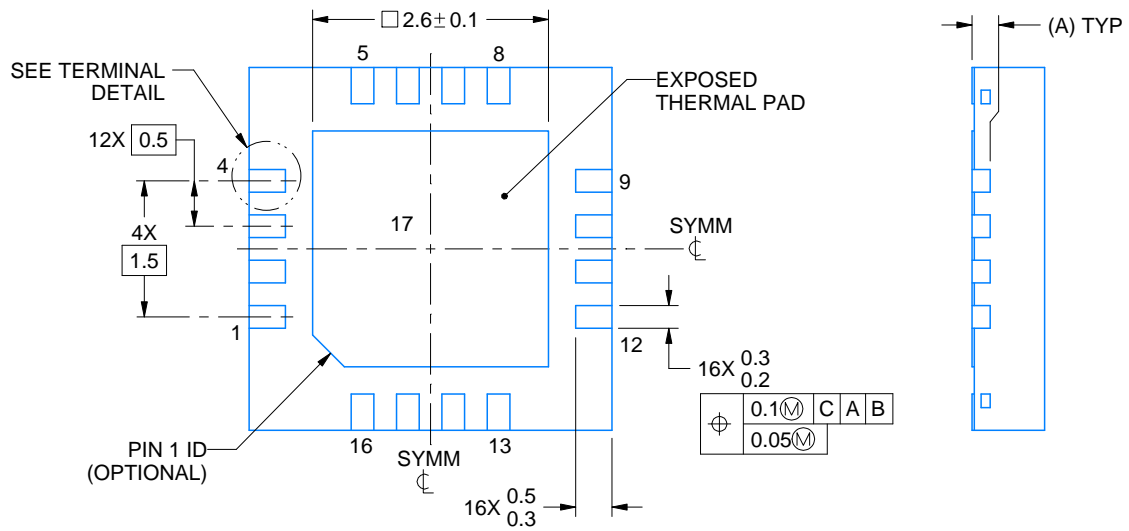
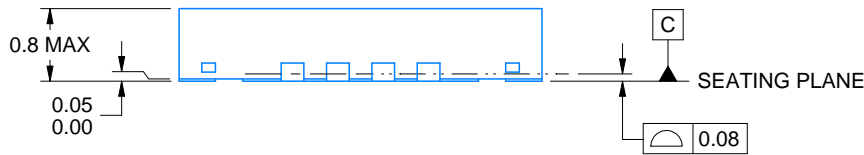

4214978/B 01/2017

NOTES:

1. All linear dimensions are in millimeters. Any dimensions in parenthesis are for reference only. Dimensioning and tolerancing per ASME Y14.5M.
2. This drawing is subject to change without notice.
3. The package thermal pad must be soldered to the printed circuit board for optimal thermal and mechanical performance.

# EXAMPLE BOARD LAYOUT

RGH0016A

WQFN - 0.8 mm max height

PLASTIC QUAD FLATPACK - NO LEAD

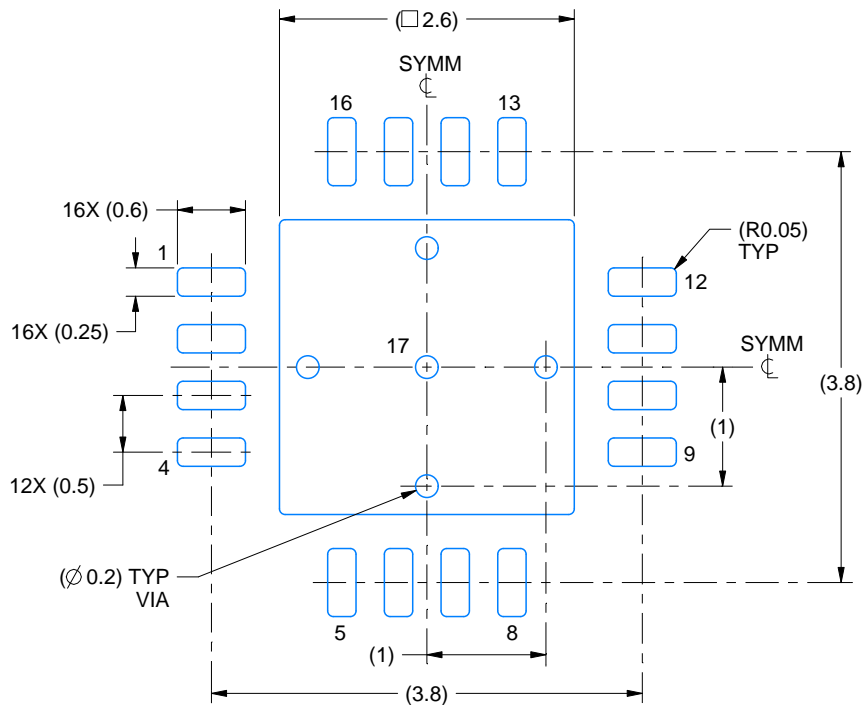

LAND PATTERN EXAMPLE  
EXPOSED METAL SHOWN  
SCALE:15X

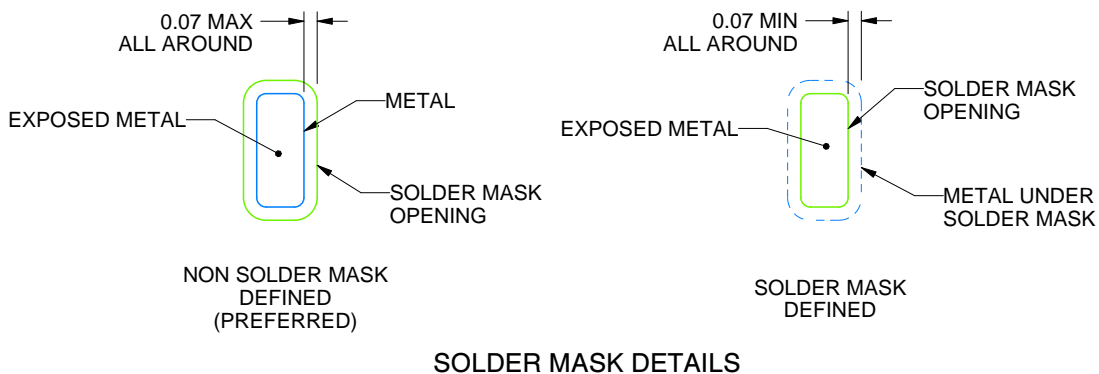

SOLDER MASK DETAILS

4214978/B 01/2017

NOTES: (continued)

- This package is designed to be soldered to a thermal pad on the board. For more information, see Texas Instruments literature number SLUA271 ([www.ti.com/lit/slua271](http://www.ti.com/lit/slua271)).
- Vias are optional depending on application, refer to device data sheet. If any vias are implemented, refer to their locations shown on this view. It is recommended that vias under paste be filled, plugged or tented.

# EXAMPLE STENCIL DESIGN

RGH0016A

WQFN - 0.8 mm max height

PLASTIC QUAD FLATPACK - NO LEAD

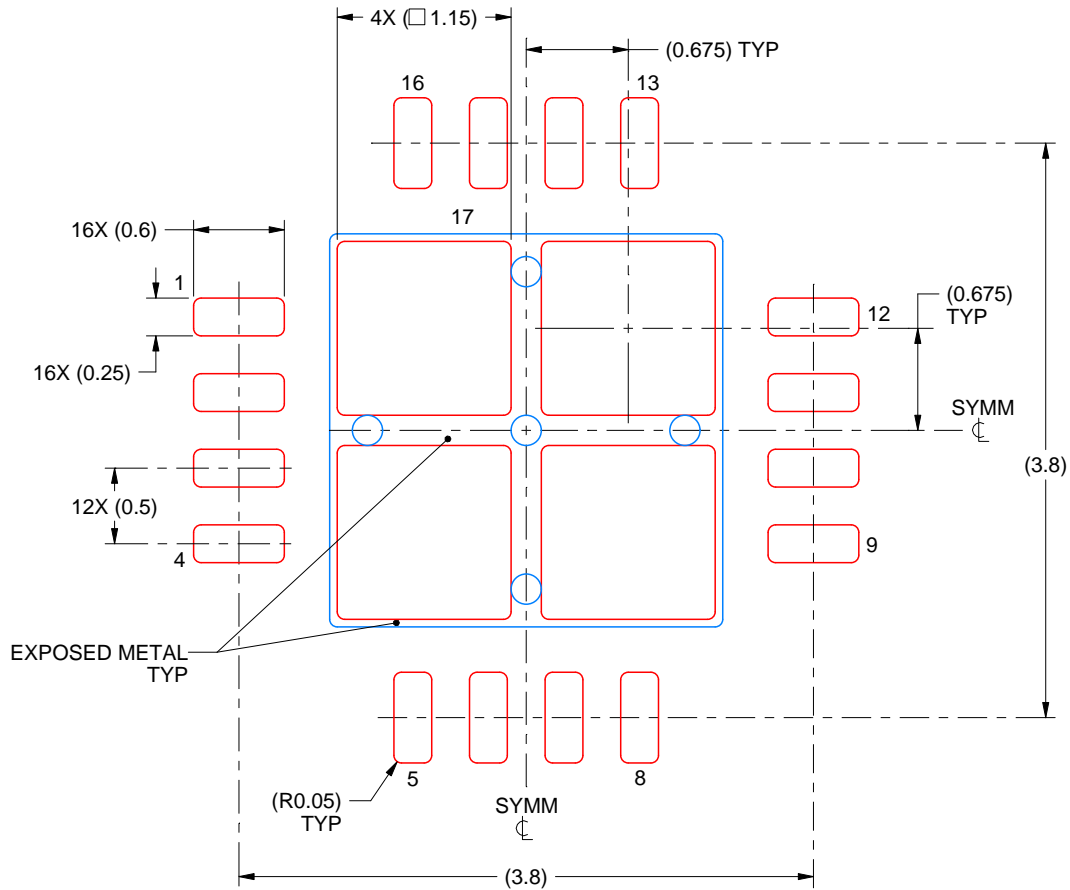

**SOLDER PASTE EXAMPLE**  
BASED ON 0.125 mm THICK STENCIL

EXPOSED PAD 17  
78% PRINTED SOLDER COVERAGE BY AREA UNDER PACKAGE  
SCALE:20X

4214978/B 01/2017

NOTES: (continued)

6. Laser cutting apertures with trapezoidal walls and rounded corners may offer better paste release. IPC-7525 may have alternate design recommendations.

## IMPORTANT NOTICE

Texas Instruments Incorporated (TI) reserves the right to make corrections, enhancements, improvements and other changes to its semiconductor products and services per JESD46, latest issue, and to discontinue any product or service per JESD48, latest issue. Buyers should obtain the latest relevant information before placing orders and should verify that such information is current and complete.

TI's published terms of sale for semiconductor products (<http://www.ti.com/sc/docs/stdterms.htm>) apply to the sale of packaged integrated circuit products that TI has qualified and released to market. Additional terms may apply to the use or sale of other types of TI products and services.

Reproduction of significant portions of TI information in TI data sheets is permissible only if reproduction is without alteration and is accompanied by all associated warranties, conditions, limitations, and notices. TI is not responsible or liable for such reproduced documentation. Information of third parties may be subject to additional restrictions. Resale of TI products or services with statements different from or beyond the parameters stated by TI for that product or service voids all express and any implied warranties for the associated TI product or service and is an unfair and deceptive business practice. TI is not responsible or liable for any such statements.

Buyers and others who are developing systems that incorporate TI products (collectively, "Designers") understand and agree that Designers remain responsible for using their independent analysis, evaluation and judgment in designing their applications and that Designers have full and exclusive responsibility to assure the safety of Designers' applications and compliance of their applications (and of all TI products used in or for Designers' applications) with all applicable regulations, laws and other applicable requirements. Designer represents that, with respect to their applications, Designer has all the necessary expertise to create and implement safeguards that (1) anticipate dangerous consequences of failures, (2) monitor failures and their consequences, and (3) lessen the likelihood of failures that might cause harm and take appropriate actions. Designer agrees that prior to using or distributing any applications that include TI products, Designer will thoroughly test such applications and the functionality of such TI products as used in such applications.

TI's provision of technical, application or other design advice, quality characterization, reliability data or other services or information, including, but not limited to, reference designs and materials relating to evaluation modules, (collectively, "TI Resources") are intended to assist designers who are developing applications that incorporate TI products; by downloading, accessing or using TI Resources in any way, Designer (individually or, if Designer is acting on behalf of a company, Designer's company) agrees to use any particular TI Resource solely for this purpose and subject to the terms of this Notice.

TI's provision of TI Resources does not expand or otherwise alter TI's applicable published warranties or warranty disclaimers for TI products, and no additional obligations or liabilities arise from TI providing such TI Resources. TI reserves the right to make corrections, enhancements, improvements and other changes to its TI Resources. TI has not conducted any testing other than that specifically described in the published documentation for a particular TI Resource.

Designer is authorized to use, copy and modify any individual TI Resource only in connection with the development of applications that include the TI product(s) identified in such TI Resource. NO OTHER LICENSE, EXPRESS OR IMPLIED, BY ESTOPPEL OR OTHERWISE TO ANY OTHER TI INTELLECTUAL PROPERTY RIGHT, AND NO LICENSE TO ANY TECHNOLOGY OR INTELLECTUAL PROPERTY RIGHT OF TI OR ANY THIRD PARTY IS GRANTED HEREIN, including but not limited to any patent right, copyright, mask work right, or other intellectual property right relating to any combination, machine, or process in which TI products or services are used. Information regarding or referencing third-party products or services does not constitute a license to use such products or services, or a warranty or endorsement thereof. Use of TI Resources may require a license from a third party under the patents or other intellectual property of the third party, or a license from TI under the patents or other intellectual property of TI.

TI RESOURCES ARE PROVIDED "AS IS" AND WITH ALL FAULTS. TI DISCLAIMS ALL OTHER WARRANTIES OR REPRESENTATIONS, EXPRESS OR IMPLIED, REGARDING RESOURCES OR USE THEREOF, INCLUDING BUT NOT LIMITED TO ACCURACY OR COMPLETENESS, TITLE, ANY EPIDEMIC FAILURE WARRANTY AND ANY IMPLIED WARRANTIES OF MERCHANTABILITY, FITNESS FOR A PARTICULAR PURPOSE, AND NON-INFRINGEMENT OF ANY THIRD PARTY INTELLECTUAL PROPERTY RIGHTS. TI SHALL NOT BE LIABLE FOR AND SHALL NOT DEFEND OR INDEMNIFY DESIGNER AGAINST ANY CLAIM, INCLUDING BUT NOT LIMITED TO ANY INFRINGEMENT CLAIM THAT RELATES TO OR IS BASED ON ANY COMBINATION OF PRODUCTS EVEN IF DESCRIBED IN TI RESOURCES OR OTHERWISE. IN NO EVENT SHALL TI BE LIABLE FOR ANY ACTUAL, DIRECT, SPECIAL, COLLATERAL, INDIRECT, PUNITIVE, INCIDENTAL, CONSEQUENTIAL OR EXEMPLARY DAMAGES IN CONNECTION WITH OR ARISING OUT OF TI RESOURCES OR USE THEREOF, AND REGARDLESS OF WHETHER TI HAS BEEN ADVISED OF THE POSSIBILITY OF SUCH DAMAGES.

Unless TI has explicitly designated an individual product as meeting the requirements of a particular industry standard (e.g., ISO/TS 16949 and ISO 26262), TI is not responsible for any failure to meet such industry standard requirements.

Where TI specifically promotes products as facilitating functional safety or as compliant with industry functional safety standards, such products are intended to help enable customers to design and create their own applications that meet applicable functional safety standards and requirements. Using products in an application does not by itself establish any safety features in the application. Designers must ensure compliance with safety-related requirements and standards applicable to their applications. Designer may not use any TI products in life-critical medical equipment unless authorized officers of the parties have executed a special contract specifically governing such use. Life-critical medical equipment is medical equipment where failure of such equipment would cause serious bodily injury or death (e.g., life support, pacemakers, defibrillators, heart pumps, neurostimulators, and implantables). Such equipment includes, without limitation, all medical devices identified by the U.S. Food and Drug Administration as Class III devices and equivalent classifications outside the U.S.

TI may expressly designate certain products as completing a particular qualification (e.g., Q100, Military Grade, or Enhanced Product). Designers agree that it has the necessary expertise to select the product with the appropriate qualification designation for their applications and that proper product selection is at Designers' own risk. Designers are solely responsible for compliance with all legal and regulatory requirements in connection with such selection.

Designer will fully indemnify TI and its representatives against any damages, costs, losses, and/or liabilities arising out of Designer's non-compliance with the terms and provisions of this Notice.

## Looking for pricing, stock, or lifecycle information?

Click below to explore more details on WIN SOURCE:

 [View LMH6555SQE/NOPB on WIN SOURCE](#)

 [Texas Instruments](#) Information

## Optimize Your Supply Chain with WIN SOURCE Solutions

-  Global Sourcing Solution
-  Obsolete Management
-  Cost Control Management
-  Shortage Management
-  Alternative Solution
-  Excess Inventory Management