



**THE DATASHEET OF  
TPS3898PDRYT**



## TPS389x Single-Channel, Adjustable Voltage Monitor in Ultra-Small Package

### 1 Features

- Very Small USON (1.45 mm × 1.00 mm) Package
- Adjustable Threshold Down to 500 mV
- Threshold Accuracy: 1% Over Temperature
- Capacitor-Adjustable Delay Time
- Low Quiescent Current: 6  $\mu$ A (Typical)
- External Enable Input
- Open-Drain (Rated at 18 V) and Push-Pull Output Options
- Temperature Range:  $-40^{\circ}\text{C}$  to  $125^{\circ}\text{C}$
- Pin-for-Pin Compatible With MAX6895/6/7/8

### 2 Applications

- DSPs, Microcontrollers, and Microprocessors
- Notebook and Desktop Computers
- PDAs and Handheld Products
- Portable and Battery-Powered Products
- FPGAs and ASICs

### 3 Description

The TPS3895, TPS3896, TPS3897, and TPS3898 devices (TPS389x) are a family of very small supervisory circuits that monitor voltages greater than 500 mV with a 0.25% (typical) threshold accuracy and offer adjustable delay time using external capacitors. The TPS389x family also has a logic enable pin (ENABLE or ENABLE) to power on and off the output. With the TPS3895, for example, when the input voltage pin (SENSE) rises above the threshold, and the ENABLE pin is high, then the output pin (SENSE\_OUT) goes high after the capacitor-adjustable delay time. When SENSE falls below the threshold or ENABLE is low, then SENSE\_OUT goes low. For truth tables, see [Table 1](#) and [Table 2](#).

For TPS389xA versions, both SENSE and ENABLE have a capacitor-adjustable delay. The output asserts after this capacitor-adjustable delay when both SENSE and ENABLE inputs are good. The TPS389xP devices have a small, 0.2- $\mu$ s propagation delay from when the enable pin asserts to when the output pin asserts, provided SENSE is above the threshold.

All devices operate from 1.7 V to 6.5 V and have a typical quiescent current of 6  $\mu$ A with an open-drain output rated at 18 V. The TPS389x is available in an ultra-small USON package and is fully specified over the temperature range of  $T_J = -40^{\circ}\text{C}$  to  $125^{\circ}\text{C}$ .

#### Device Information<sup>(1)</sup>

PART NUMBER	PACKAGE	BODY SIZE (NOM)
TPS389x	USON (6)	1.45 mm × 1.00 mm

(1) For all available packages, see the orderable addendum at the end of the data sheet.

#### Sense Threshold Voltage vs Temperature

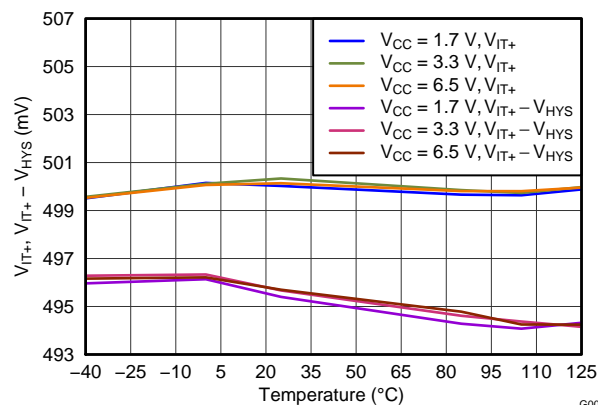

G004



## Table of Contents

<b>1 Features</b> .....	<b>1</b>	8.3 Feature Description .....	14
<b>2 Applications</b> .....	<b>1</b>	8.4 Device Functional Modes .....	15
<b>3 Description</b> .....	<b>1</b>	<b>9 Applications and Implementation</b> .....	<b>16</b>
<b>4 Revision History</b> .....	<b>2</b>	9.1 Application Information .....	16
<b>5 Device Comparison Table</b> .....	<b>3</b>	9.2 Typical Applications .....	16
<b>6 Pin Configuration and Functions</b> .....	<b>4</b>	<b>10 Power Supply Recommendations</b> .....	<b>23</b>
<b>7 Specifications</b> .....	<b>5</b>	<b>11 Layout</b> .....	<b>23</b>
7.1 Absolute Maximum Ratings .....	5	11.1 Layout Guidelines .....	23
7.2 ESD Ratings .....	5	11.2 Layout Example .....	23
7.3 Recommended Operating Conditions .....	5	<b>12 Device and Documentation Support</b> .....	<b>24</b>
7.4 Thermal Information .....	5	12.1 Device Support .....	24
7.5 Electrical Characteristics .....	6	12.2 Documentation Support .....	24
7.6 Timing Requirements .....	7	12.3 Trademarks .....	24
7.7 Typical Characteristics .....	9	12.4 Electrostatic Discharge Caution .....	24
<b>8 Detailed Description</b> .....	<b>12</b>	12.5 Glossary .....	24
8.1 Overview .....	12	<b>13 Mechanical, Packaging, and Orderable Information</b> .....	<b>24</b>
8.2 Functional Block Diagram .....	12		

## 4 Revision History

Changes from Revision A (September 2011) to Revision B	Page
• Added <i>ESD Ratings</i> table, <i>Feature Description</i> section, <i>Device Functional Modes</i> , <i>Application and Implementation</i> section, <i>Power Supply Recommendations</i> section, <i>Layout</i> section, <i>Device and Documentation Support</i> section, and <i>Mechanical, Packaging, and Orderable Information</i> section .....	1
• Changed paragraph 1 of <i>Description</i> section; revised for clarification .....	1
• Changed <i>Pin Configuration and Functions</i> section; updated table format, renamed pin packages to meet new standards .....	4

## 5 Device Comparison Table

DEVICE	ENABLE	OUTPUT	INPUT (SENSE) DELAY	ENABLE DELAY
TPS3895A	Active high	Active high, push-pull	Capacitor adjustable	Capacitor adjustable
TPS3895P	Active high	Active high, push-pull	Capacitor adjustable	0.2 $\mu$ s
TPS3896A	Active low	Active low, push-pull	Capacitor adjustable	Capacitor adjustable
TPS3896P	Active low	Active low, push-pull	Capacitor adjustable	0.2 $\mu$ s
TPS3897A	Active high	Active high, open drain	Capacitor adjustable	Capacitor adjustable
TPS3897P	Active high	Active high, open drain	Capacitor adjustable	0.2 $\mu$ s
TPS3898A	Active low	Active low, open drain	Capacitor adjustable	Capacitor adjustable
TPS3898P	Active low	Active low, open drain	Capacitor adjustable	0.2 $\mu$ s

## 6 Pin Configuration and Functions

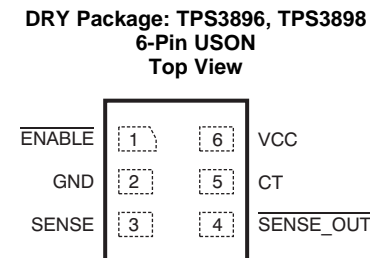
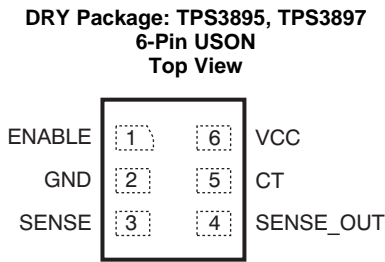

### Pin Functions

NAME	PIN		I/O	DESCRIPTION
	USON			
	TPS3895/ TPS3897	TPS3896/ TPS3898		
CT	5	5	I	Capacitor-adjustable delay. The CT pin offers a user-adjustable delay time. Connecting this pin to a ground referenced capacitor sets the delay time for SENSE rising above 0.5 V to SENSE_OUT asserting (or ENABLE asserting to SENSE_OUT asserting for A version devices). $t_{pd(t)} (s) = [C_{CT} (\mu F) \times 4] + 40 \mu s$
ENABLE	1	—	I	Active high input. Driving ENABLE low immediately makes SENSE_OUT go low, independent of $V_{(SENSE)}$ . With $V_{(SENSE)}$ already above $V_{IT+}$ , drive ENABLE high to make SENSE_OUT go high after the capacitor-adjustable delay time (A version) or 0.2 $\mu s$ (P version).
$\overline{ENABLE}$	—	1	I	Active low input. Driving $\overline{ENABLE}$ high immediately makes $\overline{SENSE\_OUT}$ go high, independent of $V_{(SENSE)}$ . With $V_{(SENSE)}$ already above $V_{IT+}$ , drive $\overline{ENABLE}$ low to make SENSE_OUT go low after the capacitor-adjustable delay time (A version) or 0.2 $\mu s$ (P version).
GND	2	2	—	Ground
SENSE	3	3	I	This pin is connected to the voltage that is monitored with the use of an external resistor. The output asserts after the capacitor-adjustable delay time when $V_{(SENSE)}$ rises above 0.5 V and ENABLE is asserted. The output deasserts after a minimal propagation delay (16 $\mu s$ ) when $V_{(SENSE)}$ falls below $V_{IT+} - V_{hys}$ .
SENSE_OUT	4	—	O	SENSE_OUT is an open-drain and push-pull output that is immediately driven low after $V_{(SENSE)}$ falls below $(V_{IT+} - V_{hys})$ or the ENABLE input is low. SENSE_OUT goes high after the capacitor-adjustable delay time when $V_{(SENSE)}$ is greater than $V_{IT+}$ and the ENABLE pin is high. Open-drain devices (TPS3897/8) can be pulled up to 18 V independent of $V_{CC}$ ; pullup resistors are required for these devices.
$\overline{SENSE\_OUT}$	—	4	O	$\overline{SENSE\_OUT}$ is an open-drain and push-pull output that is immediately driven high after $V_{(SENSE)}$ falls below $(V_{IT+} - V_{hys})$ or the ENABLE input is high. SENSE_OUT goes low after the capacitor-adjustable delay time when $V_{(SENSE)}$ is greater than $V_{IT+}$ and the ENABLE pin is low. Open-drain devices (TPS3897/8) can be pulled up to 18 V independent of $V_{CC}$ ; pullup resistors are required for these devices.
VCC	6	6	I	Supply voltage input. Connect a 1.7-V to 6.5-V supply to VCC to power the device. It is good analog design practice to place a 0.1- $\mu F$ ceramic capacitor close to this pin.

## 7 Specifications

### 7.1 Absolute Maximum Ratings

Over operating free-air temperature range (unless otherwise noted).<sup>(1)</sup>

		MIN	MAX	UNIT
Voltage <sup>(2)</sup>	VCC	-0.3	7	V
	CT	-0.3	V <sub>CC</sub> + 0.3	
	ENABLE, SENSE, SENSE_OUT (push-pull)	-0.3	7	
	SENSE_OUT (open drain)	-0.3	20	
	SENSE_OUT (push-pull)	-0.3	7	
Current	SENSE_OUT		±10	mA
Temperature	Operating junction, T <sub>J</sub>	-40	125	°C
	Storage, T <sub>stg</sub>	-65	150	

- (1) Stresses beyond those listed under *Absolute Maximum Ratings* may cause permanent damage to the device. These are stress ratings only, and functional operation of the device at these or any other conditions beyond those indicated under *Recommended Operating Conditions* is not implied. Exposure to absolute-maximum-rated conditions for extended periods may affect device reliability.
- (2) All voltages are with respect to network ground terminal.

### 7.2 ESD Ratings

		VALUE	UNIT
V <sub>(ESD)</sub> Electrostatic discharge	Human body model (HBM), per ANSI/ESDA/JEDEC JS-001, all pins <sup>(1)</sup>	±2000	V
	Charged device model (CDM), per JEDEC specification JESD22-C101, all pins <sup>(2)</sup>	±500	

- (1) JEDEC document JEP155 states that 500-V HBM allows safe manufacturing with a standard ESD control process.
- (2) JEDEC document JEP157 states that 250-V CDM allows safe manufacturing with a standard ESD control process.

### 7.3 Recommended Operating Conditions

over operating free-air temperature range (unless otherwise noted)

		MIN	NOM	MAX	UNIT
V <sub>CC</sub>	Input supply voltage	1.7		6.5	V
V <sub>ENABLE</sub> , V <sub>ENABLE</sub>	ENABLE and $\overline{\text{ENABLE}}$ pin voltage	0		6.5	V
V <sub>SENSE</sub>	SENSE pin voltage	0		6.5	V
V <sub>SENSE_OUT</sub> , V <sub>SENSE_OUT</sub> (open drain)	SENSE_OUT, $\overline{\text{SENSE\_OUT}}$ pin voltage	0		18	V
V <sub>SENSE_OUT</sub> , V <sub>SENSE_OUT</sub> (push-pull)	SENSE_OUT, $\overline{\text{SENSE\_OUT}}$ pin voltage	0		V <sub>CC</sub>	V
I <sub>SENSE_OUT</sub> , I <sub>SENSE_OUT</sub>	SENSE_OUT, $\overline{\text{SENSE\_OUT}}$ pin current	0.0003		1	mA

### 7.4 Thermal Information

THERMAL METRIC <sup>(1)</sup>		TPS389x	UNIT
		DRY (USON)	
		6 PINS	
R <sub>θJA</sub>	Junction-to-ambient thermal resistance	293.8	°C/W
R <sub>θJC(top)</sub>	Junction-to-case (top) thermal resistance	165.1	
R <sub>θJB</sub>	Junction-to-board thermal resistance	160.8	
Ψ <sub>JT</sub>	Junction-to-top characterization parameter	27.3	
Ψ <sub>JB</sub>	Junction-to-board characterization parameter	65.8	
R <sub>θJC(bot)</sub>	Junction-to-case (bottom) thermal resistance	65.8	

- (1) For more information about traditional and new thermal metrics, see the *IC Package Thermal Metrics* application report, [SPRA953](#).

## 7.5 Electrical Characteristics

Over the operating temperature range of  $T_J = -40^\circ\text{C}$  to  $125^\circ\text{C}$ , and  $1.7\text{ V} < V_{CC} < 6.5\text{ V}$ , unless otherwise noted. Typical values are at  $T_J = 25^\circ\text{C}$  and  $V_{CC} = 3.3\text{ V}$ .

PARAMETER		TEST CONDITIONS	MIN	TYP	MAX	UNIT
$V_{CC}$	Supply voltage range	$T_J = -40^\circ\text{C}$ to $125^\circ\text{C}$	1.7		6.5	V
		$T_J = 0^\circ\text{C}$ to $85^\circ\text{C}$	1.65		6.5	
$V_{(POR)}$	Power-on reset voltage <sup>(1)</sup>	$V_{OL}(\text{max}) = 0.2\text{ V}$ , $I_{(\text{SENSE\_OUT})} = 15\ \mu\text{A}$			0.8	V
$I_{CC}$	Supply current (into VCC pin)	$V_{CC} = 3.3\text{ V}$ , no load		6	12	$\mu\text{A}$
		$V_{CC} = 6.5\text{ V}$ , no load		7	12	
$V_{IT+}$	Positive-going input threshold voltage	$V_{(\text{SENSE})}$ rising	0.495	0.5	0.505	V
$V_{hys}$	Hysteresis voltage	$V_{(\text{SENSE})}$ falling		5		mV
$I_{(\text{SENSE})}$	Input current <sup>(2)</sup>	$V_{(\text{SENSE})} = 0\text{ V}$ or $V_{CC}$	-15		15	nA
$I_{(CT)}$	CT pin charge current		260	310	360	nA
$V_{(CT)}$	CT pin comparator threshold voltage		1.18	1.238	1.299	V
$R_{(CT)}$	CT pin pulldown resistance			200		$\Omega$
$V_{IL}$	Low-level input voltage (ENABLE pin)				0.4	V
$V_{IH}$	High-level input voltage (ENABLE pin)		1.4			V
UVLO	Undervoltage lockout <sup>(3)</sup>	$V_{CC}$ falling	1.3		1.7	V
$I_{lkg}$	Leakage current	ENABLE = $V_{CC}$ or GND	-100		100	nA
$V_{OL}$	Low-level output voltage	$V_{CC} \geq 1.2\text{ V}$ , $I_{\text{SINK}} = 90\ \mu\text{A}$ (TPS3895/7 only)			0.3	V
		$V_{CC} \geq 2.25\text{ V}$ , $I_{\text{SINK}} = 0.5\text{ mA}$			0.3	
		$V_{CC} \geq 4.5\text{ V}$ , $I_{\text{SINK}} = 1\text{ mA}$			0.4	
$V_{OH}$	High-level output voltage (push-pull)	$V_{CC} \geq 2.25\text{ V}$ , $I_{\text{SOURCE}} = 0.5\text{ mA}$	$0.8V_{CC}$			V
		$V_{CC} \geq 4.5\text{ V}$ , $I_{\text{SOURCE}} = 1\text{ mA}$	$0.8V_{CC}$			
$I_{lkg(OD)}$	Open-drain output leakage current	$V_{(\text{SENSE\_OUT})}$ high impedance = 18 V			300	nA

- (1) The lowest supply voltage ( $V_{CC}$ ) at which output is active (SENSE\_OUT is low,  $\overline{\text{SENSE\_OUT}}$  is high);  $t_r(V_{CC}) > 15\ \mu\text{s/V}$ . Below  $V_{(POR)}$ , the output cannot be determined.
- (2) Specified by design.
- (3) When  $V_{CC}$  falls below the UVLO threshold, the output deasserts (SENSE\_OUT goes low,  $\overline{\text{SENSE\_OUT}}$  goes high). Below  $V_{(POR)}$ , the output cannot be determined.

### 7.6 Timing Requirements

		MIN	TYP	MAX	UNIT
$t_{pd(r)}$	SENSE (rising) to SENSE_OUT propagation delay	$V_{(SENSE)}$ rising, $C_{(CT)} =$ open		40	$\mu$ s
		$V_{(SENSE)}$ rising, $C_{(CT)} = 0.047 \mu$ F		190	ms
$t_{pd(f)}$	SENSE (falling) to SENSE_OUT propagation delay	$V_{(SENSE)}$ falling		16	$\mu$ s
	Start-up delay <sup>(1)</sup>			50	$\mu$ s
$t_w$	ENABLE pin minimum pulse duration	1			$\mu$ s
	ENABLE pin glitch rejection			100	ns
$t_{d(OFF)}$	ENABLE to SENSE_OUT delay time (output disabled)	ENABLE deasserted to output deasserted		200	ns
$t_{d(P)}$	ENABLE to SENSE_OUT delay time (P version)	ENABLE asserted to output asserted delay (P version)		200	ns
$t_{d(A)}$	ENABLE to SENSE_OUT delay time (A version)	ENABLE asserted to output asserted delay (A version), $C_{(CT)} =$ open		20	$\mu$ s
		ENABLE asserted to output asserted delay (A version), $C_{(CT)} = 0.047 \mu$ F		190	ms

(1) During power on,  $V_{CC}$  must exceed 1.7 V for at least 50  $\mu$ s (plus propagation delay time,  $t_{pd(r)}$ ) before output is in the correct state.

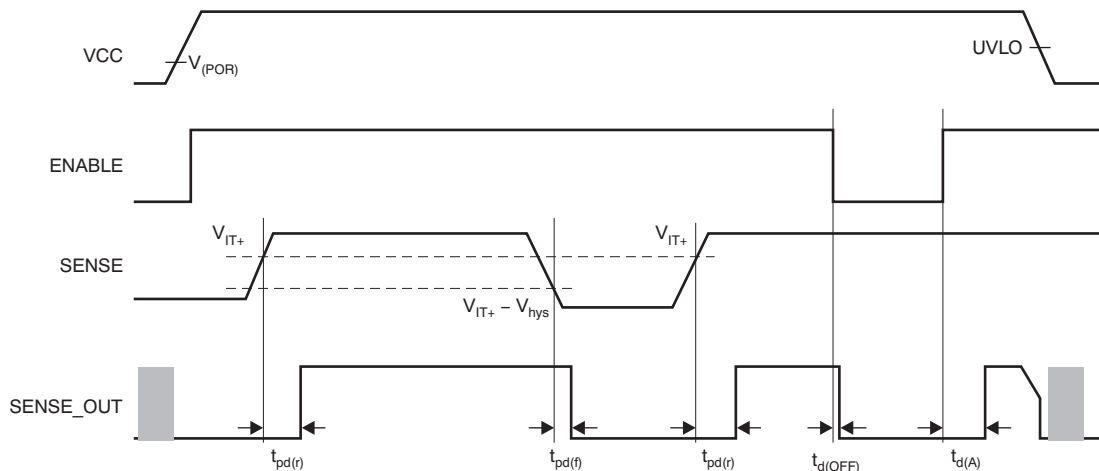
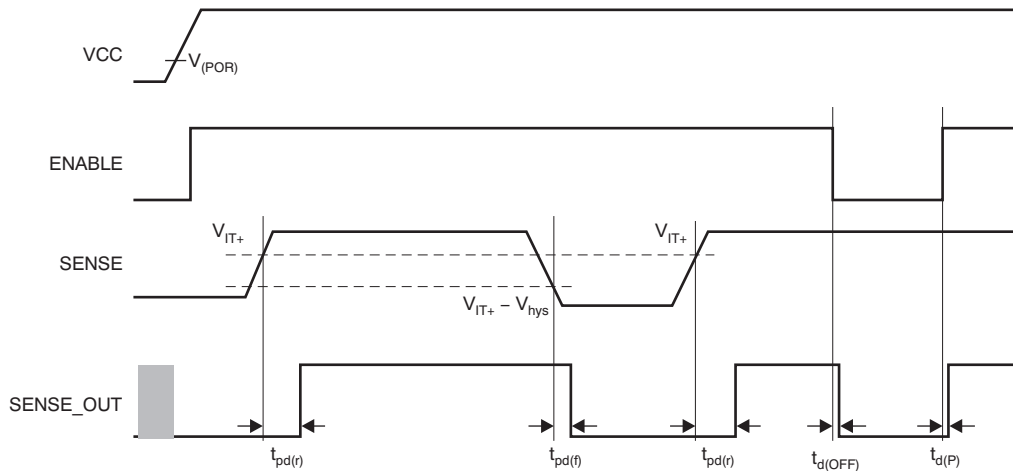
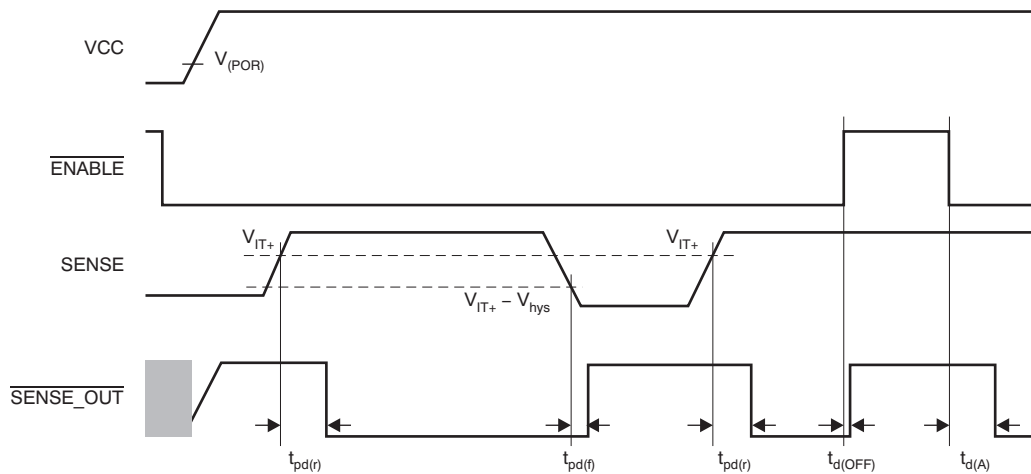
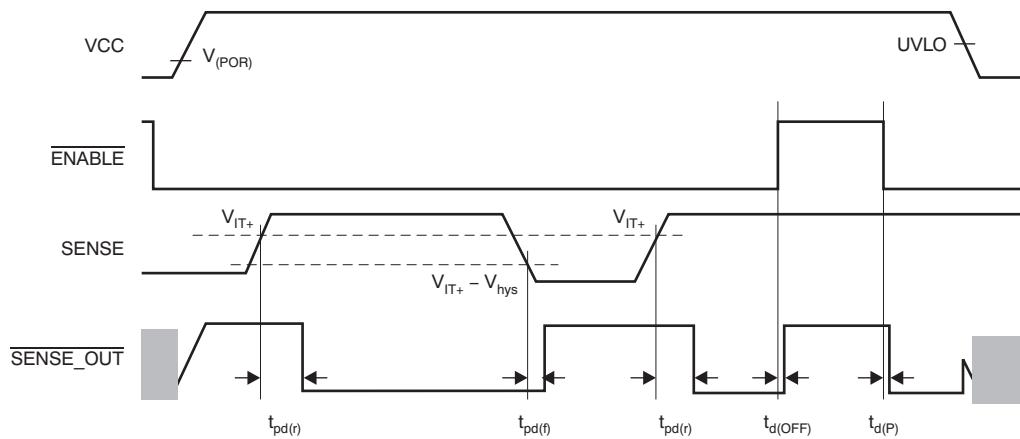

Figure 1. TPS3895A and TPS3897A Timing

**Figure 2. TPS3895P and TPS3897P Timing**

**Figure 3. TPS3896A and TPS3898A Timing**

**Figure 4. TPS3896P and TPS3898P Timing**

### 7.7 Typical Characteristics

At  $T_A = 25^\circ\text{C}$ , and  $V_{CC} = 3.3\text{ V}$ , unless otherwise noted.

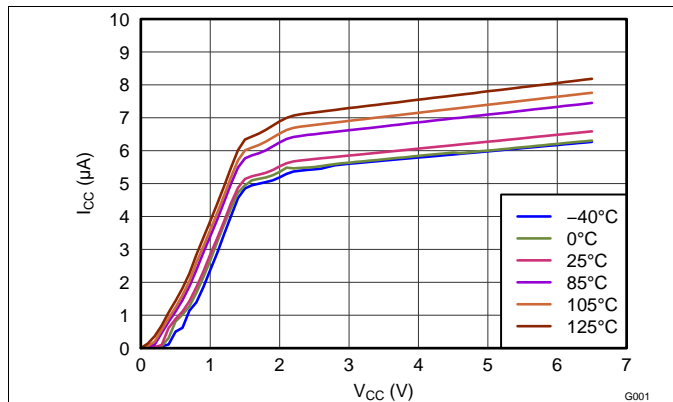

Figure 5. Supply Current vs Supply Voltage

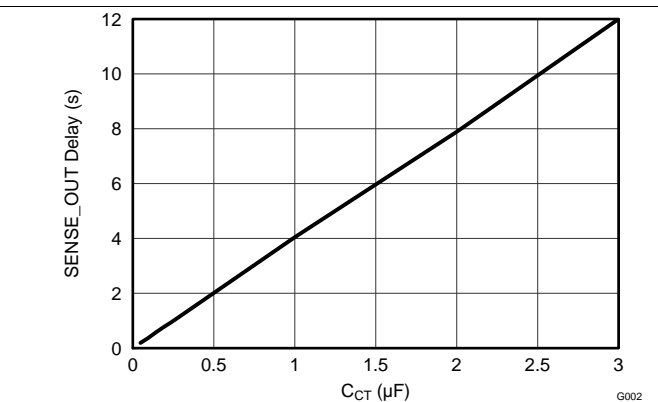

Figure 6. SENSE\_OUT Time-Out Period vs  $C_{CT}$

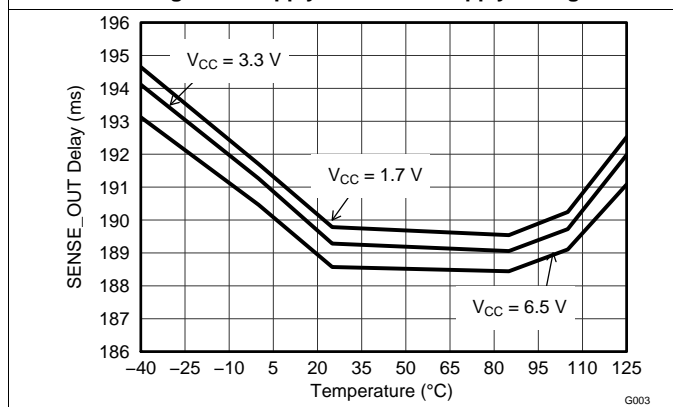

Figure 7. SENSE\_OUT Time-Out Period vs Temperature ( $C_{CT} = 47\text{ nF}$ )

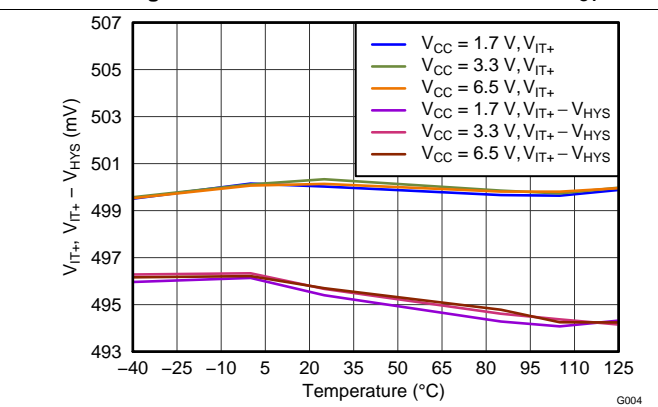

Figure 8. SENSE Threshold Voltage vs Temperature

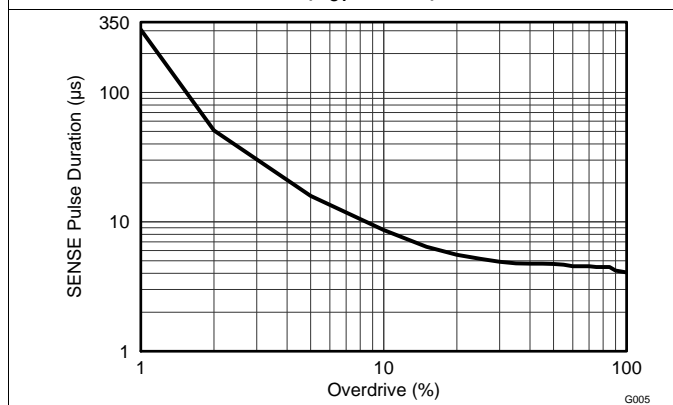

Figure 9. SENSE Minimum Pulse Duration vs SENSE Threshold Overdrive Voltage

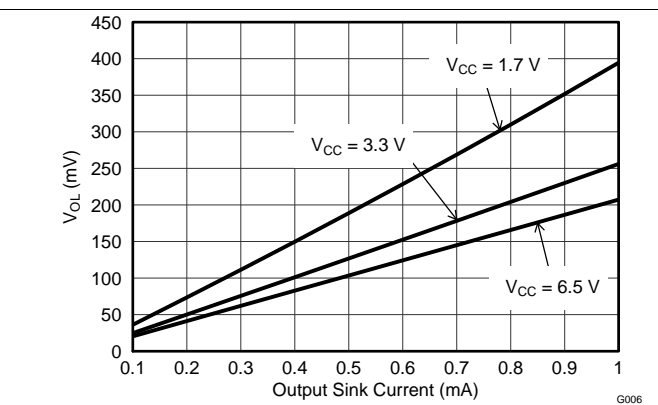

Figure 10. Output Voltage Low vs Output Current (0 mA to 1 mA)

Typical Characteristics (continued)

At  $T_A = 25^\circ\text{C}$ , and  $V_{CC} = 3.3\text{ V}$ , unless otherwise noted.

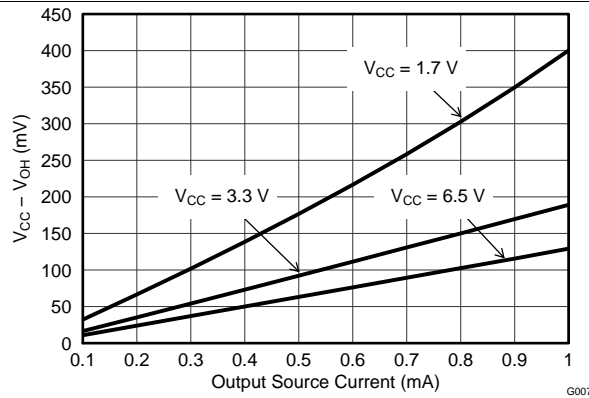

Figure 11. Output Voltage High vs Output Current (0 mA to 1 mA)

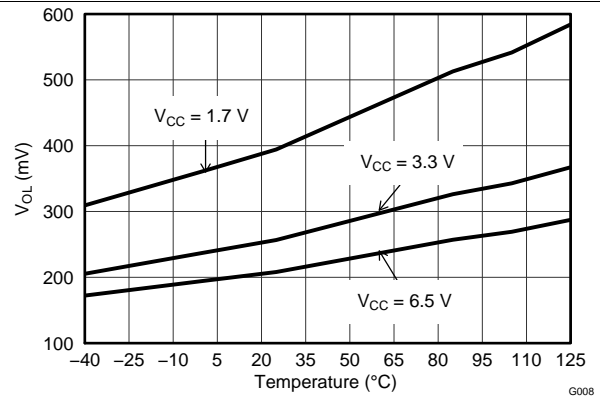

Figure 12. Output Voltage Low at 1 mA vs Temperature

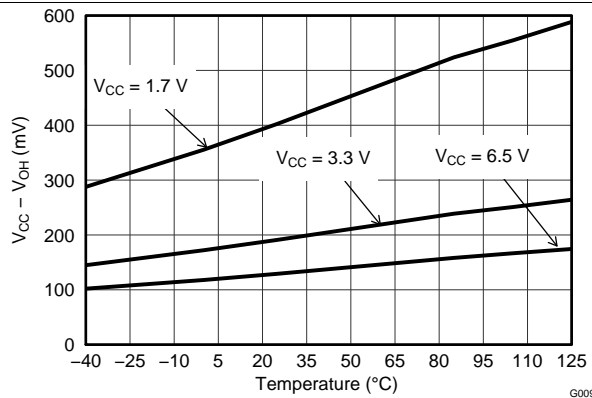

Figure 13. Output Voltage High at 1 mA vs Temperature

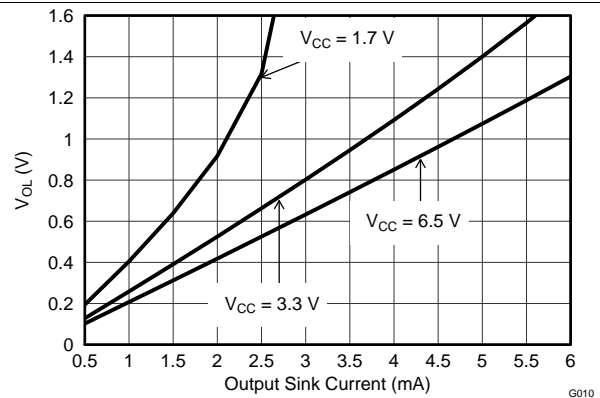

Figure 14. Output Voltage Low vs Output Current

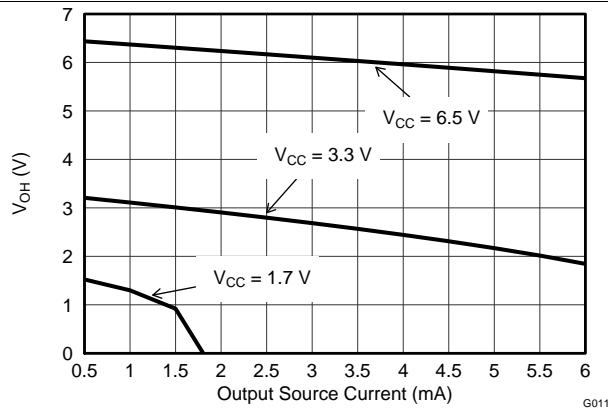

Figure 15. Output Voltage High vs Output Current

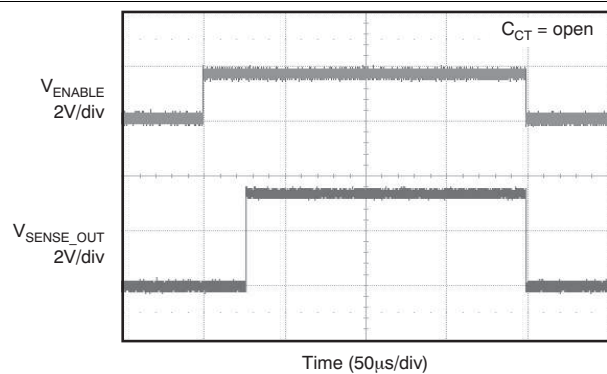
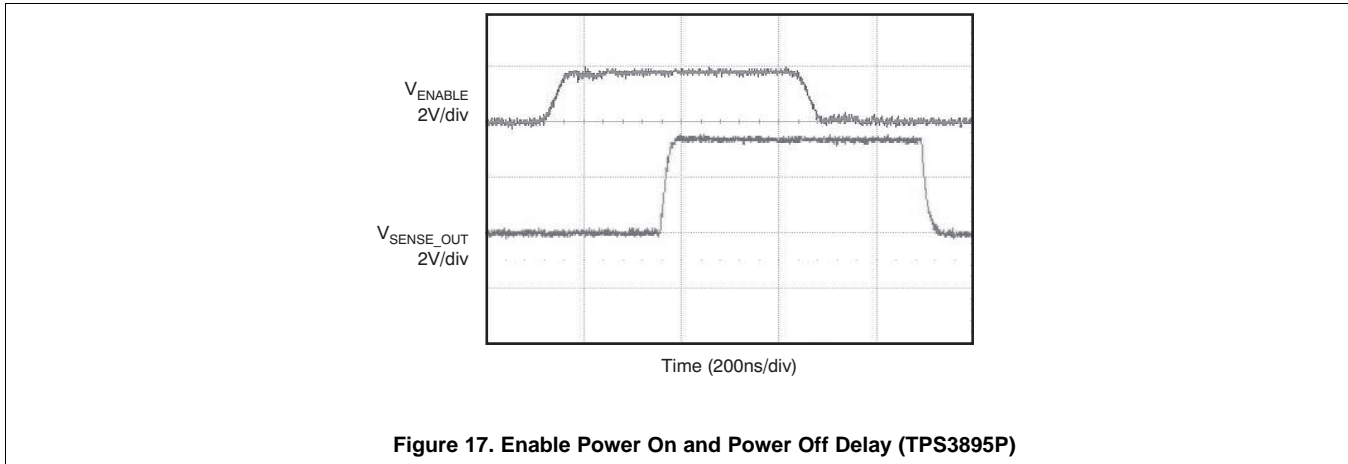

Figure 16. Enable Power On and Power Off Delay (TPS3895A)

**Typical Characteristics (continued)**

At  $T_A = 25^\circ\text{C}$ , and  $V_{CC} = 3.3\text{ V}$ , unless otherwise noted.



## 8 Detailed Description

### 8.1 Overview

The TPS3895, TPS3896, TPS3897, and TPS3898 devices (TPS389x) are a family of ultra-small supervisory circuits. The TPS389x is designed to assert the SENSE\_OUT or  $\overline{\text{SENSE\_OUT}}$  signal, as shown in [Table 1](#) and [Table 2](#). When the SENSE pin rises above 0.5 V and the enable input is asserted (ENABLE = high or  $\overline{\text{ENABLE}}$  = low), the output asserts (SENSE\_OUT goes high or  $\overline{\text{SENSE\_OUT}}$  goes low) after the capacitor-adjustable delay time. The SENSE pin can be set to any voltage threshold above 0.5 V using an external resistor divider. A broad range of output delay times and voltage thresholds can be supported, allowing these devices to be used in wide array of applications.

**Table 1. TPS3895/7 Truth Table**

CONDITIONS		OUTPUT	STATUS
ENABLE = high	SENSE < $V_{IT+}$	SENSE_OUT = low	Output not asserted
ENABLE = low	SENSE < $V_{IT+}$	SENSE_OUT = low	Output not asserted
ENABLE = low	SENSE > $V_{IT+}$	SENSE_OUT = low	Output not asserted
ENABLE = high	SENSE > $V_{IT+}$	SENSE_OUT = high	Output asserted after delay

**Table 2. TPS3896/8 Truth Table**

CONDITIONS		OUTPUT	STATUS
$\overline{\text{ENABLE}}$ = low	SENSE < $V_{IT+}$	$\overline{\text{SENSE\_OUT}}$ = high	Output not asserted
$\overline{\text{ENABLE}}$ = high	SENSE < $V_{IT+}$	$\overline{\text{SENSE\_OUT}}$ = high	Output not asserted
$\overline{\text{ENABLE}}$ = high	SENSE > $V_{IT+}$	$\overline{\text{SENSE\_OUT}}$ = high	Output not asserted
$\overline{\text{ENABLE}}$ = low	SENSE > $V_{IT+}$	$\overline{\text{SENSE\_OUT}}$ = low	Output asserted after delay

### 8.2 Functional Block Diagram

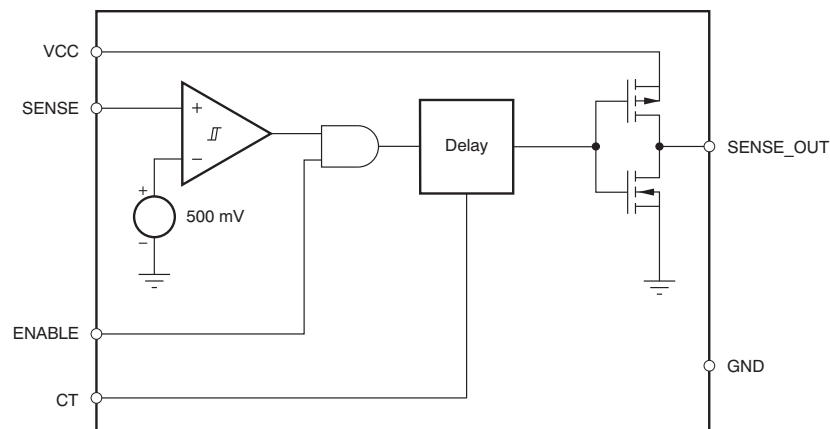

**Figure 18. TPS3895A Block Diagram**

Functional Block Diagram (continued)

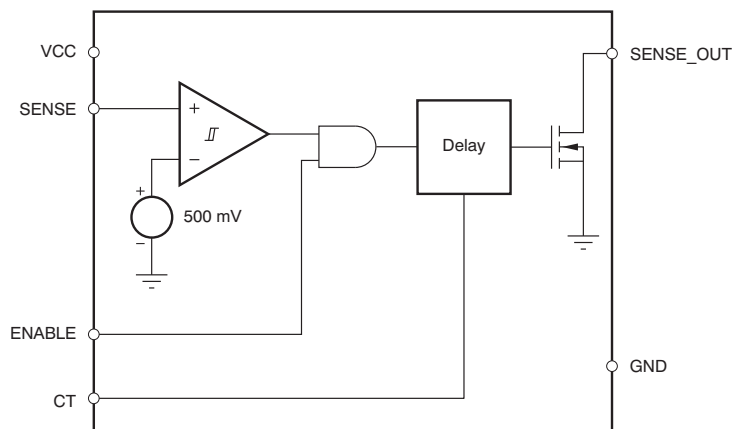

Figure 19. TPS3897A Block Diagram

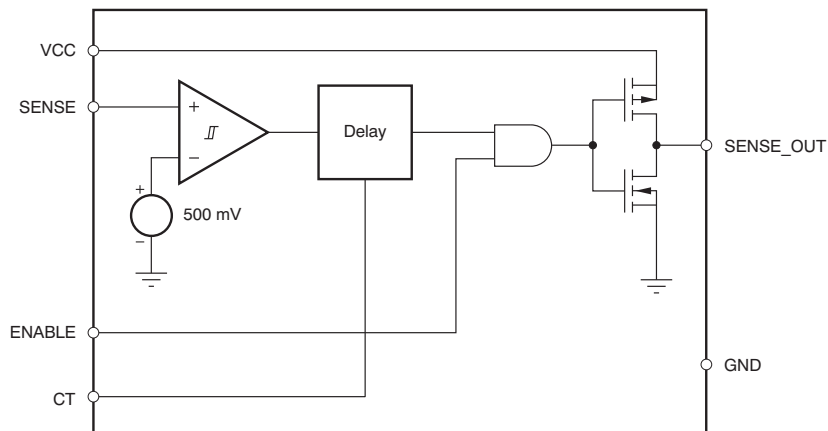

Figure 20. TPS3895P Block Diagram

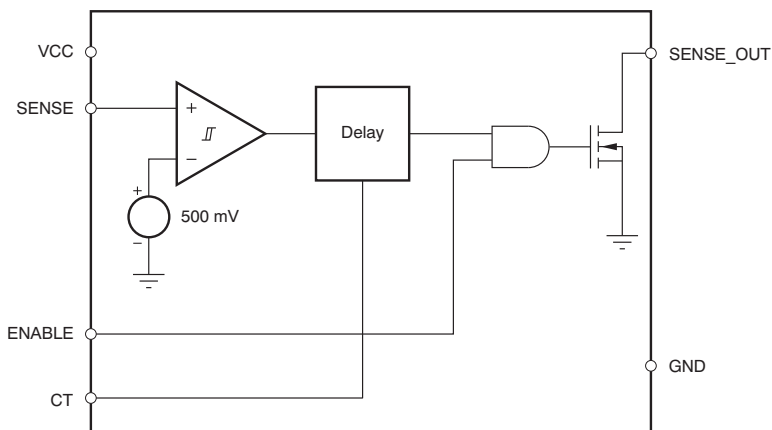

Figure 21. TPS3897P Block Diagram

## 8.3 Feature Description

### 8.3.1 Input Pin (SENSE)

The SENSE input pin allows any system voltage above 0.5 V to be monitored. If the voltage at the SENSE pin exceeds  $V_{IT+}$ , and provided that the enable pin is asserted ( $\text{ENABLE} = \text{high}$  or  $\overline{\text{ENABLE}} = \text{low}$ ), then the output is asserted after the capacitor-adjustable delay time elapses. When the voltage at the SENSE pin drops below  $(V_{IT+} - V_{hys})$ , then the output is deasserted. The comparator has a built-in hysteresis to ensure smooth output assertions and deassertions. Although not required in most cases, for extremely noisy applications, it is good analog design practice to place a 1-nF to 10-nF bypass capacitor at the SENSE input in order to reduce sensitivity to transients and layout parasitics.

The TPS389x family monitor the voltage at SENSE with the use of external resistor divider, as shown in [Figure 22](#).

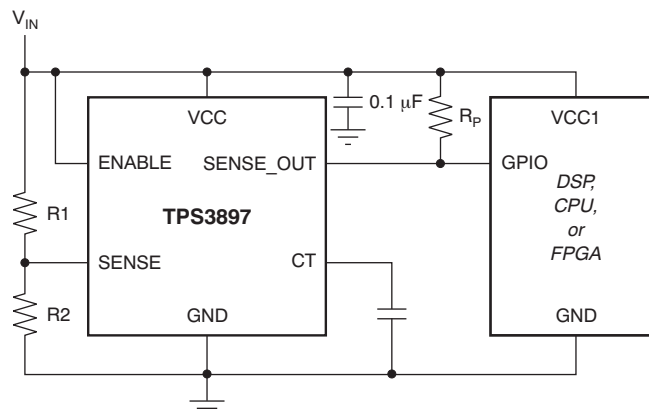

**Figure 22. Using TPS3897 to Monitor User-Defined Threshold Voltage**

The target threshold voltage  $V_{IN}$  can be calculated by using [Equation 1](#):

$$V_{\text{TARGET}} = (1 + R1/R2) \times 0.5 \text{ (V)} \quad (1)$$

When the input voltage ( $V_{IN}$ ) shown in [Figure 22](#) is greater than  $V_{\text{TARGET}}$ , then the output is asserted, provided that the enable pin is asserted ( $\text{ENABLE} = \text{high}$  or  $\overline{\text{ENABLE}} = \text{low}$ ). R1 and R2 can have high values ( $> 100 \text{ k}\Omega$ ) to minimize current consumption as a result of a low SENSE input current without adding significant error to the resistive divider. Refer to application note [SLVA450](#) to learn more about sizing sense-point resistors.

### 8.3.2 Enable Pin (ENABLE)

The enable input allows an external logic signal from other processors, logic circuits, and/or discrete sensors to turn on or turn off the output. The TPS3895 and TPS3897 offer an active-high enable input ( $\text{ENABLE}$ ). The TPS3896 and TPS3898 offer an active-low enable input ( $\overline{\text{ENABLE}}$ ). Driving  $\text{ENABLE}$  low (or  $\overline{\text{ENABLE}}$  high) forces  $\text{SENSE\_OUT}$  to go low (or  $\overline{\text{SENSE\_OUT}}$  to go high). The 0.4-V (maximum) low and 1.4-V (minimum) high allow  $\text{ENABLE}$  to be driven with a 1.5-V or greater system supply.

The TPS389x family is available in two versions: the TPS389xA and TPS389xP. For TPS389xA devices with  $V_{\text{SENSE}} > V_{IT+}$ , driving  $\text{ENABLE}$  high (or  $\overline{\text{ENABLE}} = \text{low}$ ) makes  $\text{SENSE\_OUT}$  go high (or  $\overline{\text{SENSE\_OUT}}$  go low) after the capacitor-adjustable delay time. For the TPS389xP versions with  $V_{\text{SENSE}} > V_{IT+}$ , driving  $\text{ENABLE}$  high (or  $\overline{\text{ENABLE}}$  low) makes  $\text{SENSE\_OUT}$  go high (or  $\overline{\text{SENSE\_OUT}}$  go low) after a 0.2- $\mu\text{s}$  delay.

### 8.3.3 Output Pin (SENSE\_OUT)

In a typical TPS389x application, the  $\text{SENSE\_OUT}$  or  $\overline{\text{SENSE\_OUT}}$  outputs are connected to a reset/enable input of the processor (DSP, CPU, FPGA, ASIC, and so on) or connected to the enable input of a voltage regulator.

## Feature Description (continued)

The TPS3897 and TPS3898 provide open-drain outputs. Pullup resistors must be used to hold these lines high when SENSE\_OUT is asserted or  $\overline{\text{SENSE\_OUT}}$  is not asserted. By connecting the pullup resistors to the proper voltage rails, SENSE\_OUT or  $\overline{\text{SENSE\_OUT}}$  can be connected to other devices at the correct interface voltage levels. The outputs can be pulled up to 18 V independent of the supply voltage ( $V_{CC}$ ). To ensure proper voltage levels, some thought should be given to choosing the correct pullup resistor values. The ability to sink current is determined by the supply voltage; therefore, if  $V_{CC} = 5\text{ V}$  and the desired output pullup is 18 V, then to obtain a sink current of 1 mA or less (as mentioned in the [Electrical Characteristics](#)), the pullup resistor value should be greater than 18 k $\Omega$ . By using wired-OR logic, any combination of SENSE\_OUT can be merged into one logic signal.

The TPS3895 and TPS3896 provide push-pull outputs. The logic high level of the outputs is determined by the VCC pin voltage. With this configuration, pullup resistors are not required and some board area can be saved. However, all the interface logic levels must be examined. All the SENSE\_OUT and  $\overline{\text{SENSE\_OUT}}$  connections must be compatible with the VCC pin logic level.

The SENSE\_OUT or  $\overline{\text{SENSE\_OUT}}$  outputs are defined for a VCC voltage higher than 0.8 V. [Table 1](#) and [Table 2](#) are truth tables that describe how the outputs are asserted or deasserted. When the conditions are met, the device changes state from deasserted to asserted after a preconfigured delay time. However, the transitions from asserted to deasserted are performed almost immediately with minimal propagation delay of 16  $\mu\text{s}$  (typical). [Figure 1](#) to [Figure 4](#) show the timing diagrams and describe the relationship between the threshold voltages ( $V_{IT+}$  and  $V_{hys}$ ), enable inputs, and respective outputs.

### 8.3.4 Output Delay Time Pin (CT)

To program a user-defined, adjustable delay time, an external capacitor must be connected between the CT pin and GND. If the CT pin is left open, there will be a delay of 40  $\mu\text{s}$ . The adjustable delay time can be calculated through [Equation 2](#):

$$t_{pd(r)} (\text{s}) = [C_{CT} (\mu\text{F}) \times 4] + 40 \mu\text{s} \quad (2)$$

The reset delay time is determined by the time it takes an on-chip, precision 310-nA current source to charge the external capacitor to 1.24 V. When  $\text{SENSE} > V_{IT+}$  and with ENABLE high (or  $\overline{\text{ENABLE}}$  low), the internal current sources are enabled and begin to charge the external capacitors. When the CT $n$  voltage on a capacitor reaches 1.24 V, the corresponding SENSE\_OUT or  $\overline{\text{SENSE\_OUT}}$  is asserted. Note that a low-leakage type capacitor (such as ceramic) should be used, and that stray capacitance around this pin may cause errors in the reset delay time.

### 8.3.5 Immunity To Sense Pin Voltage Transients

The TPS389x is relatively immune to short negative transients on the SENSE pin. Sensitivity to transients depends on threshold overdrive, as shown in the typical characteristic graph *Minimum Pulse Duration vs Threshold Overdrive Voltage* ([Figure 9](#)).

## 8.4 Device Functional Modes

### 8.4.1 Normal Operation ( $V_{DD} > V_{DD(\text{min})}$ )

When the voltage on VDD is greater than  $V_{DD(\text{min})}$ , the output corresponds to the voltages on the VDD and ENABLE pins relative to  $V_{IT-}$ .

### 8.4.2 Below $V_{DD(\text{min})}$ ( $V_{(POR)} < V_{DD} < V_{DD(\text{min})}$ )

When the voltage on VDD is less than  $V_{DD(\text{min})}$  but greater than the power-on reset voltage ( $V_{(POR)}$ ), the output is deasserted ( $V_{\text{SENSE\_OUT}}$  is low and  $\overline{V_{\text{SENSE\_OUT}}}$  is high).

### 8.4.3 Below Power-On Reset ( $V_{DD} < V_{(POR)}$ )

When the voltage on VDD is lower than the power-on reset voltage ( $V_{(POR)}$ ), the output is undefined. Do not rely on the output for proper device function under this condition.

## 9 Applications and Implementation

### NOTE

Information in the following applications sections is not part of the TI component specification, and TI does not warrant its accuracy or completeness. TI's customers are responsible for determining suitability of components for their purposes. Customers should validate and test their design implementation to confirm system functionality.

### 9.1 Application Information

The TPS389x family of devices are very small supervisory circuits that monitor voltages greater than 500 mV and offer an adjustable delay time using external capacitors. The TPS389x family operates from 1.7 V to 6.5 V and also has an enable pin to power on/off the output. Orderable options include versions with either push-pull or open-drain outputs as well as versions that use active-high or active-low logic for the output and enable signals.

### 9.2 Typical Applications

#### 9.2.1 Single-Rail Monitoring

The TPS3895P can be used to monitor the supply rail for devices such as digital signal processors (DSPs), central processing units (CPUs), or field-programmable gate arrays (FPGAs). The downstream device is enabled by the TPS3895P once the voltage on the SENSE pin ( $V_{SENSE}$ ) is above the threshold voltage ( $V_{IT+}$ ) set by the resistor divider. The downstream device is disabled by the TPS3895P when  $V_{SENSE}$  falls below the threshold voltage minus the hysteresis voltage ( $V_{IT+} - V_{hys}$ ).

If active low inputs or outputs are needed, replace the TPS3895P devices with TPS3896P devices. [Figure 23](#) shows the TPS3895P in a typical application.

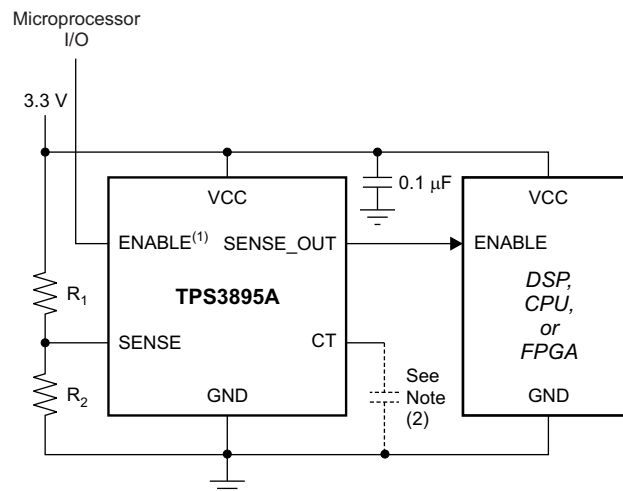

- (1) ENABLE can also be driven with a separate 1.5-V or greater power supply.
- (2) Capacitor is optional. If a capacitor is not used, leave the CT pin open for a 40- $\mu$ s delay.

**Figure 23. TPS3895 Typical Application**

#### 9.2.1.1 Design Requirements

The TPS3895P must drive the enable pin of devices using a logic-high signal to signify that the supply voltage is above the minimum operating voltage of the device.

#### 9.2.1.2 Detailed Design Procedure

Select  $R_1$  and  $R_2$  so the voltage at SENSE ( $V_{SENSE}$ ) is above the positive-going threshold voltage ( $V_{IT+}$ ) at the supply voltage required for proper device operation (that is, proper operation of the DSP, CPU, FPGA, and so on). Also, ensure that the current that flows from the supply voltage to ground through the resistor divider is at least 100 times larger than the input current ( $I_{SENSE}$ ).

## Typical Applications (continued)

If an output delay time is required, connect a capacitor from CT to GND; see the [Output Delay Time Pin \(CT\)](#) section for more information. If no CT cap is connected, the delay time is 40  $\mu$ s.

### 9.2.1.3 Application Curve

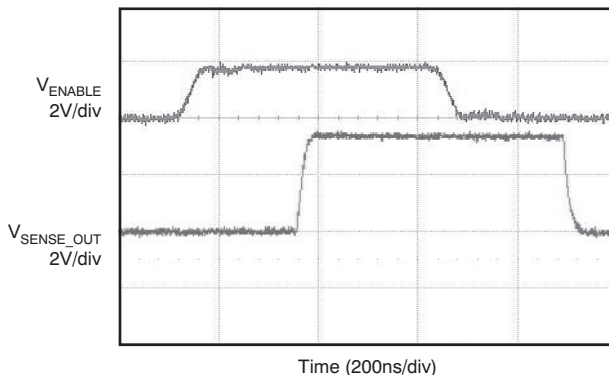

Figure 24. Enable Power On and Power Off Delay (TPS3895P)

### 9.2.2 Multiple Voltage Monitoring Sequential Delay

Multiple TPS3895As can be used to monitor multiple supply rails with a single output signifying whether or not all rails are above the respective thresholds. Some applications may need a minimum total delay time that is the sum of all the delay times of the supply monitor. To achieve this configuration, connect the output of one TPS3895A to the ENABLE pin of the next TPS3895A, and repeat until the last TPS3895A is connected to the device that receives the final Wired-AND signal. The downstream device receives a signal from the last TPS3895A once  $V_{SENSE}$  on all SENSE pins is above the  $V_{IT+}$  set by the resistor dividers. The downstream device is disabled by the last TPS3895A if the voltage on any SENSE pin in the chain falls below  $(V_{IT+} - V_{hys})$ .

Figure 25 shows an example of a configuration for dual-supply monitoring; this concept can be expanded for as many rails as a given application requires.

If active low inputs or outputs are needed, replace the TPS3895A devices with TPS3896A devices.

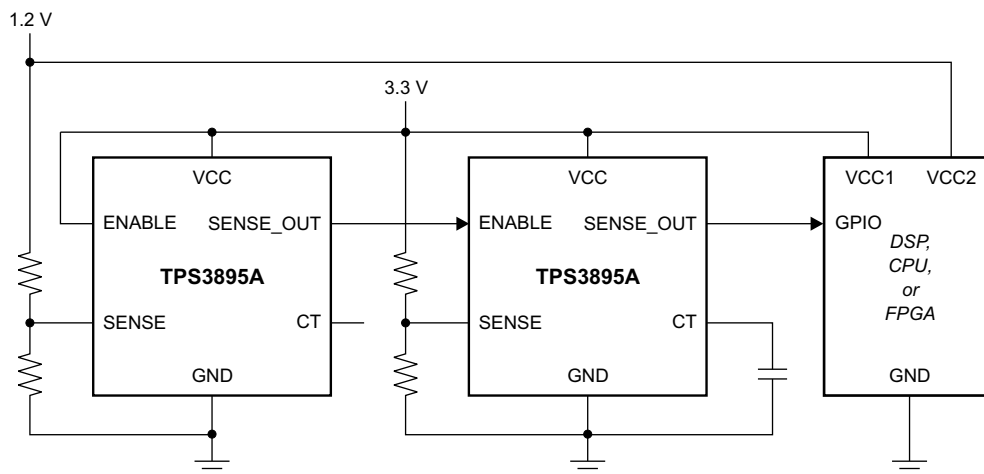

Figure 25. Multiple Voltage Monitoring Using ENABLE Pin

#### 9.2.2.1 Design Requirements

Two rails must be monitored to ensure that both are above the respective minimum operating voltage for proper operation of the device. The TPS3895As must drive a GPIO pin of the final downstream device, and use a logic-high signal to signify that the supply voltages are above the minimum operating voltage of the given device.

## Typical Applications (continued)

### 9.2.2.2 Detailed Design Procedure

Select the resistor divider of each TPS3895A so the voltage at SENSE ( $V_{\text{SENSE}}$ ) is above the positive-going threshold voltage ( $V_{\text{IT+}}$ ) at the point where the monitored voltage is required for proper device operation (that is, proper operation of the DSP, CPU, FPGA, and so on). Also, ensure that the currents that flow from the monitored voltage to ground through the resistor dividers are at least 100 times larger than the input current ( $I_{\text{SENSE}}$ ).

If an output delay time is required for any of the TPS3895As, connect a capacitor from the CT pin of that TPS3895A to GND; see the [Output Delay Time Pin \(CT\)](#) section for more information. If no CT caps are connected, the delay time is 40  $\mu\text{s}$  for each TPS3895A in the chain. Because each of the ENABLE pins is tied to the TPS3895A preceding it (other than the first), at a minimum the total delay time is the sum of all the delay times set by the CT pins in the design.

### 9.2.2.3 Application Curve

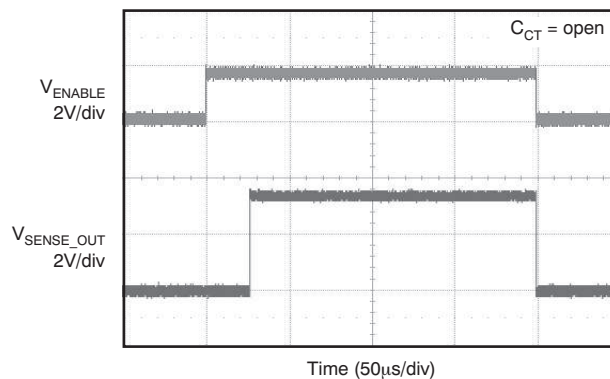

**Figure 26. Enable Power On and Power Off Delay (TPS3895A)**

### 9.2.3 Multiple Voltage Monitoring Minimum Delay

Multiple TPS3897Ps can be used to monitor multiple supply rails with a single output that signals if all rails are above the respective thresholds. Some applications may need a minimum total delay time that is equal to the delay time of only the final supply monitor to power up. To achieve this configuration, connect the outputs of all the TPS3897Ps to the device that must receive the final Wired-AND signal and connect that same node to the appropriate logic-high voltage via a resistor. The downstream device receives a signal once  $V_{\text{SENSE}}$  on all SENSE pins are above the  $V_{\text{IT+}}$  set by the resistor dividers. The downstream device is disabled if the voltage on any SENSE pin falls below ( $V_{\text{IT+}} - V_{\text{hys}}$ ).

See [Figure 27](#) for an example of a configuration for dual-supply monitoring. This concept can be expanded for as many rails as a given application requires.

If active low inputs/outputs are required, replace the TPS3897P devices with TPS3898P devices.

Typical Applications (continued)

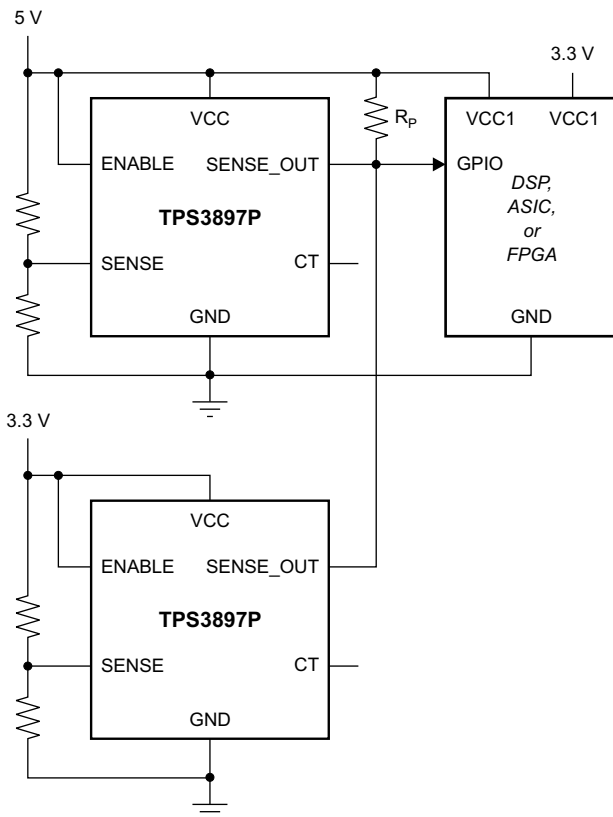

Figure 27. Multiple Voltage Monitoring Using Wired-OR Logic at SENSE\_OUT

9.2.3.1 Design Requirements

Two rails must be monitored to ensure that both rails are above the respective minimum operating voltage for proper operation of the device. The TPS3897Ps must drive a GPIO pin of the final downstream device and use a logic-high signal to signify that the supply voltages are above the minimum operating voltage of the device.

9.2.3.2 Detailed Design Procedure

Select the resistor divider of each TPS3897P so the voltage at SENSE ( $V_{SENSE}$ ) is above the positive-going threshold voltage ( $V_{IT+}$ ) at the point where the monitored voltage is required for proper device operation (that is, proper operation of the DSP, CPU, FPGA, and so on). Also, ensure that the currents that flow from the monitored voltage to ground through the resistor dividers are at least 100 times larger than the input current ( $I_{SENSE}$ ).

If an output delay time is required for any of the TPS3897Ps, connect a capacitor from the CT pin of that TPS3897P to GND; see the *Output Delay Time Pin (CT)* section for more information. If no CT caps are connected, the delay time is 40  $\mu$ s.

Determine the logic-high voltage by selecting the voltage that the pullup resistor (denoted  $R_p$  in Figure 29) is connected to. Select  $R_p$  so that current that flows to ground allows for a low-level output voltage that is low enough for the specific application. See the *Output Pin (SENSE\_OUT)* section for more information.

## Typical Applications (continued)

### 9.2.3.3 Application Curves

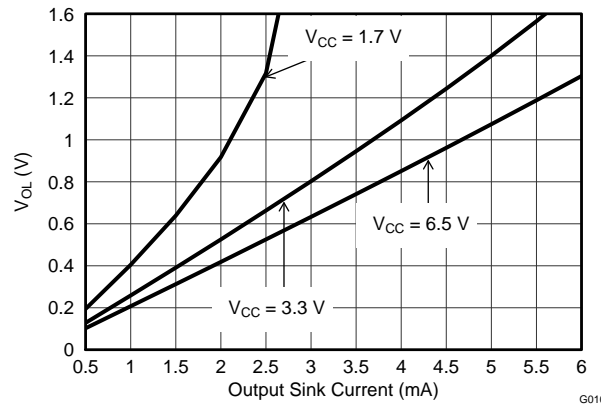

**Figure 28. Output Voltage Low vs Output Current**

### 9.2.4 Voltage Sequencing

TPS3895As can be used to implement voltage rail sequencing by connecting a resistor divider and the SENSE pin of a TPS3895A to the first rail to be monitored, and then feeding the output from the first TPS3895A to the ENABLE pin of the next voltage rail. The downstream voltage rail is enabled by the TPS3895A once the voltage on the SENSE pin ( $V_{SENSE}$ ) is above the threshold voltage ( $V_{IT+}$ ) set by the resistor divider. This process can be repeated for as many rails as the application requires. The downstream voltage rail is disabled by the TPS3895A when  $V_{SENSE}$  falls below the threshold voltage minus the hysteresis voltage ( $V_{IT+} - V_{hys}$ ).

If active low inputs/outputs are required, replace the TPS3895A devices with TPS3896A devices.

See [Figure 29](#) for an example for a system with four voltage rails that must sequence the three LDOs.

Typical Applications (continued)

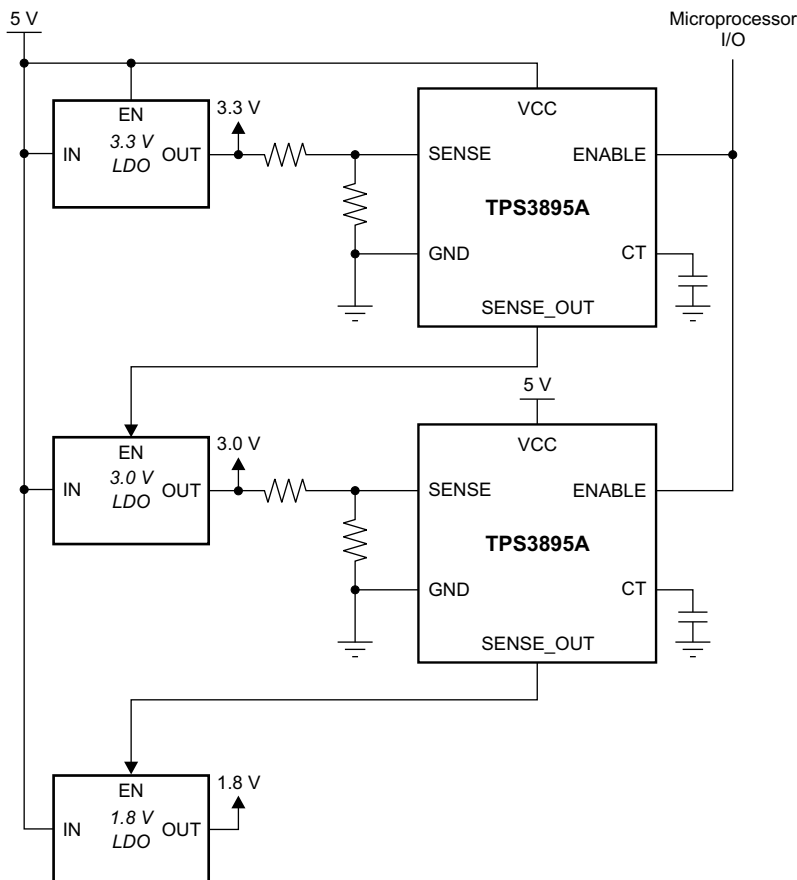

Figure 29. Voltage Sequencing (5 V → 3.3 V → 3 V → 1.8 V)

9.2.4.1 Design Requirements

Three rails must be sequenced to ensure proper start-up sequencing. The TPS3895As must drive the ENABLE pins of each LDO, and use a logic-high signal to signify that the supply preceding it is above the desired operating voltage for that rail. The ENABLE pin of the TPS3895As must be controlled by a microprocessor to allow it to be shut down even when the rails are above the threshold.

9.2.4.2 Detailed Design Procedure

Select the resistor divider of each TPS3895A so the voltage at SENSE ( $V_{SENSE}$ ) is above the positive-going threshold voltage ( $V_{IT+}$ ) at the point where the monitored voltage is required for proper device operation (that is, proper operation of the DSP, CPU, FPGA, and so on). Also, ensure that the currents that flow from the monitored voltage to ground through the resistor dividers are at least 100 times larger than the input current ( $I_{SENSE}$ ).

If an output delay time is required for any of the TPS3895As, connect a capacitor from the CT pin of that TPS3895A to GND; see the *Output Delay Time Pin (CT)* section for more information. If no CT caps are connected, the delay time is 40  $\mu$ s for each TPS3895A in the chain. Because each of the ENABLE pins is tied to the TPS3895A that precedes it (other than the first device in the chain), at a minimum the total delay time is the sum of all the delay times set by the CT pins.

Typical Applications (continued)

9.2.4.3 Application Curve

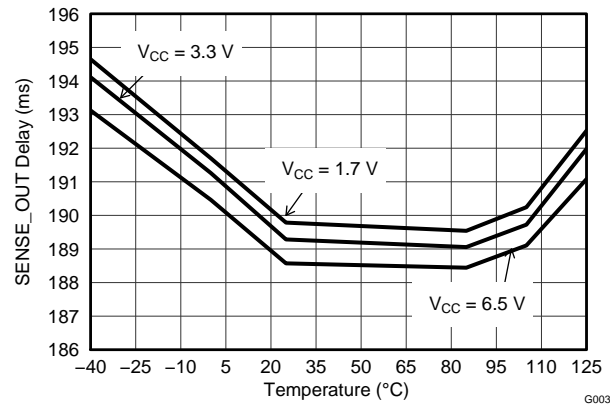

Figure 30. SENSE\_OUT Time-out Period vs Temperature (C<sub>CT</sub> = 47 nF)

## 10 Power Supply Recommendations

These devices are designed to operate from an input supply with a voltage range from 1.7 V to 6.5 V. Though not required, it is good analog design practice to place a 0.1- $\mu\text{F}$  ceramic capacitor close to the VCC pin.

## 11 Layout

### 11.1 Layout Guidelines

Follow these guidelines to lay out the printed-circuit-board (PCB) that is used for the TPS389x family of devices.

- Place the VCC decoupling capacitor close to the device.
- Avoid using long traces for the VCC supply node. The VCC capacitor ( $C_{VCC}$ ), along with parasitic inductance from the supply to the capacitor, can form an LC tank and create ringing with peak voltages above the maximum VCC voltage.

### 11.2 Layout Example

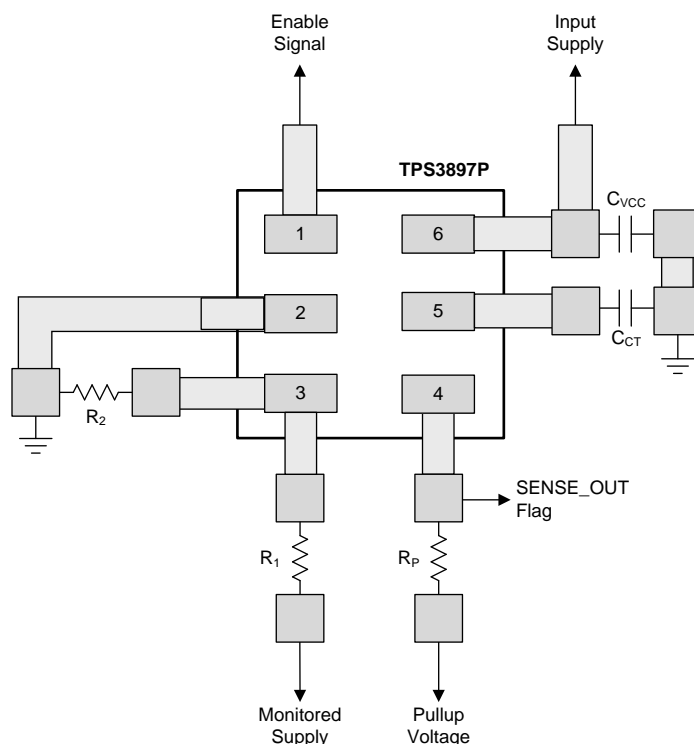

Figure 31. TPS3897P Layout Example (DRY Package)

## 12 Device and Documentation Support

### 12.1 Device Support

#### 12.1.1 Development Support

##### 12.1.1.1 Evaluation Modules

An evaluation module (EVM) is available to assist in the initial circuit performance evaluation using the TPS389x. The [TPS3897A-6P-EVM047 evaluation module](#) (and [related user guide](#)) can be requested at the TI website through the product folders or purchased directly from the [TI eStore](#).

##### 12.1.1.2 Spice Models

Computer simulation of circuit performance using SPICE is often useful when analyzing the performance of analog circuits and systems. SPICE models for the TPS389x are available through the respective device product folders under *Tools & Software*.

#### 12.1.2 Device Nomenclature

**Table 3. Device Nomenclature**

PRODUCT	DESCRIPTION
TPS389wxyyyz	<p>w is output configuration (see <a href="#">Device Comparison Table</a>)</p> <p>x is different delay from enable pin (see <a href="#">Device Comparison Table</a>)</p> <p>yyy is package designator</p> <p>z is package quantity</p>

### 12.2 Documentation Support

#### 12.2.1 Related Documentation

- *Choosing an Appropriate Pullup/Pulldown Resistor for Open Drain Outputs*, [SLVA485](#)
- *TPS3897A-6P-EVM047 User's Guide*, [SLVU524](#)

#### 12.3 Trademarks

All trademarks are the property of their respective owners.

#### 12.4 Electrostatic Discharge Caution



These devices have limited built-in ESD protection. The leads should be shorted together or the device placed in conductive foam during storage or handling to prevent electrostatic damage to the MOS gates.

#### 12.5 Glossary

[SLYZ022](#) — *TI Glossary*.

This glossary lists and explains terms, acronyms, and definitions.

## 13 Mechanical, Packaging, and Orderable Information

The following pages include mechanical, packaging, and orderable information. This information is the most current data available for the designated devices. This data is subject to change without notice and revision of this document. For browser-based versions of this data sheet, refer to the left-hand navigation.

**PACKAGING INFORMATION**

Orderable Device	Status (1)	Package Type	Package Drawing	Pins	Package Qty	Eco Plan (2)	Lead/Ball Finish (6)	MSL Peak Temp (3)	Op Temp (°C)	Device Marking (4/5)	Samples
TPS3895ADRYR	ACTIVE	SON	DRY	6	5000	Green (RoHS & no Sb/Br)	CU NIPDAU   Call TI	Level-1-260C-UNLIM	-40 to 125	UN	<a href="#">Samples</a>
TPS3895ADRYT	ACTIVE	SON	DRY	6	250	Green (RoHS & no Sb/Br)	CU NIPDAU   Call TI	Level-1-260C-UNLIM	-40 to 125	UN	<a href="#">Samples</a>
TPS3895PDRYR	ACTIVE	SON	DRY	6	5000	Green (RoHS & no Sb/Br)	CU NIPDAU	Level-1-260C-UNLIM	-40 to 125	UO	<a href="#">Samples</a>
TPS3895PDRYT	ACTIVE	SON	DRY	6	250	Green (RoHS & no Sb/Br)	CU NIPDAU	Level-1-260C-UNLIM	-40 to 125	UO	<a href="#">Samples</a>
TPS3896ADRYR	ACTIVE	SON	DRY	6	5000	Green (RoHS & no Sb/Br)	CU NIPDAU	Level-1-260C-UNLIM	-40 to 125	UJ	<a href="#">Samples</a>
TPS3896ADRYT	ACTIVE	SON	DRY	6	250	Green (RoHS & no Sb/Br)	CU NIPDAU	Level-1-260C-UNLIM	-40 to 125	UJ	<a href="#">Samples</a>
TPS3896PDRYR	ACTIVE	SON	DRY	6	5000	Green (RoHS & no Sb/Br)	CU NIPDAU	Level-1-260C-UNLIM	-40 to 125	UK	<a href="#">Samples</a>
TPS3896PDRYT	ACTIVE	SON	DRY	6	250	Green (RoHS & no Sb/Br)	CU NIPDAU	Level-1-260C-UNLIM	-40 to 125	UK	<a href="#">Samples</a>
TPS3897ADRYR	ACTIVE	SON	DRY	6	5000	Green (RoHS & no Sb/Br)	CU NIPDAU	Level-1-260C-UNLIM	-40 to 125	UL	<a href="#">Samples</a>
TPS3897ADRYT	ACTIVE	SON	DRY	6	250	Green (RoHS & no Sb/Br)	CU NIPDAU	Level-1-260C-UNLIM	-40 to 125	UL	<a href="#">Samples</a>
TPS3897PDRYR	ACTIVE	SON	DRY	6	5000	Green (RoHS & no Sb/Br)	CU NIPDAU   Call TI	Level-1-260C-UNLIM	-40 to 125	UM	<a href="#">Samples</a>
TPS3897PDRYT	ACTIVE	SON	DRY	6	250	Green (RoHS & no Sb/Br)	CU NIPDAU   Call TI	Level-1-260C-UNLIM	-40 to 125	UM	<a href="#">Samples</a>
TPS3898ADRYR	ACTIVE	SON	DRY	6	5000	Green (RoHS & no Sb/Br)	CU NIPDAU	Level-1-260C-UNLIM	-40 to 125	UH	<a href="#">Samples</a>
TPS3898ADRYT	ACTIVE	SON	DRY	6	250	Green (RoHS & no Sb/Br)	CU NIPDAU	Level-1-260C-UNLIM	-40 to 125	UH	<a href="#">Samples</a>
TPS3898PDRYR	ACTIVE	SON	DRY	6	5000	Green (RoHS & no Sb/Br)	CU NIPDAU	Level-1-260C-UNLIM	-40 to 125	UI	<a href="#">Samples</a>
TPS3898PDRYT	ACTIVE	SON	DRY	6	250	Green (RoHS & no Sb/Br)	CU NIPDAU	Level-1-260C-UNLIM	-40 to 125	UI	<a href="#">Samples</a>

(1) The marketing status values are defined as follows:  
**ACTIVE:** Product device recommended for new designs.

**LIFEBUY:** TI has announced that the device will be discontinued, and a lifetime-buy period is in effect.

**NRND:** Not recommended for new designs. Device is in production to support existing customers, but TI does not recommend using this part in a new design.

**PREVIEW:** Device has been announced but is not in production. Samples may or may not be available.

**OBSELETE:** TI has discontinued the production of the device.

<sup>(2)</sup> **RoHS:** TI defines "RoHS" to mean semiconductor products that are compliant with the current EU RoHS requirements for all 10 RoHS substances, including the requirement that RoHS substance do not exceed 0.1% by weight in homogeneous materials. Where designed to be soldered at high temperatures, "RoHS" products are suitable for use in specified lead-free processes. TI may reference these types of products as "Pb-Free".

**RoHS Exempt:** TI defines "RoHS Exempt" to mean products that contain lead but are compliant with EU RoHS pursuant to a specific EU RoHS exemption.

**Green:** TI defines "Green" to mean the content of Chlorine (Cl) and Bromine (Br) based flame retardants meet JS709B low halogen requirements of  $\leq 1000$ ppm threshold. Antimony trioxide based flame retardants must also meet the  $\leq 1000$ ppm threshold requirement.

<sup>(3)</sup> MSL, Peak Temp. - The Moisture Sensitivity Level rating according to the JEDEC industry standard classifications, and peak solder temperature.

<sup>(4)</sup> There may be additional marking, which relates to the logo, the lot trace code information, or the environmental category on the device.

<sup>(5)</sup> Multiple Device Markings will be inside parentheses. Only one Device Marking contained in parentheses and separated by a "~" will appear on a device. If a line is indented then it is a continuation of the previous line and the two combined represent the entire Device Marking for that device.

<sup>(6)</sup> Lead/Ball Finish - Orderable Devices may have multiple material finish options. Finish options are separated by a vertical ruled line. Lead/Ball Finish values may wrap to two lines if the finish value exceeds the maximum column width.

**Important Information and Disclaimer:** The information provided on this page represents TI's knowledge and belief as of the date that it is provided. TI bases its knowledge and belief on information provided by third parties, and makes no representation or warranty as to the accuracy of such information. Efforts are underway to better integrate information from third parties. TI has taken and continues to take reasonable steps to provide representative and accurate information but may not have conducted destructive testing or chemical analysis on incoming materials and chemicals. TI and TI suppliers consider certain information to be proprietary, and thus CAS numbers and other limited information may not be available for release.

In no event shall TI's liability arising out of such information exceed the total purchase price of the TI part(s) at issue in this document sold by TI to Customer on an annual basis.

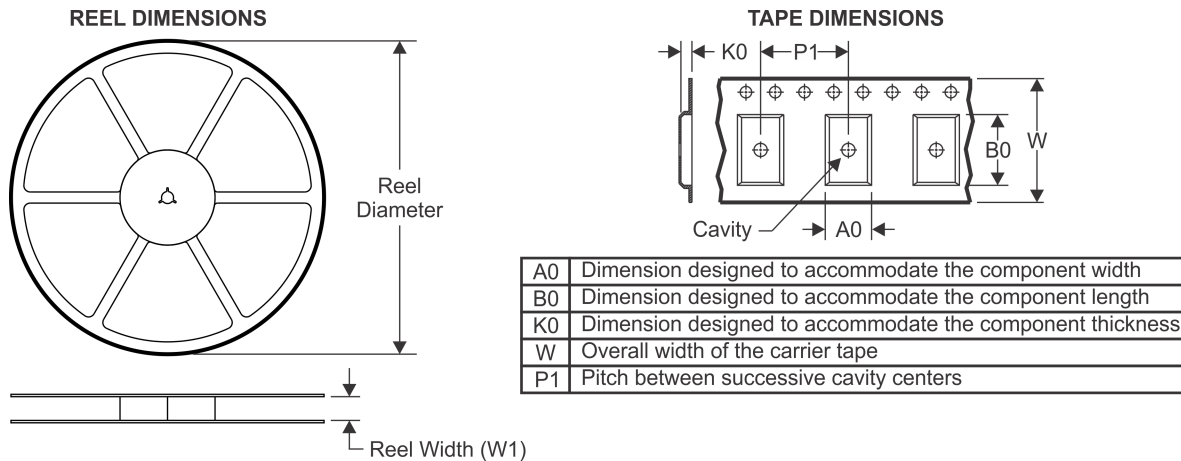
**TAPE AND REEL INFORMATION**

**QUADRANT ASSIGNMENTS FOR PIN 1 ORIENTATION IN TAPE**

\*All dimensions are nominal

Device	Package Type	Package Drawing	Pins	SPQ	Reel Diameter (mm)	Reel Width W1 (mm)	A0 (mm)	B0 (mm)	K0 (mm)	P1 (mm)	W (mm)	Pin1 Quadrant
TPS3895ADRYR	SON	DRY	6	5000	180.0	8.4	1.2	1.65	0.7	4.0	8.0	Q1
TPS3895ADRYT	SON	DRY	6	250	179.0	8.4	1.2	1.65	0.7	4.0	8.0	Q1
TPS3895PDRYR	SON	DRY	6	5000	179.0	8.4	1.2	1.65	0.7	4.0	8.0	Q1
TPS3895PDRYT	SON	DRY	6	250	179.0	8.4	1.2	1.65	0.7	4.0	8.0	Q1
TPS3896ADRYR	SON	DRY	6	5000	179.0	8.4	1.2	1.65	0.7	4.0	8.0	Q1
TPS3896ADRYT	SON	DRY	6	250	179.0	8.4	1.2	1.65	0.7	4.0	8.0	Q1
TPS3896PDRYR	SON	DRY	6	5000	179.0	8.4	1.2	1.65	0.7	4.0	8.0	Q1
TPS3896PDRYT	SON	DRY	6	250	179.0	8.4	1.2	1.65	0.7	4.0	8.0	Q1
TPS3897ADRYR	SON	DRY	6	5000	179.0	8.4	1.2	1.65	0.7	4.0	8.0	Q1
TPS3897ADRYT	SON	DRY	6	250	179.0	8.4	1.2	1.65	0.7	4.0	8.0	Q1
TPS3897PDRYR	SON	DRY	6	5000	179.0	8.4	1.2	1.65	0.7	4.0	8.0	Q1
TPS3897PDRYT	SON	DRY	6	250	179.0	8.4	1.2	1.65	0.7	4.0	8.0	Q1
TPS3898ADRYR	SON	DRY	6	5000	179.0	8.4	1.2	1.65	0.7	4.0	8.0	Q1
TPS3898ADRYT	SON	DRY	6	250	179.0	8.4	1.2	1.65	0.7	4.0	8.0	Q1
TPS3898PDRYR	SON	DRY	6	5000	179.0	8.4	1.2	1.65	0.7	4.0	8.0	Q1
TPS3898PDRYT	SON	DRY	6	250	179.0	8.4	1.2	1.65	0.7	4.0	8.0	Q1

**TAPE AND REEL BOX DIMENSIONS**

\*All dimensions are nominal

Device	Package Type	Package Drawing	Pins	SPQ	Length (mm)	Width (mm)	Height (mm)
TPS3895ADRYR	SON	DRY	6	5000	203.0	203.0	35.0
TPS3895ADRYT	SON	DRY	6	250	203.0	203.0	35.0
TPS3895PDRYR	SON	DRY	6	5000	203.0	203.0	35.0
TPS3895PDRYT	SON	DRY	6	250	203.0	203.0	35.0
TPS3896ADRYR	SON	DRY	6	5000	203.0	203.0	35.0
TPS3896ADRYT	SON	DRY	6	250	203.0	203.0	35.0
TPS3896PDRYR	SON	DRY	6	5000	203.0	203.0	35.0
TPS3896PDRYT	SON	DRY	6	250	203.0	203.0	35.0
TPS3897ADRYR	SON	DRY	6	5000	203.0	203.0	35.0
TPS3897ADRYT	SON	DRY	6	250	203.0	203.0	35.0
TPS3897PDRYR	SON	DRY	6	5000	203.0	203.0	35.0
TPS3897PDRYT	SON	DRY	6	250	203.0	203.0	35.0
TPS3898ADRYR	SON	DRY	6	5000	203.0	203.0	35.0
TPS3898ADRYT	SON	DRY	6	250	203.0	203.0	35.0
TPS3898PDRYR	SON	DRY	6	5000	203.0	203.0	35.0
TPS3898PDRYT	SON	DRY	6	250	203.0	203.0	35.0

## GENERIC PACKAGE VIEW

**DRY 6**

**USON - 0.6 mm max height**

PLASTIC SMALL OUTLINE - NO LEAD



Images above are just a representation of the package family, actual package may vary.  
Refer to the product data sheet for package details.

4207181/G

DRY0006A



# PACKAGE OUTLINE

USON - 0.6 mm max height

PLASTIC SMALL OUTLINE - NO LEAD

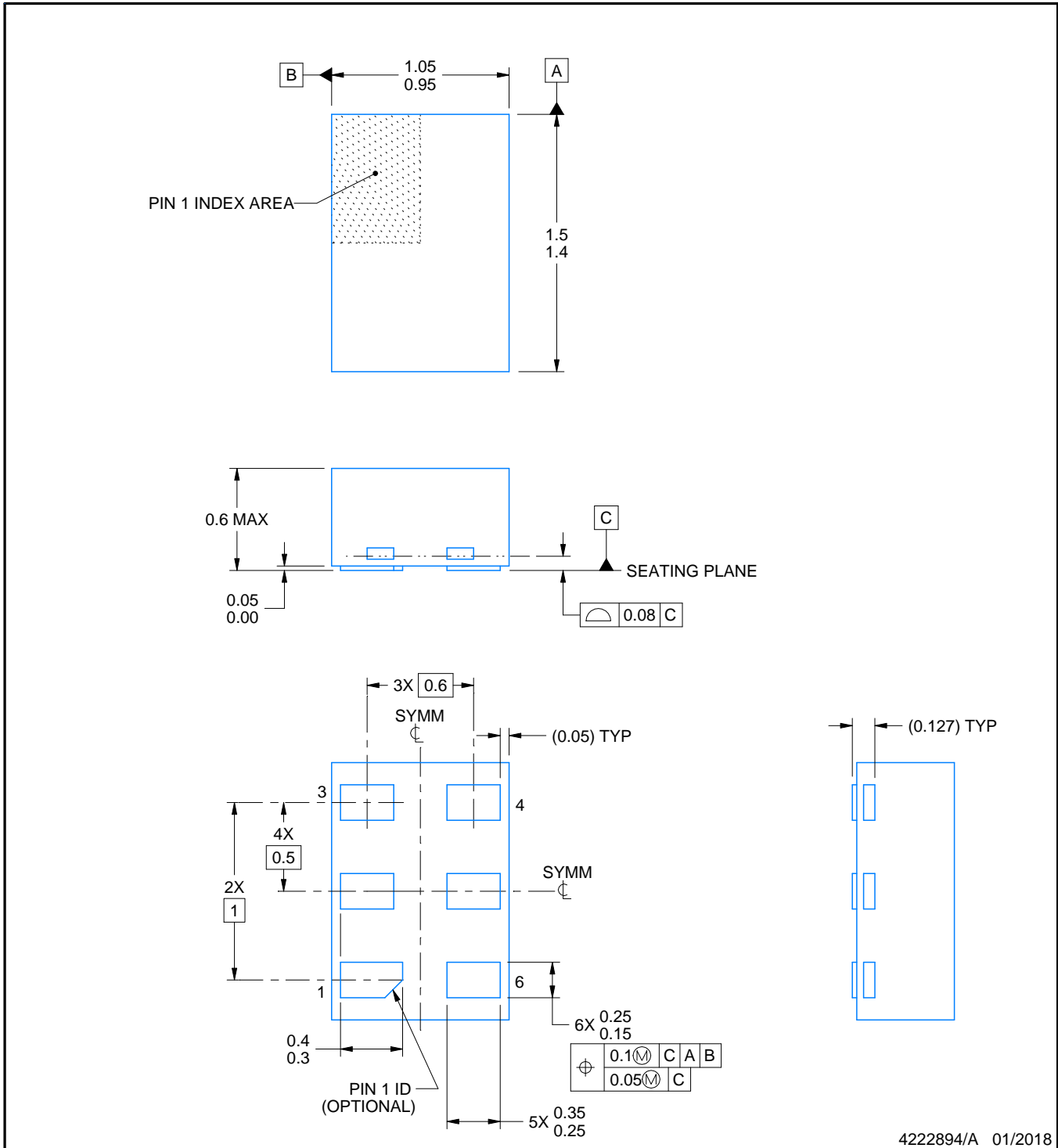

NOTES:

1. All linear dimensions are in millimeters. Any dimensions in parenthesis are for reference only. Dimensioning and tolerancing per ASME Y14.5M.
2. This drawing is subject to change without notice.

# EXAMPLE BOARD LAYOUT

DRY0006A

USON - 0.6 mm max height

PLASTIC SMALL OUTLINE - NO LEAD



LAND PATTERN EXAMPLE  
1:1 RATIO WITH PKG SOLDER PADS  
EXPOSED METAL SHOWN  
SCALE:40X



SOLDER MASK DETAILS

4222894/A 01/2018

NOTES: (continued)

3. For more information, see QFN/SON PCB application report in literature No. SLUA271 ([www.ti.com/lit/sluea271](http://www.ti.com/lit/sluea271)).

# EXAMPLE STENCIL DESIGN

DRY0006A

USON - 0.6 mm max height

PLASTIC SMALL OUTLINE - NO LEAD



SOLDER PASTE EXAMPLE  
BASED ON 0.075 - 0.1 mm THICK STENCIL  
SCALE:40X

4222894/A 01/2018

NOTES: (continued)

4. Laser cutting apertures with trapezoidal walls and rounded corners may offer better paste release. IPC-7525 may have alternate design recommendations.

## IMPORTANT NOTICE AND DISCLAIMER

TI PROVIDES TECHNICAL AND RELIABILITY DATA (INCLUDING DATASHEETS), DESIGN RESOURCES (INCLUDING REFERENCE DESIGNS), APPLICATION OR OTHER DESIGN ADVICE, WEB TOOLS, SAFETY INFORMATION, AND OTHER RESOURCES "AS IS" AND WITH ALL FAULTS, AND DISCLAIMS ALL WARRANTIES, EXPRESS AND IMPLIED, INCLUDING WITHOUT LIMITATION ANY IMPLIED WARRANTIES OF MERCHANTABILITY, FITNESS FOR A PARTICULAR PURPOSE OR NON-INFRINGEMENT OF THIRD PARTY INTELLECTUAL PROPERTY RIGHTS.

These resources are intended for skilled developers designing with TI products. You are solely responsible for (1) selecting the appropriate TI products for your application, (2) designing, validating and testing your application, and (3) ensuring your application meets applicable standards, and any other safety, security, or other requirements. These resources are subject to change without notice. TI grants you permission to use these resources only for development of an application that uses the TI products described in the resource. Other reproduction and display of these resources is prohibited. No license is granted to any other TI intellectual property right or to any third party intellectual property right. TI disclaims responsibility for, and you will fully indemnify TI and its representatives against, any claims, damages, costs, losses, and liabilities arising out of your use of these resources.

TI's products are provided subject to TI's Terms of Sale ([www.ti.com/legal/termsofsale.html](http://www.ti.com/legal/termsofsale.html)) or other applicable terms available either on [ti.com](http://ti.com) or provided in conjunction with such TI products. TI's provision of these resources does not expand or otherwise alter TI's applicable warranties or warranty disclaimers for TI products.

Mailing Address: Texas Instruments, Post Office Box 655303, Dallas, Texas 75265  
Copyright © 2019, Texas Instruments Incorporated

## Looking for pricing, stock, or lifecycle information?

Click below to explore more details on WIN SOURCE:

 [View TPS3898PDRYT on WIN SOURCE](#)

 [Texas Instruments](#) Information

## Optimize Your Supply Chain with WIN SOURCE Solutions

-  Global Sourcing Solution
-  Obsolete Management
-  Cost Control Management
-  Shortage Management
-  Alternative Solution
-  Excess Inventory Management