



**THE DATASHEET OF
TPS62751DSKT**



High Efficiency Step-Down Converter for USB Applications

Check for Samples : [TPS62750](#), [TPS62751](#)

FEATURES

- Efficiency > 90% at Nominal Operating Conditions
- Programmable Average Input Current Limits for USB Applications
 - 50mA to 300mA for Low Current Limit Range
 - 300mA to 1.3A for High Current Limit Range
 - $\pm 10\%$ Current Accuracy
- Stable Output Voltage for Load Transients to Minimize Overshoot at Load Step Response
- Hot Plug and Reverse Current Protection
- Automatic PFM/PWM Mode transition (TPS62750)
- Forced PWM for Noise Sensitive Applications (TPS62751)
- V_{IN} Range From 2.9V to 6V
- Adjustable V_{OUT} From 0.8V to $0.85 \times V_{IN}$
- Softstart for Inrush Current Prevention
- 2.25 MHz Fixed Frequency Operation
- Short Circuit and Thermal Shutdown Protection
- Available in a 2.5 x 2.5 10 pin SON Package

APPLICATIONS

- USB Wireless Modems
- Portable USB peripherals
- Handheld Computers

DESCRIPTION

The TPS6275x device is a highly efficient synchronous step down dc-dc converter optimized for USB powered portable applications. It can provide up to 1300mA average input current and is ideal for applications connected to a USB host.

With an input voltage range of 2.9 V to 6.0V, the device supports batteries with extended voltage range and is ideal for powering USB applications where USB compliance is required.

The TPS62750 operates at 2.25-MHz fixed switching frequency and enters Power Save Mode operation at light load currents to maintain high efficiency over the entire load current range. The TPS62751 operates in Forced PWM mode allowing use in applications that are noise sensitive. An output discharge allows the load to discharge in shutdown.

The 10% accurate average input current limit can be programmed with an external resistor, allowing use in applications such as USB, where the current drawn from the bus must be limited to 500mA.

The TPS6275x allows the use of small inductors and capacitors to achieve a small solution size. The TPS6275x is available in a 2,5mm x 2,5mm 10-pin SON package.

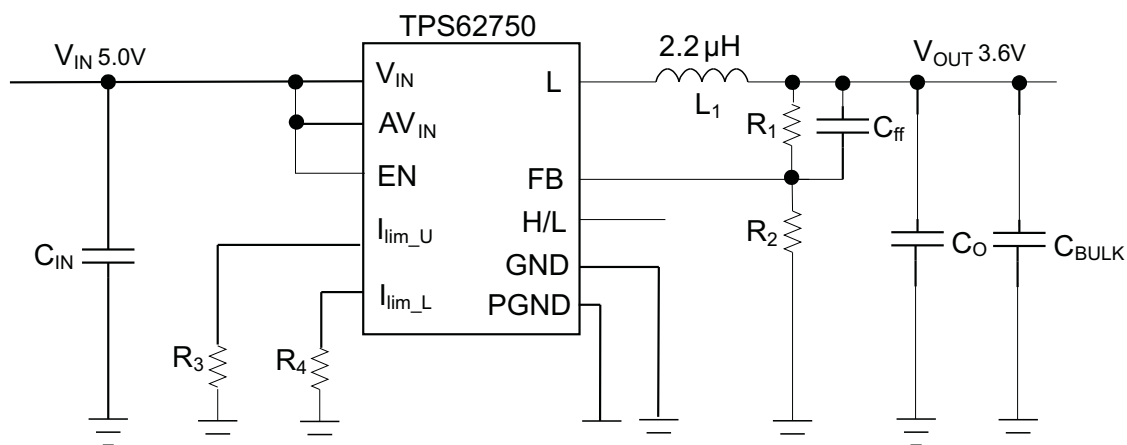

Please be aware that an important notice concerning availability, standard warranty, and use in critical applications of Texas Instruments semiconductor products and disclaimers thereto appears at the end of this data sheet.

TPS62750, TPS62751

SLVS955A – JULY 2009 – REVISED SEPTEMBER 2009

www.ti.com

This integrated circuit can be damaged by ESD. Texas Instruments recommends that all integrated circuits be handled with appropriate precautions. Failure to observe proper handling and installation procedures can cause damage.

ESD damage can range from subtle performance degradation to complete device failure. Precision integrated circuits may be more susceptible to damage because very small parametric changes could cause the device not to meet its published specifications.

Table 1. ORDERING INFORMATION⁽¹⁾

T _A	PART NUMBER ⁽²⁾	OUTPUT VOLTAGE ⁽³⁾	PACKAGE	PACKAGE DESIGNATOR	ORDERING	PACKAGE MARKING
-40°C to 85°C	TPS62750	Adjustable	SON 2.5x2.5 -10	DSK	TPS62750DSK	NXJ
	TPS62751				TPS62751DSK	DAL

- (1) For the most current package and ordering information, see the Package Option Addendum at the end of this document, or see the TI website at www.ti.com
- (2) The DSK (SON-10) package is available in tape on reel. Add R suffix to order quantities of 3000 parts per reel.
- (3) Contact TI for other fixed output voltage options

ABSOLUTE MAXIMUM RATINGS

 Over operating free-air temperature range (unless otherwise noted)⁽¹⁾

	VALUE	UNIT
Input voltage range V _{IN} , AV _{IN} ⁽²⁾	-0.3 to 7.0	V
Voltage range at EN, H/L, FB	-0.3 to V _{IN} +0.3, ≤7.0	V
Voltage on L, I _{Lim_U} , I _{Lim_L}	-0.3 to 7.0	V
Peak output current	Internally limited	A
ESD rating ⁽³⁾	HBM Human body model	4
	CDM Charge device model	1.5
	Machine model	200
Maximum operating junction temperature, T _J	-40 to 125	°C
Storage temperature range, T _{stg}	-65 to 150	°C

- (1) Stresses beyond those listed under *absolute maximum ratings* may cause permanent damage to the device. These are stress ratings only and functional operation of the device at these or any other conditions beyond those indicated under *recommended operating conditions* is not implied. Exposure to absolute-maximum-rated conditions for extended periods may affect device reliability.
- (2) All voltage values are with respect to network ground terminal.
- (3) The human body model is a 100pF capacitor discharged through a 1.5 kΩ resistor into each pin. The machine model is a 200pF capacitor discharged directly into each pin.

DISSIPATION RATINGS^{(1) (2)}

PACKAGE	THERMAL RESISTANCE R _{θJA}	THERMAL RESISTANCE R _{θJP}	THERMAL RESISTANCE R _{θJC}	POWER RATING FOR T _A ≤ 25°C	DERATING FACTOR ABOVE T _A = 25°C
DSK	60.6°C/W	6.3°C/W	40°C/W	1650mW	17mW/°C

- (1) Maximum power dissipation is a function of T_{J(max)}, θ_{JA} and T_A. The maximum allowable power dissipation at any allowable ambient temperature is P_D = [T_{J(max)} - T_A]/θ_{JA}
- (2) This thermal data is measured with a high-K board (4 layer board according to JESD51-7 JEDEC standard).

RECOMMENDED OPERATING CONDITIONS

	MIN	NOM	MAX	UNIT
Supply Voltage V _{IN}	2.9		6	V
Output voltage range for adjustable voltage	0.8		0.85 × V _{IN}	V
Operating ambient temperature, T _A	-40		85	°C
Operating virtual junction temperature, T _J	-40		125	°C

ELECTRICAL CHARACTERISTICS

Over full operating ambient temperature range, typical values are at $T_A = 25^\circ\text{C}$. Unless otherwise noted, specifications apply for condition $V_{IN} = EN = 5.0\text{V}$. External components $C_{IN} = 10\mu\text{F}$ 0603, $C_O = 10\mu\text{F}$ 0603, $C_{BULK} = 1.5\text{mF}$, $L = 2.2\mu\text{H}$, refer to parameter measurement information.

PARAMETER		TEST CONDITIONS	MIN	TYP	MAX	UNIT
SUPPLY						
V_{IN}	Input Voltage Range		2.9		6.0	V
I_Q	Operating Quiescent Current	$I_{OUT} = 0\text{ mA}$, device not switching (TPS62750) ⁽¹⁾		745	960	μA
		$I_{OUT} = 0\text{ mA}$, device not switching (TPS62751) ⁽¹⁾			30	mA
I_{SD}	Shutdown Current	EN = GND		0.2	3.0	μA
V_{UVLO}	Undervoltage Lockout Threshold	Falling	2.4			V
		Rising			2.9	V
ENABLE, H/L						
V_{IH}	High Level Input Voltage	$2.9\text{ V} \leq V_{IN} \leq 6.0\text{ V}$	1.0			V
V_{IL}	Low Level Input Voltage	$2.9\text{ V} \leq V_{IN} \leq 6.0\text{ V}$			0.4	V
I_{IN}	Input bias Current	Pin tied to GND or VIN		0.01	1.0	μA
POWER SWITCH						
$R_{DS(ON)}$	High side MOSFET On-Resistance (H/L=HI)	$V_{IN} = 5.0\text{ V}$, $V_{GS} = 6.5\text{ V}$		130	290	m Ω
	High side MOSFET On-Resistance (H/L=LO)	$V_{IN} = 5.0\text{ V}$, $V_{GS} = 6.5\text{ V}$		282	550	m Ω
	Low Side MOSFET On-Resistance	$V_{IN} = V_{GS} = 5.0\text{ V}$		58	125	m Ω
I_{LIMF}	Forward Current Limit High-Side and Low side	$V_{IN} = V_{GS} = 5.0\text{ V}$	1200	1500	1800	mA
$I_{IN(MAX)}$	Programmable Input current Range	I_{LIM_U} selected, H/L = High		300	1300	mA
		I_{LIM_L} selected, H/L = Low		50	300	
		I_{LIM_U} selected, Current limit accuracy		-10		10
T_{SD}	Thermal shutdown	Increasing junction temperature		150		$^\circ\text{C}$
	Thermal shutdown hysteresis	Decreasing junction temperature		20		$^\circ\text{C}$
OSCILLATOR						
f_{SW}	Oscillator Frequency	$2.9\text{ V} \leq V_{IN} \leq 6.0\text{ V}$	2.0	2.25	2.5	MHz
OUTPUT						
V_{OUT}	Adjustable Output Voltage Range		0.8		$0.85 \times V_{IN}$	V
V_{ref}	Reference Voltage			600		mV
$V_{FB(PWM)}$	Feedback Voltage	PWM operation, $2.9\text{ V} \leq V_{IN} \leq 6.0\text{ V}$ ⁽²⁾	-1.5%		1.5%	
$R_{(DIS_CH)}$	Internal discharge resistor	Activated with EN = GND	85	235	300	Ω

(1) In PFM mode, the internal reference voltage is set to typ. $1.01 \times V_{ref}$. See the parameter measurement information.

DEVICE INFORMATION

PIN ASSIGNMENTS

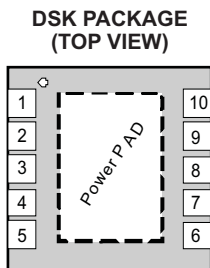

PIN FUNCTIONS

PIN		I/O	DESCRIPTION
NAME	NO.		
PGND	1		Power GND Pin for the N-MOSFET
L	2	OUT	This is the switch pin and is connected to the internal MOSFET switches. Connect the external inductor between this terminal and the output capacitor.
H/L	3	IN	H/L pin = high enables the upper current limit threshold set by R _{SET_H} . H/L pin = low enables the lower current limit threshold set by R _{SET_L} . This pin must be terminated.
EN	4	IN	This is the enable pin of the device. Pulling this pin to low forces the device into shutdown mode. Pulling this pin to high enables the device. This pin must be terminated.
FB	5	IN	Feedback Pin for the internal regulation loop. Connect the external resistor divider to this pin. In case of fixed output voltage option, connect this pin directly to the output capacitor
AGND	6		Analog GND Pin for the internal analog circuitry.
ISET_L	7	IN	Sets the lower average input current limit by external resistor.
ISET_U	8	IN	Sets the upper average input current limit by external resistor.
PVIN	9	IN	VIN power supply pin for the Output stage
AVIN	10	IN	VIN low noise analog supply for the internal analog circuitry. This pin must be connected to PVIN

FUNCTIONAL BLOCK DIAGRAM

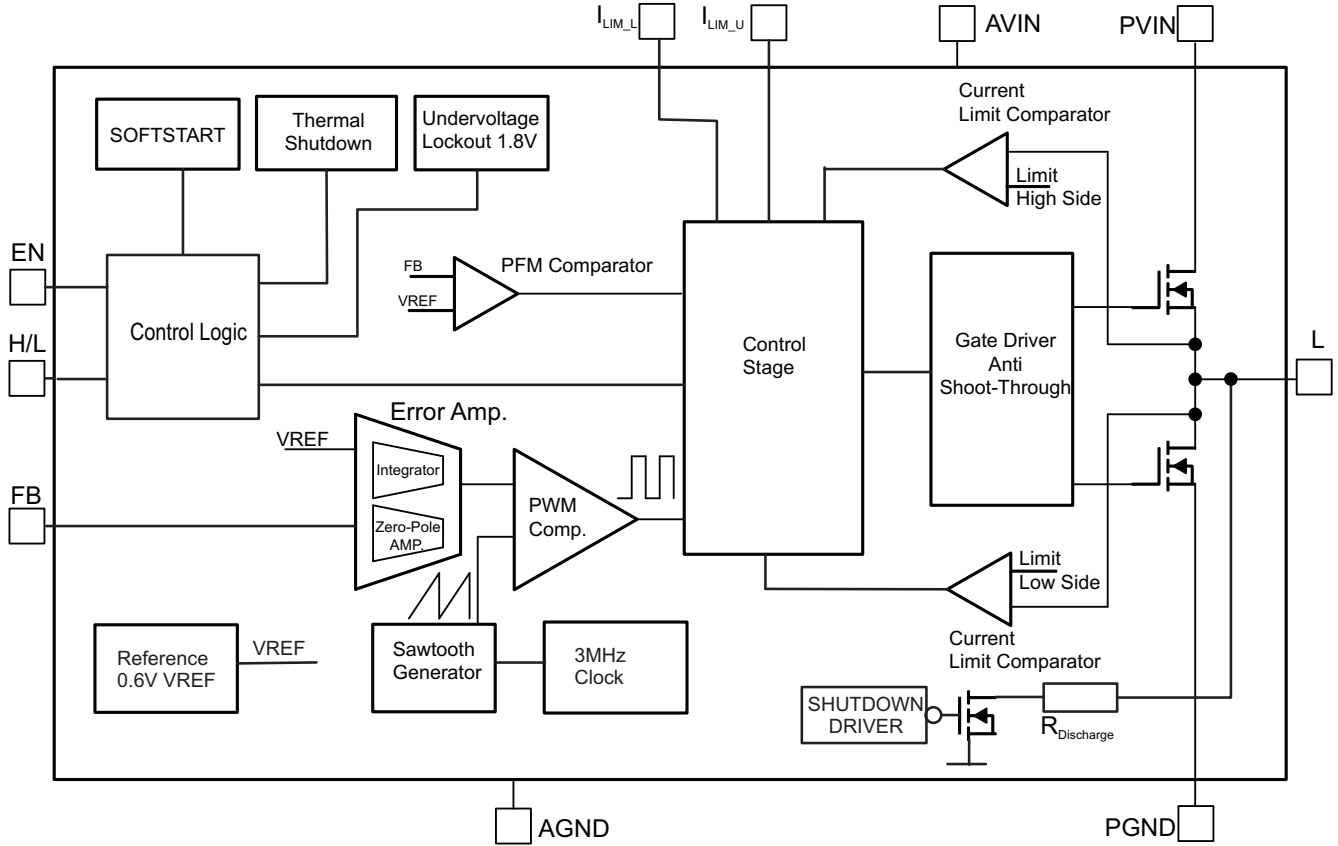

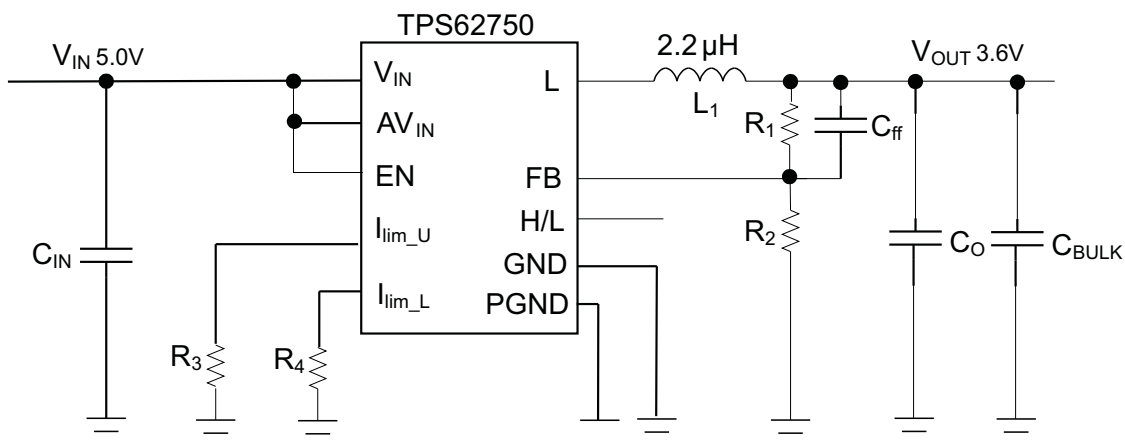
PARAMETER MEASUREMENT INFORMATION

Table 2. List of Components

COMPONENT REFERENCE	PART NUMBER	MANUFACTURER	VALUE
CIN	GRM188R60J106M	Murata	10 μ F
COUT	GRM188R60J106M	Murata	10 μ F
Cff	C1608C0G1H471J	TDK	470pF
CBULK	6TPG150M	Sanyo POSCAP	10 \times 150 μ F
	592D158X06R3X2T25H	Vishay	1.5mF
L1	LPS3015-222ML	Coilcraft	2.2 μ H
R1, R2	Depending on output voltage required. Equation 1 can be used to calculate the output voltage with different R1 and R2 values.		
R3, R4	Depending on the upper and lower current limits required. Equations 7 and 8 can be used for these calculations.		

TYPICAL CHARACTERISTICS

TABLE OF GRAPHS

		Figure
Maximum Output Current	vs Input voltage	Figure 1
Efficiency	vs Output Current, Vin = [4.0V; 4.5V; 5.0V; 5.5V], Vout = 3.6V, H/L = High	Figure 2
	vs Output Current, Vin = [4.0V; 4.5V; 5.0V; 5.5V], Vout = 3.6V, H/L = Low	Figure 3
	vs Output Current, Vin = [4.0V; 4.5V; 5.0V; 5.5V], Vout = 2.5V, H/L = High	Figure 4
	vs Output Current, Vin = [4.0V; 4.5V; 5.0V; 5.5V], Vout = 2.5V, H/L = Low	Figure 5
	vs Input Voltage, Vout = 3.6V, Iout = [200mA, 400mA, 500mA, 700mA, 1000mA]	Figure 6
Input Current	vs Output Current, Vout = 3.6V, Vin = [4.0V; 4.5V; 5.0V; 5.5V]	Figure 7
Output Voltage	vs Output Current, Vout = 3.6V, Vin = [4.5V; 5.0V; 5.5V], H/L = High	Figure 8
	vs Output Current, Vout = 3.6V, Vin = [4.5V; 5.0V; 5.5V], H/L = Low	Figure 9
	vs Input Voltage, Iload = 300mA, Vout = 3.6V H/L=high	Figure 10
	vs Input Voltage, Iload = 500mA, Vout = 3.6V H/L=high	Figure 11
	vs Input Voltage, Iload = 100μA, Vout = 3.6V H/L=low	Figure 12
	vs Input Voltage, Iload = 80mA, Vout = 3.6V H/L=low	Figure 13
Waveforms	Output Voltage Ripple, PFM Mode Iout = 50mA	Figure 14
	Output Voltage Ripple, PWM Mode Iout = 500mA	Figure 15
	Load Transient Vin = 5.0V, Vout = 3.6V, H/L = High, 50mA - 2A & 2A - 50mA, Pulse Load period = 4.6ms, duty cycle 12.5%	Figure 16
	Load Transient Vin = 5.0V, Vout = 3.6V, H/L = High, 50mA - 2A & 2A - 50mA, Pulse Load period = 4.6ms, duty cycle 25%	Figure 17
	Line Transient, Vin = 4.5V - 5.0V, Iout = 80mA, H/L = Low	Figure 18
	Line Transient, Vin = 4.5V - 5.0V, Iout = 200mA, H/L = Low	Figure 19
	Line Transient, Vin = 4.5V - 5.0V, Iout = 500mA, H/L = High	Figure 20
	Average Input current Limit vs R _{LIM_L}	Figure 21
	Average Input current Limit vs R _{LIM_U}	Figure 22
	Startup after Enable, Vin = 5.0V, Vout = 3.6V, Load = 80mA, H/L=Low	Figure 23
	Startup after Enable, Vin = 5.0V, Vout = 3.6V, Load = 500mA, H/L=High	Figure 24
Output Discharge, Vin = 5.0V, Vout = 3.6V, No Load	Figure 25	

TPS62750, TPS62751

SLVS955A – JULY 2009 – REVISED SEPTEMBER 2009

www.ti.com

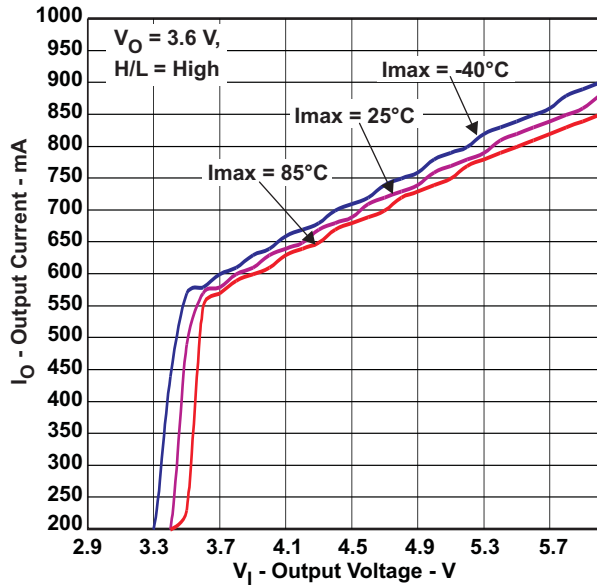

Figure 1. Maximum Output Current

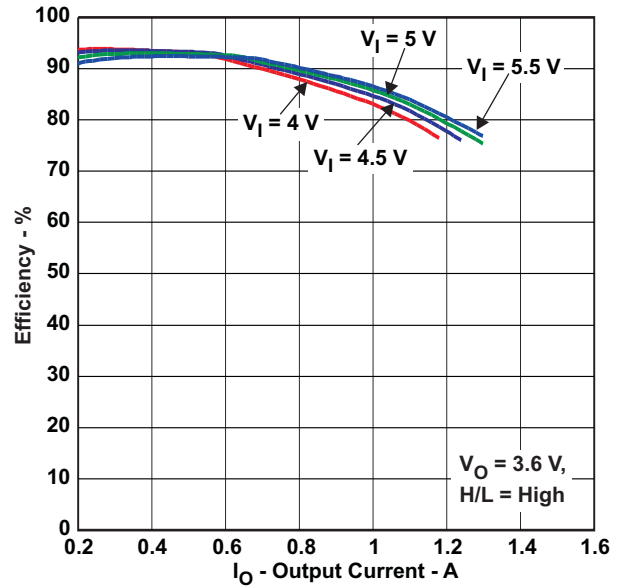

Figure 2. Efficiency vs Output Current

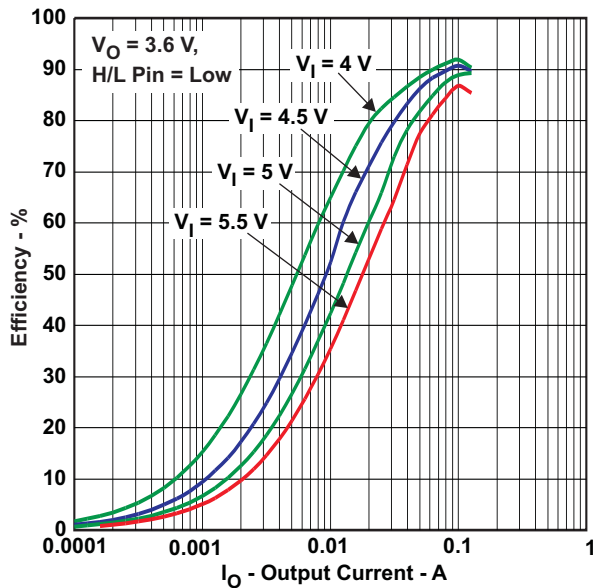

Figure 3. Efficiency vs Output Current

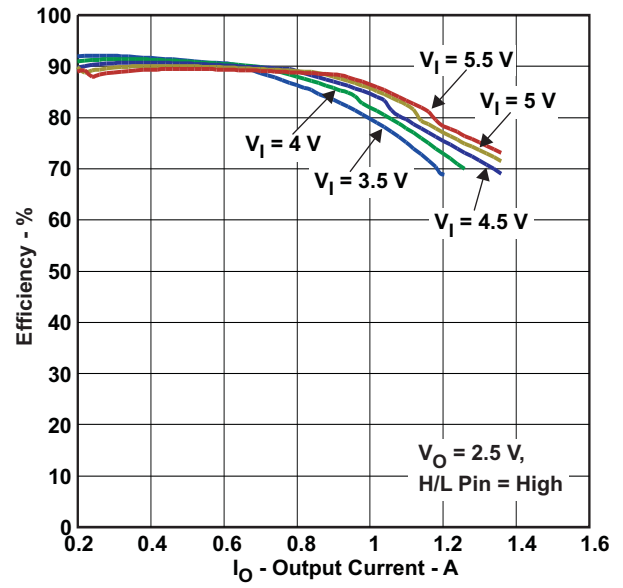

Figure 4. Efficiency vs Output Current

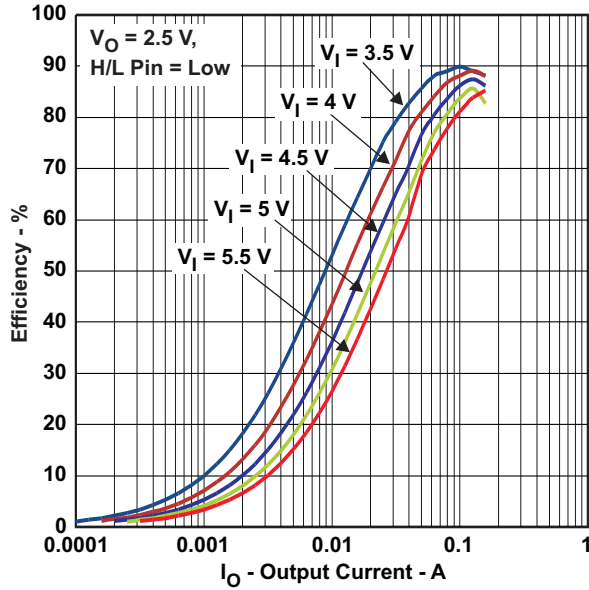

Figure 5. Efficiency vs Output Current

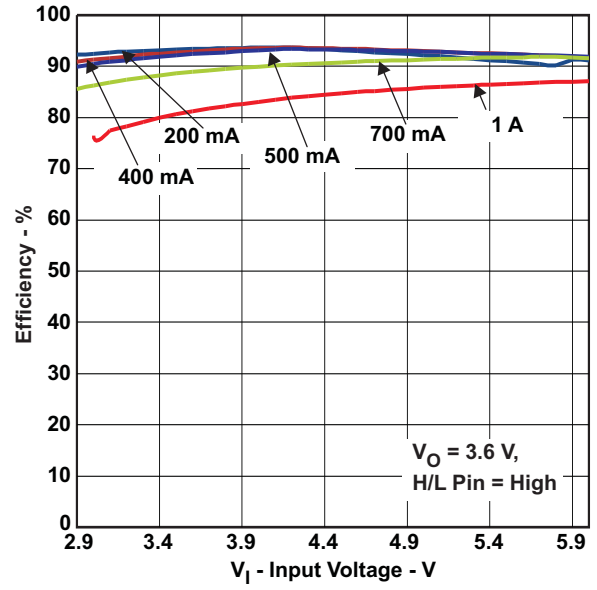

Figure 6. Efficiency vs Input Voltage

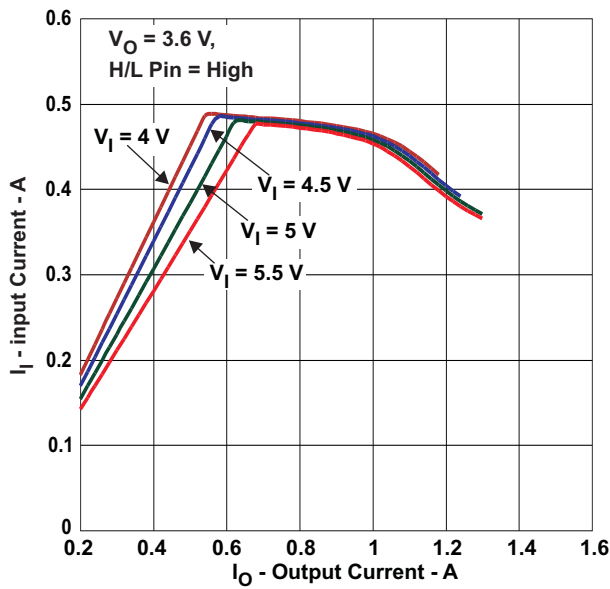

Figure 7. Input Current vs Output Current

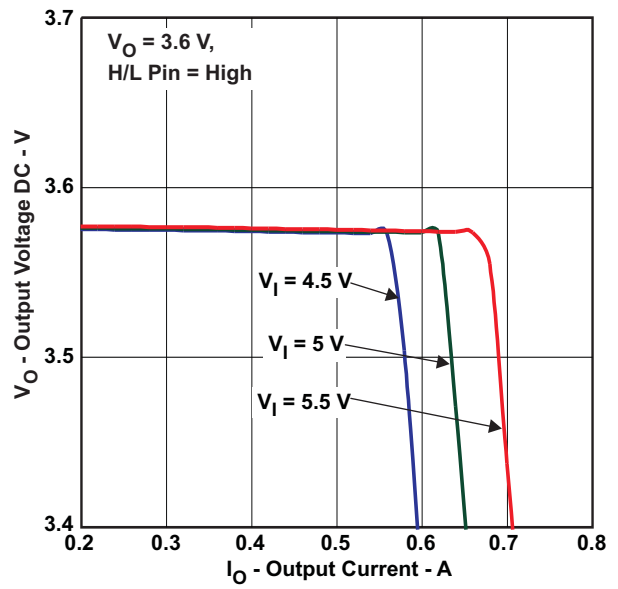

Figure 8. Output Voltage vs Output Current

TPS62750, TPS62751

SLVS955A – JULY 2009 – REVISED SEPTEMBER 2009

www.ti.com

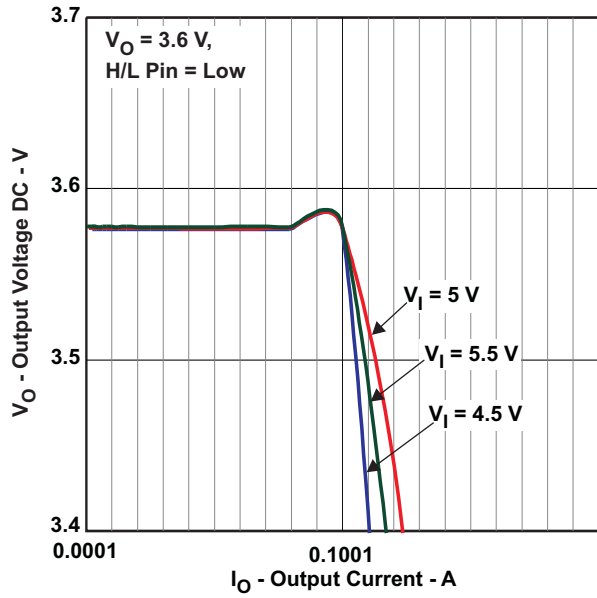

Figure 9. Output Voltage vs Output Current

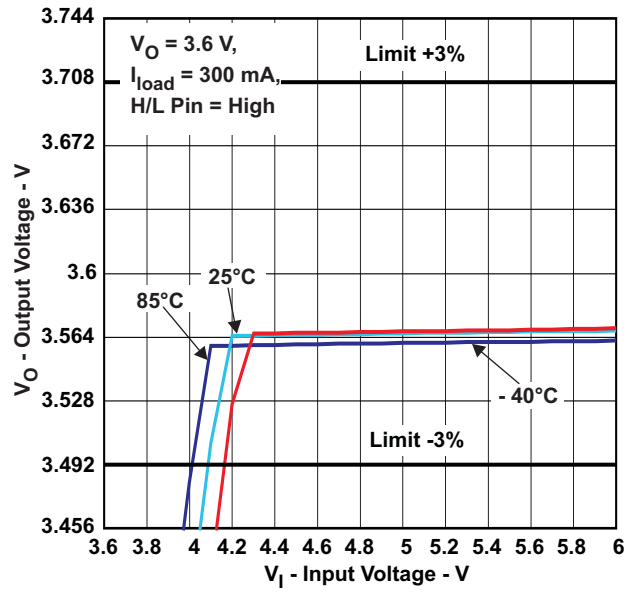

Figure 10. Output Voltage vs Input Voltage

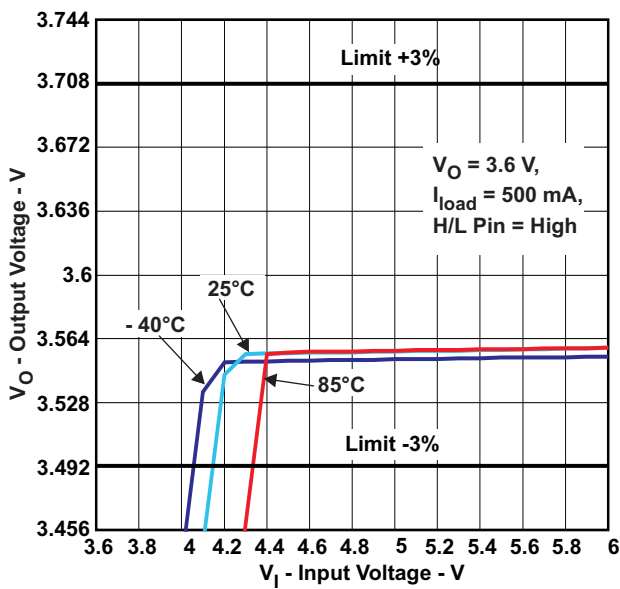

Figure 11. Output Voltage vs Input Voltage

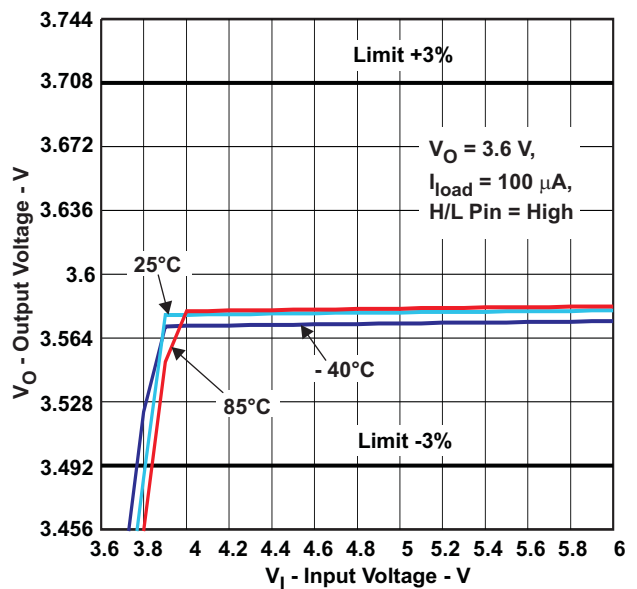

Figure 12. Output Voltage vs Input Voltage

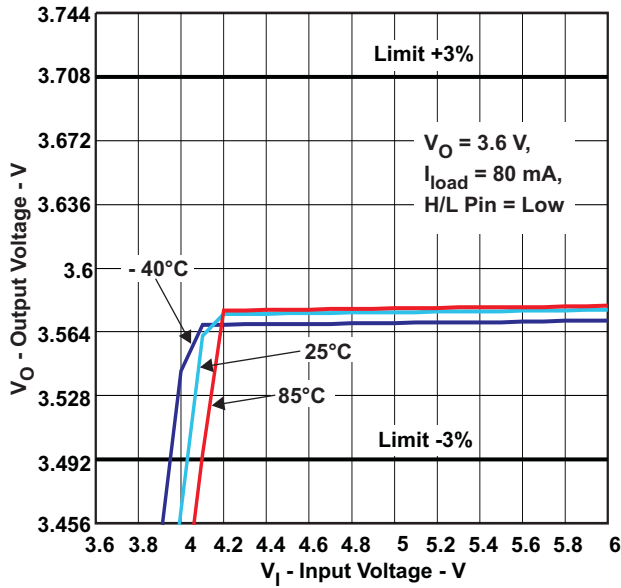

Figure 13. Output Voltage vs Input Voltage

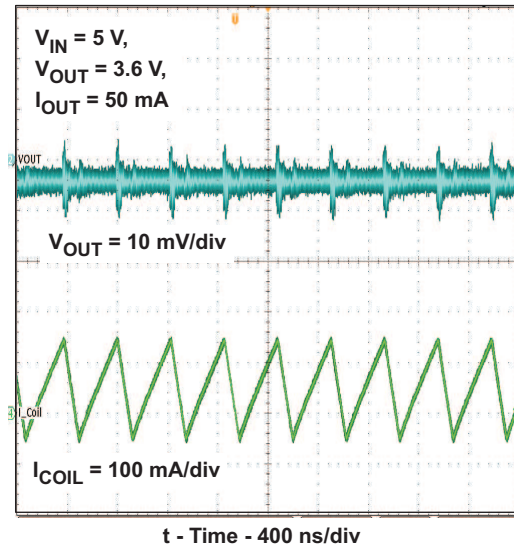

Figure 14. Output Voltage Ripple – PFM Mode

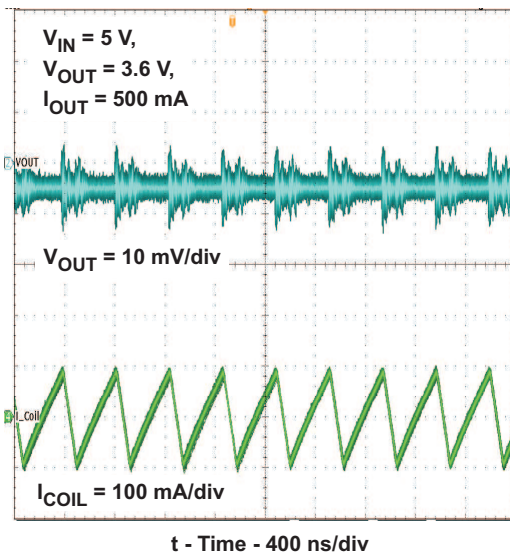

Figure 15. Output Voltage Ripple – PWM Mode

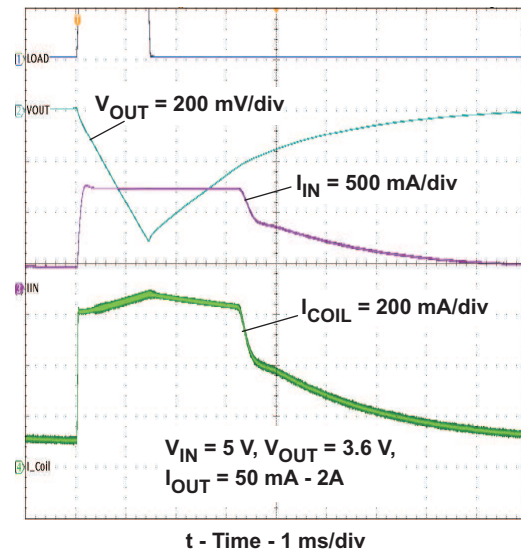

Figure 16. Load Transient

TPS62750, TPS62751

SLVS955A – JULY 2009 – REVISED SEPTEMBER 2009

www.ti.com

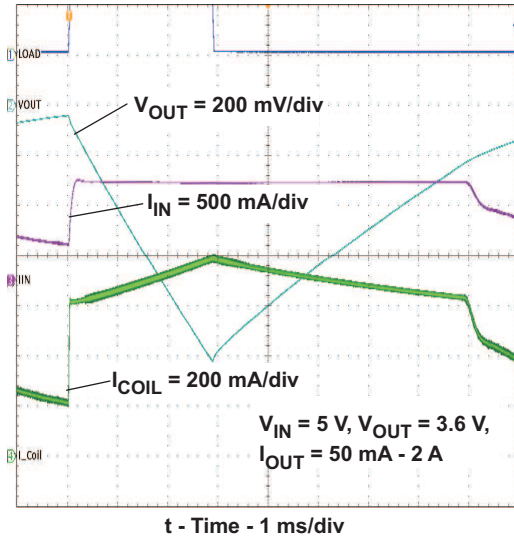

Figure 17. Load Transient

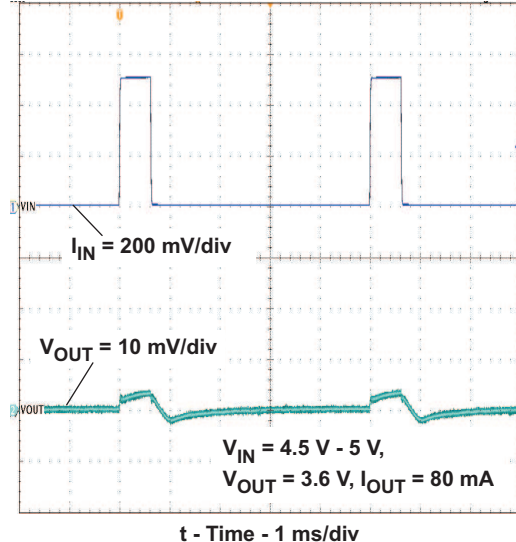

Figure 18. Line Transient

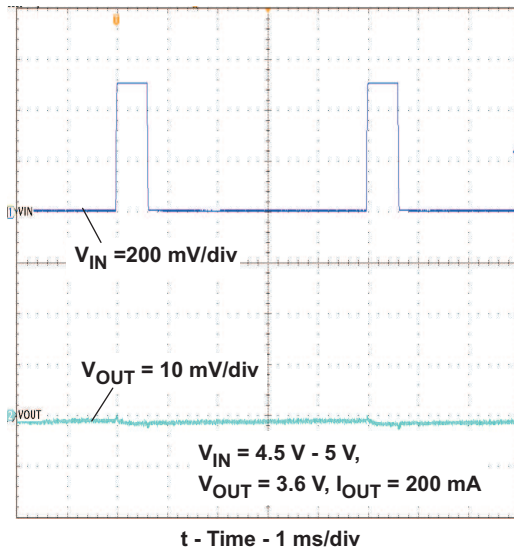

Figure 19. Line Transient

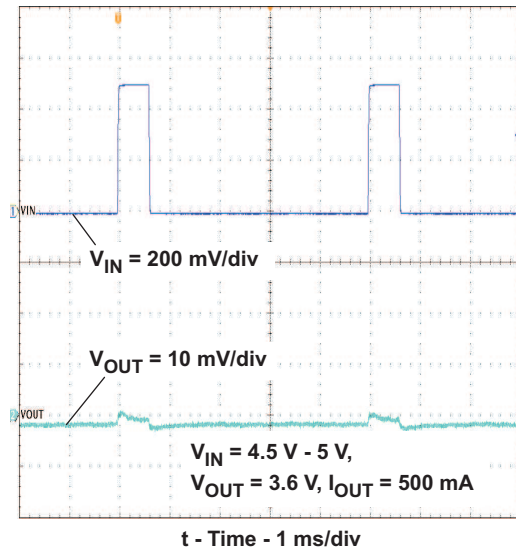

Figure 20. Line Transient

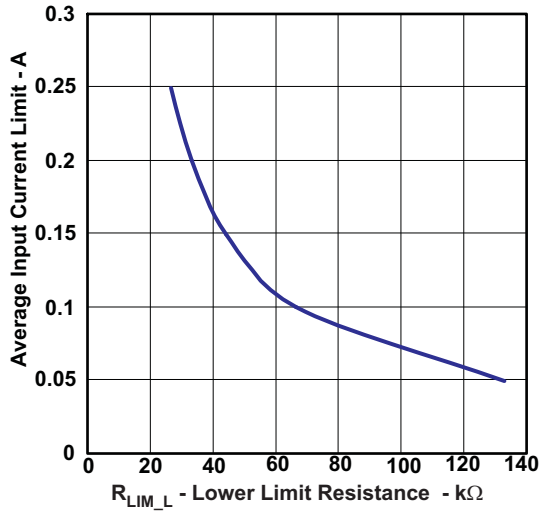

Figure 21. Average Input Current Limit

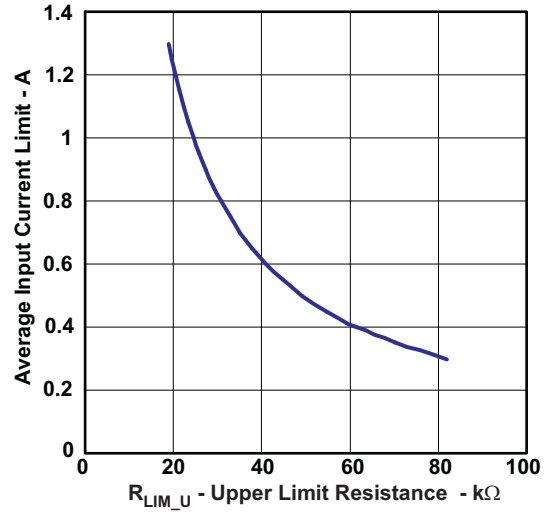

Figure 22. Average Input Current Limit

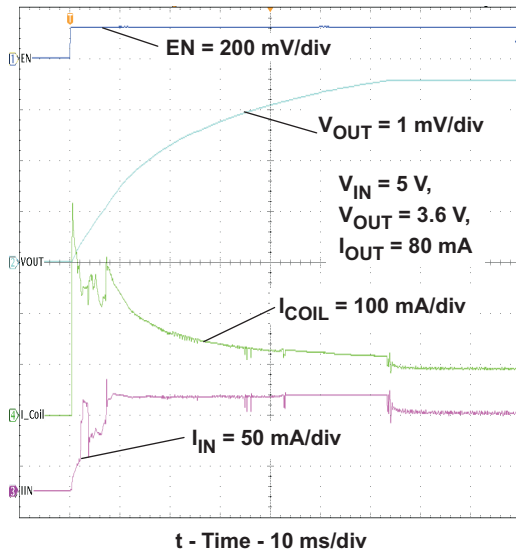

Figure 23. Startup After Enable

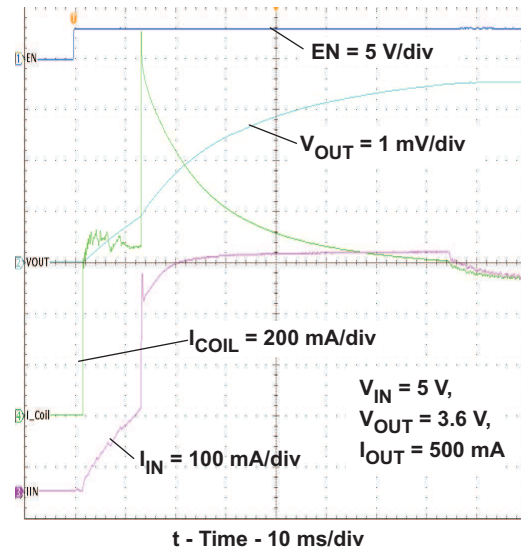

Figure 24. Startup After Enable

TPS62750, TPS62751

SLVS955A – JULY 2009 – REVISED SEPTEMBER 2009

www.ti.com

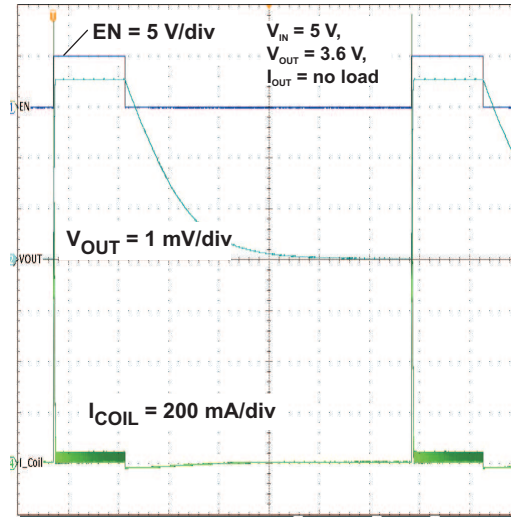

Figure 25. Output Discharge

DETAILED DESCRIPTION

OPERATION

The TPS6275x step down converter operates with typically 2.25MHz fixed frequency pulse width modulation (PWM) at moderate to heavy load currents. At light load currents the converter can automatically enter Power Save Mode and operates then in PFM (Pulse Frequency Mode) mode.

During PWM operation, the converter uses a unique fast response voltage mode controller scheme with input voltage feed-forward to achieve good line and load regulation allowing the use of small ceramic input and output capacitors. At the beginning of each clock cycle initiated by the clock signal, the High Side MOSFET switch is turned on. The current flows from the input capacitor via the High Side MOSFET switch through the inductor to the output capacitor and load. During this phase, the current ramps up until the PWM comparator trips and the control logic will turn off the switch.

The current limit comparator will also turn off the switch in case the current limit of the High Side MOSFET switch is exceeded. After a dead time preventing shoot through current, the Low Side MOSFET rectifier is turned on and the inductor current will ramp down. The current flows now from the inductor to the output capacitor and to the load. It returns back to the inductor through the Low Side MOSFET rectifier.

The next cycle will be initiated by the clock signal again turning off the Low Side MOSFET rectifier and turning on the on the High Side MOSFET switch.

POWER SAVE MODE

If the load current decreases, the converter will enter Power Save Mode operation automatically. During Power Save Mode the converter skips switching and operates with reduced frequency in PFM mode with a minimum quiescent current to maintain high efficiency.

The transition from PWM mode to PFM mode occurs once the inductor current in the Low Side MOSFET switch becomes zero, which indicates discontinuous conduction mode.

During the Power Save Mode the output voltage is monitored with a PFM comparator. As the output voltage falls below the PFM comparator threshold of V_{OUT} nominal +1%, the device starts a PFM current pulse. For this the High Side MOSFET switch will turn on and the inductor current ramps up. After the On-time expires the switch will be turned off and the Low Side MOSFET switch will be turned on until the inductor current becomes zero.

The converter effectively delivers a current to the output capacitor and the load. If the load is below the delivered current the output voltage will rise. If the output voltage is equal or higher than the PFM comparator threshold, the device stops switching and enters a sleep mode.

In case the output voltage is still below the PFM comparator threshold, further PFM current pulses will be generated until the PFM comparator threshold is reached. The converter starts switching again once the output voltage drops below the PFM comparator threshold.

With a fast single threshold comparator, the output voltage ripple during PFM mode operation can be kept very small. The PFM Pulse is timing controlled, which allows to modify the charge transferred to the output capacitor by the value of the inductor. The resulting PFM output voltage ripple depends in first order on the size of the output capacitor and the inductor value. Increasing output capacitor values and/or inductor values will minimize the output ripple.

The PFM mode is left and PWM mode entered in case the output current can not longer be supported in PFM mode.

ENABLE

The device is enabled setting EN pin to high. During the start up time $t_{start-up}$ the internal circuits are settled. Afterwards the device activates the soft start circuit. The EN input can be used to control power sequencing in a system with various DC/DC converters.

The EN pin can be connected to the output of another converter, to drive the EN pin high and getting a sequencing of supply rails. With EN = GND, the device enters shutdown mode. In this mode, all circuits are disabled. In fixed output voltage versions, the internal resistor divider network is disconnected from FB pin.

OUTPUT CAPACITOR DISCHARGE

With EN = GND, the device enters shutdown mode and all internal circuits are disabled. The SW pin is connected to PGND via an internal resistor (typically 235Ω) to discharge the output capacitor.

SOFT START

The TPS62750 has an internal soft start circuit that controls the ramp up of the output voltage. The output voltage ramps up from 5% to 95% of its nominal value in a controlled manner. This limits the inrush of current in the converter during start-up and prevents possible voltage drops when a battery or high impedance power source is used.

During soft start, the target average input current limit is reduced to 1/3 of its nominal value (I_{LIM_L} or I_{LIM_U}) until the output voltage reaches 1/3 of its nominal value. Once the output voltage trips this threshold, the device operates with its set target average input current limit.

The Soft-Start circuit is enabled after the start-up time $t_{start-up}$ has expired.

HOT-PLUG PROTECTION

In many applications it may be necessary to remove modules or pc boards while the main unit is still operating. These are considered hot-plug applications. Such implementations require the control of current surges seen by the main power supply and the card being inserted. The most effective way to control these surges is to limit and slowly ramp the current and voltage being applied to the card, similar to the way in which a power supply normally turns on.

Due to the controlled rise times and fall times and input over-voltage clamping of the TPS62750, these devices can be used to provide a softer start-up to devices being hot-plugged into a powered system. The UVLO feature of the TPS62750 also ensures that the switch is off after the card has been removed, and that the switch is off during the next insertion. The UVLO feature insures a soft start with a controlled rise time for every insertion of the card or module.

REVERSE CURRENT PROTECTION

The USB specification does not allow an output device to source current back into the USB port. However, the TPS62750 is designed to safely power non-compliant devices. When disabled, each output is switched to a high-impedance state, blocking reverse current flow from the output back to the input.

SHORT-CIRCUIT PROTECTION

During normal operation the High Side and Low Side MOSFET switches are protected by its current limits I_{LIMF} . Once the High Side MOSFET switch reaches its current limit, it is turned off and the Low Side MOSFET switch is turned on. The High Side MOSFET switch can only turn on again, once the current in the Low Side MOSFET switch decreases below its current limit. The device is capable to provide peak inductor currents up to its internal current limit I_{LIMF} .

As soon as the output voltage falls below 1/3 of the nominal output voltage due to overload or short circuit condition, the converter current limit is reduced to 1/3 of the nominal value I_{LIMF} . Due to the short-circuit protection is enabled during start-up, the device does not deliver more than 1/3 of its nominal current limit I_{LIMF} until the output voltage exceeds 1/3 of the nominal output voltage. This needs to be considered when a load is connected to the output of the converter, which acts as a current sink.

THERMAL SHUTDOWN

As soon as the junction temperature, T_J , exceeds 150°C (typical) the device goes into thermal shutdown. In this mode, the High Side and Low Side MOSFETs are turned-off. The device continues its operation when the junction temperature falls below the thermal shutdown hysteresis.

APPLICATION INFORMATION

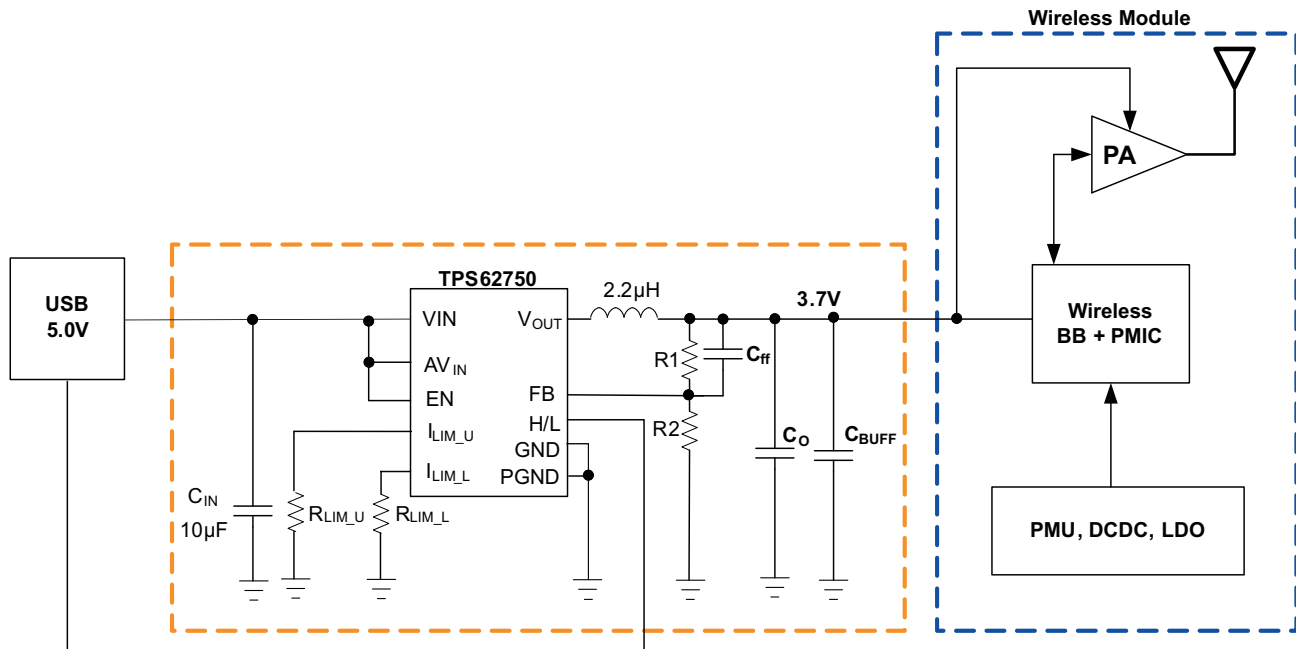

Figure 26. TPS62750DSK in a typical USB Datacard application

A growing variety of applications in notebooks, PCs and other mobile systems, TDMA data communication techniques, which require peak current (typically 2A) during the transmission of signals that can exceed the maximum current specified by the USB standard. Therefore, the application must be designed to limit the input power and draw on card-based storage for most of the energy requirement during a typical transmission cycle.

A typical GSM signal is transmitted over the carrier at a rate of 216 Hz (4.616ms pulse repetition interval). The transmission period is divided into eight time slots and depending on the power class being used, the duty cycle of this high current pulse can range anywhere between one-eighth of the cycle (577us) up to half of the transmission cycle (2.308ms).

The TPS62750 external current limit programming resistors can be easily used to adjust the required input current limit, thereby allowing the user to stay well within the specification requirement stipulated by USB. The TPS62750 is a high efficiency buck converter with programmable input average current limit that provides the needed flexibility when designing a GSM/GPRS power supply solution. The high efficiency of the converter maximizes the average output power without overloading the bus. A bulk output capacitor is used to supply the energy and maintain the output voltage during the high current pulses

OUTPUT VOLTAGE SETTING

$$V_{OUT} = V_{REF} \times \left(1 + \frac{R_1}{R_2} \right) \text{ with an internal reference voltage } V_{REF} \text{ typical } 0.6V \tag{1}$$

To minimize the current through the feedback divider network, we recommend that the R2 resistor value be 180k. The sum of R1 and R2 should not exceed ~1.5MΩ, to keep the network robust against noise.

An external feed forward capacitor C_{ff} is required for optimum load transient response. The value of C_{ff} should be a minimum of 470pF (see table below). Route the FB line away from noise sources, such as the inductor or the SW line.

OUTPUT CAPACITOR	FEEDFORWARD CAPACITOR
1 mF – 2.5 mF	470 pF
> 2.5 mF	1 nF

INDUCTOR SELECTION

The inductor value has a direct effect on the ripple current. The selected inductor has to be rated for its dc resistance and saturation current. The inductor ripple current (ΔI_L) decreases with higher inductance and increases with higher V_{IN} or V_{OUT} .

The inductor selection has also impact on the output voltage ripple in PFM mode. Higher inductor values will lead to lower output voltage ripple and higher PFM frequency, lower inductor values will lead to a higher output voltage ripple but lower PFM frequency.

Equation 2 calculates the maximum inductor current under static load conditions. The saturation current of the inductor should be rated higher than the maximum inductor current as calculated with **Equation 3**. This is recommended because during heavy load transient the inductor current will rise above the calculated value.

$$\Delta I_L = V_{out} \times \frac{1 - \frac{V_{out}}{V_{in}}}{L \times f} \quad (2)$$

$$I_{Lmax} = I_{outmax} + \frac{\Delta I_L}{2} \quad (3)$$

With:

f = Switching Frequency (2.25MHz typical)

L = Inductor Value

ΔI_L = Peak to Peak inductor ripple current

I_{Lmax} = Maximum Inductor current

A more conservative approach is to select the inductor current rating just for the maximum switch current of the corresponding converter. Accepting larger values of ripple current allows the use of low inductance values, but results in higher output voltage ripple, greater core losses, and lower output current capability. The device has been optimized to operate with inductance values between 1.0 μ H and 4.7 μ H. It is recommended that inductance values of at least 1.0 μ H is used, even if Equations 2 and 3 yield something lower.

The total losses of the coil have a strong impact on the efficiency of the DC/DC conversion and consist of both the losses in the dc resistance ($R_{(DC)}$) and the following frequency-dependent components:

- The losses in the core material (magnetic hysteresis loss, especially at high switching frequencies)
- Additional losses in the conductor from the skin effect (current displacement at high frequencies)
- Magnetic field losses of the neighboring windings (proximity effect)
- Radiation losses

Table 3. List of Inductors

MANUFACTURER	INDUCTOR TYPE	DIMENSIONS [mm]
Coilcraft	LPS3015-222ML	3.0 x 3.0 x 1.5
TOKO	1127AS-2R2M	3.5 x 3.7 x 1.8
Murata	LQH32PN1R0N0	3.2 x 2.5 x 1.7
TOKO	DB3015 Series	3.2 x 3.2 x 1.5

INPUT CAPACITOR SELECTION

Because of the nature of the buck converter having a pulsating input current, a low ESR input capacitor is required for best input voltage filtering and minimizing the interference with other circuits caused by high input voltage spikes. For most applications a 4.7 μ F to 10 μ F ceramic capacitor is recommended. The input capacitor can be increased without any limit for better input voltage filtering.

Take care when using only small ceramic input capacitors. When a ceramic capacitor is used at the input and the power is being supplied through long wires, such as from a wall adapter, a load step at the output or VIN step on the input can induce ringing at the VIN pin. This ringing can couple to the output and be mistaken as loop instability or could even damage the part by exceeding the maximum ratings.

OUTPUT CAPACITOR SELECTION

The TPS62750 has been specifically internally compensated to operate with large capacitance values. But to maintain loop stability of the device, it is recommended to use a small ceramic capacitor placed as close as possible to the V_{OUT} and GND pins of the IC in parallel with the large holdup capacitor. To get an estimate of the small ceramic recommended minimum output capacitance, Equation 4 can be used.

$$C_{min} = \frac{I_{OUT} \times (V_{OUT} - V_{IN})}{f \times \Delta V \times V_{OUT}} \quad (4)$$

Parameter f is the switching frequency and ΔV is the maximum allowed ripple.

With a chosen ripple voltage of 10 mV, a minimum effective capacitance of 2.7 μF is needed. The total ripple is larger due to the ESR of the output capacitor. This additional component of the ripple can be calculated using $\Delta V_{ESR} = I_{OUT} \times R_{ESR}$.

A capacitor with a value in the range of the calculated minimum should be used. This is required to maintain control loop stability. There are no additional requirements regarding minimum ESR. There is no upper limit for the output capacitance value. Larger capacitors cause lower output voltage ripple as well as lower output voltage drop during load transients.

Note that ceramic capacitors have a DC Bias effect, which will have a strong influence on the final effective capacitance needed. Therefore the right capacitor value has to be chosen very carefully. Package size and voltage rating in combination with material are responsible for differences between the rated capacitor value and the effective capacitance.

To calculate the value of the effective capacitance required to buffer a GSM transmission pulse, the following equations can be used:

$$\text{Capacitance} = \frac{I \times \Delta t}{\Delta V} \quad (5)$$

Assuming the DCDC supplies ~700mA, the rest of the energy to supply the GSM transmission pulse must come from the capacitor.

$$I_{CAP} = I_{GSM} - I_{DCDC}$$

$$I_{CAP} = 2A - 700mA = 1.3A$$

Assuming a GSM transmission pulse width of 1.154ms and allowing a maximum voltage drop on the output of 350mV, the effective capacitance required is:

$$\text{Capacitance} = \frac{1.3A \times 1.154ms}{350mV} = 4.2mF \quad (6)$$

Table 4. List of Capacitors

COMPONENT REFERENCE	PART NUMBER	MANUFACTURER	VALUE
C_O	GRM188R60J106M69D	Murata	10 μF
C_{BULK}	6TPG150M	Sanyo POSCAP	150 μF
	592D158X06R3X2T25H	Vishay	1.5mF
	592D228X06R3X2T22H	Vishay	2.2mF

AVERAGE INPUT CURRENT LIMIT

The average input current is set by selecting the correct external resistor value correlating to the required current limit. The current limit can be selected between a high current limit (I_{LIM_U}) and a lower limit (I_{LIM_L}) by toggling the H/L pin high or low. This has the added benefit that of allowing a device first plugged into the USB port to enumerate at 100mA before switching over to the high power mode (500mA). The equations below are a guideline for selecting the correct resistor value:

$$\text{Upper range: } R_{\text{LIM_U}} = \left(\frac{1.23}{I_{\text{LIM_U}}} \right) \times 20000 \quad (7)$$

$$\text{Lower range: } R_{\text{LIM_L}} = \left(\frac{1.23}{I_{\text{LIM_L}}} \right) \times 5400 \quad (8)$$

Examples of different input current limit values selectable are given in the table below:

AVERAGE INPUT CURRENT REQUIRED	RESISTOR VALUE
50 mA	132.8 K
100 mA	66.5 K
400 mA	61.5 K
500 mA	49.2 K
600 mA	41 K
700 mA	35.1 K

CHECKING LOOP STABILITY

The first step of circuit and stability evaluation is to look from a steady-state perspective at the following signals:

- Switching node, SW
- Inductor current, I_L
- Output ripple voltage, $V_{O(AC)}$

These are the basic signals that need to be measured when evaluating a switching converter. When the switching waveform shows large duty cycle jitter or the output voltage or inductor current shows oscillations, the regulation loop may be unstable. This is often a result of board layout and/or L-C combination.

As a next step in the evaluation of the regulation loop, the load transient response is tested. The time between the application of the load transient and the turn on of the P-channel MOSFET, the output capacitor must supply all of the current required by the load. V_O immediately shifts by an amount equal to $\Delta I_{(\text{LOAD})} \times \text{ESR}$, where ESR is the effective series resistance of C_O . $\Delta I_{(\text{LOAD})}$ begins to charge or discharge C_O generating a feedback error signal used by the regulator to return V_O to its steady-state value. The results are most easily interpreted when the device operates in PWM mode.

During this recovery time, V_O can be monitored for settling time, overshoot or ringing that helps judge the converter's stability. Without any ringing, the loop has usually more than 45° of phase margin. Because the damping factor of the circuitry is directly related to several resistive parameters (e.g., MOSFET $R_{\text{DS(on)}}$) that are temperature dependant, the loop stability analysis has to be done over the input voltage range, load current range, and temperature range.

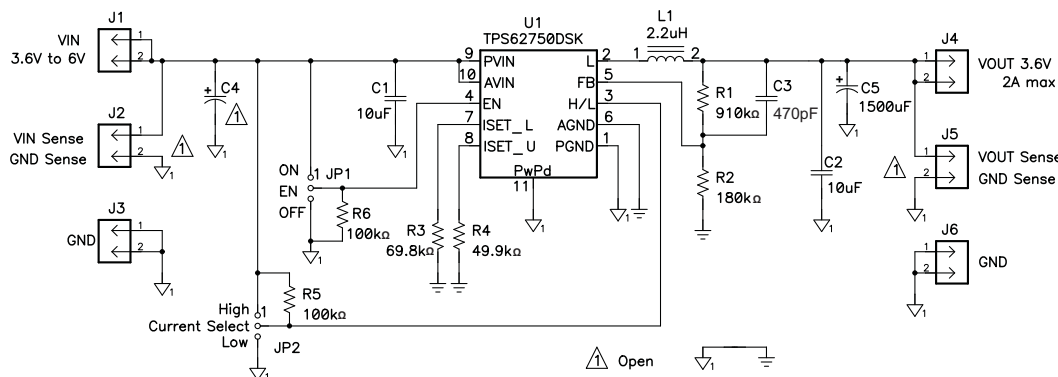

Figure 27. Checking Loop Stability

LAYOUT CONSIDERATIONS

As for all switching power supplies, the layout is an important step in the design. Proper function of the device demands careful attention to PCB layout. Care must be taken in board layout to get the specified performance. If the layout is not carefully done, the regulator could show poor line and/or load regulation, stability issues as well as EMI problems. It is critical to provide a low inductance, impedance ground path. Therefore, use wide and short traces for the main current paths. The input capacitor should be placed as close as possible to the IC pins as well as the inductor and output capacitor.

Connect the GND Pin of the device to the Power Pad of the PCB and use this Pad as a star point. Use a common Power GND node and a different node for the Signal GND to minimize the effects of ground noise. Connect these ground nodes together to the Power Pad (star point) underneath the IC. Keep the common path to the GND PIN, which returns the small signal components and the high current of the output capacitors as short as possible to avoid ground noise. The FB line should be connected right to the output capacitor and routed away from noisy components and traces (e.g., SW line).

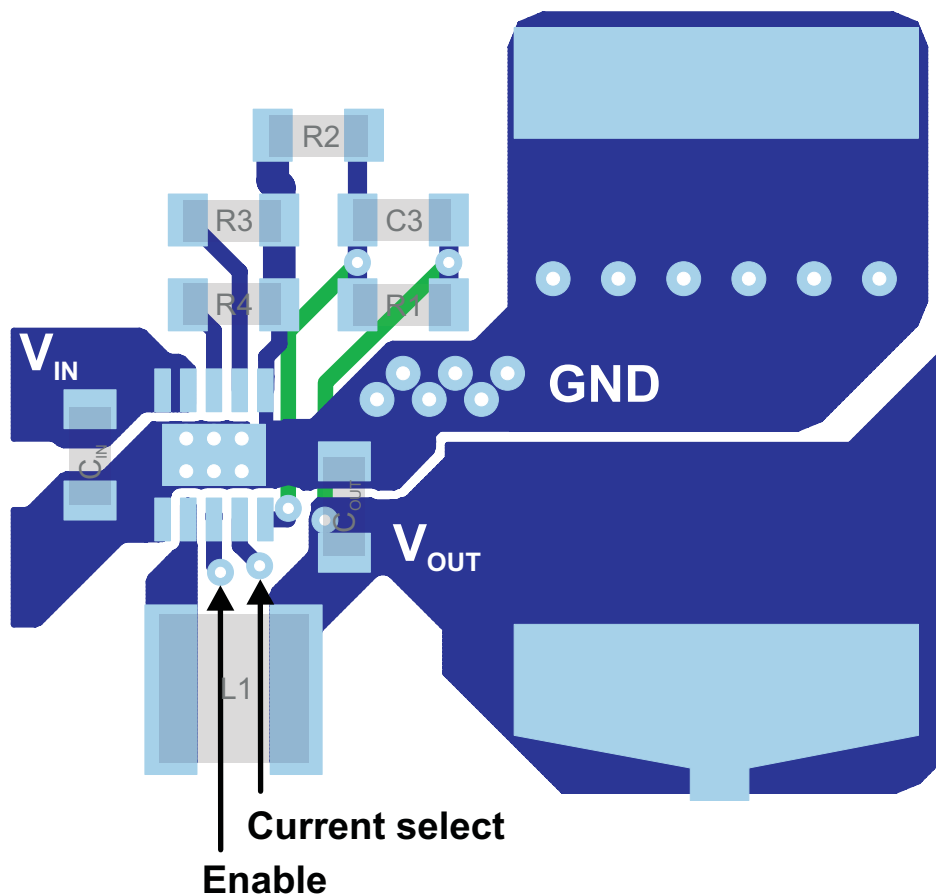

Figure 28. Suggested Layout

THERMAL INFORMATION

Implementation of integrated circuits in low-profile and fine-pitch surface-mount packages typically requires special attention to power dissipation. Many system-dependant issues such as thermal coupling, airflow, added heat sinks, and convection surfaces, and the presence of other heat-generating components, affect the power-dissipation limits of a given component. Three basic approaches for enhancing thermal performance are listed below:

- Improving the power dissipation capability of the PCB design
- Improving the thermal coupling of the component to the PCB
- Introducing airflow into the system

For more details on how to use the thermal parameters in the dissipation ratings table please check the Thermal Characteristics Application Note (SZZA017) and the IC Package Thermal Metrics Application Note (SPRA953).

Changes from Original (July 2009) to Revision A**Page**

• Added TPS62751 device	1
• Added TPS62751 specification	2
• Added TPS62751 specification	3

PACKAGING INFORMATION

Orderable Device	Status (1)	Package Type	Package Drawing	Pins	Package Qty	Eco Plan (2)	Lead/Ball Finish (6)	MSL Peak Temp (3)	Op Temp (°C)	Device Marking (4/5)	Samples
TPS62750DSKR	ACTIVE	SON	DSK	10	3000	Green (RoHS & no Sb/Br)	CU NIPDAU	Level-1-260C-UNLIM	-40 to 85	NXJ	Samples
TPS62750DSKT	ACTIVE	SON	DSK	10	250	Green (RoHS & no Sb/Br)	CU NIPDAU	Level-1-260C-UNLIM	-40 to 85	NXJ	Samples
TPS62751DSKR	ACTIVE	SON	DSK	10	3000	Green (RoHS & no Sb/Br)	CU NIPDAU	Level-1-260C-UNLIM	-40 to 85	DAL	Samples
TPS62751DSKT	ACTIVE	SON	DSK	10	250	Green (RoHS & no Sb/Br)	CU NIPDAU	Level-1-260C-UNLIM	-40 to 85	DAL	Samples

(1) The marketing status values are defined as follows:

ACTIVE: Product device recommended for new designs.

LIFEBUY: TI has announced that the device will be discontinued, and a lifetime-buy period is in effect.

NRND: Not recommended for new designs. Device is in production to support existing customers, but TI does not recommend using this part in a new design.

PREVIEW: Device has been announced but is not in production. Samples may or may not be available.

OBSOLETE: TI has discontinued the production of the device.

(2) **RoHS:** TI defines "RoHS" to mean semiconductor products that are compliant with the current EU RoHS requirements for all 10 RoHS substances, including the requirement that RoHS substance do not exceed 0.1% by weight in homogeneous materials. Where designed to be soldered at high temperatures, "RoHS" products are suitable for use in specified lead-free processes. TI may reference these types of products as "Pb-Free".

RoHS Exempt: TI defines "RoHS Exempt" to mean products that contain lead but are compliant with EU RoHS pursuant to a specific EU RoHS exemption.

Green: TI defines "Green" to mean the content of Chlorine (Cl) and Bromine (Br) based flame retardants meet JS709B low halogen requirements of <=1000ppm threshold. Antimony trioxide based flame retardants must also meet the <=1000ppm threshold requirement.

(3) MSL, Peak Temp. - The Moisture Sensitivity Level rating according to the JEDEC industry standard classifications, and peak solder temperature.

(4) There may be additional marking, which relates to the logo, the lot trace code information, or the environmental category on the device.

(5) Multiple Device Markings will be inside parentheses. Only one Device Marking contained in parentheses and separated by a "-" will appear on a device. If a line is indented then it is a continuation of the previous line and the two combined represent the entire Device Marking for that device.

(6) Lead/Ball Finish - Orderable Devices may have multiple material finish options. Finish options are separated by a vertical ruled line. Lead/Ball Finish values may wrap to two lines if the finish value exceeds the maximum column width.

Important Information and Disclaimer:The information provided on this page represents TI's knowledge and belief as of the date that it is provided. TI bases its knowledge and belief on information provided by third parties, and makes no representation or warranty as to the accuracy of such information. Efforts are underway to better integrate information from third parties. TI has taken and

continues to take reasonable steps to provide representative and accurate information but may not have conducted destructive testing or chemical analysis on incoming materials and chemicals. TI and TI suppliers consider certain information to be proprietary, and thus CAS numbers and other limited information may not be available for release.

In no event shall TI's liability arising out of such information exceed the total purchase price of the TI part(s) at issue in this document sold by TI to Customer on an annual basis.

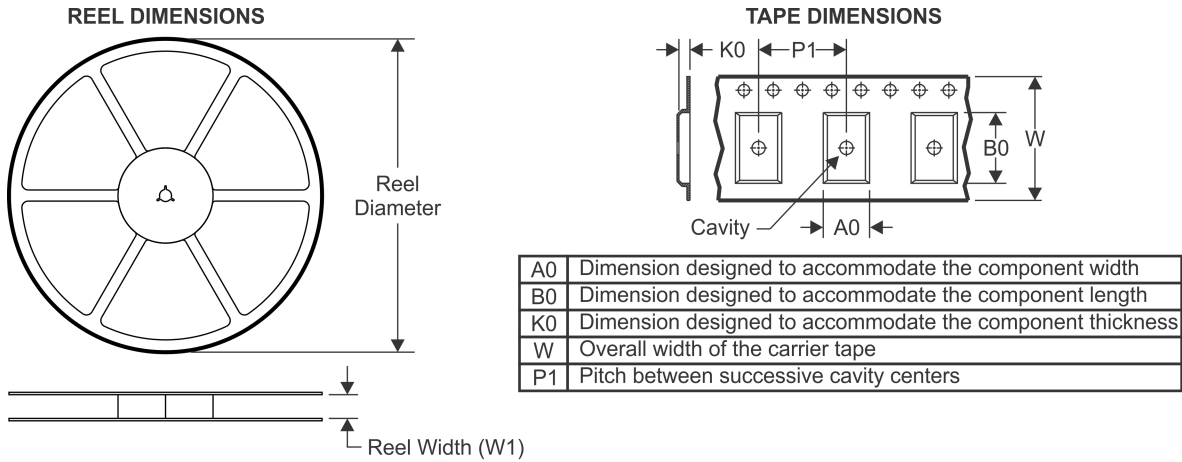
TAPE AND REEL INFORMATION

QUADRANT ASSIGNMENTS FOR PIN 1 ORIENTATION IN TAPE

*All dimensions are nominal

Device	Package Type	Package Drawing	Pins	SPQ	Reel Diameter (mm)	Reel Width W1 (mm)	A0 (mm)	B0 (mm)	K0 (mm)	P1 (mm)	W (mm)	Pin1 Quadrant
TPS62750DSKR	SON	DSK	10	3000	179.0	8.4	2.73	2.73	0.8	4.0	8.0	Q2
TPS62750DSKT	SON	DSK	10	250	179.0	8.4	2.73	2.73	0.8	4.0	8.0	Q2
TPS62751DSKR	SON	DSK	10	3000	179.0	8.4	2.73	2.73	0.8	4.0	8.0	Q2
TPS62751DSKT	SON	DSK	10	250	179.0	8.4	2.73	2.73	0.8	4.0	8.0	Q2

TAPE AND REEL BOX DIMENSIONS

*All dimensions are nominal

Device	Package Type	Package Drawing	Pins	SPQ	Length (mm)	Width (mm)	Height (mm)
TPS62750DSKR	SON	DSK	10	3000	203.0	203.0	35.0
TPS62750DSKT	SON	DSK	10	250	203.0	203.0	35.0
TPS62751DSKR	SON	DSK	10	3000	203.0	203.0	35.0
TPS62751DSKT	SON	DSK	10	250	203.0	203.0	35.0

DSK (S-PDSO-N10)

PLASTIC QUAD FLATPACK

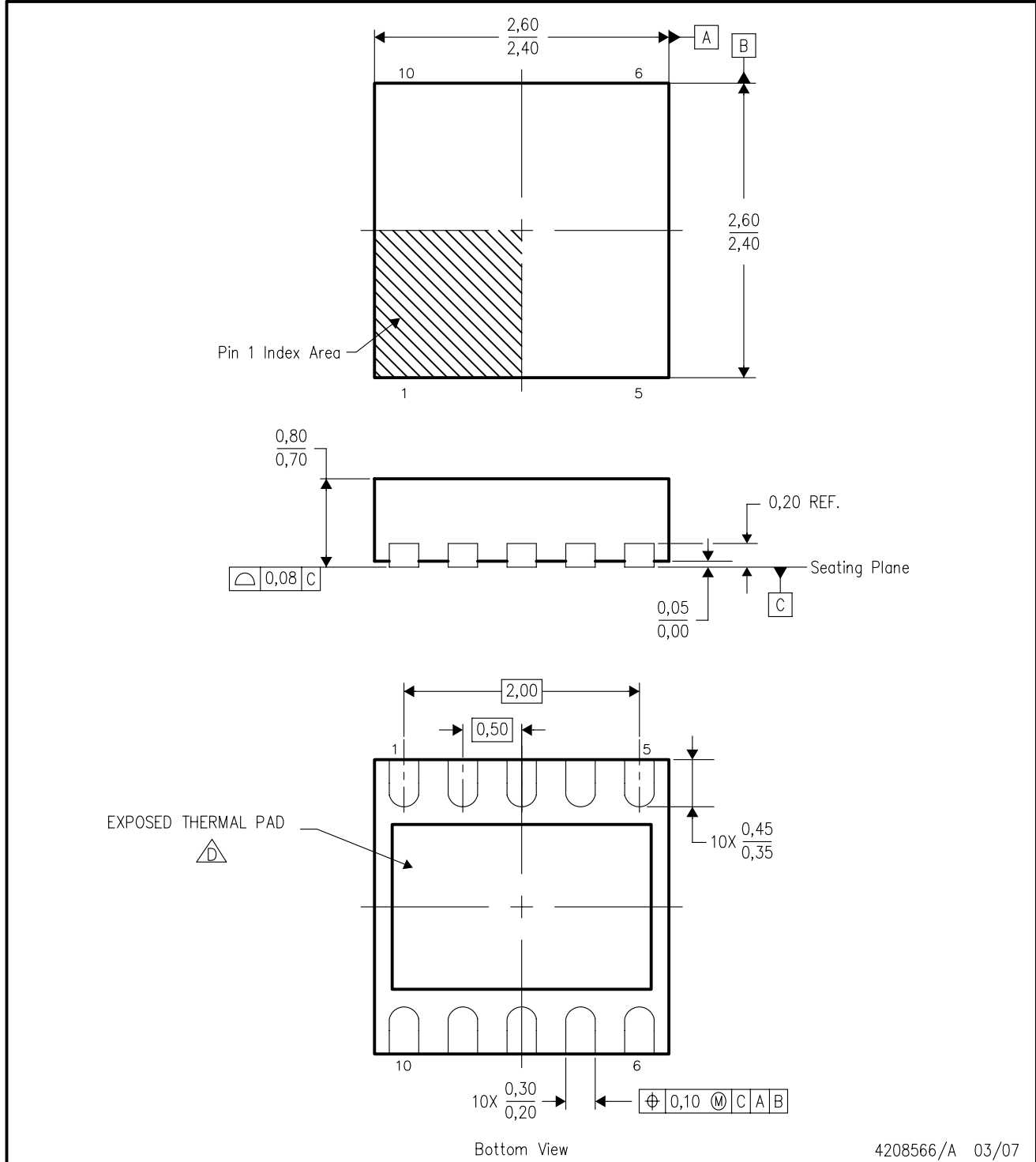

4208566/A 03/07

- NOTES:
- A. All linear dimensions are in millimeters. Dimensioning and tolerancing per ASME Y14.5M-1994.
 - B. This drawing is subject to change without notice.
 - C. Small Outline No-Lead (SON) package configuration.
 -  The package thermal pad must be soldered to the board for thermal and mechanical performance. See the Product Data Sheet for details regarding the exposed thermal pad dimensions.

THERMAL PAD MECHANICAL DATA

DSK (R-PWSON-N10)

PLASTIC SMALL OUTLINE NO-LEAD

THERMAL INFORMATION

This package incorporates an exposed thermal pad that is designed to be attached directly to an external heatsink. The thermal pad must be soldered directly to the printed circuit board (PCB). After soldering, the PCB can be used as a heatsink. In addition, through the use of thermal vias, the thermal pad can be attached directly to the appropriate copper plane shown in the electrical schematic for the device, or alternatively, can be attached to a special heatsink structure designed into the PCB. This design optimizes the heat transfer from the integrated circuit (IC).

For information on the Quad Flatpack No-Lead (QFN) package and its advantages, refer to Application Report, QFN/SON PCB Attachment, Texas Instruments Literature No. SLUA271. This document is available at www.ti.com.

The exposed thermal pad dimensions for this package are shown in the following illustration.

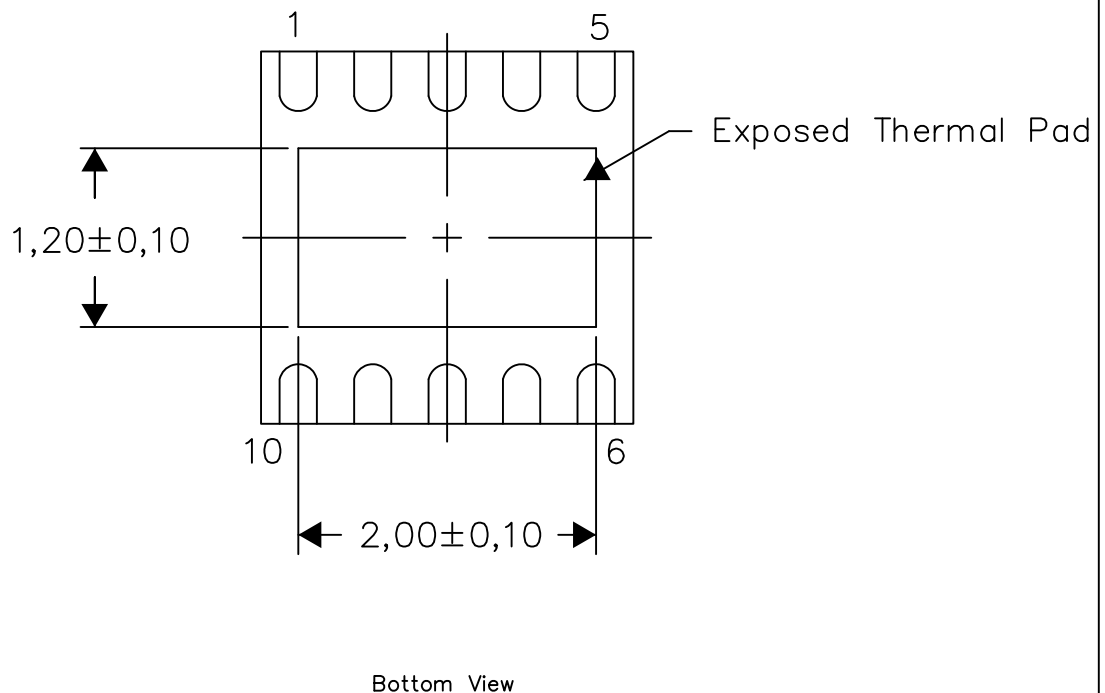

Exposed Thermal Pad Dimensions

4208579-2/E 12/12

NOTE: All linear dimensions are in millimeters

DSK (R-PWSON-N10)

PLASTIC SMALL OUTLINE NO-LEAD

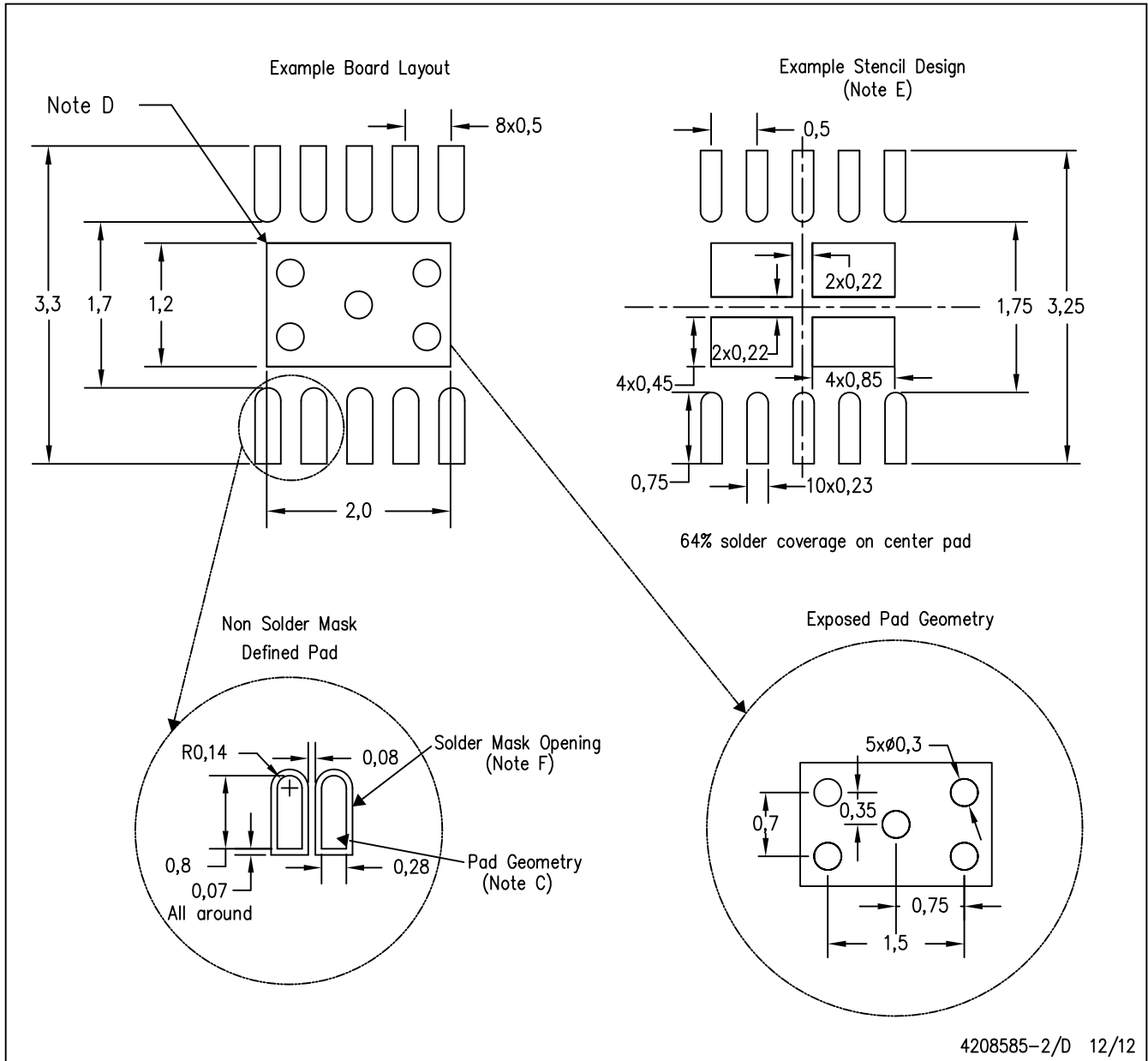

- NOTES:
- All linear dimensions are in millimeters.
 - This drawing is subject to change without notice.
 - Publication IPC-SM-782 is recommended for alternate designs.
 - This package is designed to be soldered to a thermal pad on the board. Refer to Application Note, Quad Flat-Pack Packages, Texas Instruments Literature No. SLUA271, and also the Product Data Sheets for specific thermal information, via requirements, and recommended board layout. These documents are available at www.ti.com <<http://www.ti.com>>.
 - Laser cutting apertures with trapezoidal walls and also rounding corners will offer better paste release. Customers should contact their board assembly site for stencil design recommendations. Refer to IPC 7525 for stencil design considerations.
 - Customers should contact their board fabrication site for minimum solder mask web tolerances between signal pads.

IMPORTANT NOTICE AND DISCLAIMER

TI PROVIDES TECHNICAL AND RELIABILITY DATA (INCLUDING DATASHEETS), DESIGN RESOURCES (INCLUDING REFERENCE DESIGNS), APPLICATION OR OTHER DESIGN ADVICE, WEB TOOLS, SAFETY INFORMATION, AND OTHER RESOURCES "AS IS" AND WITH ALL FAULTS, AND DISCLAIMS ALL WARRANTIES, EXPRESS AND IMPLIED, INCLUDING WITHOUT LIMITATION ANY IMPLIED WARRANTIES OF MERCHANTABILITY, FITNESS FOR A PARTICULAR PURPOSE OR NON-INFRINGEMENT OF THIRD PARTY INTELLECTUAL PROPERTY RIGHTS.

These resources are intended for skilled developers designing with TI products. You are solely responsible for (1) selecting the appropriate TI products for your application, (2) designing, validating and testing your application, and (3) ensuring your application meets applicable standards, and any other safety, security, or other requirements. These resources are subject to change without notice. TI grants you permission to use these resources only for development of an application that uses the TI products described in the resource. Other reproduction and display of these resources is prohibited. No license is granted to any other TI intellectual property right or to any third party intellectual property right. TI disclaims responsibility for, and you will fully indemnify TI and its representatives against, any claims, damages, costs, losses, and liabilities arising out of your use of these resources.

TI's products are provided subject to TI's Terms of Sale (www.ti.com/legal/termsofsale.html) or other applicable terms available either on ti.com or provided in conjunction with such TI products. TI's provision of these resources does not expand or otherwise alter TI's applicable warranties or warranty disclaimers for TI products.

Mailing Address: Texas Instruments, Post Office Box 655303, Dallas, Texas 75265
Copyright © 2019, Texas Instruments Incorporated

Looking for pricing, stock, or lifecycle information?

Click below to explore more details on WIN SOURCE:

 [View TPS62751DSKT on WIN SOURCE](#)

 [Texas Instruments](#) Information

Optimize Your Supply Chain with WIN SOURCE Solutions

-  Global Sourcing Solution
-  Obsolete Management
-  Cost Control Management
-  Shortage Management
-  Alternative Solution
-  Excess Inventory Management