



**THE DATASHEET OF  
TPS74012DGKT**



# 1.5-A, Low-Voltage LDO Regulator with Dual Input Voltages

## FEATURES

- **Small Consumption Current: 3 mA Maximum**
- **Input Voltage Range:**
  - $V_{IN}$ : 1.2 V to 6.0 V
  - $V_{BIAS}$ : 2.9 V to 6.0 V
- **Stable with Any Output Capacitance:  $\geq 2.2 \mu\text{F}$**
- **$\pm 1\%$  Initial Accuracy**
- **Maximum Dropout Voltage ( $V_{IN} - V_{OUT}$ ): 300 mV Over Temperature**
- **Adjustable Output Voltage: Down to 0.9 V**
- **Ultra-Fast Transient Response**
- **Excellent Line and Load Regulation**
- **Logic-Controlled Shutdown Option**
- **Thermal Shutdown and Current Limit Protection**
- **Power 8-Pin Mini Small-Outline Package (MSOP) and Jr S-PAK™ packages.**
- **Junction Temperature Range:  $-40^\circ\text{C}$  to  $+125^\circ\text{C}$**

## APPLICATIONS

- **Graphics Processors**
- **PC Add-In Cards**
- **Microprocessors**
- **Low-Voltage Digital ICs**
- **High-Efficiency Linear Power Supplies**
- **Switch-Mode Power-Supply Post Regulation**

## DESCRIPTION

The TPS740xx is a wide bandwidth, very low-dropout, 1.5-A voltage regulator ideal for powering microprocessors.

The TPS740xx uses a bias input supply to allow very low voltage of a main input supply. The main input supply operates from 1.2 V to 6.0 V and the bias input supply requires between 3.0 V to 6.0 V for proper operation. The TPS740xx offers adjustable output voltages down to 0.9 V.

The TPS740xx requires a minimum of output capacitance. A small 2.2- $\mu\text{F}$  ceramic capacitor is enough for its stability.

The TPS740xx is available in an 8-pin power MSOP package and a 5-pin Jr S-PAK. Its operating temperature range is  $-40^\circ\text{C}$  to  $+125^\circ\text{C}$ .

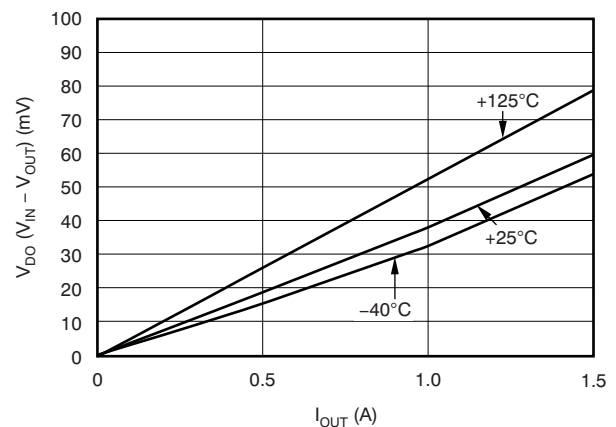

**Dropout Voltage**

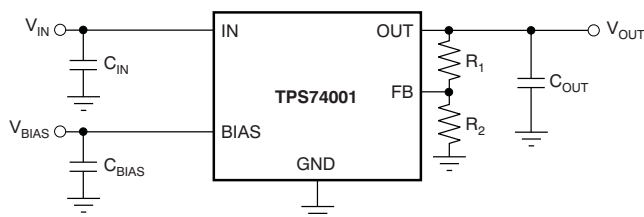

**Typical Application Circuit (Adjustable)**



Please be aware that an important notice concerning availability, standard warranty, and use in critical applications of Texas Instruments semiconductor products and disclaimers thereto appears at the end of this data sheet.

Jr S-PAK is a trademark of Texas Instruments Incorporated.

All other trademarks are the property of their respective owners.



This integrated circuit can be damaged by ESD. Texas Instruments recommends that all integrated circuits be handled with appropriate precautions. Failure to observe proper handling and installation procedures can cause damage.

ESD damage can range from subtle performance degradation to complete device failure. Precision integrated circuits may be more susceptible to damage because very small parametric changes could cause the device not to meet its published specifications.

### ORDERING INFORMATION<sup>(1)</sup>

PRODUCT	V <sub>OUT</sub> <sup>(2)</sup>
TPS740xx yyy z	<b>XX</b> is nominal output voltage (for example, 12 = 1.2 V, 15 = 1.5 V, 01 = Adjustable). <sup>(3)</sup> <b>YYY</b> is package designator. <b>Z</b> is package quantity.

- (1) For the most current package and ordering information, see the Package Option Addendum at the end of this document, or visit the device product folder at [www.ti.com](http://www.ti.com).
- (2) Fixed output voltages of 1.2 V is available; minimum order quantities may apply. Contact factory for details and availability.
- (3) For fixed 0.9-V operation, tie FB to OUT.

### ABSOLUTE MAXIMUM RATINGS<sup>(1)</sup>

Over operating free-air temperature range (unless otherwise noted).

		VALUE		UNIT
		MIN	MAX	
Voltage	IN, BIAS	-0.3	+6.5	V
	EN, FB, OUT	-0.3	V <sub>BIAS</sub> + 0.3 <sup>(2)</sup>	V
Current	OUT	Internally limited		A
Electrostatic discharge rating <sup>(3)</sup>	Human body model (HBM, JESD22-A114A)	2		kV
	Charged device model (CDM, JESD22-C101B.01)	500		V

- (1) Stresses beyond those listed under *Absolute Maximum Ratings* may cause permanent damage to the device. These are stress ratings only, and functional operation of the device at these or any other conditions beyond those indicated is not implied. Exposure to absolute-maximum-rated conditions for extended periods may affect device reliability.
- (2) The absolute maximum rating is V<sub>BIAS</sub> + 0.3 V or +6.0 V, whichever is smaller.
- (3) ESD testing is performed according to the respective JESD22 JEDEC standard.

**THERMAL INFORMATION**

THERMAL METRIC <sup>(1)(2)</sup>		TPS74001DGK	TPS74001DPT <sup>(3)</sup>	UNITS
		DGK (4 pin short)	DPT	
		8 PINS	5 PINS	
$\theta_{JA}$	Junction-to-ambient thermal resistance <sup>(4)</sup>	136.9	30.0	°C/W
$\theta_{JCTop}$	Junction-to-case (top) thermal resistance <sup>(5)</sup>	35.3	15.3	
$\theta_{JB}$	Junction-to-board thermal resistance <sup>(6)</sup>	68.0	14.4	
$\psi_{JT}$	Junction-to-top characterization parameter <sup>(7)</sup>	0.9	0.6	
$\psi_{JB}$	Junction-to-board characterization parameter <sup>(8)</sup>	67.8	14.4	
$\theta_{JCbott}$	Junction-to-case (bottom) thermal resistance <sup>(9)</sup>	n/a	5.8	

- (1) For more information about traditional and new thermal metrics, see the [IC Package Thermal Metrics](#) application report, [SPRA953A](#).
- (2) For thermal estimates of this device based on PCB copper area, see the [TI PCB Thermal Calculator](#).
- (3) Thermal data for the DGK and DPT packages are derived by thermal simulations based on JEDEC-standard methodology as specified in the JESD51 series. The following assumptions are used in the simulations:
  - (a) DPT only, the exposed pad is connected to the PCB ground layer through a 8 × 8 thermal via array.
  - (b) i. DPT: Each of top and bottom copper layers has a dedicated pattern for 20% copper coverage.  
ii. DGK: The top copper layer has a dedicated pattern of 5% copper coverage and the bottom copper layer has another dedicated pattern of 20% copper coverage.
  - (c) These data were generated with only a single device at the center of a JEDEC high-K (2s2p) board with 3in × 3in copper area.
- (4) The junction-to-ambient thermal resistance under natural convection is obtained in a simulation on a JEDEC-standard, high-K board, as specified in JESD51-7, in an environment described in JESD51-2a.
- (5) The junction-to-case (top) thermal resistance is obtained by simulating a cold plate test on the top of the package. No specific JEDEC-standard test exists, but a close description can be found in the ANSI SEMI standard G30-88.
- (6) The junction-to-board thermal resistance is obtained by simulating in an environment with a ring cold plate fixture to control the PCB temperature, as described in JESD51-8.
- (7) The junction-to-top characterization parameter,  $\psi_{JT}$ , estimates the junction temperature of a device in a real system and is extracted from the simulation data to obtain  $\theta_{JA}$  using a procedure described in JESD51-2a (sections 6 and 7).
- (8) The junction-to-board characterization parameter,  $\psi_{JB}$ , estimates the junction temperature of a device in a real system and is extracted from the simulation data to obtain  $\theta_{JA}$  using a procedure described in JESD51-2a (sections 6 and 7).
- (9) The junction-to-case (bottom) thermal resistance is obtained by simulating a cold plate test on the exposed (power) pad. No specific JEDEC standard test exists, but a close description can be found in the ANSI SEMI standard G30-88.

## ELECTRICAL CHARACTERISTICS

Over operating temperature range ( $T_J = -40^\circ\text{C}$  to  $+125^\circ\text{C}$ ),  $V_{\text{BIAS}} = V_{\text{OUT}} + 2.0\text{ V}$ ,  $V_{\text{IN}} = V_{\text{OUT}} + 1\text{ V}$ ,  $C_{\text{OUT}} = 10\text{ }\mu\text{F}$ , following [Recommended Resistor Values](#), and  $V_{\text{EN}} = 1.1\text{ V}$ , unless otherwise noted. Typical values are at  $T_J = +25^\circ\text{C}$ . TPS74001 (adjustable output voltage) is tested at  $V_{\text{OUT}} = 0.9\text{ V}$ .

PARAMETER		TEST CONDITIONS	TPS740xx			UNIT
			MIN	TYP	MAX	
$V_{\text{IN}}$	Input voltage range		1.2		6.0	V
$V_{\text{BIAS}}$	Bias pin voltage range		2.9		6.0	V
$V_{\text{OUT}}$	Accuracy <sup>(1)</sup>	$T_J = 25^\circ\text{C}$	-1		1	%
		$T_J = -40^\circ\text{C}$ to $+125^\circ\text{C}$	-2		2	%
$V_{\text{OUT}}/V_{\text{IN}}$	Line regulation	$V_{\text{IN}} = V_{\text{OUT}} + 1\text{ V}$ to $6.0\text{ V}$	-0.1	0.01	0.1	%/V
$V_{\text{OUT}}/I_{\text{OUT}}$	Load regulation	$I_{\text{LOAD}} = 0\text{ mA}$ to $1.5\text{ A}$ <sup>(2)</sup>			1.5	%
$V_{\text{DO}}$	$V_{\text{IN}}$ dropout voltage <sup>(3)</sup>	$I_{\text{LOAD}} = 1.5\text{ A}$		100	300	mV
	$V_{\text{BIAS}}$ dropout voltage <sup>(3)</sup>	$I_{\text{LOAD}} = 1.5\text{ A}$ , $V_{\text{IN}} = V_{\text{BIAS}}$		1.3	1.6	V
$I_{\text{GND}}$	Ground pin current <sup>(4)</sup>	$I_{\text{LOAD}} = 1.5\text{ A}$		2	3	mA
$I_{\text{SHDN}}$	Shutdown supply current ( $I_{\text{GND}}$ )	Fixed output version only. $V_{\text{EN}} \leq 0.4\text{ V}$ , $T_J = -40^\circ\text{C}$ to $+85^\circ\text{C}$ , $V_{\text{OUT}} = 0\text{ V}$		1	5	$\mu\text{A}$
$I_{\text{BIAS}}$	Bias pin current	$I_{\text{LOAD}} = 1.5\text{ A}$			2	mA
$I_{\text{CL}}$	Current limit	$V_{\text{OUT}} = 80\% \times V_{\text{OUT}}(\text{NOM})$	1.6		6.0	A
$V_{\text{EN, HI}}$	Enable input high level		1.1		6.0	V
$V_{\text{EN, LO}}$	Enable input low level	$R_{\text{LOAD}} = 1\text{ k}\Omega$ to GND	0		0.4	V
$I_{\text{EN}}$	Enable pin current	$V_{\text{EN}} = 1.5\text{ V}$		0.1	1	$\mu\text{A}$
$T_J$	Operating junction temperature		-40		+125	$^\circ\text{C}$
$T_{\text{SD}}$	Thermal shutdown temperature	Shutdown, temperature increasing		+165		$^\circ\text{C}$
		Reset, temperature decreasing		+140		
$V_{\text{REF}}$	Reference voltage		0.882	0.9	0.918	V

- (1) Adjustable output voltage devices: resistor tolerance is not taken into account.  
 (2) With a fixed output device, this test condition is  $I_{\text{LOAD}} = 50\text{ mA}$  to  $1.5\text{ A}$ .  
 (3) Dropout is defined as the voltage from the input voltage to  $V_{\text{OUT}}$  when  $V_{\text{OUT}}$  is 3% below nominal.  
 (4)  $I_{\text{GND}}(\text{MAX}) = 3\text{ mA}$  includes the maximum  $2\text{ mA}$  of  $I_{\text{BIAS}}$ .

**FUNCTIONAL BLOCK DIAGRAMS**

**Adjustable Output Voltage Version**

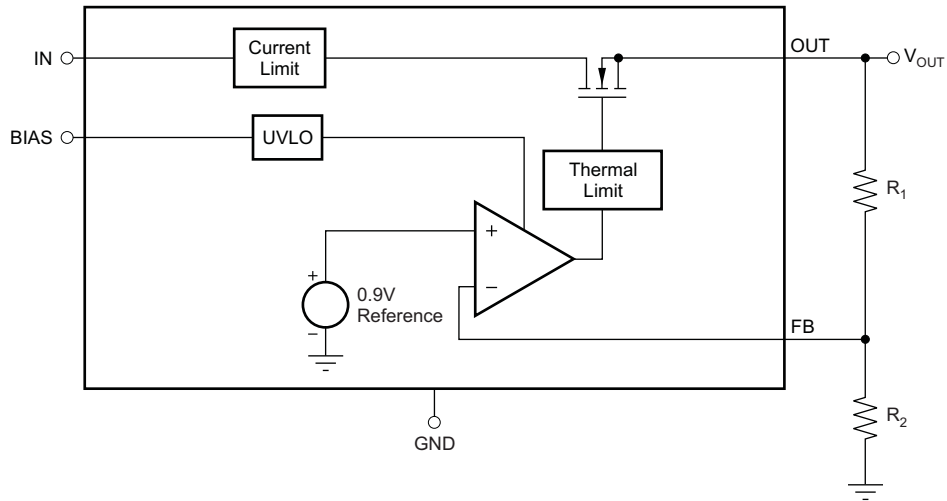

**Figure 1.**

**Fixed Output Voltage Version**

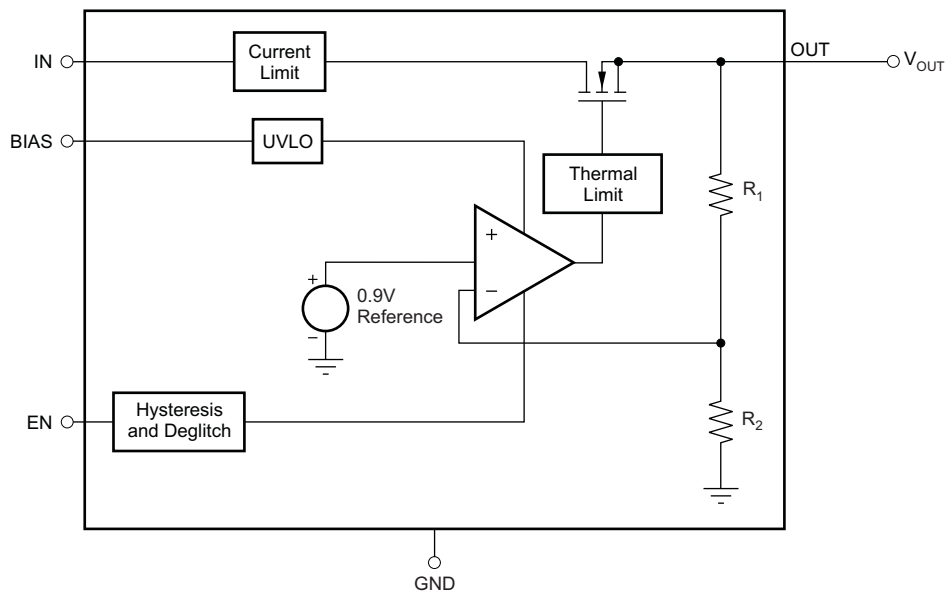

**Figure 2.**

### PIN CONFIGURATION

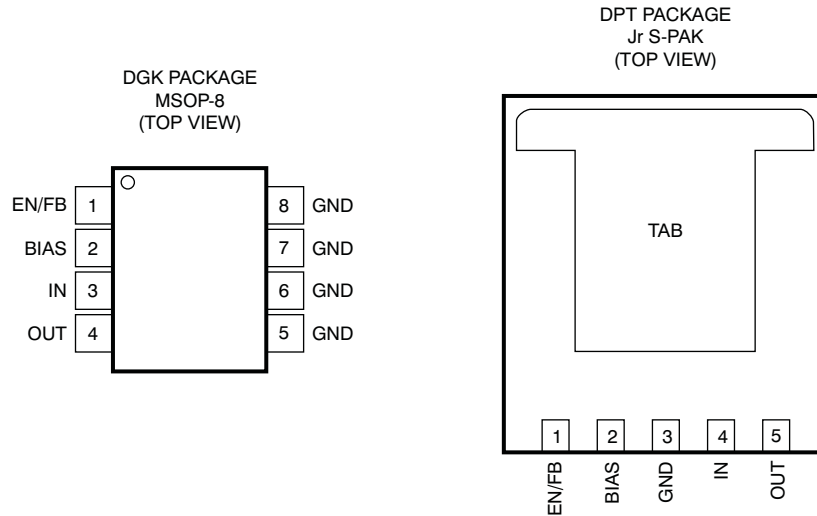

**Table 1. TERMINAL FUNCTIONS**

TERMINAL			DESCRIPTION
NAME	DGK (MSOP-8)	DPT (Jr S-PAK)	
EN	1	1	Enable pin; fixed output voltage version only. Driving this pin high enables the regulator; driving this pin low puts the regulator into shutdown mode. This pin must not be left unconnected.
FB	1	1	Feedback pin; adjustable output voltage version only. The feedback connection to the center tap of an external resistor divider network that sets the output voltage. This pin must not be left floating.
BIAS	2	2	Bias input voltage for error amplifier, reference, and internal control circuits.
IN	3	4	Input to the device.
OUT	4	5	Regulated output voltage. A small capacitor (total typical capacitance $\geq 2.2 \mu\text{F}$ , ceramic) is needed from this pin to ground to assure stability.
GND	5-8	3	Ground
TAB		TAB	Internally connected to ground

**TYPICAL CHARACTERISTICS**

At  $T_J = +25^\circ\text{C}$ ,  $V_{IN} = 2.5\text{ V}$ ,  $V_{BIAS} = 5.0\text{ V}$ ,  $V_{OUT(\text{target})} = 1.5\text{ V}$ ,  $V_{EN} = V_{BIAS}$ ,  $C_{IN} = 2.2\ \mu\text{F}$ ,  $C_{BIAS} = 2.2\ \mu\text{F}$ , and  $C_{OUT} = 10\ \mu\text{F}$ , unless otherwise noted.

**POWER-SUPPLY RIPPLE REJECTION (INPUT SUPPLY)**

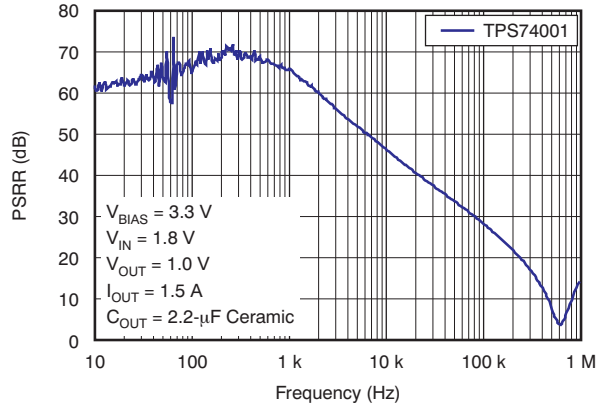

**Figure 3.**

**POWER-SUPPLY RIPPLE REJECTION (BIAS SUPPLY)**

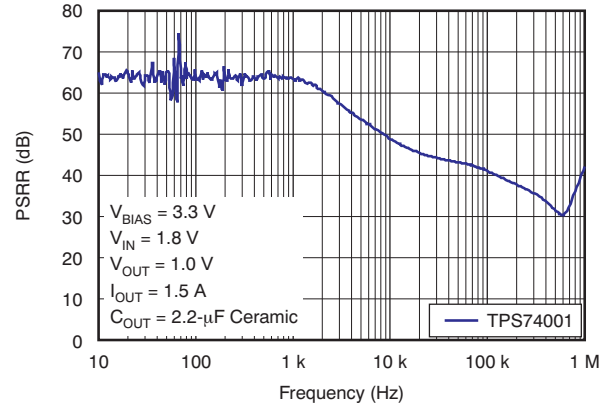

**Figure 4.**

**DROPOUT VOLTAGE (INPUT SUPPLY)**

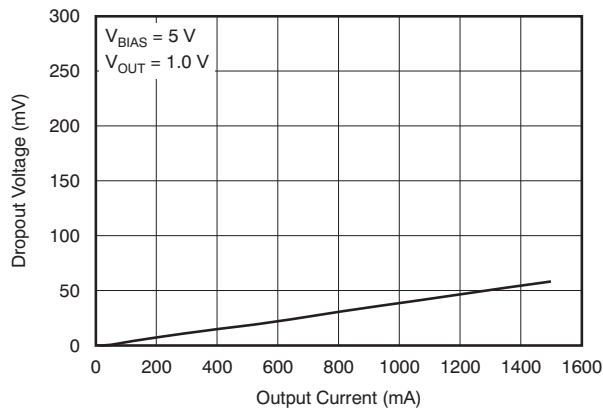

**Figure 5.**

**DROPOUT VOLTAGE (BIAS SUPPLY)**

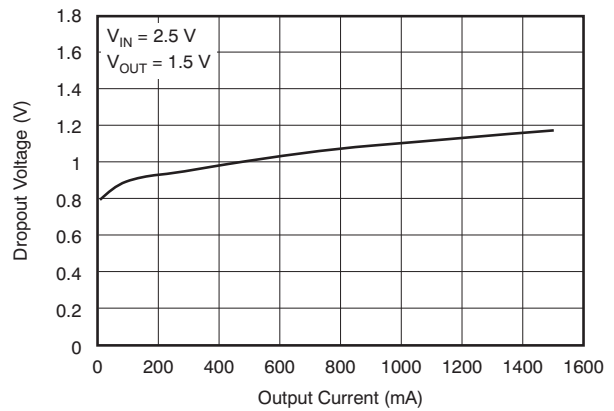

**Figure 6.**

**DROPOUT VOLTAGE vs TEMPERATURE (INPUT SUPPLY)**

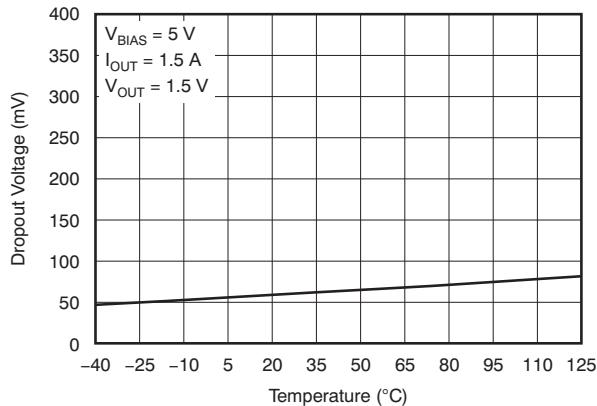

**Figure 7.**

**DROPOUT VOLTAGE vs TEMPERATURE (BIAS SUPPLY)**

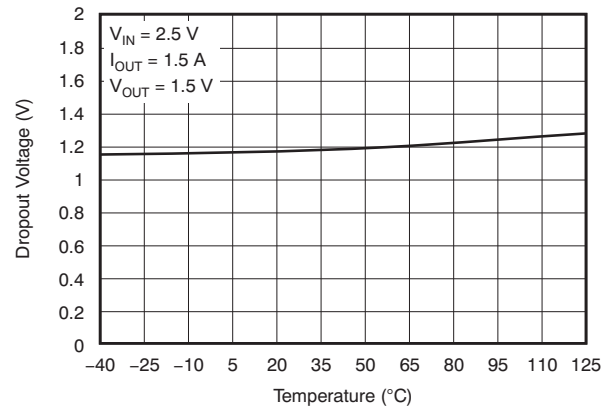
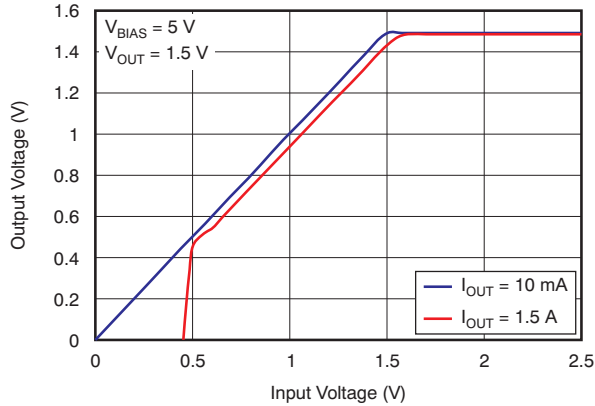

**Figure 8.**

**TYPICAL CHARACTERISTICS (continued)**

At  $T_J = +25^\circ\text{C}$ ,  $V_{IN} = 2.5\text{ V}$ ,  $V_{BIAS} = 5.0\text{ V}$ ,  $V_{OUT(target)} = 1.5\text{ V}$ ,  $V_{EN} = V_{BIAS}$ ,  $C_{IN} = 2.2\ \mu\text{F}$ ,  $C_{BIAS} = 2.2\ \mu\text{F}$ , and  $C_{OUT} = 10\ \mu\text{F}$ , unless otherwise noted.

**DROPOUT CHARACTERISTICS (INPUT VOLTAGE)**



**Figure 9.**

**DROPOUT CHARACTERISTICS (BIAS VOLTAGE)**

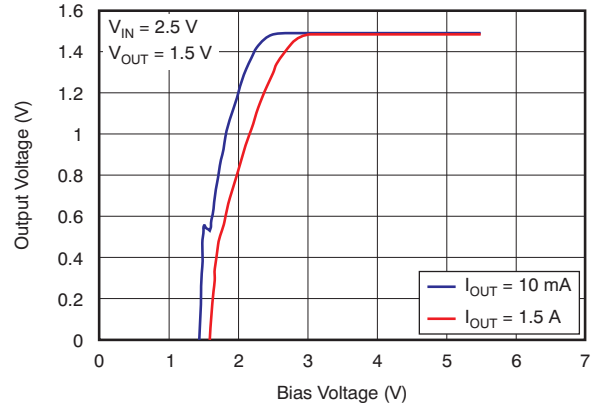

**Figure 10.**

**LOAD REGULATION**

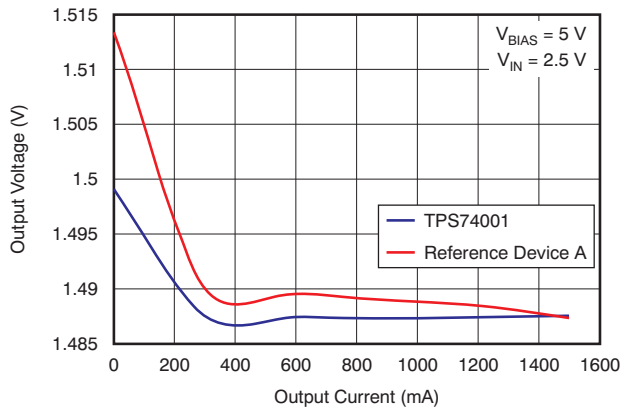

**Figure 11.**

**MAXIMUM BIAS CURRENT vs BIAS VOLTAGE<sup>(1)</sup>**

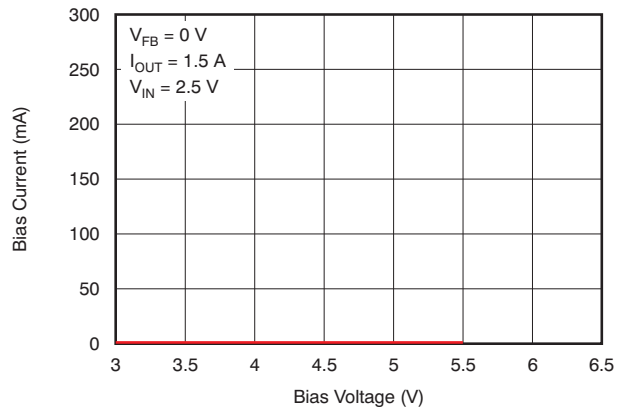

**Figure 12.**

**MAXIMUM BIAS CURRENT vs TEMPERATURE**

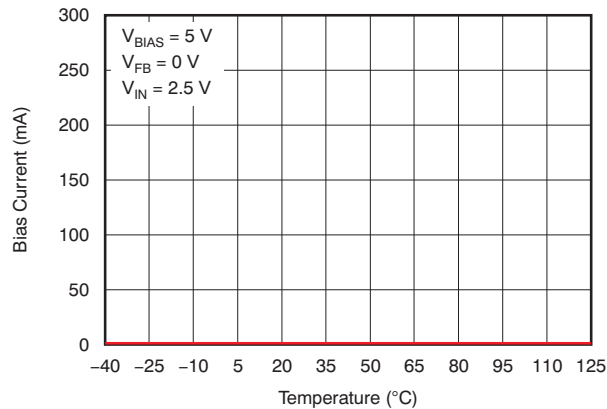

**Figure 13.**

**BIAS CURRENT vs TEMPERATURE**

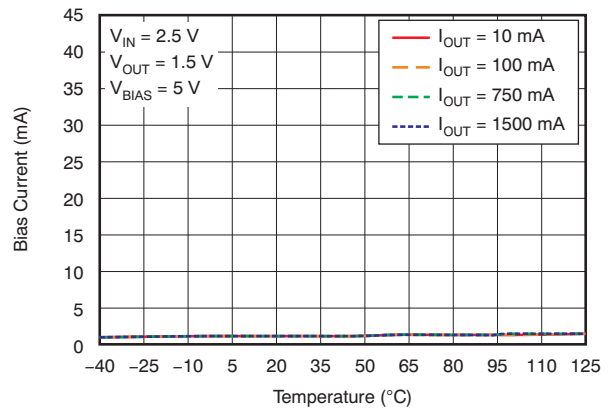
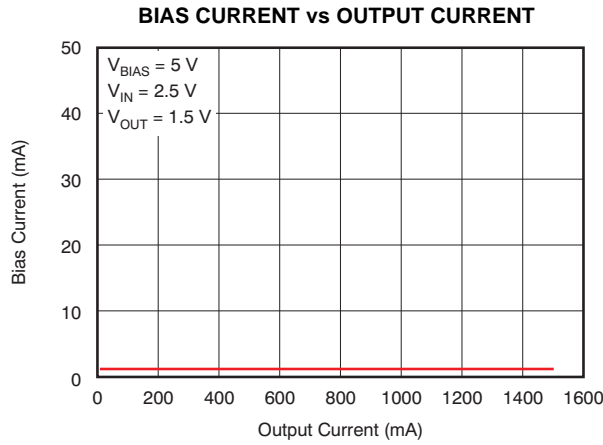

**Figure 14.**

(1) This device does not show large bias current at any condition.

**TYPICAL CHARACTERISTICS (continued)**

At  $T_J = +25^\circ\text{C}$ ,  $V_{IN} = 2.5\text{ V}$ ,  $V_{BIAS} = 5.0\text{ V}$ ,  $V_{OUT(target)} = 1.5\text{ V}$ ,  $V_{EN} = V_{BIAS}$ ,  $C_{IN} = 2.2\ \mu\text{F}$ ,  $C_{BIAS} = 2.2\ \mu\text{F}$ , and  $C_{OUT} = 10\ \mu\text{F}$ , unless otherwise noted.



**Figure 15.**

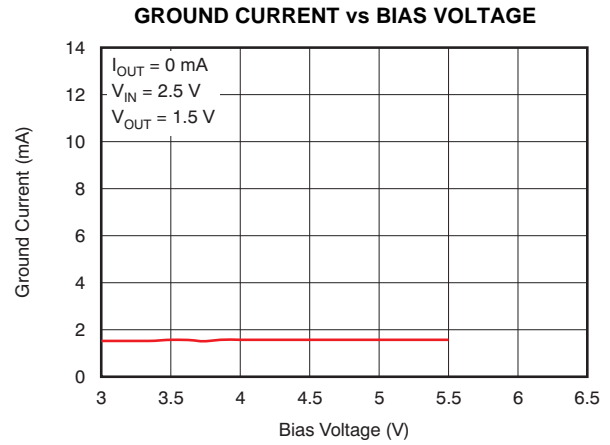

**Figure 16.**

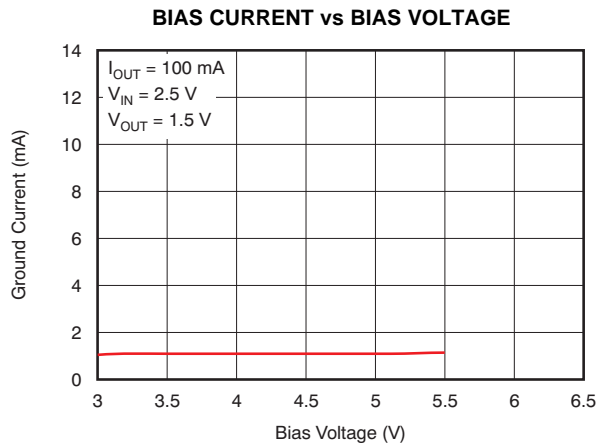

**Figure 17.**

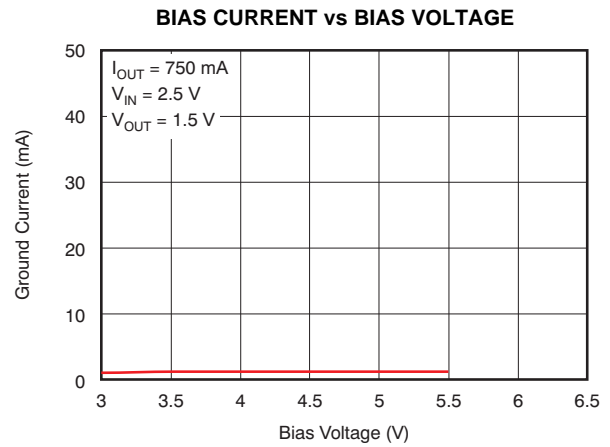

**Figure 18.**

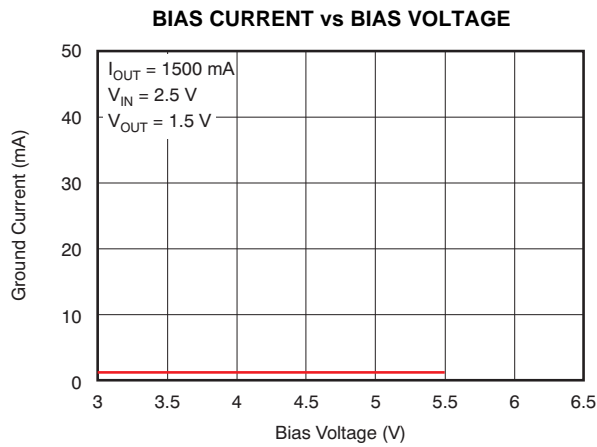

**Figure 19.**

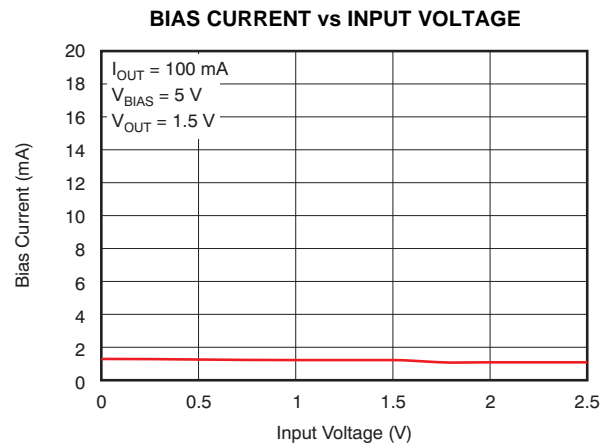

**Figure 20.**

**TYPICAL CHARACTERISTICS (continued)**

At  $T_J = +25^\circ\text{C}$ ,  $V_{IN} = 2.5\text{ V}$ ,  $V_{BIAS} = 5.0\text{ V}$ ,  $V_{OUT(target)} = 1.5\text{ V}$ ,  $V_{EN} = V_{BIAS}$ ,  $C_{IN} = 2.2\ \mu\text{F}$ ,  $C_{BIAS} = 2.2\ \mu\text{F}$ , and  $C_{OUT} = 10\ \mu\text{F}$ , unless otherwise noted.

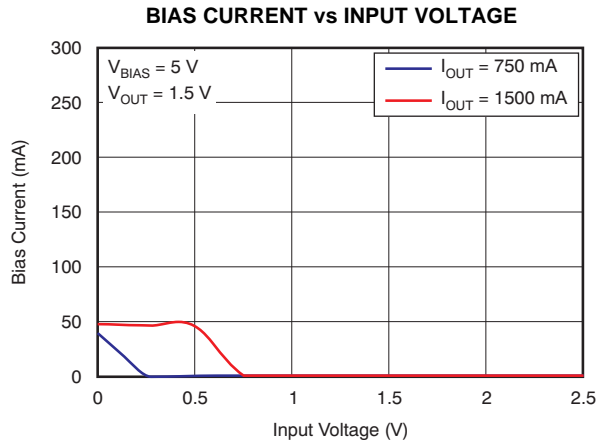

Figure 21.

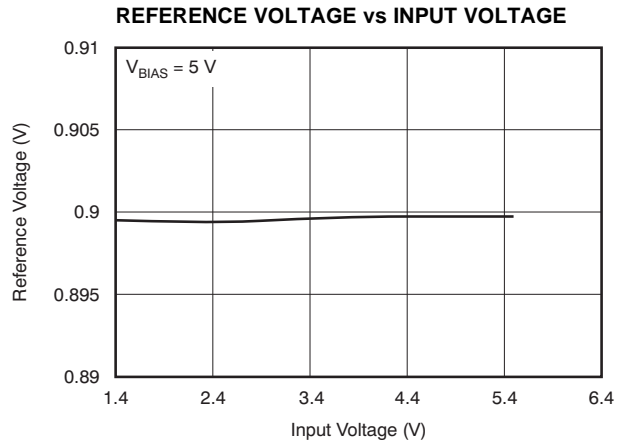

Figure 22.

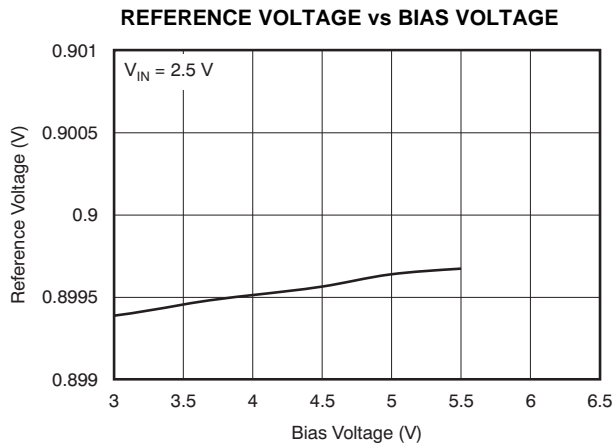

Figure 23.

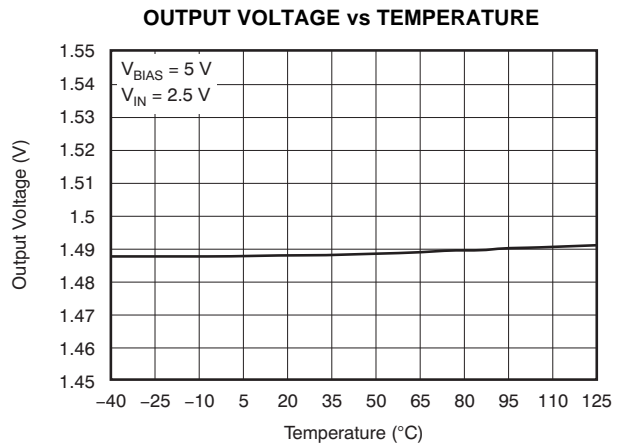

Figure 24.

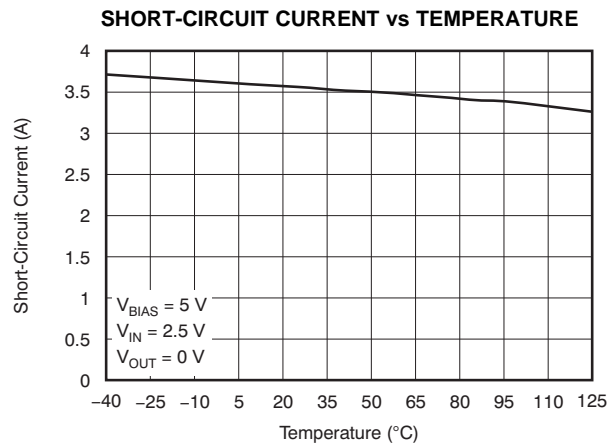

Figure 25.

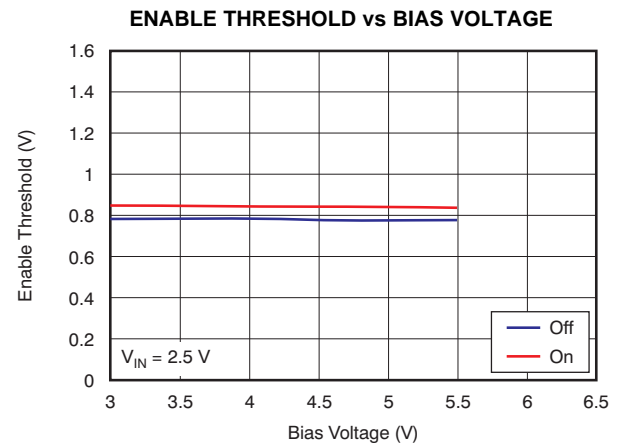

Figure 26.

**TYPICAL CHARACTERISTICS (continued)**

At  $T_J = +25^\circ\text{C}$ ,  $V_{IN} = 2.5\text{ V}$ ,  $V_{BIAS} = 5.0\text{ V}$ ,  $V_{OUT(target)} = 1.5\text{ V}$ ,  $V_{EN} = V_{BIAS}$ ,  $C_{IN} = 2.2\ \mu\text{F}$ ,  $C_{BIAS} = 2.2\ \mu\text{F}$ , and  $C_{OUT} = 10\ \mu\text{F}$ , unless otherwise noted.

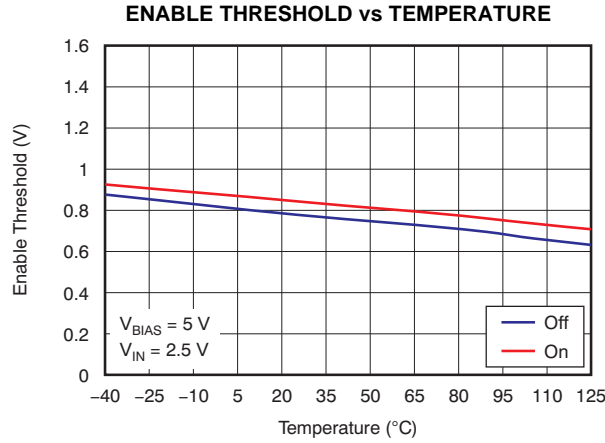

Figure 27.

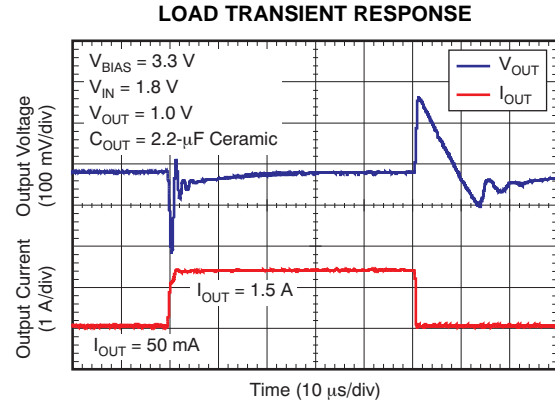

Figure 28.

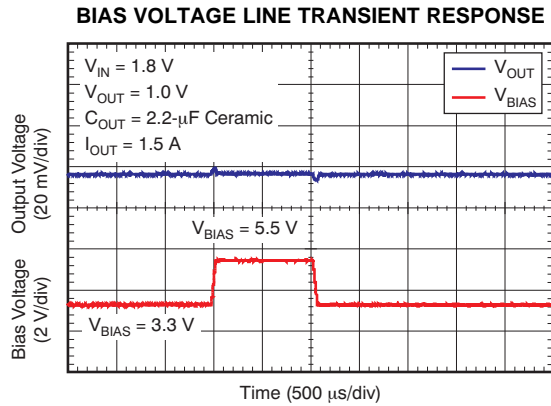

Figure 29.

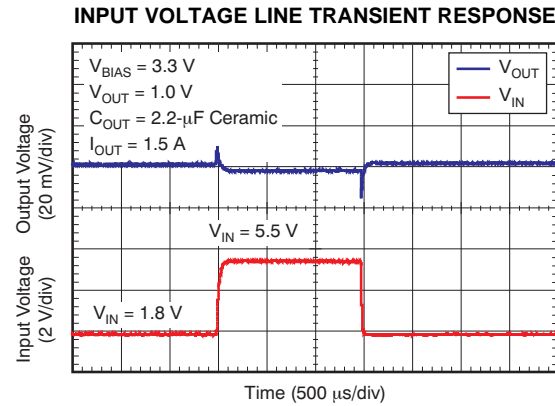

Figure 30.

## APPLICATION INFORMATION

The TPS740xx belongs to a family of low dropout (LDO) regulators. These regulators use a low-current bias input to power all internal control circuitry, allowing the NMOS-pass transistor to regulate very low input and output voltages.

The use of an NMOS-pass FET offers several critical advantages for many applications. Unlike a PMOS topology device, the output capacitor has little effect on loop stability. This architecture allows the TPS740xx to be stable with any capacitor type of 2.2  $\mu\text{F}$  or greater. Transient response is also superior to PMOS topologies, particularly for low  $V_{\text{IN}}$  applications.

With the fixed output voltage version, an enable (EN) pin with hysteresis and deglitch allows slow-ramping signals to be used for sequencing the device. The low  $V_{\text{IN}}$  and  $V_{\text{OUT}}$  capability is ideal for inexpensive, easy-to-design, and efficient linear regulation between the multiple supply voltages often present in processor-intensive systems.

Figure 31 illustrates the typical application circuit for the TPS74001 adjustable output device.

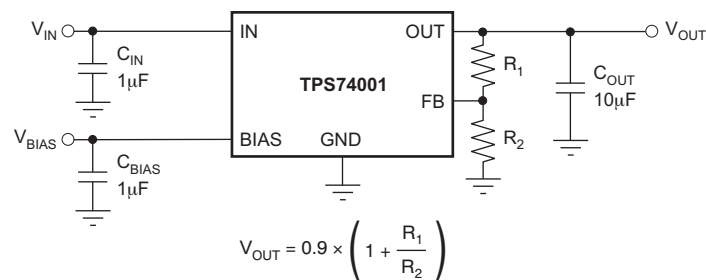

**Figure 31. Typical Application Circuit for the TPS74001 (Adjustable)**

$R_1$  and  $R_2$  can be calculated for any output voltage using the formula shown in Figure 31. Table 2 lists sample resistor values of common output voltages. In order to achieve the maximum accuracy specifications,  $R_2$  is recommended to be lower than 4.99 k $\Omega$ .

Figure 32 illustrates the typical application circuit for the TPS740xx fixed output device.

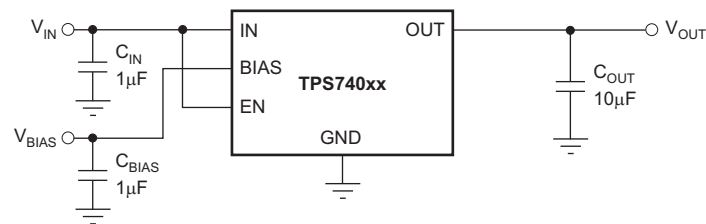

**Figure 32. Typical Application Circuit for the TPS740xx (Fixed Voltage Versions)**

**Table 2. Standard 1% Resistor Values for Programming the Output Voltage**

R <sub>1</sub> (kΩ)	R <sub>2</sub> (kΩ)	V <sub>OUT</sub> (V)
Short	Open	0.9
0.562	5.11	1.0
0.75	4.53	1.05
1.07	4.99	1.1
1.58	4.75	1.2
1.91	2.87	1.5
2.43	2.43	1.8
3.01	1.69	2.5
4.22	1.58	3.3
5.23	1.74	3.6

## INPUT, OUTPUT, AND BIAS CAPACITOR REQUIREMENTS

The device is designed to be stable for all available types and values of output capacitors greater than or equal to 2.2 μF. The device is also stable with multiple capacitors in parallel, which can be of any type or value.

The capacitance required on the IN and BIAS pins strongly depends on the input supply source impedance. To counteract any inductance in the input, the minimum recommended capacitor for V<sub>IN</sub> and V<sub>BIAS</sub> is 1 μF. If V<sub>IN</sub> and V<sub>BIAS</sub> are connected to the same supply, the recommended minimum capacitor for V<sub>BIAS</sub> is 4.7 μF. Good-quality, low-ESR capacitors should be used on the input; ceramic X5R and X7R capacitors are preferred. These capacitors should be placed as close to the pins as possible for optimum performance.

## TRANSIENT RESPONSE

The TPS740xx is designed to have excellent transient response for most applications with a small amount of output capacitance. In some cases, the transient response may be limited by the transient response of the input supply. This limitation is especially true in applications where the difference between the input and output is less than 300 mV. In these cases, adding additional input capacitance improves the transient response much more than simply adding additional output capacitance. With a solid input supply, adding additional output capacitance reduces undershoot and overshoot during a transient event; refer to the [Typical Characteristics](#) section. Because the TPS740xx is stable with output capacitors as low as 2.2 μF, many applications may then need very little capacitance at the LDO output. For these applications, local bypass capacitance for the powered device may be sufficient to meet the transient requirements of the application. This design reduces the total solution cost by avoiding the need to use expensive, high-value capacitors at the LDO output.

## DROPOUT VOLTAGE

The TPS740xx offers very low dropout performance, making it well-suited for high-current, low  $V_{IN}$ /low  $V_{OUT}$  applications. The low dropout of the TPS740xx allows the device to be used in place of a dc/dc converter and still achieve good efficiency. This performance provides designers with the power architecture for the application to achieve the smallest, simplest, and lowest cost solution.

There are two different specifications for dropout voltage with the TPS740xx. The first specification (shown in [Figure 33](#)) is referred to as  $V_{IN}$  Dropout and is used when an external bias voltage is applied to achieve low dropout. This specification assumes that  $V_{BIAS}$  is at least 2.0 V above  $V_{OUT}$ . If  $V_{BIAS}$  is higher than  $V_{OUT} + 2.0$  V,  $V_{IN}$  dropout is less than specified.

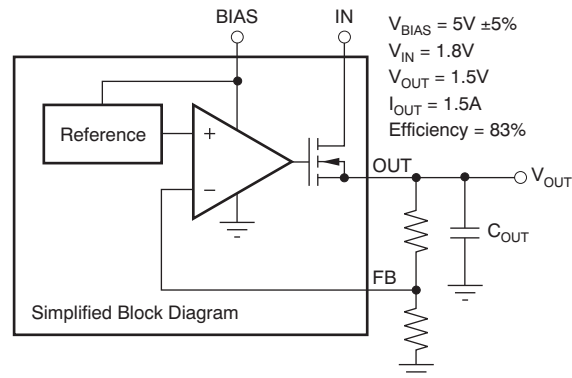

**Figure 33. Typical Application of the TPS74001 Using an Auxiliary Bias Rail**

The second specification (shown in [Figure 34](#)) is referred to as  $V_{BIAS}$  Dropout and applies to applications where IN and BIAS are tied together. This option allows the device to be used in applications where an auxiliary bias voltage is not available or low dropout is not required. Dropout is limited by BIAS in these applications because  $V_{BIAS}$  provides the gate drive to the pass FET; therefore,  $V_{BIAS}$  must be 2.0 V above  $V_{OUT}$ . Because of this usage, when IN and BIAS are tied together they easily consume large amounts of power. Do not to exceed the power rating of the IC package.

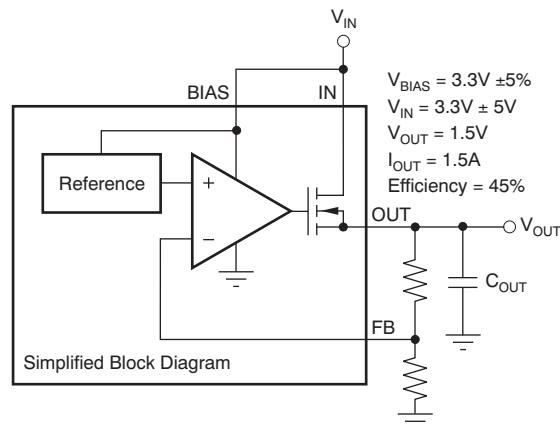

**Figure 34. Typical Application of the TPS74001 Without an Auxiliary Bias Rail**

## SEQUENCING REQUIREMENTS

$V_{IN}$ ,  $V_{BIAS}$ , and  $V_{EN}$  can be sequenced in any order without causing damage to the device.

**NOTE:** When  $V_{BIAS}$  and  $V_{EN}$  are present and  $V_{IN}$  is not supplied, this device outputs approximately 50  $\mu\text{A}$  of current from OUT. Although this condition does not cause any damage to the device, the output current may charge up the OUT node if total resistance between OUT and GND (including external feedback resistors) is greater than 10 k $\Omega$ .

## ENABLE/SHUTDOWN (Fixed Voltage Version Only)

The enable (EN) pin is active high and is compatible with standard digital signaling levels. When  $V_{EN}$  is below 0.4 V, it turns the regulator off; when  $V_{EN}$  is above 1.1 V, it turns the regulator on. Unlike many regulators, the enable circuitry has hysteresis and deglitching for use with relatively slow ramping analog signals. This configuration allows the TPS740xx to be enabled by connecting the output of another supply to the EN pin. The enable circuitry typically has 50 mV of hysteresis and a deglitch circuit to help avoid on/off cycling as a result of small glitches in the  $V_{EN}$  signal.

The enable threshold is typically 0.8 V and varies with temperature and process variations. Temperature variation is approximately  $-1 \text{ mV}/^\circ\text{C}$ ; process variation accounts for most of the rest of the variation to the 0.4 V and 1.1 V limits. If precise turn-on timing is required, a fast rise-time signal must be used to enable the TPS740xx.

If not used, EN can be connected to either IN or BIAS. If EN is connected to IN, it should be connected as close as possible to the largest capacitance on the input to prevent voltage droops on that line from triggering the enable circuit.

## INTERNAL CURRENT LIMIT

The TPS740xx features a current limit that is flat over temperature and supply voltage. The current limit responds in approximately 10 $\mu\text{s}$  to reduce the current during a short-circuit fault.

The internal current limit protection circuitry of the TPS740xx is designed to protect against overload conditions. It is not intended to allow operation above the rated current of the device. Continuously running the TPS740xx above the rated current degrades device reliability.

## THERMAL PROTECTION

Thermal protection disables the output when the junction temperature rises to approximately  $+160^\circ\text{C}$ , allowing the device to cool. When the junction temperature cools to approximately  $+140^\circ\text{C}$ , the output circuitry is enabled. Depending on power dissipation, thermal resistance, and ambient temperature the thermal protection circuit may cycle on and off. This cycling limits the dissipation of the regulator, protecting it from damage as a result of overheating.

Activation of the thermal protection circuit indicates excessive power dissipation or inadequate heatsinking. For reliable operation, junction temperature should be limited to  $+125^\circ\text{C}$  maximum. To estimate the margin of safety in a complete design (including heatsink), increase the ambient temperature until thermal protection is triggered; use worst-case loads and signal conditions. For good reliability, thermal protection should trigger at least  $+40^\circ\text{C}$  above the maximum expected ambient condition of the application. This condition produces a worst-case junction temperature of  $+125^\circ\text{C}$  at the highest expected ambient temperature and worst-case load.

The internal protection circuitry of the TPS740xx is designed to protect against overload conditions. It is not intended to replace proper heatsinking. Continuously running the TPS740xx into thermal shutdown degrades device reliability.

## LAYOUT RECOMMENDATIONS AND POWER DISSIPATION

An optimal layout can greatly improve transient performance, PSRR, and noise. To minimize the voltage drop on the input of the device during load transients, the capacitance on IN and BIAS should be connected as close as possible to the device. This capacitance also minimizes the effects of parasitic inductance and resistance of the input source and can, therefore, improve stability. To achieve optimal transient performance and accuracy, the top side of R<sub>1</sub> in [Figure 31](#) should be connected as close as possible to the load. If BIAS is connected to IN, it is recommended to connect BIAS as close to the sense point of the input supply as possible. This connection minimizes the voltage drop on BIAS during transient conditions and can improve the turn-on response.

Knowing the device power dissipation and proper sizing of the thermal plane that is connected to the thermal pad is critical to avoiding thermal shutdown and ensuring reliable operation. Power dissipation of the device depends on input voltage and load conditions and can be calculated using [Equation 1](#):

$$PD = (V_{IN} - V_{OUT}) \times I_{OUT} \quad (1)$$

Power dissipation can be minimized and greater efficiency can be achieved by using the lowest possible input voltage necessary to achieve the required output voltage regulation.

On the DGK (MSOP-8) package, the primary conduction path for heat is through four GND pins (right side of the IC) to the printed circuit board (PCB). On the DPT (Jr S-PAK) package, the primary conduction path for heat is through the tab to the PCB. This tab should be connected to ground. On both packages, ground pattern on PCB should have an appropriate amount of copper PCB area to ensure the device does not overheat. The maximum junction-to-ambient thermal resistance depends on the maximum ambient temperature, maximum device junction temperature, and power dissipation of the device and can be calculated using [Equation 2](#):

$$R_{\theta JA} = \frac{(+125^{\circ}\text{C} - T_A)}{P_D} \quad (2)$$

## REVISION HISTORY

NOTE: Page numbers for previous revisions may differ from page numbers in the current version.

<b>Changes from Revision B (November 2011) to Revision C</b>	<b>Page</b>
• Changed upper voltage in both sub-bullets of second Features bullet .....	1
• Changed input supply description in the <i>Description</i> section .....	1
• Changed $V_{OUT}$ parameter test conditions in Electrical Characteristics table .....	4
• Added footnote 2 to Electrical Characteristics table .....	4
• Changed $V_{EN, HI}$ parameter maximum specification in Electrical Characteristics table .....	4

<b>Changes from Revision A (June 2011) to Revision B</b>	<b>Page</b>
• Changed <i>Voltage IN, BIAS</i> parameter maximum specification in Absolute Maximum Ratings table .....	2
• Changed $V_{IN}$ and $V_{BIAS}$ parameter maximum specifications in Electrical Characteristics table .....	4

## PACKAGING INFORMATION

Orderable Device	Status (1)	Package Type	Package Drawing	Pins	Package Qty	Eco Plan (2)	Lead/Ball Finish (6)	MSL Peak Temp (3)	Op Temp (°C)	Device Marking (4/5)	Samples
TPS74001DGKR	ACTIVE	VSSOP	DGK	8	2500	Green (RoHS & no Sb/Br)	CU NIPDAUAG	Level-2-260C-1 YEAR	-40 to 125	QXE	<a href="#">Samples</a>
TPS74001DGKT	ACTIVE	VSSOP	DGK	8	250	Green (RoHS & no Sb/Br)	CU NIPDAUAG	Level-2-260C-1 YEAR	-40 to 125	QXE	<a href="#">Samples</a>
TPS74012DGKR	ACTIVE	VSSOP	DGK	8	2500	Green (RoHS & no Sb/Br)	CU NIPDAUAG	Level-2-260C-1 YEAR	-40 to 125	QXF	<a href="#">Samples</a>
TPS74012DGKT	ACTIVE	VSSOP	DGK	8	250	Green (RoHS & no Sb/Br)	CU NIPDAUAG	Level-2-260C-1 YEAR	-40 to 125	QXF	<a href="#">Samples</a>

(1) The marketing status values are defined as follows:

**ACTIVE:** Product device recommended for new designs.

**LIFEBUY:** TI has announced that the device will be discontinued, and a lifetime-buy period is in effect.

**NRND:** Not recommended for new designs. Device is in production to support existing customers, but TI does not recommend using this part in a new design.

**PREVIEW:** Device has been announced but is not in production. Samples may or may not be available.

**OBSOLETE:** TI has discontinued the production of the device.

(2) Eco Plan - The planned eco-friendly classification: Pb-Free (RoHS), Pb-Free (RoHS Exempt), or Green (RoHS & no Sb/Br) - please check <http://www.ti.com/productcontent> for the latest availability information and additional product content details.

**TBD:** The Pb-Free/Green conversion plan has not been defined.

**Pb-Free (RoHS):** TI's terms "Lead-Free" or "Pb-Free" mean semiconductor products that are compatible with the current RoHS requirements for all 6 substances, including the requirement that lead not exceed 0.1% by weight in homogeneous materials. Where designed to be soldered at high temperatures, TI Pb-Free products are suitable for use in specified lead-free processes.

**Pb-Free (RoHS Exempt):** This component has a RoHS exemption for either 1) lead-based flip-chip solder bumps used between the die and package, or 2) lead-based die adhesive used between the die and leadframe. The component is otherwise considered Pb-Free (RoHS compatible) as defined above.

**Green (RoHS & no Sb/Br):** TI defines "Green" to mean Pb-Free (RoHS compatible), and free of Bromine (Br) and Antimony (Sb) based flame retardants (Br or Sb do not exceed 0.1% by weight in homogeneous material)

(3) MSL, Peak Temp. - The Moisture Sensitivity Level rating according to the JEDEC industry standard classifications, and peak solder temperature.

(4) There may be additional marking, which relates to the logo, the lot trace code information, or the environmental category on the device.

(5) Multiple Device Markings will be inside parentheses. Only one Device Marking contained in parentheses and separated by a "~" will appear on a device. If a line is indented then it is a continuation of the previous line and the two combined represent the entire Device Marking for that device.

(6) Lead/Ball Finish - Orderable Devices may have multiple material finish options. Finish options are separated by a vertical ruled line. Lead/Ball Finish values may wrap to two lines if the finish value exceeds the maximum column width.

**Important Information and Disclaimer:** The information provided on this page represents TI's knowledge and belief as of the date that it is provided. TI bases its knowledge and belief on information provided by third parties, and makes no representation or warranty as to the accuracy of such information. Efforts are underway to better integrate information from third parties. TI has taken and continues to take reasonable steps to provide representative and accurate information but may not have conducted destructive testing or chemical analysis on incoming materials and chemicals. TI and TI suppliers consider certain information to be proprietary, and thus CAS numbers and other limited information may not be available for release.

In no event shall TI's liability arising out of such information exceed the total purchase price of the TI part(s) at issue in this document sold by TI to Customer on an annual basis.

## TAPE AND REEL INFORMATION



### QUADRANT ASSIGNMENTS FOR PIN 1 ORIENTATION IN TAPE



\*All dimensions are nominal

Device	Package Type	Package Drawing	Pins	SPQ	Reel Diameter (mm)	Reel Width W1 (mm)	A0 (mm)	B0 (mm)	K0 (mm)	P1 (mm)	W (mm)	Pin1 Quadrant
TPS74001DGKR	VSSOP	DGK	8	2500	330.0	12.4	5.3	3.4	1.4	8.0	12.0	Q1
TPS74001DGKT	VSSOP	DGK	8	250	180.0	12.4	5.3	3.4	1.4	8.0	12.0	Q1
TPS74012DGKR	VSSOP	DGK	8	2500	330.0	12.4	5.3	3.4	1.4	8.0	12.0	Q1
TPS74012DGKT	VSSOP	DGK	8	250	180.0	12.4	5.3	3.4	1.4	8.0	12.0	Q1

**TAPE AND REEL BOX DIMENSIONS**

\*All dimensions are nominal

Device	Package Type	Package Drawing	Pins	SPQ	Length (mm)	Width (mm)	Height (mm)
TPS74001DGKR	VSSOP	DGK	8	2500	367.0	367.0	35.0
TPS74001DGKT	VSSOP	DGK	8	250	210.0	185.0	35.0
TPS74012DGKR	VSSOP	DGK	8	2500	367.0	367.0	35.0
TPS74012DGKT	VSSOP	DGK	8	250	210.0	185.0	35.0





- NOTES:
- A. All linear dimensions are in millimeters.
  - B. This drawing is subject to change without notice.
  - C. Publication IPC-7351 is recommended for alternate designs.
  - D. Laser cutting apertures with trapezoidal walls and also rounding corners will offer better paste release. Customers should contact their board assembly site for stencil design recommendations. Refer to IPC-7525 for other stencil recommendations.
  - E. Customers should contact their board fabrication site for solder mask tolerances between and around signal pads.

## IMPORTANT NOTICE AND DISCLAIMER

TI PROVIDES TECHNICAL AND RELIABILITY DATA (INCLUDING DATASHEETS), DESIGN RESOURCES (INCLUDING REFERENCE DESIGNS), APPLICATION OR OTHER DESIGN ADVICE, WEB TOOLS, SAFETY INFORMATION, AND OTHER RESOURCES "AS IS" AND WITH ALL FAULTS, AND DISCLAIMS ALL WARRANTIES, EXPRESS AND IMPLIED, INCLUDING WITHOUT LIMITATION ANY IMPLIED WARRANTIES OF MERCHANTABILITY, FITNESS FOR A PARTICULAR PURPOSE OR NON-INFRINGEMENT OF THIRD PARTY INTELLECTUAL PROPERTY RIGHTS.

These resources are intended for skilled developers designing with TI products. You are solely responsible for (1) selecting the appropriate TI products for your application, (2) designing, validating and testing your application, and (3) ensuring your application meets applicable standards, and any other safety, security, or other requirements. These resources are subject to change without notice. TI grants you permission to use these resources only for development of an application that uses the TI products described in the resource. Other reproduction and display of these resources is prohibited. No license is granted to any other TI intellectual property right or to any third party intellectual property right. TI disclaims responsibility for, and you will fully indemnify TI and its representatives against, any claims, damages, costs, losses, and liabilities arising out of your use of these resources.

TI's products are provided subject to TI's Terms of Sale ([www.ti.com/legal/termsofsale.html](http://www.ti.com/legal/termsofsale.html)) or other applicable terms available either on [ti.com](http://ti.com) or provided in conjunction with such TI products. TI's provision of these resources does not expand or otherwise alter TI's applicable warranties or warranty disclaimers for TI products.

Mailing Address: Texas Instruments, Post Office Box 655303, Dallas, Texas 75265  
Copyright © 2019, Texas Instruments Incorporated

## Looking for pricing, stock, or lifecycle information?

Click below to explore more details on WIN SOURCE:

 [View TPS74012DGKT on WIN SOURCE](#)

 [Texas Instruments](#) Information

## Optimize Your Supply Chain with WIN SOURCE Solutions

-  Global Sourcing Solution
-  Obsolete Management
-  Cost Control Management
-  Shortage Management
-  Alternative Solution
-  Excess Inventory Management