



**THE DATASHEET OF
AD7414ARTZ-1REEL7**



FEATURES

10-bit temperature-to-digital converter
Temperature range: -40°C to +125°C
Typical accuracy of ±0.5°C at +40°C
SMBus/I²C-compatible serial interface
3 µA power-down current
Temperature conversion time: 29 µs typ
Space-saving 6-lead (AD7414) and 5-lead (AD7415)

SOT-23 packages

Pin selectable addressing via AS
Overtemperature indicator (AD7414 Only)
SMBus alert function (AD7414 only)
4 versions allow 8 I²C addresses (AD7414)
2 versions allow 6 I²C addresses (AD7415)

APPLICATIONS

Hard disk drives
Personal computers
Electronic test equipment
Office equipment
Domestic appliances
Process control
Cellular phones

GENERAL DESCRIPTION

The AD7414/AD7415 are complete temperature monitoring systems in 6-lead and 5-lead SOT-23 packages. They contain a band gap temperature sensor and a 10-bit ADC to monitor and digitize the temperature reading to a resolution of 0.25°C.

The AD7414/AD7415 provide a 2-wire serial interface that is compatible with SMBus and I²C interfaces. The parts come in four versions: the AD7414/AD7415-0, AD7414/AD7415-1, AD7414-2, and AD7414-3. The AD7414/AD7415-0 and AD7414/AD7415-1 versions provide a choice of three different SMBus addresses for each version. All four AD7414 versions give the possibility of eight different I²C addresses while the two AD7415 versions allow up to six I²C addresses to be used.

The AD7414/AD7415's 2.7 V supply voltage, low supply current, serial interface, and small package size make them ideal for a variety of applications, including personal computers, office equipment, cellular phones, and domestic appliances.

In the AD7414, on-chip registers can be programmed with high and low temperature limits, and an open-drain overtemperature indicator output (ALERT) becomes active when a programmed

Rev. F

Information furnished by Analog Devices is believed to be accurate and reliable. However, no responsibility is assumed by Analog Devices for its use, nor for any infringements of patents or other rights of third parties that may result from its use. Specifications subject to change without notice. No license is granted by implication or otherwise under any patent or patent rights of Analog Devices. Trademarks and registered trademarks are the property of their respective owners.

FUNCTIONAL BLOCK DIAGRAM

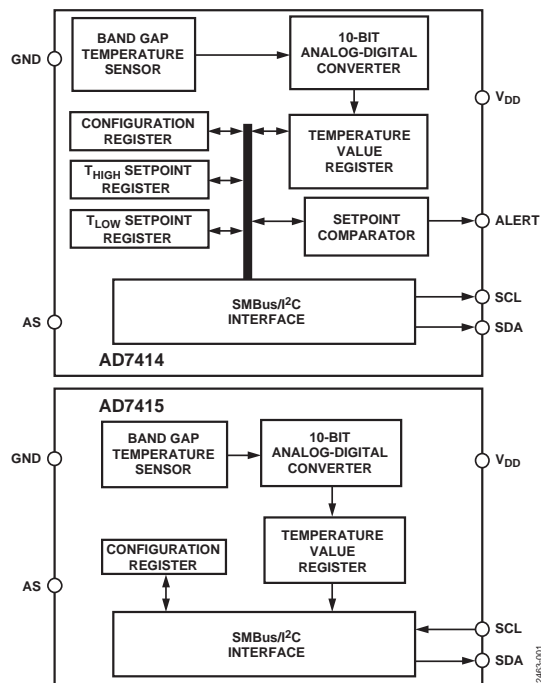

Figure 1.

limit is exceeded. A configuration register allows programming of the state of the ALERT output (active high or active low). This output can be used as an interrupt or as an SMBus alert.

PRODUCT HIGHLIGHTS

1. On-chip temperature sensor. The sensor allows an accurate measurement of the ambient temperature to be made. It is capable of ±0.5°C temperature accuracy.
2. SMBus/I²C-compatible serial interface. The interface offers pin selectable choice of three addresses per version of the AD7414/AD7415, eight address options in total for the AD7414, and six in total for the AD7415.
3. Supply voltage of 2.7 V to 5.5 V.
4. Space-saving 5-lead and 6-lead SOT-23 packages.
5. 10-bit temperature reading to 0.25°C resolution.
6. Overtemperature indicator. This indicator can be software disabled. It is used as an interrupt of SMBus alert.
7. One-shot and automatic temperature conversion rates.

TABLE OF CONTENTS

Specifications	3	Serial Interface	12
Absolute Maximum Ratings	5	Serial Bus Address.....	12
ESD Caution	5	Write Mode	12
Pin Configurations and Function Descriptions.....	6	Read Mode	12
Theory of Operation	7	SMBus ALERT.....	13
Circuit Information	7	Power-On Defaults	13
Functional Description.....	7	Operating Modes	13
Measurement Technique.....	7	Power vs. Throughput	14
Temperature Data Format.....	8	Mounting the AD7414/AD7415	14
Internal Register Structure.....	9	Supply Decoupling.....	14
Address Pointer Register	9	Temperature Accuracy vs. Supply.....	15
Configuration Register (Address 0X01)	9	Typical Temperature Error Graph	15
Temperature Value Register (Address 0X00).....	10	Outline Dimensions.....	16
AD7414 T _{HIGH} Register (Address 0X02)	10	Ordering Guide	18
AD7414 T _{LOW} Register (Address 0X03)	10		

REVISION HISTORY

11/10—Rev. E to Rev. F

Added Data Hold Time, t_T Parameter, Table 1	4
Changes to Figure 2.....	4
Updated to Outline Dimensions	16
Changes to Ordering Guide.....	18

4/05—Rev. D to Rev. E

Updated Format.....	Universal
Changes to Absolute Maximum Ratings.....	6
Changes to Figure 6.....	7
Changes to Ordering Guide.....	17

9/04—Rev. C to Rev. D.

Changes to Absolute Maximum Ratings.....	3
Updated Ordering Guide	4

8/03—Rev. B to Rev. C.

Change to Temperature Range	Universal
Updated Features.....	1
Updated Specifications	2
Updated Absolute Maximum Ratings	3
Updated Ordering Guide	4

Updated Circuit Information	5
Updated Temperature Data Format.....	6
Updated Temperature Value Register.....	8
Updated Figure 14.....	11
Updated Outline Dimensions.....	12

11/02—Rev. A to Rev. B.

Changes to Absolute Maximum Ratings.....	3
--	---

10/02—Rev. 0 to Rev. A.

Changes to Specifications	2
Changes to Pin Function Descriptions	3
Changes to Absolute Maximum Ratings.....	3
Ordering Guide Updated	4
Change to Figure 2.....	5
Added to Typical Temperature Error Graph section	11
Added Figure 15	11
Outline Dimensions updated	12

7/01—Revision 0: Initial Version

SPECIFICATIONS

$T_A = T_{MIN}$ to T_{MAX} , $V_{DD} = 2.7$ V to 5.5 V, unless otherwise noted. Temperature range as follows: A version = -40°C to $+125^{\circ}\text{C}$.

Table 1.

Parameter	A Version	Unit	Test Conditions/Comments
TEMPERATURE SENSOR AND ADC			
Accuracy ¹	± 0.5 -0.87 to $+0.82^2$ ± 1.5 ± 2.0 ± 3.0 ± 2.0 $\pm 1.87^2$ ± 2.0 ± 3.0 ± 3.0	$^{\circ}\text{C}$ typ $^{\circ}\text{C}$ max $^{\circ}\text{C}$ max $^{\circ}\text{C}$ max $^{\circ}\text{C}$ max $^{\circ}\text{C}$ typ $^{\circ}\text{C}$ max $^{\circ}\text{C}$ typ $^{\circ}\text{C}$ max $^{\circ}\text{C}$ typ $^{\circ}\text{C}$ max $^{\circ}\text{C}$ typ	$V_{DD} = 3$ V @ $+40^{\circ}\text{C}$ $V_{DD} = 3$ V @ $+40^{\circ}\text{C}$ $V_{DD} = 3$ V @ -40°C to $+70^{\circ}\text{C}$ $V_{DD} = 3$ V @ -40°C to $+85^{\circ}\text{C}$ $V_{DD} = 3$ V @ -40°C to $+125^{\circ}\text{C}$ $V_{DD} = 3$ V @ -40°C to $+125^{\circ}\text{C}$ $V_{DD} = 5.5$ V @ $+40^{\circ}\text{C}$ $V_{DD} = 5.5$ V @ -40°C to $+85^{\circ}\text{C}$ $V_{DD} = 5.5$ V @ -40°C to $+85^{\circ}\text{C}$ $V_{DD} = 5.5$ V @ -40°C to $+125^{\circ}\text{C}$
Resolution	10	Bits	
Update Rate, t_R	800	ms typ	
Temperature Conversion Time	25	μs typ	
POWER SUPPLIES			
Supply Current ³			
Peak Supply Current ⁴	1.2	mA typ	Current during conversion
Supply Current – Nonconverting	900	μA max	Peak current between conversions
Inactive Serial Bus ⁵			
Normal Mode @ 3 V	169	μA typ	Supply current with serial bus inactive. Part not converting and D7 of configuration register = 0.
Normal Mode @ 5 V	188	μA typ	
Active Serial Bus ⁶			
Normal Mode @ 3 V	180	μA typ	Supply current with serial bus active. Part not converting and D7 of configuration register = 0.
Normal Mode @ 5 V	214	μA typ	
Shutdown Mode	3	μA max	D7 of configuration register = 1. Typical values are 0.04 μA at 3 V and 0.5 μA at 5 V.
DIGITAL INPUT			
Input High Voltage, V_{IH}	2.4	V min	
Input Low Voltage, V_{IL}	0.8	V max	
Input Current, I_{IN}^7	± 1	μA max	$V_{IN} = 0$ V to V_{DD}
Input Capacitance, C_{IN}	10	pF max	All digital inputs
DIGITAL OUTPUT (OPEN-DRAIN)			
Output High Voltage, V_{OH}	2.4	V min	
Output Low Voltage, V_{OL}	0.4	V max	$I_{OL} = 1.6$ mA
Output High Current, I_{OH}	1	μA max	$V_{OH} = 5$ V
Output Capacitance, C_{OUT}	10	pF max	Typ = 3 pF
ALERT Output Saturation Voltage	0.8	V max	$I_{OUT} = 4$ mA

AD7414/AD7415

Parameter	A Version	Unit	Test Conditions/Comments
AC ELECTRICAL CHARACTERISTICS ^{8, 9}			
Serial Clock Period, t_1	2.5	$\mu\text{s min}$	See Figure 2
Data In Setup Time to SCL High, t_2	50	ns min	See Figure 2
Data Out Stable after SCL Low, t_3	0	ns min	See Figure 2
SDA Low Setup Time to SCL Low (Start Condition), t_4	50	ns min	See Figure 2
SDA High Hold Time after SCL High (Stop Condition), t_5	50	ns min	See Figure 2
SDA and SCL Fall Time, t_6	90	ns max	See Figure 2
Data Hold Time, t_7	35	ns min	See Figure 2
Power-Up Time	4	$\mu\text{s typ}$	

¹ Accuracy specifications apply only to voltages listed under Test Conditions. See Temperature Accuracy vs. Supply section for typical accuracy performance over the full V_{DD} supply range.

² 100% production tested at 40°C to these limits.

³ These current values can be used to determine average power consumption at different one-shot conversion rates. Average power consumption at the automatic conversion rate of 1.25 kHz is 940 μW .

⁴ This peak supply current is required for 29 μs (the conversion time plus power-up time) out of every 800 μs (the conversion rate).

⁵ These current values are derived by not issuing a stop condition at the end of a write or read, thus preventing the part from going into a conversion.

⁶ The current is derived assuming a 400 kHz serial clock being active continuously.

⁷ On power-up, the initial input current, I_{IN} , on the AS pin is typically 50 μA .

⁸ The SDA and SCL timing is measured with the input filters turned on so as to meet the fast mode I²C specification. Switching off the input filters improves the transfer rate but has a negative effect on the EMC behavior of the part.

⁹ Guaranteed by design. Not tested in production.

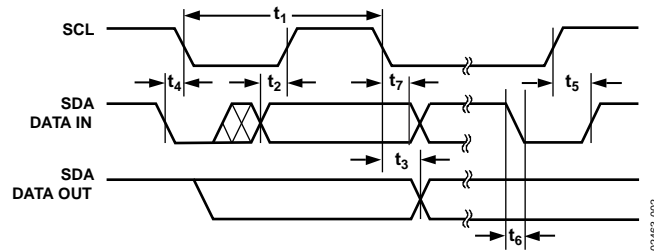

Figure 2. Diagram for Serial Bus Timing

ABSOLUTE MAXIMUM RATINGS

Table 2.

Parameter	Rating
V _{DD} to GND	−0.3 V to +7 V
SDA Input Voltage to GND	−0.3 V to +7 V
SDA Output Voltage to GND	−0.3 V to +7 V
SCL Input Voltage to GND	−0.3 V to +7 V
ALERT Output Voltage to GND	−0.3 V to +7 V
Operating Temperature Range	−40°C to +125°C
Storage Temperature Range	−65°C to +150°C
Junction Temperature	150°C
5-Lead SOT-23 (RJ-5)	
Power Dissipation ^{1, 2}	$W_{MAX} = (T_{JMAX} - T_A)/\theta_{JA}$
Thermal Impedance ³	
θ_{JA} , Junction-to-Ambient (still air)	240°C/W
6-Lead SOT-23 (RJ-6)	
Power Dissipation ^{1, 2}	$W_{MAX} = (T_{JMAX} - T_A)/\theta_{JA}$
Thermal Impedance ³	
θ_{JA} , Junction-to-Ambient (still air)	190.4°C/W
8-Lead MSOP (RM-8)	
Power Dissipation ^{1, 2}	$W_{MAX} = (T_{JMAX} - T_A)/\theta_{JA}$
Thermal Impedance ³	
θ_{JA} , Junction-to-Ambient (still air)	205.9°C/W
θ_{JC} , Junction-to-Case	43.74°C/W
IR Reflow Soldering	
Peak Temperature	220°C (0°C/5°C)
Time at Peak Temperature	10 sec to 20 sec
Ramp-up Rate	3°C/s max
Ramp-down Rate	−6°C/s max
Ramp from 25°C to Peak Temperature	6 minutes max
IR Reflow Soldering in Pb-Free Package	
Peak Temperature	260°C (0°C)
Time at Peak Temperature	20 sec to 40 sec
Ramp Rate	3°C/s max
Ramp-Down Rate	−6°C/s max
Ramp from 25°C to Peak Temperature	8 minutes max

¹ Values relate to package being used on a standard 2-layer PCB.

² T_A = ambient temperature.

³ Junction-to-case resistance is applicable to components featuring a preferential flow direction, such as components mounted on a heat sink. Junction-to-ambient resistance is more useful for air-cooled, PCB-mounted components.

Stresses above those listed under Absolute Maximum Ratings may cause permanent damage to the device. This is a stress rating only; functional operation of the device at these or any other conditions above those indicated in the operational section of this specification is not implied. Exposure to absolute maximum rating conditions for extended periods may affect device reliability.

ESD CAUTION



ESD (electrostatic discharge) sensitive device.

Charged devices and circuit boards can discharge without detection. Although this product features patented or proprietary protection circuitry, damage may occur on devices subjected to high energy ESD. Therefore, proper ESD precautions should be taken to avoid performance degradation or loss of functionality.

AD7414/AD7415

PIN CONFIGURATIONS AND FUNCTION DESCRIPTIONS

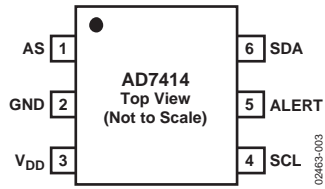

Figure 3. AD7414 Pin Configuration (SOT-23)

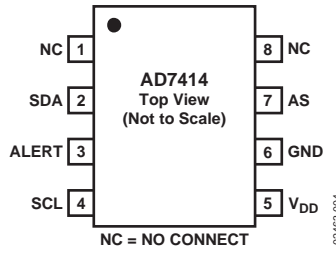

Figure 4. AD7414 Pin Configuration (MSOP)

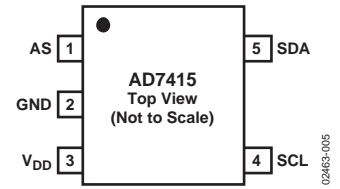

Figure 5. AD7415 Pin Configuration (SOT-23)

Table 3. Pin Function Descriptions

Mnemonic	Description
AS	Logic Input. Address select input that selects one of three I ² C addresses for the AD7414/AD7415 (see Table 4). Recommend a pull-up or pull-down resistor of 1 k Ω .
GND	Analog and Digital Ground.
V _{DD}	Positive Supply Voltage, 2.7 V to 5.5 V.
SDA	Digital I/O. Serial bus bidirectional data. Open-drain output.
ALERT	AD7414 Digital Output. Overtemperature indicator becomes active when temperature exceeds T _{HIGH} . Open-drain output.
SCL	Digital Input. Serial bus clock.

Table 4. I²C Address Selection

Part Number	AS Pin	I ² C Address
AD7414-0	Float	1001 000
AD7414-0	GND	1001 001
AD7414-0	V _{DD}	1001 010
AD7414-1	Float	1001 100
AD7414-1	GND	1001 101
AD7414-1	V _{DD}	1001 110
AD7414-2	N/A	1001 011
AD7414-3	N/A	1001 111
AD7415-0	Float	1001 000
AD7415-0	GND	1001 001
AD7415-0	V _{DD}	1001 010
AD7415-1	Float	1001 100
AD7415-1	GND	1001 101
AD7415-1	V _{DD}	1001 110

THEORY OF OPERATION

CIRCUIT INFORMATION

The AD7414/AD7415 are standalone digital temperature sensors. The on-chip temperature sensor allows an accurate measurement of the ambient device temperature to be made. The 10-bit analog-to-digital converter converts the temperature measured into a twos complement format for storage in the temperature register. The ADC is made up of a conventional successive-approximation converter based around a capacitor digital-to-analog (DAC). The serial interface is I²C- and SMBus-compatible. The AD7414/AD7415 require a 2.7 V to 5.5 V power supply. The temperature sensor has a working measurement range of -40°C to $+125^{\circ}\text{C}$.

FUNCTIONAL DESCRIPTION

Temperature measurement is initiated by two methods. The first uses an internal clock countdown of 800 ms, and a conversion is performed. The internal oscillator is the only circuit that is powered up between conversions, and once it times out, every 800 ms, a wake-up signal is sent to power up the rest of the circuitry. A monostable is activated at the beginning of the wake-up signal to ensure that sufficient time is given to the power-up process. The monostable typically takes 4 μs to time out. It then takes typically 25 μs for each conversion to be completed. The new temperature value is loaded into the temperature value register and ready for reading by the I²C interface.

A temperature measurement is also initiated every time the one-shot method is used. This method requires the user to write to the one-shot bit in the configuration register when a temperature measurement is needed. Setting the one-shot bit to 1 starts a temperature conversion directly after the write operation. The track-and-hold goes into hold approximately 4 μs (monostable time out) after the STOP condition, and a conversion is then initiated. Typically 25 μs later, the conversion is complete and the temperature value register is loaded with a new temperature value.

The measurement modes are compared with a high temperature limit, stored in an 8-bit read/write register. This is applicable only to the AD7414, because the AD7415 does not have an ALERT pin and subsequently does not have an overtemperature monitoring function. If the measurement is greater than the high limit, the ALERT pin is activated (if it has already been enabled in the configuration register). There are two ways to deactivate the ALERT pin again: when the alert reset bit in the configuration register is set to 1 by a write operation, and when the temperature measured is less than the value in the T_{LOW} register. This ALERT pin is compatible with the SMBus SMBALERT option.

Configuration functions consist of

- Switching between normal operation and full power-down
- Enabling or disabling the SCL and SDA filters
- Enabling or disabling the ALERT function
- Setting the ALERT pin polarity

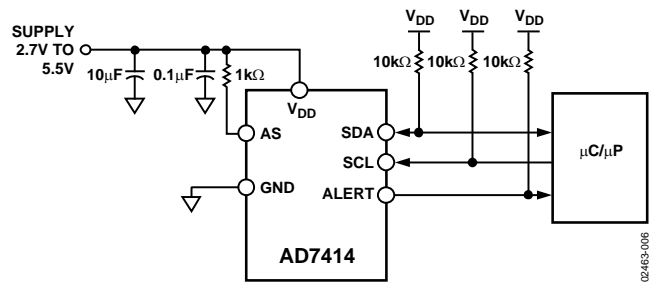

Figure 6. Typical Connection Diagram

MEASUREMENT TECHNIQUE

A common method of measuring temperature is to exploit the negative temperature coefficient of a diode, or the base-emitter voltage of a transistor, operated at constant current. Unfortunately, this technique requires calibration to null the effect of the absolute value of V_{BE} , which varies from device to device. The technique used in the AD7414/AD7415 is to measure the change in V_{BE} when the device is operated at two different currents. This is given by

$$\Delta V_{BE} = KT/q \times \ln(N)$$

where:

K is Boltzmann's constant.

q is the charge on the electron (1.6×10^{-19} Coulombs).

T is the absolute temperature in Kelvins.

N is the ratio of the two currents.

AD7414/AD7415

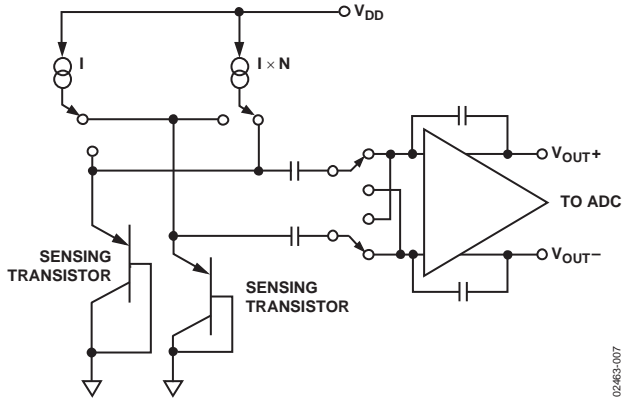

Figure 7. Temperature Measurement Technique

Figure 7 shows the method the AD7414/AD7415 use to measure the ambient device temperature. To measure ΔV_{BE} , the sensor (substrate transistor) is switched between operating currents of I and $N \times I$. The resulting waveform is passed through a chopper stabilized amplifier that performs the functions of amplification and rectification of the waveform to produce a dc voltage proportional to ΔV_{BE} . This voltage is measured by the ADC to give a temperature output in 10-bit, twos complement format.

TEMPERATURE DATA FORMAT

The temperature resolution of the ADC is 0.25°C , which corresponds to 1 LSB of the ADC. The ADC can theoretically measure a temperature span of 255°C ; the lowest practical value is limited to -40°C due to the device maximum ratings. The A grade can measure a temperature range of -40°C to $+125^\circ\text{C}$. (Temperature data format is shown in Table 5.)

Table 5. A Grade Temperature Data Format

Temperature	Digital Output DB9...DB0
-55°C	11 0010 0100
-50°C	11 0011 1000
-25°C	11 1001 1100
-0.25°C	11 1111 1111
0°C	00 0000 0000
$+0.25^\circ\text{C}$	00 0000 0001
$+10^\circ\text{C}$	00 0010 1000
$+25^\circ\text{C}$	00 0110 0100
$+50^\circ\text{C}$	00 1100 1000
$+75^\circ\text{C}$	01 0010 1100
$+100^\circ\text{C}$	01 1001 0000
$+125^\circ\text{C}$	01 1111 0100

The grade temperature conversion formula follows:

$$\text{Positive Temperature} = \frac{\text{ADC Code } (d)}{4}$$

$$\text{Negative Temperature} = \frac{\text{ADC Code } (d) - 512}{4}$$

Note that DB9 is removed from the ADC code in the negative temperature formula.

INTERNAL REGISTER STRUCTURE

The AD7414 has five internal registers, as shown in Figure 8. Four are data registers, and one is an address pointer register.

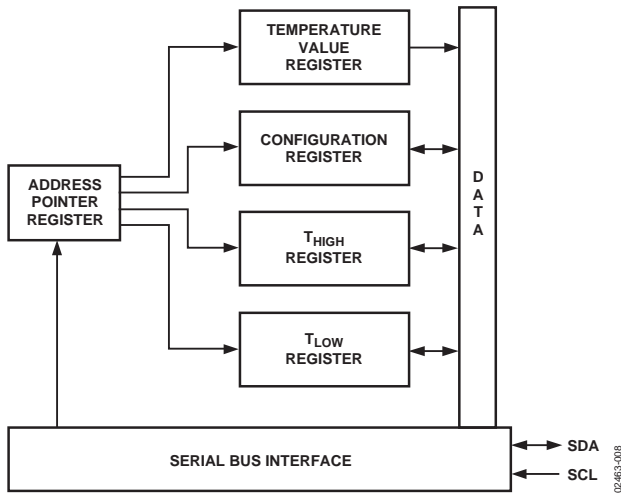

Figure 8. AD7414 Register Structure

The AD7415 has three internal registers, as shown in Figure 9. Two are data registers, and one is an address pointer register.

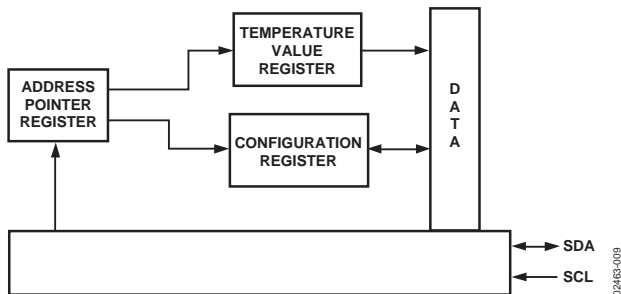

Figure 9. AD7415 Register Structure

Each data register has an address pointed to by the address pointer register when communicating with it. The temperature value register is the only data register that is read-only.

ADDRESS POINTER REGISTER

The address pointer register is an 8-bit register that stores an address that points to one of the four data registers of the AD7414 and one of the two data registers of the AD7415. The first byte of every serial write operation to the AD7414/AD7415 is the address of one of the data registers, which is stored in the address pointer register and selects the data register to which subsequent data bytes are written. Only the 2 LSBs of this register are used to select a data register.

Table 6. Address Pointer Register

P7	P6	P5	P4	P3	P2	P1	P0
0	0	0	0	0	0	Register Select	

Table 7. AD7414 Register Address

P1	P0	Register
0	0	Temperature value register (read-only)
0	1	Configuration register (read/write)
1	0	T _{HIGH} register (read/write)
1	1	T _{LOW} register (read/write)

Table 8. AD7415 Register Address

P1	P0	Registers
0	0	Temperature value register (read-only)
0	1	Configuration register (read/write)

Table 9. AD7414 Configuration Register

D7	D6	D5	D4	D3	D2	D1	D0
PD	FLTR	ALERT EN	ALERT POLARITY	ALERT RESET	ONE SHOT	TEST MODE	
0 ¹	1 ¹	0 ¹	0 ¹	0 ¹	0 ¹	0s ¹	

¹ Default settings at power-up.

CONFIGURATION REGISTER (ADDRESS 0x01)

The configuration register is an 8-bit read/write register that is used to set the operating modes of the AD7414/AD7415. In the AD7414, six of the MSBs are used (D7 to D2) to set the operating modes (see Table 10). D0 and D1 are used for factory settings and must have zeros written to them during normal operation.

Table 10. AD7414 Configuration Register Settings

D7	Full power-down if = 1.
D6	Bypass SDA and SCL filtering if = 0.
D5	Disable ALERT if = 1.
D4	ALERT is active low if D4 = 0, ALERT is active high if D4 = 1.
D3	Reset the ALERT pin if set to 1. The next temperature conversion has the ability to activate the ALERT function. The bit status is not stored; thus this bit is 0 if read.
D2	Initiate a one shot temperature conversion if set to 1. The bit status is not stored; thus this bit is 0 if read.

Table 11. AD7415 Configuration Register

D7	D6	D5	D4	D3	D2	D1	D0
PD	FLTR	TEST MODE			ONE SHOT	TEST MODE	
0 ¹	1 ¹	0s ¹			0s ¹	0s ¹	

¹ Default settings at power-up.

AD7414/AD7415

In the AD7415, only three of the bits are used (D7, D6, and D2) to set the operating modes (see Table 12). D0, D1, and D3 to D5 are used for factory settings and must have zeros written to them during normal operation.

Table 12. AD7415 Configuration Register Settings

D7	Full power-down if = 1.
D6	Bypass SDA and SCL filtering if = 0.
D2	Initiate a one-shot temperature conversion if set to 1. The bit status is not stored; thus this bit is 0 if read.

If the AD7414/AD7415 are in power-down mode (D7 = 1), a temperature conversion can still be initiated by the one-shot operation. This involves a write operation to the configuration register and setting the one-shot bit to 1 (D2 = 1), which causes the AD7414/AD7415 to power up, perform a single conversion, and power down again. This is a very power efficient mode.

TEMPERATURE VALUE REGISTER (ADDRESS 0x00)

The temperature value register is a 10-bit, read-only register that stores the temperature reading from the ADC in twos complement format. Two reads are necessary to read data from this register. Table 13 shows the contents of the first byte to be read, while Table 14 and Table 15 show the contents of the second byte to be read from the AD7414 and AD7415, respectively. In Table 14, D3 to D5 of the second byte are used as flag bits and are obtained from other internal registers. They function as follows:

ALERT_Flag: The state of this bit is the same as that of the ALERT pin.

T_{HIGH}_Flag: This flag is set to 1 when the temperature measured goes above the T_{HIGH} limit. It is reset when the second temperature byte (Table 14) is read. If the temperature is still greater than the T_{HIGH} limit after the read operation, the flag is again.

T_{LOW}_Flag: This flag is set to 1 when the temperature measured goes below the T_{LOW} limit. It is reset when the second temperature byte (Table 14) is read. If the temperature is still less than the T_{LOW} limit after the read operation, the flag is set again.

The full theoretical span of the ADC is 255°C, but in practice the temperature measurement range is limited to the operating range of the device, -40°C to +125°C for the A grade.

Table 13. Temperature Value Register (First Read)

D15	D14	D13	D12	D11	D10	D9	D8
MSB	B8	B7	B6	B5	B4	B3	B2

Table 14. AD7414 Temperature Value Register (Second Read)

D7	D6	D5	D4	D3	D2	D1	D0
B1	LSB	ALERT_Flag	T _{HIGH} _Flag	T _{LOW} _Flag	0	0	0

Table 15. AD7415 Temperature Value Register (Second Read)

D7	D6	D5	D4	D3	D2	D1	D0
B1	LSB	N/A	N/A	N/A	N/A	N/A	N/A

AD7414 T_{HIGH} REGISTER (ADDRESS 0x02)

The T_{HIGH} register (see Table 16) is an 8-bit, read/write register that stores the upper limit that activates the ALERT output. Therefore, if the value in the temperature value register is greater than the value in the T_{HIGH} register, the ALERT pin is activated (that is, if ALERT is enabled in the configuration register). Because it is an 8-bit register, the temperature resolution is 1°C.

Table 16. T_{HIGH} Register

D7	D6	D5	D4	D3	D2	D1	D0
MSB	B6	B5	B4	B3	B2	B1	B0

AD7414 T_{LOW} REGISTER (ADDRESS 0x03)

The T_{LOW} register (see Table 17) is an 8-bit read/write register that stores the lower limit that deactivates the ALERT output. Therefore, if the value in the temperature value register is less than the value in the T_{LOW} register, the ALERT pin is deactivated (that is, if ALERT is enabled in the configuration register).

Because it is an 8-bit register, the temperature resolution is 1°C.

Table 17. T_{LOW} Register

D7	D6	D5	D4	D3	D2	D1	D0
MSB	B6	B5	B4	B3	B2	B1	B0

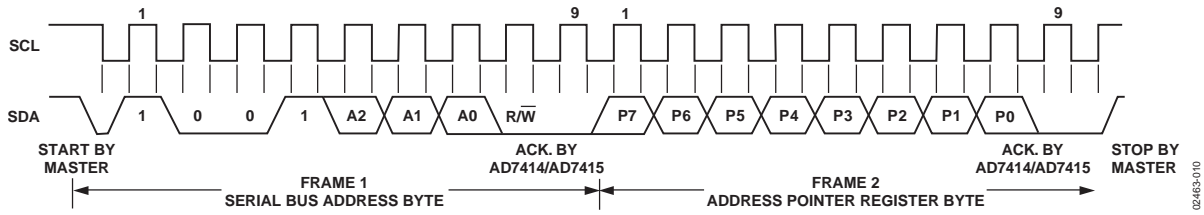

Figure 10. Writing to the Address Pointer Register to Select a Register for a Subsequent Read Operation

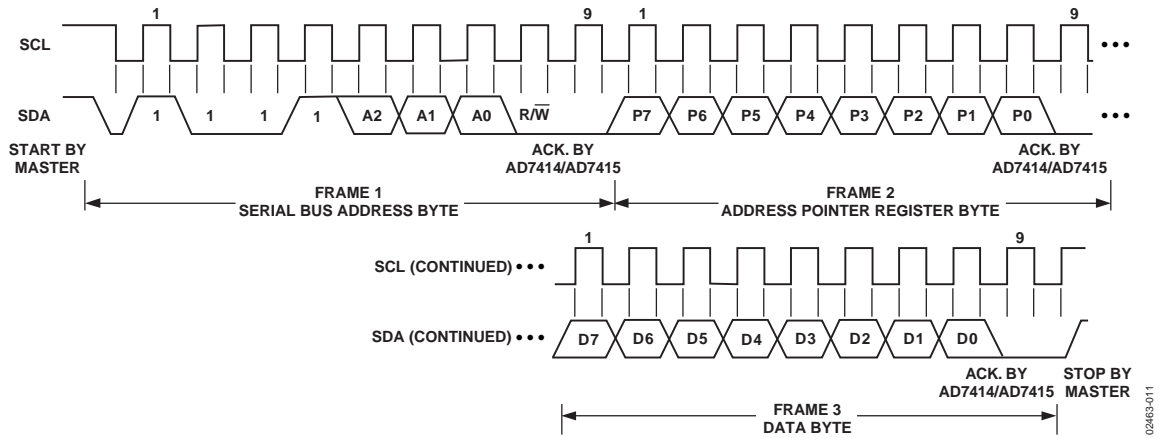

Figure 11. Writing to the Address Pointer Register Followed by a Single Byte of Data to the Selected Register

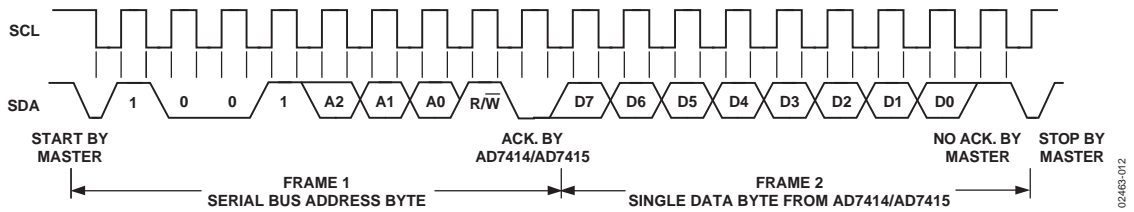

Figure 12. Reading a Single Byte of Data from a Selected Register

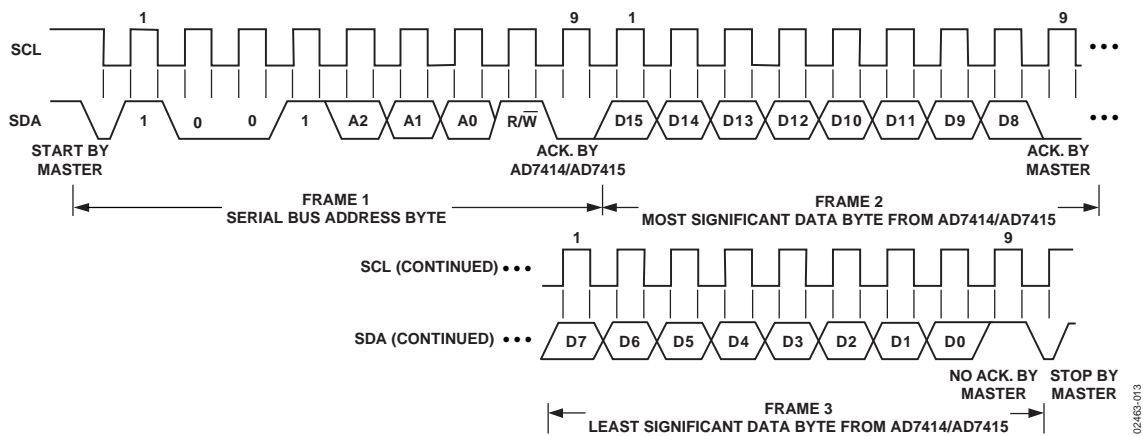

Figure 13. Reading Two Bytes of Data from the Temperature Value Register

SERIAL INTERFACE

Control of the AD7414/AD7415 is carried out via the I²C-compatible serial bus. The AD7414/AD7415 are connected to this bus as slave device, under the control of a master device, such as the processor.

SERIAL BUS ADDRESS

Like all I²C-compatible devices, the AD7414/AD7415 have a 7-bit serial address. The four MSBs of this address for the AD7414/AD7415 are set to 1001. The AD7414/AD7415 are available in four versions: AD7414/AD7415-0, AD7414/AD7415-1, AD7414-2, and AD7414-3. The first two versions have three different I²C addresses available, which are selected by either tying the AS pin to GND, to V_{DD}, or letting the pin float (see Table 4). By giving different addresses for the four versions, up to eight AD7414s or six AD7415s can be connected to a single serial bus, or the addresses can be set to avoid conflicts with other devices on the bus.

The serial bus protocol operates as follows.

The master initiates data transfer by establishing a START condition, defined as a high-to-low transition on the serial data line SDA, while the serial clock line SCL remains high. This indicates that an address/data stream follows. All slave peripherals connected to the serial bus respond to the START condition and shift in the next eight bits, consisting of a 7-bit address (MSB first) plus an R/ \overline{W} bit, which determines the direction of the data transfer and whether data is written to or read from the slave device.

The peripheral whose address corresponds to the transmitted address responds by pulling the data line low during the low period before the ninth clock pulse, known as the acknowledge bit. All other devices on the bus remain idle while the selected device waits for data to be read from or written to it. If the R/ \overline{W} bit is 0, the master writes to the slave device. If the R/ \overline{W} bit is 1, the master reads from the slave device.

Data is sent over the serial bus in sequences of nine clock pulses, eight bits of data followed by an acknowledge bit from the receiver of data. Transitions on the data line must occur during the low period of the clock signal and remain stable during the high period, because a low-to-high transition when the clock is high may be interpreted as a STOP signal.

When all data bytes have been read or written, stop conditions are established. In WRITE mode, the master pulls the data line high during the 10th clock pulse to assert a STOP condition. In READ mode, the master device pulls the data line high during the low period before the ninth clock pulse. This is known as No Acknowledge. The master then takes the data line low during the low period before the 10th clock pulse, then high during the 10th clock pulse to assert a STOP condition.

Any number of bytes of data may be transferred over the serial bus in one operation, but it is not possible to mix read and write in one operation. The type of operation is determined at the beginning and cannot then be changed without starting a new operation.

WRITE MODE

Depending on the register being written to, there are two different writes for the AD7414/AD7415.

Writing to the Address Pointer Register for a Subsequent Read

In order to read data from a particular register, the address pointer register must contain the address of that register. If it does not, the correct address must be written to the address pointer register by performing a single-byte write operation, as shown in Figure 10. The write operation consists of the serial bus address followed by the address pointer byte. No data is written to any of the data registers. A read operation is then performed to read the register.

Writing a Single Byte of Data to the Configuration Register, T_{HIGH} Register, or T_{LOW} Register

All three registers are 8-bit registers, so only one byte of data can be written to each register. Writing a single byte of data to one of these registers consists of the serial bus address, the data register address written to the address pointer register, followed by the data byte written to the selected data register. This is illustrated in Figure 11.

READ MODE

Reading data from the AD7414/AD7415 is a 1- or 2-byte operation. Reading back the contents of the configuration register, the T_{HIGH} register, or the T_{LOW} register is a single-byte read operation, as shown in Figure 12. The register address was previously set up by a single-byte write operation to the address pointer register. Once the register address has been set up, any number of reads can subsequently be performed from that register without having to write to the address pointer register again. To read from another register, the address pointer register has to be written to again to set up the relevant register address.

Reading data from the temperature value register is a 2-byte operation, as shown in Figure 13. The same rules apply for a 2-byte read as a 1-byte read.

SMBUS ALERT

The AD7414 ALERT output is an SMBus interrupt line for devices that want to trade their ability to master for an extra pin. The AD7414 is a slave-only device and uses the SMBus ALERT to signal to the host device that it wants to talk. The SMBus ALERT on the AD7414 is used as an overtemperature indicator.

The ALERT pin has an open-drain configuration that allows the ALERT outputs of several AD7414s to be wire-AND'ed together when the ALERT pin is active low. Use D4 of the configuration register to set the active polarity of the ALERT output. The power-up default is active low. The ALERT function can be disabled or enabled by setting D5 of the configuration register to 1 or 0, respectively.

The host device can process the ALERT interrupt and simultaneously access all SMBus ALERT devices through the alert response address. Only the device that pulled the ALERT low acknowledges the Alert Response Address (ARA). If more than one device pulls the ALERT pin low, the highest priority (lowest address) device wins communication rights via standard I²C arbitration during the slave address transfer.

The ALERT output becomes active when the value in the temperature value register exceeds the value in the T_{HIGH} register. It is reset when a write operation to the configuration register sets D3 to 1 or when the temperature falls below the value stored in the T_{LOW} register.

The ALERT output requires an external pull-up resistor. This can be connected to a voltage different from V_{DD}, provided the maximum voltage rating of the ALERT output pin is not exceeded. The value of the pull-up resistor depends on the application, but it should be as large as possible to avoid excessive sink currents at the ALERT output, which can heat the chip and affect the temperature reading.

POWER-ON DEFAULTS

The AD7414/AD7415 always power up with these defaults:

Address pointer register pointing to the temperature value register.

T_{HIGH} register loaded with 7Fh.

T_{LOW} register loaded with 80h.

Configuration register loaded with 40h.

Note that the AD7415 does not have any T_{HIGH} or T_{LOW} registers.

OPERATING MODES

Mode 1

This is the power-on default mode of the AD7414/AD7415. In this mode, the AD7414/AD7415 does a temperature conversion every 800 ms and then partially powers down until the next conversion occurs.

If a one-shot operation (setting D2 of the configuration register to a 1) is performed between automatic conversions, a conversion is initiated right after the write operation. After this conversion, the part returns to performing a conversion every 800 ms.

Depending on where a serial port access occurs during a conversion, that conversion might be aborted. If the conversion is completed before the part recognizes a serial port access, the temperature register is updated with the new conversion. If the conversion is completed after the part recognizes a serial port access, the internal logic prevents the temperature register from being updated, because corrupt data could be read.

A temperature conversion can start anytime during a serial port access (other than a one-shot operation), but the result of that conversion is loaded into the temperature register only if the serial port access is not active at the end of the conversion.

Mode 2

The only other mode in which the AD7414/AD7415 operates is the full power-down mode. This mode is usually used when temperature measurements are required at a very slow rate. The power consumption of the part can be greatly reduced in this mode by writing to the part to go to a full power-down. Full power-down is initiated right after D7 of the configuration register is set to 1.

When a temperature measurement is required, a write operation can be performed to power up the part and put it into one-shot mode (setting D2 of the configuration register to a 1). The power-up takes approximately 4 μs. The part then performs a conversion and is returned to full power-down. The temperature value can be read in the full power-down mode, because the serial interface is still powered up.

AD7414/AD7415

POWER VS. THROUGHPUT

The two modes of operation for the AD7414/AD7415 produce different power vs. throughput performances. Mode 2 is the sleep mode of the part, and it achieves the optimum power performance.

Mode 1

In this mode, continuous conversions are performed at a rate of approximately one every 800 ms. Figure 14 shows the times and currents involved with this mode of operation for a 5 V supply. At 5 V, the current consumption for the part when converting is 1.1 mA typically, and the quiescent current is 188 μ A typically. The conversion time of 25 μ s plus power-up time of typically 4 μ s contributes 199.3 nW to the overall power dissipation in the following way:

$$(29 \mu\text{s}/800 \text{ ms}) \times (5 \times 1.1 \text{ mA}) = 199.3 \text{ nW}$$

The contribution to the total power dissipated by the remaining time is 939.96 μ W.

$$(799.97 \text{ ms}/800 \text{ ms}) \times (5 \times 1.1 \mu\text{A}) = 199.3 \mu\text{W}$$

Thus the total power dissipated during each cycle is

$$199.3 \text{ nW} + 939.96 \mu\text{W} = 940.16 \mu\text{W}$$

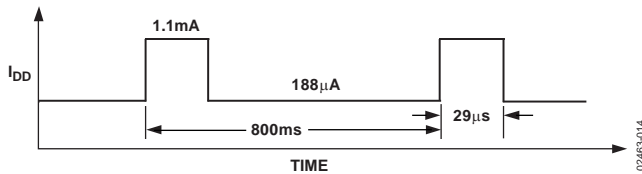

Figure 14. Mode 1 Power Dissipation

Mode 2

In this mode, the part is totally powered down. All circuitry except the serial interface is switched off. The most power efficient way of operating in this mode is to use the one-shot method. Write to the configuration register and set the one-shot bit to a 1. The part powers up in approximately 4 μ s and then performs a conversion. Once the conversion is finished, the device powers down again until the PD bit in the configuration register is set to 0 or the one-shot bit is set to 1. Figure 15 shows the same timing as Figure 14 in mode 1; a one-shot is initiated every 800 ms. If we take the voltage supply to be 5 V, we can work out the power dissipation in the following way. The current consumption for the part when converting is 1.1 mA typically, and the quiescent current is 800 nA typically. The conversion time of 25 μ s plus the power-up time of typically 4 μ s contributes 199.3 nW to the overall power dissipation in the following way:

$$(29 \mu\text{s}/800 \text{ ms}) \times (5 \text{ V} \times 1.1 \text{ mA}) = 199.3 \text{ nW}$$

The contribution to the total power dissipated by the remaining time is 3.9 μ W.

$$(799.971 \text{ ms}/800 \text{ ms}) \times (5 \text{ V} \times 800 \text{ nA}) = 3.9 \mu\text{W}$$

Thus the total power dissipated during each cycle is:

$$199.3 \text{ nW} + 3.9 \mu\text{W} = 940.16 \mu\text{W}$$

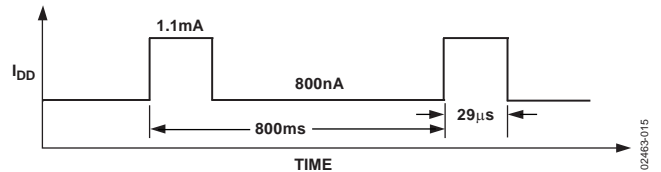

Figure 15. Mode 2 Power Dissipation

MOUNTING THE AD7414/AD7415

The AD7414/AD7415 can be used for surface or air temperature sensing applications. If the device is cemented to a surface with thermally conductive adhesive, the die temperature is within about 0.1°C of the surface temperature, due to the device's low power consumption. Care should be taken to insulate the back and leads of the device from the air if the ambient air temperature is different from the surface temperature being measured.

The ground pin provides the best thermal path to the die, so the temperature of the die is close to that of the printed circuit ground track. Care should be taken to ensure that this is in good thermal contact with the surface being measured.

As with any IC, the AD7414/AD7415 and their associated wiring and circuits must be kept free from moisture to prevent leakage and corrosion, particularly in cold conditions where condensation is more likely to occur. Water-resistant varnishes and conformal coatings can be used for protection. The small size of the AD7414/AD7415 packages allows them to be mounted inside sealed metal probes, which provide a safe environment for the devices.

SUPPLY DECOUPLING

The AD7414/AD7415 should at least be decoupled with a 0.1 μ F ceramic capacitor between V_{DD} and GND. This is particularly important if the AD7414/AD7415 are mounted remote from the power supply.

TEMPERATURE ACCURACY VS. SUPPLY

The temperature accuracy specifications are guaranteed for voltage supplies of 3 V and 5.5 V only. Figure 16 gives the typical performance characteristics of a large sample of parts over the full voltage range of 2.7 V to 5.5 V. Figure 17 gives the typical performance characteristics of one part over the full voltage range of 2.7 V to 5.5 V.

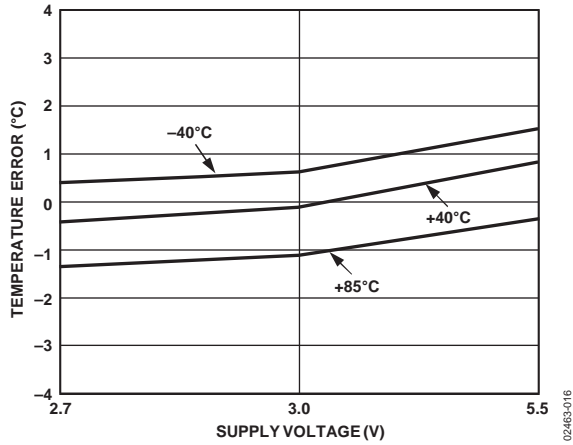

Figure 16. Typical Temperature Error vs. Supply for Large Sample of Parts

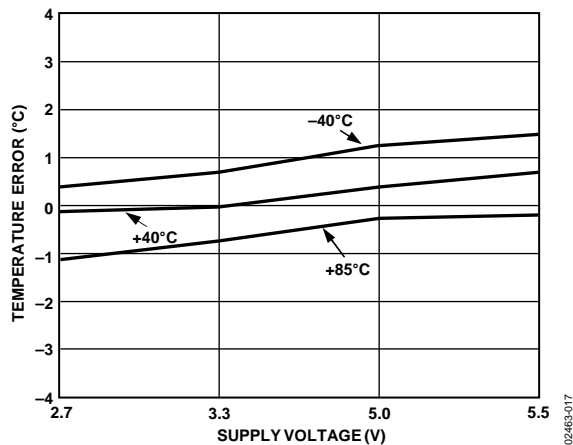

Figure 17. Typical Temperature Error vs. Supply for One Part

TYPICAL TEMPERATURE ERROR GRAPH

Figure 18 shows the typical temperature error plots for one device with V_{DD} at 3.3 V and at 5.5 V.

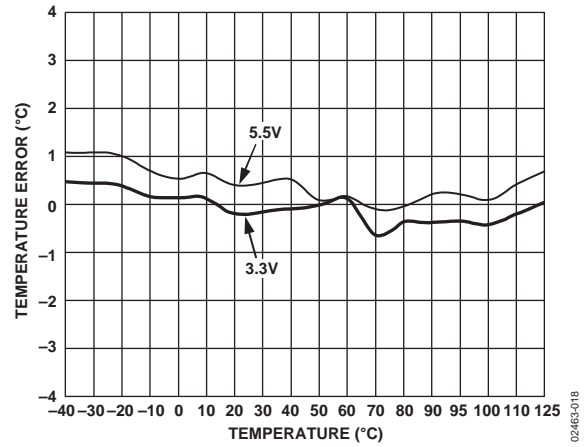

Figure 18. Typical Temperature Error @ 3.3 V and 5.5 V

Figure 19 shows a histogram of the temperature error at ambient temperature (40°C) over approximately 6,000 units. Figure 19 shows that over 70% of the AD7414/AD7415 devices tested have a temperature error within $\pm 0.3^\circ\text{C}$.

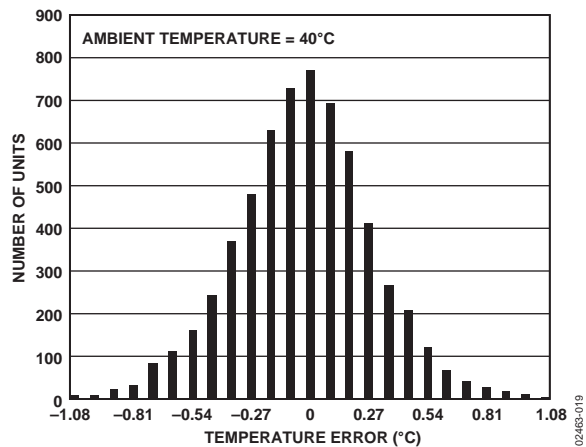
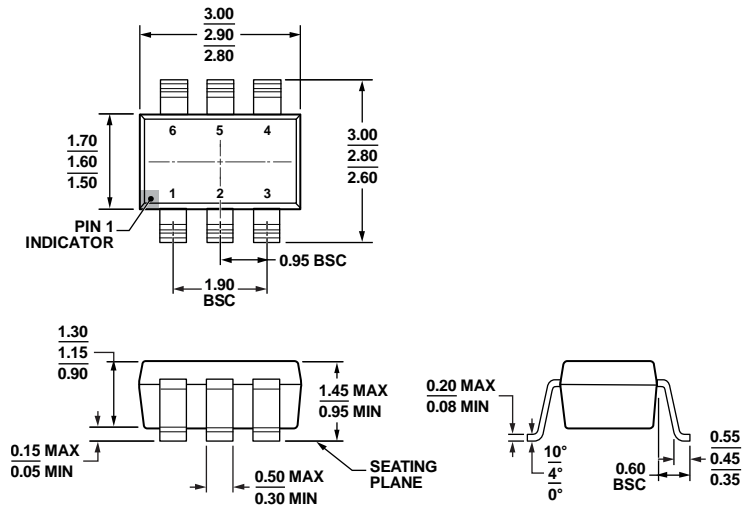

Figure 19. Ambient Temperature Error @ 3 V

OUTLINE DIMENSIONS



COMPLIANT TO JEDEC STANDARDS MO-178-AB

Figure 20. 6-Lead Small Outline Transistor Package [SOT-23] (RJ-6)
Dimensions shown in millimeters

121608-A

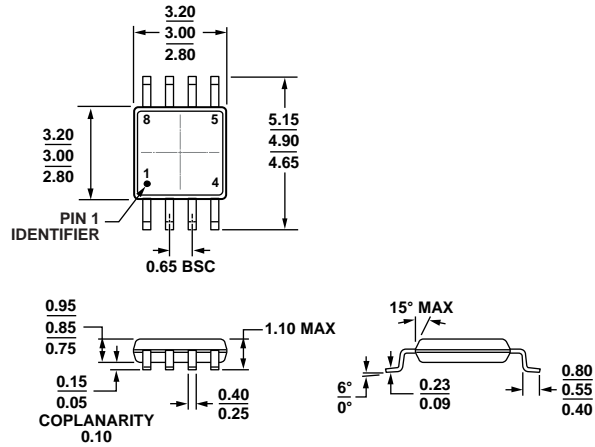

COMPLIANT TO JEDEC STANDARDS MO-187-AA

Figure 21. 8-Lead Mini Small Outline Package [MSOP] (RM-8)
Dimensions shown in millimeters

10-07-2009-B

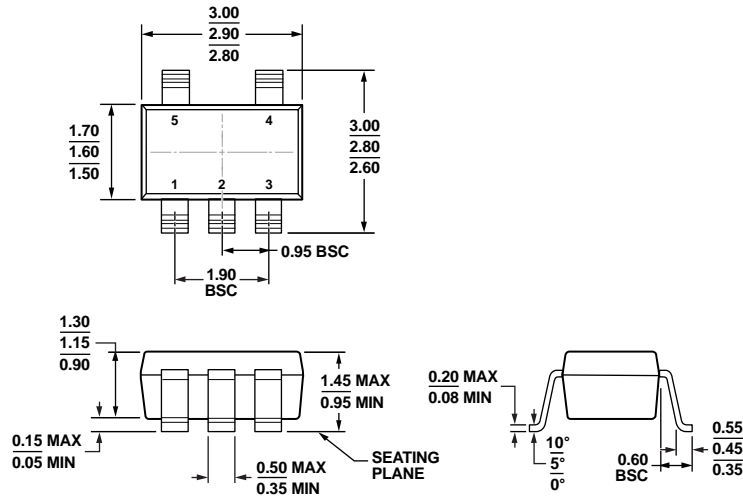

COMPLIANT TO JEDEC STANDARDS MO-178-AA

Figure 22. 5-Lead Small Outline Transistor Package [SOT-23] (RJ-5)
Dimensions shown in millimeters

11-01-2010-A

AD7414/AD7415

ORDERING GUIDE

Model ¹	Temperature Range	Typ Temperature Error @ 3 V	Package Option	Package Description	Branding	Ordering Quantity
AD7414ARTZ-0REEL7	-40°C to +125°C	±2°C	RJ-6	6-Lead SOT-23	#CHA	3,000
AD7414ARTZ-0REEL	-40°C to +125°C	±2°C	RJ-6	6-Lead SOT-23	#CHA	10,000
AD7414ARTZ-0500RL7	-40°C to +125°C	±2°C	RJ-6	6-Lead SOT-23	#CHA	500
AD7414ARMZ-0REEL7	-40°C to +125°C	±2°C	RM-8	8-Lead MSOP	TOL	3,000
AD7414ARMZ-0REEL	-40°C to +125°C	±2°C	RM-8	8-Lead MSOP	TOL	10,000
AD7414ARMZ-0	-40°C to +125°C	±2°C	RM-8	8-Lead MSOP	TOL	50
AD7414ARTZ-1REEL7	-40°C to +125°C	±2°C	RJ-6	6-Lead SOT-23	TOH	3,000
AD7414ARTZ-1REEL	-40°C to +125°C	±2°C	RJ-6	6-Lead SOT-23	TOH	10,000
AD7414ARTZ-1500RL7	-40°C to +125°C	±2°C	RJ-6	6-Lead SOT-23	TOH	500
AD7414ARTZ-2REEL7	-40°C to +125°C	±2°C	RJ-6	6-Lead SOT-23	TOJ	3,000
AD7414ARTZ-2REEL	-40°C to +125°C	±2°C	RJ-6	6-Lead SOT-23	TOJ	10,000
AD7414ARTZ-3REEL7	-40°C to +125°C	±2°C	RJ-6	6-Lead SOT-23	TOK	3,000
AD7414ARTZ-3REEL	-40°C to +125°C	±2°C	RJ-6	6-Lead SOT-23	TOK	10,000
AD7415ARTZ-0REEL7	-40°C to +125°C	±2°C	RJ-5	5-Lead SOT-23	#CGA	3,000
AD7415ARTZ-0REEL	-40°C to +125°C	±2°C	RJ-5	5-Lead SOT-23	#CGA	10,000
AD7415ARTZ-0500RL7	-40°C to +125°C	±2°C	RJ-5	5-Lead SOT-23	#CGA	500
AD7415ARTZ-1REEL7	-40°C to +125°C	±2°C	RJ-5	5-Lead SOT-23	#CGB	3,000
AD7415ARTZ-1REEL	-40°C to +125°C	±2°C	RJ-5	5-Lead SOT-23	#CGB	10,000
AD7415ARTZ-1500RL7	-40°C to +125°C	±2°C	RJ-5	5-Lead SOT-23	#CGB	500
EVAL-AD7414/15EBZ				Evaluation Board		

¹ Z = RoHS Compliant Part.

NOTES

NOTES

I²C refers to a communications protocol originally developed by Philips Semiconductors (now NXP Semiconductors).

Looking for pricing, stock, or lifecycle information?

Click below to explore more details on WIN SOURCE:

 [View AD7414ARTZ-1REEL7 on WIN SOURCE](#)

 [Analog Devices Inc. Information](#)

Optimize Your Supply Chain with WIN SOURCE Solutions

-  Global Sourcing Solution
-  Obsolete Management
-  Cost Control Management
-  Shortage Management
-  Alternative Solution
-  Excess Inventory Management