



**THE DATASHEET OF
TXS0101DBVTG4**



TXS0101 1-Bit Bidirectional Level-Shifting, Voltage-Level Translator With Auto-Direction-Sensing for Open-Drain and Push-Pull Applications

1 Features

- Latch-Up Performance Exceeds 100 mA Per JESD 78, Class II
- ESD Protection Exceeds JESD 22
 - A Port
 - 2500 V Human-Body Model (A114-B)
 - 200 V Machine Model (A115-A)
 - 1500 V Charged-Device Model (C101)
 - B Port
 - 8 kV Human-Body Model (A114-B)
 - 200 V Machine Model (A115-A)
 - 1500 V Charged-Device Model (C101)
- No Direction-Control Signal Needed
- Maximum Data Rates
 - 24 Mbps (Push Pull)
 - 2 Mbps (Open Drain)
- Available in the Texas Instruments NanoFree™ Package
- 1.65 V to 3.6 V on A port and 2.3 V to 5.5 V on B port ($V_{CCA} \leq V_{CCB}$)
- V_{CC} Isolation Feature – If Either V_{CC} Input Is at GND, Both Ports Are in the High-Impedance State
- No Power-Supply Sequencing Required – Either V_{CCA} or V_{CCB} Can be Ramped First
- I_{off} Supports Partial-Power-Down Mode Operation

2 Applications

- Handsets
- Smartphones
- Tablets
- Desktop PCs

3 Description

This one-bit non-inverting translator uses two separate configurable power-supply rails. The A port is designed to track V_{CCA} . V_{CCA} accepts any supply voltage from 1.65 V to 3.6 V. The B port is designed to track V_{CCB} . V_{CCA} must be less than or equal to V_{CCB} . V_{CCB} accepts any supply voltage from 2.3 V to 5.5 V. This allows for low voltage bidirectional translation between any of the 1.8 V, 2.5 V, 3.3 V, and 5 V voltage nodes.

When the output-enable (OE) input is low, all outputs are placed in the high-impedance state.

To ensure the high-impedance state during power up or power down, OE should be tied to GND through a pull-down resistor; the minimum value of the resistor is determined by the current-sourcing capability of the driver.

Device Information⁽¹⁾

PART NUMBER	PACKAGE	BODY SIZE (NOM)
TXS0101DBV	SOT-23 (6)	2.90 mm x 1.60 mm
TXS0101DCK	SC70 (6)	2.00 mm x 1.25 mm
TXS0101DRL	SOT-5X3 (6)	1.90 mm x 1.60 mm
TXS0101YZP	DSBGA (6)	0.89 mm x 1.39 mm

(1) For all available packages, see the orderable addendum at the end of the data sheet.

Typical Operating Circuit

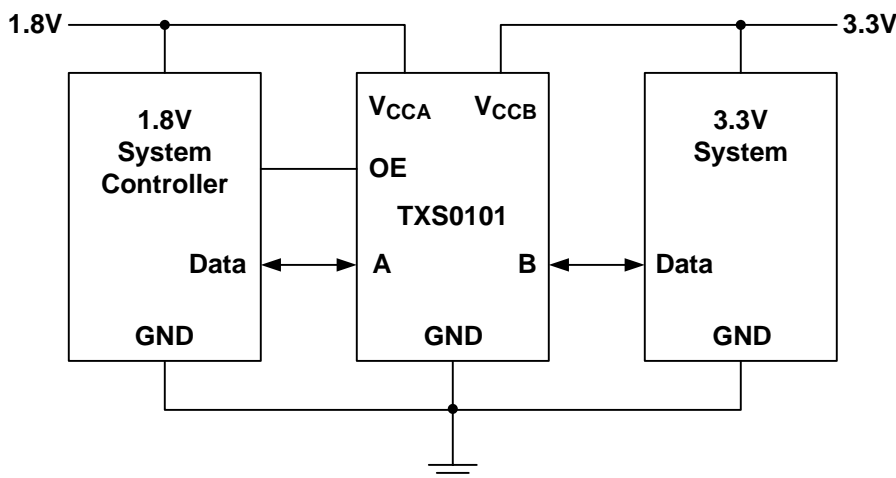

Table of Contents

1 Features	1	8 Detailed Description	16
2 Applications	1	8.1 Overview	16
3 Description	1	8.2 Functional Block Diagram	16
4 Revision History	2	8.3 Feature Description	17
5 Pin Configuration and Functions	3	8.4 Device Functional Modes	17
6 Specifications	4	9 Application and Implementation	18
6.1 Absolute Maximum Ratings	4	9.1 Application Information	18
6.2 ESD Ratings	4	9.2 Typical Application	18
6.3 Recommended Operating Conditions	5	10 Power Supply Recommendations	20
6.4 Thermal Information	5	11 Layout	20
6.5 Electrical Characteristics	6	11.1 Layout Guidelines	20
6.6 Timing Requirements: $V_{CCA} = 1.8\text{ V} \pm 0.15\text{ V}$	7	11.2 Layout Example	20
6.7 Timing Requirements: $V_{CCA} = 2.5\text{ V} \pm 0.2\text{ V}$	7	12 Device and Documentation Support	21
6.8 Timing Requirements: $3.3\text{ V} \pm 0.3\text{ V}$	7	12.1 Device Support	21
6.9 Switching Characteristics: $V_{CCA} = 1.8\text{ V} \pm 0.15\text{ V}$	8	12.2 Receiving Notification of Documentation Updates	21
6.10 Switching Characteristics: $V_{CCA} = 2.5\text{ V} \pm 0.2\text{ V}$	9	12.3 Community Resources	21
6.11 Switching Characteristics: $V_{CCA} = 3.3\text{ V} \pm 0.3\text{ V}$	12	12.4 Trademarks	21
6.12 Typical Characteristics	13	12.5 Electrostatic Discharge Caution	21
7 Parameter Measurement Information	14	12.6 Glossary	21
7.1 Load Circuits	14	13 Mechanical, Packaging, and Orderable Information	21
7.2 Voltage Waveforms	15		

4 Revision History

NOTE: Page numbers for previous revisions may differ from page numbers in the current version.

Changes from Revision C (December 2015) to Revision D	Page
• Changed YZP package pinout diagram with new image and added YZP pin assignments in <i>Pin Functions</i> table	3
• Added Junction temperature, T_j in <i>Absolute Maximum Ratings</i> table	4
• Added <i>Receiving Notification of Documentation Updates</i> section	21

Changes from Revision B (January 2009) to Revision C	Page
• Added <i>ESD Ratings</i> table, <i>Feature Description</i> section, <i>Device Functional Modes</i> , <i>Application and Implementation</i> section, <i>Power Supply Recommendations</i> section, <i>Layout</i> section, <i>Device and Documentation Support</i> section, and <i>Mechanical, Packaging, and Orderable Information</i> section	1

5 Pin Configuration and Functions

**DBV, DCK, and DRL Package
6-Pin SOT-23, SC70, and SOT
Top View**

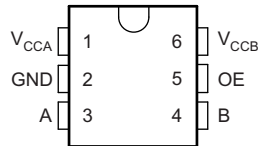

**YZP Package
6-Pin DSBGA
Bottom View**

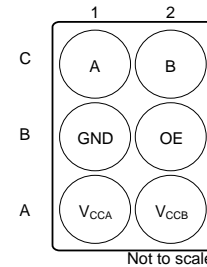

Pin Functions

NAME	PIN		TYPE	DESCRIPTION
	DBV, DCK, DRL	YZP		
A	3	C1	I/O	Input/output A. Referenced to V_{CCA}
B	4	C2	I/O	Input/output B. Referenced to V_{CCB}
GND	2	B1	G	Ground
OE	5	B2	I	Output enable. Pull OE low to place all outputs in 3-state mode. Referenced to V_{CCA} .
V_{CCA}	1	A1	I	A-port supply voltage. $1.65\text{ V} \leq V_{CCA} \leq 3.6\text{ V}$ and $V_{CCA} \leq V_{CCB}$
V_{CCB}	6	A2	I	B-port supply voltage. $2.3\text{ V} \leq V_{CCB} \leq 5.5\text{ V}$

6 Specifications

6.1 Absolute Maximum Ratings

over operating free-air temperature range (unless otherwise noted)⁽¹⁾

		MIN	MAX	UNIT	
V _{CCA}	Supply voltage	-0.5	4.6	V	
V _{CCB}	Supply voltage	-0.5	6.5	V	
V _I	Input voltage ⁽²⁾	A port	-0.5	4.6	V
		B port, OE	-0.5	6.5	
V _O	Voltage range applied to any output in the high-impedance or power-off state ⁽²⁾	A port	-0.5	4.6	V
		B port	-0.5	6.5	
V _O	Voltage range applied to any output in the high or low state ^{(2) (3)}	A port	-0.5	V _{CCA} + 0.5	V
		B port	-0.5	V _{CCB} + 0.5	
I _{IK}	Input clamp current	V _I < 0	-50	mA	
I _{OK}	Output clamp current	V _O < 0	-50	mA	
I _O	Continuous output current		±50	mA	
	Continuous current through V _{CCA} , V _{CCB} , or GND		±100	mA	
T _J	Junction temperature		150	°C	
T _{stg}	Storage temperature	-65	150	°C	

- (1) Stresses beyond those listed under *Absolute Maximum Ratings* may cause permanent damage to the device. These are stress ratings only, which do not imply functional operation of the device at these or any other conditions beyond those indicated under *Recommended Operating Conditions*. Exposure to absolute-maximum-rated conditions for extended periods may affect device reliability.
- (2) The input and output negative-voltage ratings may be exceeded if the input and output current ratings are observed.
- (3) The value of V_{CCA} and V_{CCB} are provided in the recommended operating conditions table.

6.2 ESD Ratings

		VALUE	UNIT
V _(ESD)	Electrostatic discharge	Human body model (HBM), per ANSI/ESDA/JEDEC JS-001, A Port ⁽¹⁾	±2500
		Human body model (HBM), per ANSI/ESDA/JEDEC JS-001, B Port ⁽¹⁾	±8000
		Charged device model (CDM), per JEDEC specification JESD22-C101, B Port ⁽²⁾	±1500
		Machine model (MM, A115-A), A Port	±200

- (1) JEDEC document JEP155 states that 500 V HBM allows safe manufacturing with a standard ESD control process.
- (2) JEDEC document JEP157 states that 250 V CDM allows safe manufacturing with a standard ESD control process.

6.3 Recommended Operating Conditions

See ⁽¹⁾ ⁽²⁾

		V_{CCA}	V_{CCB}	MIN	MAX	UNIT	
V_{CCA}	Supply voltage ⁽³⁾			1.65	3.6	V	
V_{CCB}				2.3	5.5		
V_{IH}	High-level input voltage	A-port I/Os	1.65 V to 1.95 V 2.3 V to 3.6 V	2.3 V to 5.5 V	$V_{CCI} - 0.2$	V_{CCI}	V
					$V_{CCI} - 0.4$	V_{CCI}	
		B-port I/Os	1.65 V to 3.6 V	2.3 V to 5.5 V	$V_{CCI} - 0.4$	V_{CCI}	
OE input	$V_{CCA} \times 0.65$	5.5					
V_{IL}	Low-level input voltage	A-port I/Os	1.65 V to 3.6 V	2.3 V to 5.5 V	0	0.15	V
		B-port I/Os			0	0.15	
		OE input			0	$V_{CCA} \times 0.35$	
$\Delta t/\Delta v$	Input transition rise or fall rate	A-port I/Os, push-pull driving	1.65 V to 3.6 V	2.3 V to 5.5 V	10		ns/V
		B-port I/Os, push-pull driving			10		
		Control Input			10		
T_A	Operating free-air temperature			-40	85	°C	

- (1) V_{CCI} is the supply associated with the input port.
(2) V_{CCO} is the supply associated with the output port.
(3) V_{CCA} must be less than or equal to V_{CCB} , and V_{CCA} must not exceed 3.6 V.

6.4 Thermal Information

THERMAL METRIC ⁽¹⁾	TXS0101				UNIT
	DBV (SOT-23)	DCK (SC70)	DRL (SOT)	DSBGA (YZP)	
	6 PINS	6 PINS	6 PINS	6 PINS	
$R_{\theta JA}$ Junction-to-ambient thermal resistance	223.9	266.9	204.2	107.8	°C/W
$R_{\theta JC(top)}$ Junction-to-case (top) thermal resistance	185.6	80.4	76.4	1.6	°C/W
$R_{\theta JB}$ Junction-to-board thermal resistance	63.5	99.1	38.7	10.8	°C/W
Ψ_{JT} Junction-to-top characterization parameter	63.5	1.5	3.4	3.1	°C/W
Ψ_{JB} Junction-to-board characterization parameter	71.8	98.3	38.5	10.8	°C/W

- (1) For more information about traditional and new thermal metrics, see the *Semiconductor and IC Package Thermal Metrics* application report, [SPRA953](#).

6.5 Electrical Characteristics

 over recommended operating free-air temperature range of -40°C to 85°C (unless otherwise noted) See⁽¹⁾ ⁽²⁾ ⁽³⁾

PARAMETER		TEST CONDITIONS	V_{CCA}	V_{CCB}	MIN	TYP	MAX	UNIT
V_{OHA}		$I_{OH} = -20\ \mu\text{A}$, $V_{IB} \geq V_{CCB} - 0.4\ \text{V}$	1.65 V to 3.6 V	2.3 V to 5.5 V	$V_{CCA} \times 0.67$			V
V_{OLA}		$I_{OL} = 1\ \text{mA}$, $V_{IB} \leq 0.15\ \text{V}$	1.65 V to 3.6 V	2.3 V to 5.5 V			0.4	V
V_{OHB}		$I_{OH} = -20\ \mu\text{A}$, $V_{IA} \geq V_{CCA} - 0.2\ \text{V}$	1.65 V to 3.6 V	2.3 V to 5.5 V	$V_{CCB} \times 0.67$			V
V_{OLB}		$I_{OL} = 1\ \text{mA}$, $V_{IA} \leq 0.15\ \text{V}$	1.65 V to 3.6 V	2.3 V to 5.5 V			0.4	V
I_i	OE	$T_A = 25^{\circ}\text{C}$	1.65 V to 3.6 V	1.65 V to 5.5 V			± 1	μA
		-40°C to 85°C					± 2	
I_{off}	A port	$T_A = 25^{\circ}\text{C}$	0 V	0 to 5.5 V			± 1	μA
		-40°C to 85°C					± 2	
	B port	$T_A = 25^{\circ}\text{C}$	0 to 3.6 V	0 V			± 1	μA
		-40°C to 85°C					± 2	
I_{OZ}	A or B port	$T_A = 25^{\circ}\text{C}$	1.65 V to 3.6 V	2.3 V to 5.5 V			± 1	μA
		-40°C to 85°C					± 2	
I_{CCA}	$V_I = V_O = \text{open}$, $I_O = 0$		1.65 V to V_{CCB}	2.3 V to 5.5 V			2.4	μA
			3.6 V	0 V			2.2	
			0 V	5.5 V			-1	
I_{CCB}	$V_I = V_O = \text{open}$, $I_O = 0$		1.65 V to V_{CCB}	2.3 V to 5.5 V			12	μA
			3.6 V	0 V			-1	
			0 V	5.5 V			1	
$I_{CCA} + I_{CCB}$		$V_I = V_{CCI}$, $I_O = 0$	1.65 V to V_{CCB}	2.3 V to 5.5 V			14.4	μA
C_i	OE	$T_A = 25^{\circ}\text{C}$	3.3 V	3.3 V			2.5	pF
		-40°C to 85°C					3.5	
C_{io}	A port	$T_A = 25^{\circ}\text{C}$	3.3 V	3.3 V			5	pF
		-40°C to 85°C					6	
	B port	$T_A = 25^{\circ}\text{C}$					6	
		-40°C to 85°C					7.5	

- (1) V_{CCI} is the V_{CC} associated with the input port.
- (2) V_{CCO} is the V_{CC} associated with the output port.
- (3) V_{CCA} must be less than or equal to V_{CCB} , and V_{CCA} must not exceed 3.6 V.

6.6 Timing Requirements: $V_{CCA} = 1.8\text{ V} \pm 0.15\text{ V}$

			MIN	NOM	MAX	UNIT
Data rate	Push-pull driving, Figure 4	Data inputs	$V_{CCB} = 2.5\text{ V}, \pm 0.2\text{ V}$			21
			$V_{CCB} = 3.3\text{ V}, \pm 0.3\text{ V}$			22
			$V_{CCB} = 5\text{ V}, \pm 0.5\text{ V}$			24
	Open-drain driving, Figure 5		$V_{CCB} = 2.5\text{ V}, \pm 0.2\text{ V}$			2
			$V_{CCB} = 3.3\text{ V}, \pm 0.3\text{ V}$			2
			$V_{CCB} = 5\text{ V}, \pm 0.5\text{ V}$			2
t_w Pulse duration Figure 7	Push-pull driving, Figure 4	Data inputs	$V_{CCB} = 2.5\text{ V}, \pm 0.2\text{ V}$		47	ns
			$V_{CCB} = 3.3\text{ V}, \pm 0.3\text{ V}$		45	
			$V_{CCB} = 5\text{ V}, \pm 0.5\text{ V}$		41	
	Open-drain driving, Figure 5		$V_{CCB} = 2.5\text{ V}, \pm 0.2\text{ V}$		500	
			$V_{CCB} = 3.3\text{ V}, \pm 0.3\text{ V}$		500	
			$V_{CCB} = 5\text{ V}, \pm 0.5\text{ V}$		500	

6.7 Timing Requirements $V_{CCA} = 2.5\text{ V} \pm 0.2\text{ V}$

			MIN	NOM	MAX	UNIT
Data rate	Push-pull driving, Figure 4	Data inputs	$V_{CCB} = 2.5\text{ V}, \pm 0.2\text{ V}$			20
			$V_{CCB} = 3.3\text{ V}, \pm 0.3\text{ V}$			22
			$V_{CCB} = 5\text{ V}, \pm 0.5\text{ V}$			24
	Open-drain driving, Figure 5		$V_{CCB} = 2.5\text{ V}, \pm 0.2\text{ V}$			2
			$V_{CCB} = 3.3\text{ V}, \pm 0.3\text{ V}$			2
			$V_{CCB} = 5\text{ V}, \pm 0.5\text{ V}$			1
t_w Pulse duration Figure 7	Push-pull driving, Figure 4	Data inputs	$V_{CCB} = 2.5\text{ V}, \pm 0.2\text{ V}$		50	ns
			$V_{CCB} = 3.3\text{ V}, \pm 0.3\text{ V}$		45	
			$V_{CCB} = 5\text{ V}, \pm 0.5\text{ V}$		41	
	Open-drain driving, Figure 5		$V_{CCB} = 2.5\text{ V}, \pm 0.2\text{ V}$		500	
			$V_{CCB} = 3.3\text{ V}, \pm 0.3\text{ V}$		500	
			$V_{CCB} = 5\text{ V}, \pm 0.5\text{ V}$		500	

6.8 Timing Requirements: $3.3\text{ V} \pm 0.3\text{ V}$

			MIN	NOM	MAX	UNIT
Data rate	Push-pull driving, Figure 4	Data inputs	$V_{CCB} = 3.3\text{ V}, \pm 0.3\text{ V}$			23
			$V_{CCB} = 5\text{ V}, \pm 0.5\text{ V}$			24
	Open-drain driving, Figure 5		$V_{CCB} = 3.3\text{ V}, \pm 0.3\text{ V}$			2
			$V_{CCB} = 5\text{ V}, \pm 0.5\text{ V}$			2
Pulse duration Figure 7	Push-pull driving, Figure 4	Data inputs	$V_{CCB} = 3.3\text{ V}, \pm 0.3\text{ V}$		43	ns
			$V_{CCB} = 5\text{ V}, \pm 0.5\text{ V}$		41	
	Open-drain driving, Figure 5		$V_{CCB} = 3.3\text{ V}, \pm 0.3\text{ V}$		500	
			$V_{CCB} = 5\text{ V}, \pm 0.5\text{ V}$		500	

6.9 Switching Characteristics: $V_{CCA} = 1.8 \text{ V} \pm 0.15 \text{ V}$

 over recommended operating free-air temperature range, $V_{CCA} = 2.5 \text{ V} \pm 0.2 \text{ V}$ (unless otherwise noted)

PARAMETER	FROM (INPUT)	TO (OUTPUT)	TEST CONDITIONS (DRIVING)		MIN	MAX	UNIT
t_{PHL} Figure 8	A	B	Push-pull, Figure 4	$V_{CCB} = 2.5 \text{ V} \pm 0.2 \text{ V}$		5.3	ns
				$V_{CCB} = 3.3 \text{ V} \pm 0.3 \text{ V}$		5.4	
				$V_{CCB} = 5 \text{ V} \pm 0.5 \text{ V}$		6.8	
			Open-drain, Figure 5	$V_{CCB} = 2.5 \text{ V} \pm 0.2 \text{ V}$	2.3	8.8	
				$V_{CCB} = 3.3 \text{ V} \pm 0.3 \text{ V}$	2.4	9.6	
				$V_{CCB} = 5 \text{ V} \pm 0.5 \text{ V}$	2.6	10	
t_{PLH} Figure 8	A	B	Push-pull, Figure 4	$V_{CCB} = 2.5 \text{ V} \pm 0.2 \text{ V}$		6.8	ns
				$V_{CCB} = 3.3 \text{ V} \pm 0.3 \text{ V}$		7.1	
				$V_{CCB} = 5 \text{ V} \pm 0.5 \text{ V}$		7.5	
			Open-drain, Figure 5	$V_{CCB} = 2.5 \text{ V} \pm 0.2 \text{ V}$	45	260	
				$V_{CCB} = 3.3 \text{ V} \pm 0.3 \text{ V}$	36	208	
				$V_{CCB} = 5 \text{ V} \pm 0.5 \text{ V}$	27	198	
t_{PHL} Figure 8	B	A	Push-pull, Figure 4	$V_{CCB} = 2.5 \text{ V} \pm 0.2 \text{ V}$		4.4	ns
				$V_{CCB} = 3.3 \text{ V} \pm 0.3 \text{ V}$		4.5	
				$V_{CCB} = 5 \text{ V} \pm 0.5 \text{ V}$		4.7	
			Open-drain, Figure 5	$V_{CCB} = 2.5 \text{ V} \pm 0.2 \text{ V}$	1.9	5.3	
				$V_{CCB} = 3.3 \text{ V} \pm 0.3 \text{ V}$	1.1	4.4	
				$V_{CCB} = 5 \text{ V} \pm 0.5 \text{ V}$	1.2	4	
t_{PLH} Figure 8	B	A	Push-pull, Figure 4	$V_{CCB} = 2.5 \text{ V} \pm 0.2 \text{ V}$		5.3	ns
				$V_{CCB} = 3.3 \text{ V} \pm 0.3 \text{ V}$		4.5	
				$V_{CCB} = 5 \text{ V} \pm 0.5 \text{ V}$		0.5	
			Open-drain, Figure 5	$V_{CCB} = 2.5 \text{ V} \pm 0.2 \text{ V}$	45	175	
				$V_{CCB} = 3.3 \text{ V} \pm 0.3 \text{ V}$	36	140	
				$V_{CCB} = 5 \text{ V} \pm 0.5 \text{ V}$	27	102	
t_{en} Figure 9	OE	A or B	Push-pull, Figure 6	$V_{CCB} = 2.5 \text{ V} \pm 0.2 \text{ V}$		200	ns
				$V_{CCB} = 3.3 \text{ V} \pm 0.3 \text{ V}$		200	
				$V_{CCB} = 5 \text{ V} \pm 0.5 \text{ V}$		200	
t_{dis} Figure 9	OE	A or B		$V_{CCB} = 2.5 \text{ V} \pm 0.2 \text{ V}$		50	ns
				$V_{CCB} = 3.3 \text{ V} \pm 0.3 \text{ V}$		40	
				$V_{CCB} = 5 \text{ V} \pm 0.5 \text{ V}$		35	
t_{rA}	A-port rise time		Push-pull	$V_{CCB} = 2.5 \text{ V} \pm 0.2 \text{ V}$	3.2	9.5	ns
				$V_{CCB} = 3.3 \text{ V} \pm 0.3 \text{ V}$	2.3	9.3	
				$V_{CCB} = 5 \text{ V} \pm 0.5 \text{ V}$	2	7.6	
			Open-drain	$V_{CCB} = 2.5 \text{ V} \pm 0.2 \text{ V}$	38	165	
				$V_{CCB} = 3.3 \text{ V} \pm 0.3 \text{ V}$	30	132	
				$V_{CCB} = 5 \text{ V} \pm 0.5 \text{ V}$	22	95	
t_{rB}	B-port rise time		Push-pull	$V_{CCB} = 2.5 \text{ V} \pm 0.2 \text{ V}$	1.1	10.8	ns
				$V_{CCB} = 3.3 \text{ V} \pm 0.3 \text{ V}$	1	9.1	
				$V_{CCB} = 5 \text{ V} \pm 0.5 \text{ V}$	1	7.6	
			Open-drain	$V_{CCB} = 2.5 \text{ V} \pm 0.2 \text{ V}$	34	145	
				$V_{CCB} = 3.3 \text{ V} \pm 0.3 \text{ V}$	23	106	
				$V_{CCB} = 5 \text{ V} \pm 0.5 \text{ V}$	10	76	

Switching Characteristics: $V_{CCA} = 1.8\text{ V} \pm 0.15\text{ V}$ (continued)

over recommended operating free-air temperature range, $V_{CCA} = 2.5\text{ V} \pm 0.2\text{ V}$ (unless otherwise noted)

PARAMETER	FROM (INPUT)	TO (OUTPUT)	TEST CONDITIONS (DRIVING)	MIN	MAX	UNIT	
t_{fA}		A-port fall time	Push-pull	$V_{CCB} = 2.5\text{ V} \pm 0.2\text{ V}$	1.9	5.9	ns
				$V_{CCB} = 3.3\text{ V} \pm 0.3\text{ V}$	1.9	6	
				$V_{CCB} = 5\text{ V} \pm 0.5\text{ V}$	1.4	13.3	
			Open-drain	$V_{CCB} = 2.5\text{ V} \pm 0.2\text{ V}$	4.4	6.9	
				$V_{CCB} = 3.3\text{ V} \pm 0.3\text{ V}$	4.3	6.4	
				$V_{CCB} = 5\text{ V} \pm 0.5\text{ V}$	4.2	6.1	
t_{fB}		B-port fall time	Push-pull	$V_{CCB} = 2.5\text{ V} \pm 0.2\text{ V}$	2.2	13.8	
				$V_{CCB} = 3.3\text{ V} \pm 0.3\text{ V}$	2.2	16.2	
				$V_{CCB} = 5\text{ V} \pm 0.5\text{ V}$	2.6	16.2	
			Open-drain	$V_{CCB} = 2.5\text{ V} \pm 0.2\text{ V}$	6.9	13.8	
				$V_{CCB} = 3.3\text{ V} \pm 0.3\text{ V}$	7.5	16.2	
				$V_{CCB} = 5\text{ V} \pm 0.5\text{ V}$	7	16.2	
Max data rate		A or B	Push-pull	$V_{CCB} = 2.5\text{ V} \pm 0.2\text{ V}$	21	Mbps	
				$V_{CCB} = 3.3\text{ V} \pm 0.3\text{ V}$	22		
				$V_{CCB} = 5\text{ V} \pm 0.5\text{ V}$	24		
			Open-drain	$V_{CCB} = 2.5\text{ V} \pm 0.2\text{ V}$	2		
				$V_{CCB} = 3.3\text{ V} \pm 0.3\text{ V}$	2		
				$V_{CCB} = 5\text{ V} \pm 0.5\text{ V}$	2		

6.10 Switching Characteristics: $V_{CCA} = 2.5\text{ V} \pm 0.2\text{ V}$

over recommended operating free-air temperature range, $V_{CCA} = 2.5\text{ V} \pm 0.2\text{ V}$ (unless otherwise noted)

PARAMETER	FROM (INPUT)	TO (OUTPUT)	TEST CONDITIONS (DRIVING)	MIN	MAX	UNIT	
t_{PHL} Figure 8	A	B	Push-pull, Figure 4	$V_{CCB} = 2.5\text{ V} \pm 0.2\text{ V}$	3.2	ns	
				$V_{CCB} = 3.3\text{ V} \pm 0.3\text{ V}$	3.7		
				$V_{CCB} = 5\text{ V} \pm 0.5\text{ V}$	3.8		
			Open-drain, Figure 5	$V_{CCB} = 2.5\text{ V} \pm 0.2\text{ V}$	1.7		6.3
				$V_{CCB} = 3.3\text{ V} \pm 0.3\text{ V}$	2		6
				$V_{CCB} = 5\text{ V} \pm 0.5\text{ V}$	2.1		5.8
t_{PLH} Figure 8			Push-pull, Figure 4	$V_{CCB} = 2.5\text{ V} \pm 0.2\text{ V}$	3.5		
				$V_{CCB} = 3.3\text{ V} \pm 0.3\text{ V}$	4.1		
				$V_{CCB} = 5\text{ V} \pm 0.5\text{ V}$	4.4		
			Open-drain, Figure 5	$V_{CCB} = 2.5\text{ V} \pm 0.2\text{ V}$	43		250
				$V_{CCB} = 3.3\text{ V} \pm 0.3\text{ V}$	36		206
				$V_{CCB} = 5\text{ V} \pm 0.5\text{ V}$	27		190

Switching Characteristics: $V_{CCA} = 2.5\text{ V} \pm 0.2\text{ V}$ (continued)

 over recommended operating free-air temperature range, $V_{CCA} = 2.5\text{ V} \pm 0.2\text{ V}$ (unless otherwise noted)

PARAMETER	FROM (INPUT)	TO (OUTPUT)	TEST CONDITIONS (DRIVING)	MIN	MAX	UNIT	
t_{PHL} Figure 8	B	A	Push-pull, Figure 4	$V_{CCB} = 2.5\text{ V} \pm 0.2\text{ V}$	3	ns	
				$V_{CCB} = 3.3\text{ V} \pm 0.3\text{ V}$	3.6		
				$V_{CCB} = 5\text{ V} \pm 0.5\text{ V}$	4.3		
			Open-drain, Figure 5	$V_{CCB} = 2.5\text{ V} \pm 0.2\text{ V}$	1.8		4.7
				$V_{CCB} = 3.3\text{ V} \pm 0.3\text{ V}$	1.6		4.2
				$V_{CCB} = 5\text{ V} \pm 0.5\text{ V}$	1.2		4
t_{PLH} Figure 8	B	A	Push-pull, Figure 4	$V_{CCB} = 2.5\text{ V} \pm 0.2\text{ V}$	2.5	ns	
				$V_{CCB} = 3.3\text{ V} \pm 0.3\text{ V}$	1.6		
				$V_{CCB} = 5\text{ V} \pm 0.5\text{ V}$	1		
			Open-drain, Figure 5	$V_{CCB} = 2.5\text{ V} \pm 0.2\text{ V}$	44		170
				$V_{CCB} = 3.3\text{ V} \pm 0.3\text{ V}$	37		140
				$V_{CCB} = 5\text{ V} \pm 0.5\text{ V}$	27		103
t_{en} Figure 9	OE	A or B	Push-pull, Figure 6	$V_{CCB} = 2.5\text{ V} \pm 0.2\text{ V}$	200	ns	
				$V_{CCB} = 3.3\text{ V} \pm 0.3\text{ V}$	200		
				$V_{CCB} = 5\text{ V} \pm 0.5\text{ V}$	200		
t_{dis} Figure 9	OE	A or B	Push-pull, Figure 6	$V_{CCB} = 2.5\text{ V} \pm 0.2\text{ V}$	50	ns	
				$V_{CCB} = 3.3\text{ V} \pm 0.3\text{ V}$	40		
				$V_{CCB} = 5\text{ V} \pm 0.5\text{ V}$	35		
t_{rA}	A-port rise time	Push-pull	$V_{CCB} = 2.5\text{ V} \pm 0.2\text{ V}$	2.8	7.4	ns	
			$V_{CCB} = 3.3\text{ V} \pm 0.3\text{ V}$	2.1	6.6		
			$V_{CCB} = 5\text{ V} \pm 0.5\text{ V}$	0.9	5.6		
		Open-drain	$V_{CCB} = 2.5\text{ V} \pm 0.2\text{ V}$	34	149		
			$V_{CCB} = 3.3\text{ V} \pm 0.3\text{ V}$	28	121		
			$V_{CCB} = 5\text{ V} \pm 0.5\text{ V}$	24	89		
t_{rB}	B-port rise time	Push-pull	$V_{CCB} = 2.5\text{ V} \pm 0.2\text{ V}$	1.3	8.3	ns	
			$V_{CCB} = 3.3\text{ V} \pm 0.3\text{ V}$	0.9	7.2		
			$V_{CCB} = 5\text{ V} \pm 0.5\text{ V}$	0.4	6.1		
		Open-drain	$V_{CCB} = 2.5\text{ V} \pm 0.2\text{ V}$	35	151		
			$V_{CCB} = 3.3\text{ V} \pm 0.3\text{ V}$	24	112		
			$V_{CCB} = 5\text{ V} \pm 0.5\text{ V}$	12	81		
t_{fA}	A-port fall time	Push-pull	$V_{CCB} = 2.5\text{ V} \pm 0.2\text{ V}$	1.9	5.7	ns	
			$V_{CCB} = 3.3\text{ V} \pm 0.3\text{ V}$	1.4	5.5		
			$V_{CCB} = 5\text{ V} \pm 0.5\text{ V}$	0.8	5.3		
		Open-drain	$V_{CCB} = 2.5\text{ V} \pm 0.2\text{ V}$	4.4	6.9		
			$V_{CCB} = 3.3\text{ V} \pm 0.3\text{ V}$	4.3	6.2		
			$V_{CCB} = 5\text{ V} \pm 0.5\text{ V}$	4.2	5.8		
t_{fB}	B-port fall time	Push-pull	$V_{CCB} = 2.5\text{ V} \pm 0.2\text{ V}$	2.2	7.8	ns	
			$V_{CCB} = 3.3\text{ V} \pm 0.3\text{ V}$	2.4	6.7		
			$V_{CCB} = 5\text{ V} \pm 0.5\text{ V}$	2.6	6.6		
		Open-drain	$V_{CCB} = 2.5\text{ V} \pm 0.2\text{ V}$	5.1	8.8		
			$V_{CCB} = 3.3\text{ V} \pm 0.3\text{ V}$	5.4	9.4		
			$V_{CCB} = 5\text{ V} \pm 0.5\text{ V}$	5.4	10.4		

Switching Characteristics: $V_{CCA} = 2.5\text{ V} \pm 0.2\text{ V}$ (continued)

 over recommended operating free-air temperature range, $V_{CCA} = 2.5\text{ V} \pm 0.2\text{ V}$ (unless otherwise noted)

PARAMETER	FROM (INPUT)	TO (OUTPUT)	TEST CONDITIONS (DRIVING)	MIN	MAX	UNIT
Max data rate	A or B	Push-pull	$V_{CCB} = 2.5\text{ V} \pm 0.2\text{ V}$	20		Mbps
			$V_{CCB} = 3.3\text{ V} \pm 0.3\text{ V}$	22		
			$V_{CCB} = 5\text{ V} \pm 0.5\text{ V}$	24		
		Open-drain	$V_{CCB} = 2.5\text{ V} \pm 0.2\text{ V}$	2		
			$V_{CCB} = 3.3\text{ V} \pm 0.3\text{ V}$	2		
			$V_{CCB} = 5\text{ V} \pm 0.5\text{ V}$	2		

6.11 Switching Characteristics: $V_{CCA} = 3.3\text{ V} \pm 0.3\text{ V}$

 over recommended operating free-air temperature range, $V_{CCA} = 3.3\text{ V} \pm 0.3\text{ V}$ (unless otherwise noted)

PARAMETER	FROM (INPUT)	TO (OUTPUT)	TEST CONDITIONS (DRIVING)		MIN	MAX	UNIT
t_{PHL} Figure 8	A	B	Push-pull, Figure 4	$V_{CCB} = 3.3\text{ V} \pm 0.3\text{ V}$		2.4	ns
				$V_{CCB} = 5\text{ V} \pm 0.5\text{ V}$		3.1	
			Open-drain, Figure 5	$V_{CCB} = 3.3\text{ V} \pm 0.3\text{ V}$	1.3	4.2	
				$V_{CCB} = 5\text{ V} \pm 0.5\text{ V}$	1.4	4.6	
t_{PLH} Figure 8			Push-pull, Figure 4	$V_{CCB} = 3.3\text{ V} \pm 0.3\text{ V}$		4.2	
				$V_{CCB} = 5\text{ V} \pm 0.5\text{ V}$		4.4	
			Open-drain, Figure 5	$V_{CCB} = 3.3\text{ V} \pm 0.3\text{ V}$	36	204	
				$V_{CCB} = 5\text{ V} \pm 0.5\text{ V}$	28	165	
t_{PHL} Figure 8	B	A	Push-pull, Figure 4	$V_{CCB} = 3.3\text{ V} \pm 0.3\text{ V}$		2.5	ns
				$V_{CCB} = 5\text{ V} \pm 0.5\text{ V}$		3.3	
			Open-drain, Figure 5	$V_{CCB} = 3.3\text{ V} \pm 0.3\text{ V}$	1	124	
				$V_{CCB} = 5\text{ V} \pm 0.5\text{ V}$	1	97	
t_{PLH} Figure 8			Push-pull, Figure 4	$V_{CCB} = 3.3\text{ V} \pm 0.3\text{ V}$		2.5	
				$V_{CCB} = 5\text{ V} \pm 0.5\text{ V}$		2.6	
			Open-drain, Figure 5	$V_{CCB} = 3.3\text{ V} \pm 0.3\text{ V}$	3	139	
				$V_{CCB} = 5\text{ V} \pm 0.5\text{ V}$	3	105	
t_{en} Figure 9	OE	A or B	Push-pull, Figure 6	$V_{CCB} = 3.3\text{ V} \pm 0.3\text{ V}$		200	ns
				$V_{CCB} = 5\text{ V} \pm 0.5\text{ V}$		200	
t_{dis} Figure 9	OE	A or B		$V_{CCB} = 3.3\text{ V} \pm 0.3\text{ V}$		40	ns
				$V_{CCB} = 5\text{ V} \pm 0.5\text{ V}$		9.8	
t_{rA}	A-port rise time		Push-pull	$V_{CCB} = 3.3\text{ V} \pm 0.3\text{ V}$	2.3	5.6	ns
				$V_{CCB} = 5\text{ V} \pm 0.5\text{ V}$	1.9	4.8	
			Open-drain	$V_{CCB} = 3.3\text{ V} \pm 0.3\text{ V}$	25	116	
				$V_{CCB} = 5\text{ V} \pm 0.5\text{ V}$	19	85	
t_{rB}	B-port rise time		Push-pull	$V_{CCB} = 3.3\text{ V} \pm 0.3\text{ V}$	1.6	6.4	ns
				$V_{CCB} = 5\text{ V} \pm 0.5\text{ V}$	0.6	7.4	
			Open-drain	$V_{CCB} = 3.3\text{ V} \pm 0.3\text{ V}$	26	116	
				$V_{CCB} = 5\text{ V} \pm 0.5\text{ V}$	14	72	
t_{fA}	A-port fall time		Push-pull	$V_{CCB} = 3.3\text{ V} \pm 0.3\text{ V}$	1.4	5.4	ns
				$V_{CCB} = 5\text{ V} \pm 0.5\text{ V}$	1	5	
			Open-drain	$V_{CCB} = 3.3\text{ V} \pm 0.3\text{ V}$	4.3	6.1	
				$V_{CCB} = 5\text{ V} \pm 0.5\text{ V}$	4.2	5.7	
t_{fB}	B-port fall time		Push-pull	$V_{CCB} = 3.3\text{ V} \pm 0.3\text{ V}$	2.3	7.4	ns
				$V_{CCB} = 5\text{ V} \pm 0.5\text{ V}$	2.4	7.6	
			Open-drain	$V_{CCB} = 3.3\text{ V} \pm 0.3\text{ V}$	5	7.6	
				$V_{CCB} = 5\text{ V} \pm 0.5\text{ V}$	4.8	8.3	
Max data rate	A or B		Push-pull	$V_{CCB} = 3.3\text{ V} \pm 0.3\text{ V}$	23		Mbps
				$V_{CCB} = 5\text{ V} \pm 0.5\text{ V}$	24		
			Open-drain	$V_{CCB} = 3.3\text{ V} \pm 0.3\text{ V}$	2		
				$V_{CCB} = 5\text{ V} \pm 0.5\text{ V}$	2		

6.12 Typical Characteristics

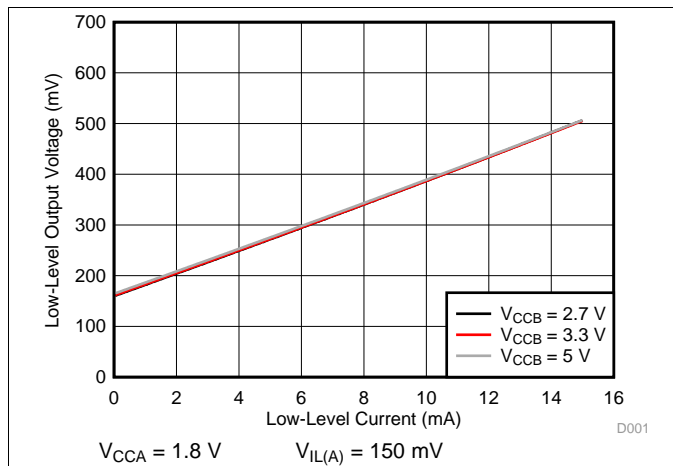

Figure 1. Low-Level Output Voltage ($V_{OL(Bx)}$) vs Low-Level Current ($I_{OL(Bx)}$)

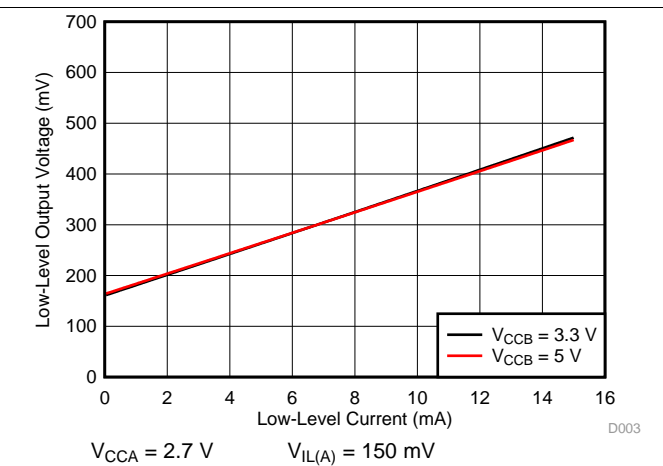

Figure 2. Low-Level Output Voltage ($V_{OL(Bx)}$) vs Low-Level Current ($I_{OL(Bx)}$)

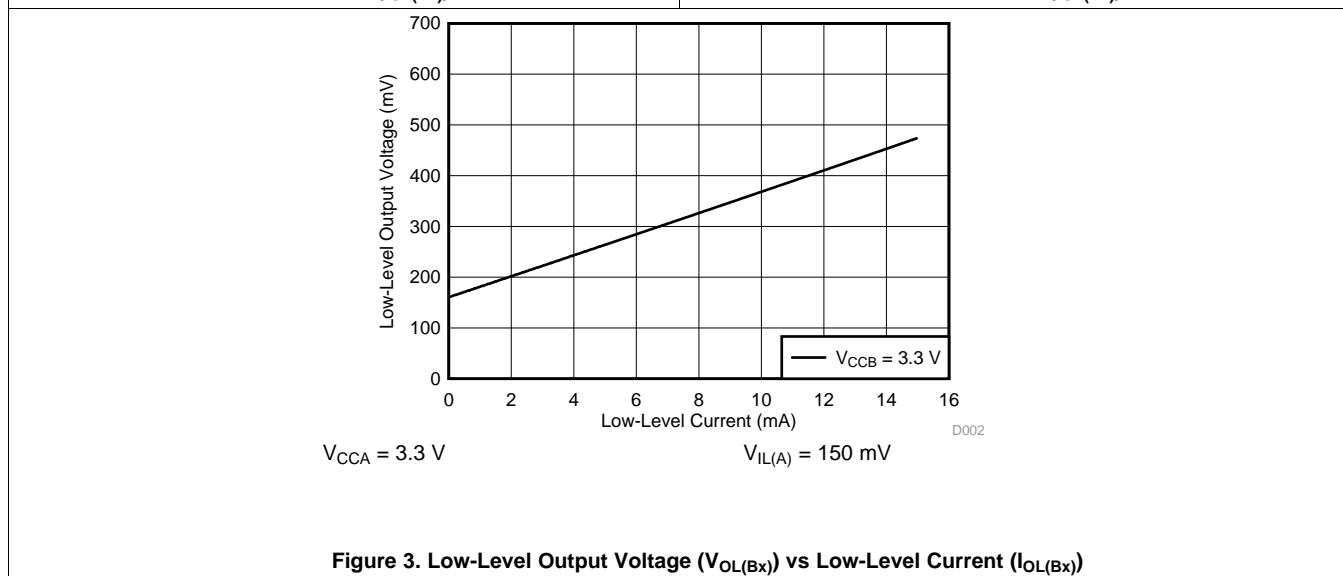

Figure 3. Low-Level Output Voltage ($V_{OL(Bx)}$) vs Low-Level Current ($I_{OL(Bx)}$)

7 Parameter Measurement Information

7.1 Load Circuits

Figure 4 shows the push-pull driver circuit used for measuring data rate, pulse duration, propagation delay, output rise-time and fall-time. Figure 5 shows the open-drain driver circuit used for measuring data rate, pulse duration, propagation delay, output rise-time and fall-time.

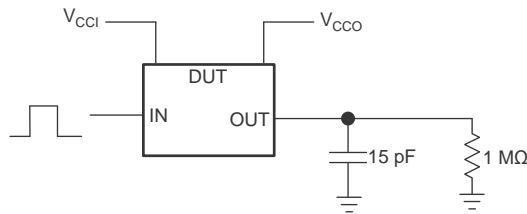

Figure 4. Data Rate, Pulse Duration, Propagation Delay, Output Rise-Time and Fall-Time Measurement Using a Push-Pull Driver

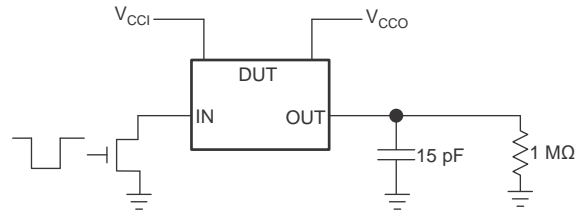

Figure 5. Data Rate, Pulse Duration, Propagation Delay, Output Rise-Time and Fall-Time Measurement Using an Open-Drain Driver

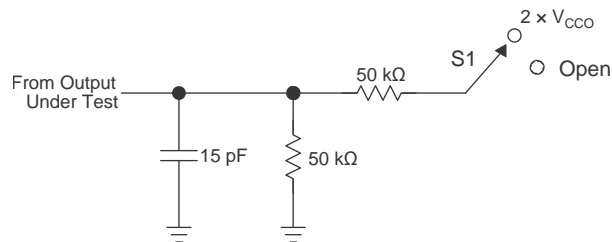

Figure 6. Load Circuit for Enable-Time and Disable-Time Measurement

TEST	S1
t_{PZL} / t_{PLZ} (t_{dis})	$2 \times V_{CCO}$
t_{PHZ} / t_{PZH} (t_{en})	Open

1. t_{PZL} and t_{PHZ} are the same as t_{dis} .
2. t_{PZL} and t_{PZH} are the same as t_{en} .
3. V_{CCI} is the V_{CC} associated with the input port.
4. V_{CCO} is the V_{CC} associated with the output port.

7.2 Voltage Waveforms

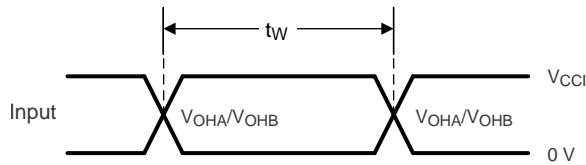

Figure 7. Pulse Duration (Push-Pull)

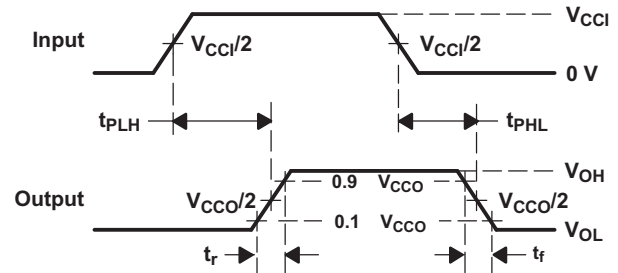
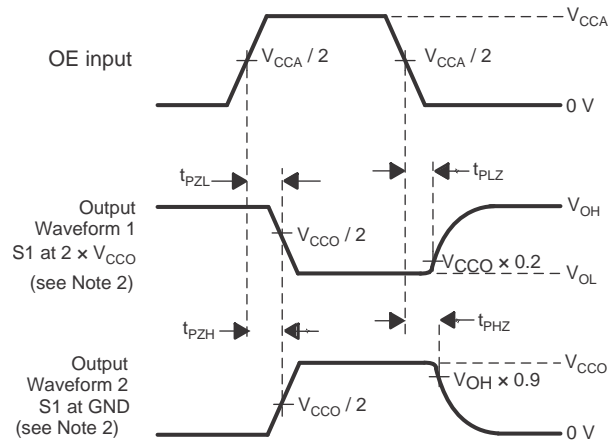

Figure 8. Propagation Delay Times



- C_L includes probe and jig capacitance.
- Waveform 1 in Figure 9 is for an output with internal such that the output is high, except when OE is high (see Figure 6). Waveform 2 in Figure 9 is for an output with conditions such that the output is low, except when OE is high.
- All input pulses are supplied by generators having the following characteristics: $PRR \leq 10$ MHz, $Z_O = 50 \Omega$, $dv/dt \geq 1$ V/ns.
- The outputs are measured one at a time, with one transition per measurement.
- t_{PLZ} and t_{PHZ} are the same as t_{dis} .
- t_{PZL} and t_{PZH} are the same as t_{en} .
- t_{PLH} and t_{PHL} are the same as t_{pd} .
- V_{CCI} is the V_{CC} associated with the input port.
- V_{CCO} is the V_{CC} associated with the output port.

Figure 9. Enable and Disable Times

8 Detailed Description

8.1 Overview

The TXS0101 device is a directionless voltage-level translator specifically designed for translating logic voltage levels. The A port is able to accept I/O voltages ranging from 1.65 V to 3.6 V, while the B port can accept I/O voltages from 2.3 V to 5.5 V. The device is a pass gate architecture with edge rate accelerators (one shots) to improve the overall data rate. 10 k Ω pullup resistors, commonly used in open drain applications, have been conveniently integrated so that an external resistor is not needed. While this device is designed for open drain applications, the device can also translate push-pull CMOS logic outputs.

8.2 Functional Block Diagram

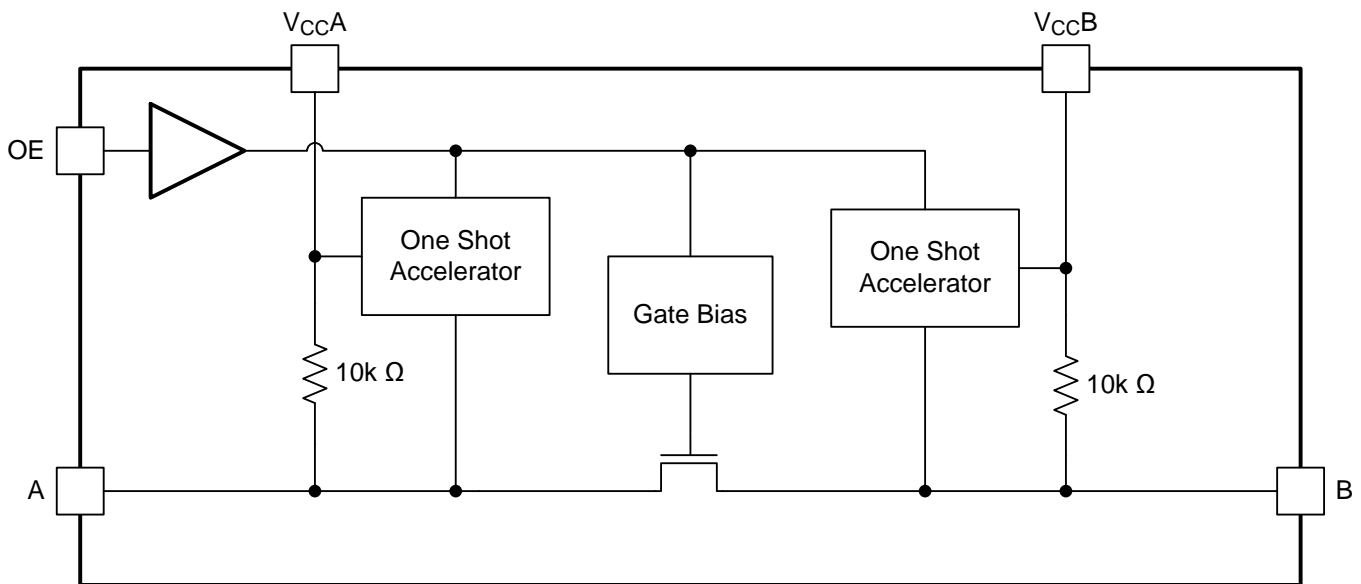

8.3 Feature Description

8.3.1 Architecture

The TXS0101 architecture (see Figure 10) does not require a direction-control signal to control the direction of data flow from A to B or from B to A.

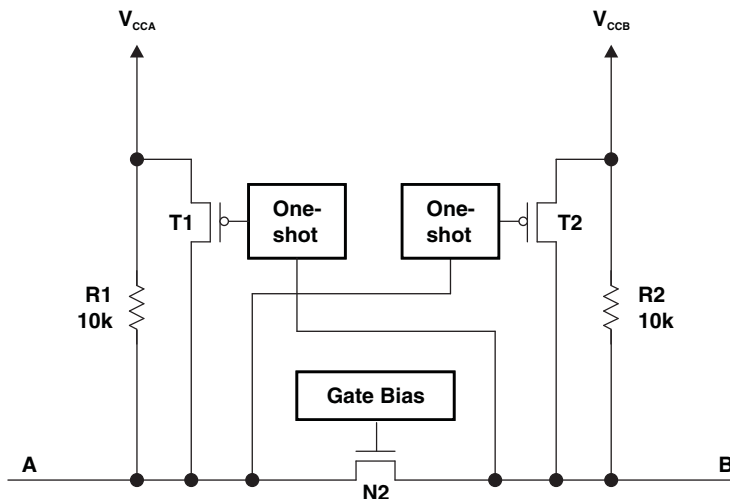

Figure 10. Architecture of a TXS01xx Cell

Each A-port I/O has an internal 10 k Ω pullup resistor to V_{CCA} , and each B-port I/O has an internal 10 k Ω pullup resistor to V_{CCB} . The output one-shots detect rising edges on the A or B ports. During a rising edge, the one-shot turns on the PMOS transistors (T1,T2) for a short duration, which speeds up the low-to-high transition.

8.3.2 Input Driver Requirements

The fall time (t_{fA} , t_{fB}) of a signal depends on the output impedance of the external device driving the data I/Os of the TXS0101. Similarly, the t_{PHL} and max data rates also depend on the output impedance of the external driver. The values for t_{fA} , t_{fB} , t_{PHL} , and maximum data rates in the data sheet assume that the output impedance of the external driver is less than 50 Ω .

8.3.3 Power Up

During operation, ensure that $V_{CCA} \leq V_{CCB}$ at all times. During power-up sequencing, $V_{CCA} \geq V_{CCB}$ does not damage the device, so any power supply can be ramped up first.

8.3.4 Enable and Disable

The TXS0101 has an OE input that is used to disable the device by setting OE low, which places all I/Os in the Hi-Z state. The disable time (t_{dis}) indicates the delay between the time when OE goes low and when the outputs actually get disabled (Hi-Z). The enable time (t_{en}) indicates the amount of time the user must allow for the one-shot circuitry to become operational after OE is taken high.

8.3.5 Pullup or Pulldown Resistors on I/O Lines

Each A-port I/O has an internal 10 k Ω pullup resistor to V_{CCA} , and each B-port I/O has an internal 10 k Ω pullup resistor to V_{CCB} . If a smaller value of pullup resistor is required, an external resistor must be added from the I/O to V_{CCA} or V_{CCB} (in parallel with the internal 10 k Ω resistors).

8.4 Device Functional Modes

The TXS0101 device has two functional modes, enabled and disabled. To disable the device set the OE input low, which places all I/Os in a high impedance state. Setting the OE input high will enable the device.

9 Application and Implementation

NOTE

Information in the following applications sections is not part of the TI component specification, and TI does not warrant its accuracy or completeness. TI's customers are responsible for determining suitability of components for their purposes. Customers should validate and test their design implementation to confirm system functionality.

9.1 Application Information

The TXS0101 can be used in level-translation applications for interfacing devices or systems operating at different interface voltages with one another. The TXS0101 is ideal for use in applications where an open-drain driver is connected to the data I/Os. The TXB0101 can also be used in applications where a push-pull driver is connected to the data I/Os, but the TXB0102 might be a better option for such push-pull applications.

9.2 Typical Application

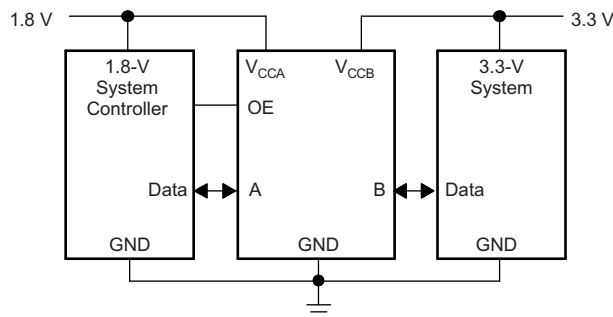

Figure 11. Typical Application Schematic

9.2.1 Design Requirements

For this design example, use the parameters listed in [Table 1](#).

Table 1. Design Parameters

DESIGN PARAMETER	EXAMPLE VALUE
Input voltage range	1.65 to 3.6 V
Output voltage range	2.3 to 5.5 V

9.2.2 Detailed Design Procedure

To begin the design process, determine the following:

- Input voltage range
 - Use the supply voltage of the device that is driving the TXS0101 device to determine the input voltage range. For a valid logic high the value must exceed the V_{IH} of the input port. For a valid logic low the value must be less than the V_{IL} of the input port.
- Output voltage range
 - Use the supply voltage of the device that the TXS0101 device is driving to determine the output voltage range.
 - The TXS0101 device has 10 k Ω internal pullup resistors. External pullup resistors can be added to reduce the total RC of a signal trace if necessary.

- An external pull down resistor decreases the output V_{OH} and V_{OL} . Use Equation 1 to calculate the V_{OH} as a result of an external pull down resistor.

$$V_{OH} = V_{CCx} \times R_{PD} / (R_{PD} + 10 \text{ k}\Omega)$$

where

- V_{CCx} is the supply voltage on either V_{CCA} or V_{CCB}
- R_{PD} is the value of the external pull down resistor

(1)

9.2.3 Application Curve

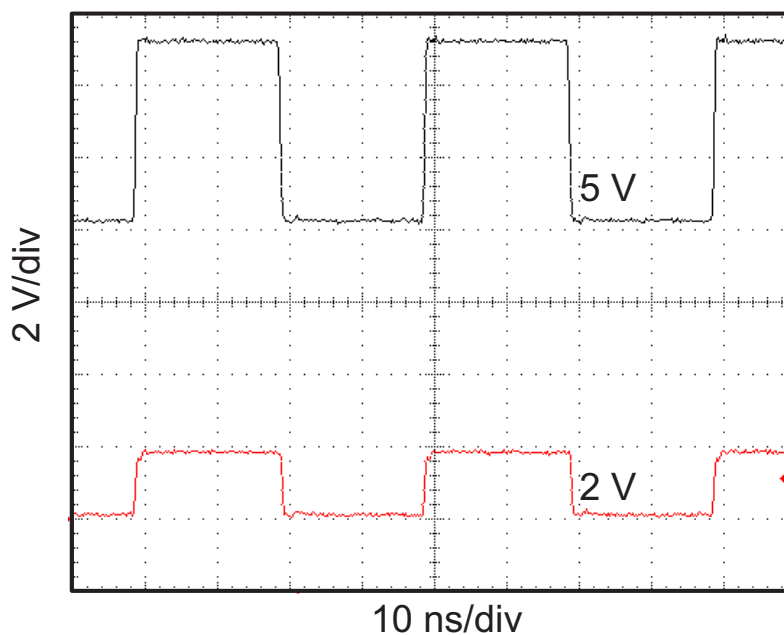

$V_{CCA} = 1.8 \text{ V}$

$V_{CCB} = 5 \text{ V}$

Figure 12. Level-Translation of a 2.5-MHz Signal

10 Power Supply Recommendations

The TXS0101 device uses two separate configurable power-supply rails, V_{CCA} and V_{CCB} . V_{CCB} accepts any supply voltage from 2.3 V to 5.5 V and V_{CCA} accepts any supply voltage from 1.65 V to 3.6 V as long as V_S is less than or equal to V_{CCB} . The A port and B port are designed to track V_{CCA} and V_{CCB} respectively allowing for low voltage bidirectional translation between any of the 1.8 V, 2.5 V, 3.3 V, and 5 V voltage nodes.

The TXS0101 device does not require power sequencing between V_{CCA} and V_{CCB} during power-up so the power-supply rails can be ramped in any order. A V_{CCA} value greater than or equal to V_{CCB} ($V_{CCA} \geq V_{CCB}$) does not damage the device, but during operation, V_{CCA} must be less than or equal to V_{CCB} ($V_{CCA} \leq V_{CCB}$) at all times.

The output-enable (OE) input circuit is designed so that it is supplied by V_{CCA} and when the (OE) input is low, all outputs are placed in the high-impedance state. To ensure the high-impedance state of the outputs during power up or power down, the OE input pin must be tied to GND through a pull-down resistor and must not be enabled until V_{CCA} and V_{CCB} are fully ramped and stable. The minimum value of the pull-down resistor to ground is determined by the current-sourcing capability of the driver.

11 Layout

11.1 Layout Guidelines

To ensure reliability of the device, following common printed-circuit board layout guidelines is recommended.

- Bypass capacitors should be used on power supplies.
- Short trace lengths should be used to avoid excessive loading.
- PCB signal trace-lengths must be kept short enough so that the round-trip delay of any reflection is less than the one shot duration, approximately 30 ns, ensuring that any reflection encounters low impedance at the source driver.
- Placing pads on the signal paths for loading capacitors or pullup resistors to help adjust rise and fall times of signals depending on the system requirements

11.2 Layout Example

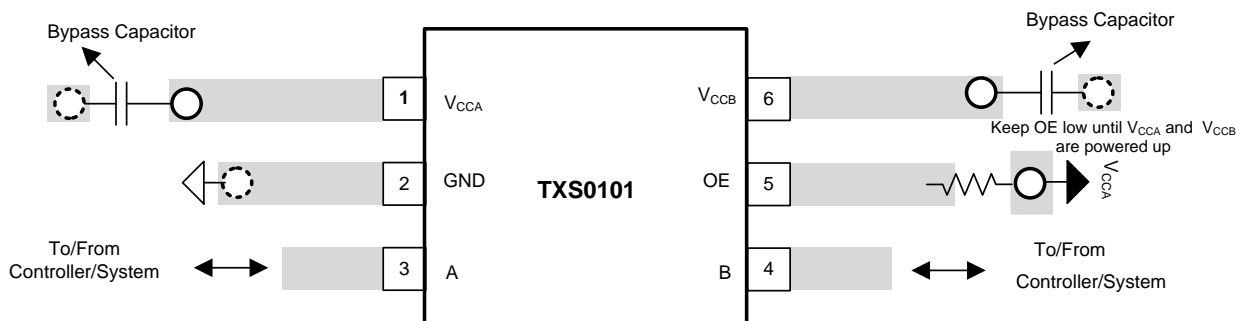
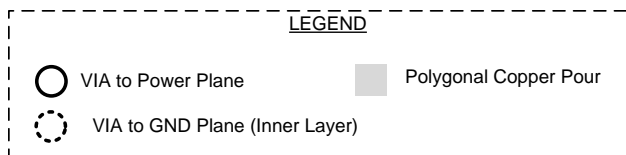

Figure 13. Typical Layout of TXS0101

12 Device and Documentation Support

12.1 Device Support

12.1.1 Related Documentation

For related documentation, see the following:

- [A Guide to Voltage Translation With TXS-Type Translators](#), SCEA044
- [Introduction to Logic](#), SLVA700

12.2 Receiving Notification of Documentation Updates

To receive notification of documentation updates, navigate to the device product folder on ti.com. In the upper right corner, click on *Alert me* to register and receive a weekly digest of any product information that has changed. For change details, review the revision history included in any revised document.

12.3 Community Resources

The following links connect to TI community resources. Linked contents are provided "AS IS" by the respective contributors. They do not constitute TI specifications and do not necessarily reflect TI's views; see TI's [Terms of Use](#).

TI E2E™ Online Community *TI's Engineer-to-Engineer (E2E) Community*. Created to foster collaboration among engineers. At e2e.ti.com, you can ask questions, share knowledge, explore ideas and help solve problems with fellow engineers.

Design Support *TI's Design Support* Quickly find helpful E2E forums along with design support tools and contact information for technical support.

12.4 Trademarks

NanoFree, E2E are trademarks of Texas Instruments.
All other trademarks are the property of their respective owners.

12.5 Electrostatic Discharge Caution



These devices have limited built-in ESD protection. The leads should be shorted together or the device placed in conductive foam during storage or handling to prevent electrostatic damage to the MOS gates.

12.6 Glossary

[SLYZ022](#) — *TI Glossary*.

This glossary lists and explains terms, acronyms, and definitions.

13 Mechanical, Packaging, and Orderable Information

The following pages include mechanical, packaging, and orderable information. This information is the most current data available for the designated devices. This data is subject to change without notice and revision of this document. For browser-based versions of this data sheet, refer to the left-hand navigation.

PACKAGING INFORMATION

Orderable Device	Status (1)	Package Type	Package Drawing	Pins	Package Qty	Eco Plan (2)	Lead/Ball Finish (6)	MSL Peak Temp (3)	Op Temp (°C)	Device Marking (4/5)	Samples
TXS0101DBVR	ACTIVE	SOT-23	DBV	6	3000	Green (RoHS & no Sb/Br)	CU NIPDAU	Level-1-260C-UNLIM	-40 to 85	(NFFF, NFFR)	Samples
TXS0101DBVRG4	ACTIVE	SOT-23	DBV	6	3000	Green (RoHS & no Sb/Br)	CU NIPDAU	Level-1-260C-UNLIM	-40 to 85	(NFFF, NFFR)	Samples
TXS0101DBVT	ACTIVE	SOT-23	DBV	6	250	Green (RoHS & no Sb/Br)	CU NIPDAU	Level-1-260C-UNLIM	-40 to 85	NFFR	Samples
TXS0101DCKR	ACTIVE	SC70	DCK	6	3000	Green (RoHS & no Sb/Br)	CU NIPDAU	Level-1-260C-UNLIM	-40 to 85	2GO	Samples
TXS0101DCKT	ACTIVE	SC70	DCK	6	250	Green (RoHS & no Sb/Br)	CU NIPDAU	Level-1-260C-UNLIM	-40 to 85	2GO	Samples
TXS0101DRLR	ACTIVE	SOT-5X3	DRL	6	4000	Green (RoHS & no Sb/Br)	CU NIPDAUAG	Level-1-260C-UNLIM	-40 to 85	2GR	Samples
TXS0101DRLRG4	ACTIVE	SOT-5X3	DRL	6	4000	Green (RoHS & no Sb/Br)	CU NIPDAUAG	Level-1-260C-UNLIM	-40 to 85	2GR	Samples
TXS0101YZPR	ACTIVE	DSBGA	YZP	6	3000	Green (RoHS & no Sb/Br)	SNAGCU	Level-1-260C-UNLIM	-40 to 85	(2G7, 2GN)	Samples

(1) The marketing status values are defined as follows:

ACTIVE: Product device recommended for new designs.

LIFEBUY: TI has announced that the device will be discontinued, and a lifetime-buy period is in effect.

NRND: Not recommended for new designs. Device is in production to support existing customers, but TI does not recommend using this part in a new design.

PREVIEW: Device has been announced but is not in production. Samples may or may not be available.

OBSOLETE: TI has discontinued the production of the device.

(2) **RoHS:** TI defines "RoHS" to mean semiconductor products that are compliant with the current EU RoHS requirements for all 10 RoHS substances, including the requirement that RoHS substance do not exceed 0.1% by weight in homogeneous materials. Where designed to be soldered at high temperatures, "RoHS" products are suitable for use in specified lead-free processes. TI may reference these types of products as "Pb-Free".

RoHS Exempt: TI defines "RoHS Exempt" to mean products that contain lead but are compliant with EU RoHS pursuant to a specific EU RoHS exemption.

Green: TI defines "Green" to mean the content of Chlorine (Cl) and Bromine (Br) based flame retardants meet JS709B low halogen requirements of <=100ppm threshold. Antimony trioxide based flame retardants must also meet the <=1000ppm threshold requirement.

(3) MSL, Peak Temp. - The Moisture Sensitivity Level rating according to the JEDEC industry standard classifications, and peak solder temperature.

(4) There may be additional marking, which relates to the logo, the lot trace code information, or the environmental category on the device.

⁽⁵⁾ Multiple Device Markings will be inside parentheses. Only one Device Marking contained in parentheses and separated by a "-" will appear on a device. If a line is indented then it is a continuation of the previous line and the two combined represent the entire Device Marking for that device.

⁽⁶⁾ Lead/Ball Finish - Orderable Devices may have multiple material finish options. Finish options are separated by a vertical ruled line. Lead/Ball Finish values may wrap to two lines if the finish value exceeds the maximum column width.

Important Information and Disclaimer:The information provided on this page represents TI's knowledge and belief as of the date that it is provided. TI bases its knowledge and belief on information provided by third parties, and makes no representation or warranty as to the accuracy of such information. Efforts are underway to better integrate information from third parties. TI has taken and continues to take reasonable steps to provide representative and accurate information but may not have conducted destructive testing or chemical analysis on incoming materials and chemicals. TI and TI suppliers consider certain information to be proprietary, and thus CAS numbers and other limited information may not be available for release.

In no event shall TI's liability arising out of such information exceed the total purchase price of the TI part(s) at issue in this document sold by TI to Customer on an annual basis.

TAPE AND REEL INFORMATION



QUADRANT ASSIGNMENTS FOR PIN 1 ORIENTATION IN TAPE



*All dimensions are nominal

Device	Package Type	Package Drawing	Pins	SPQ	Reel Diameter (mm)	Reel Width W1 (mm)	A0 (mm)	B0 (mm)	K0 (mm)	P1 (mm)	W (mm)	Pin1 Quadrant
TXS0101DBVR	SOT-23	DBV	6	3000	180.0	8.4	3.23	3.17	1.37	4.0	8.0	Q3
TXS0101DBVT	SOT-23	DBV	6	250	180.0	8.4	3.23	3.17	1.37	4.0	8.0	Q3
TXS0101DCKR	SC70	DCK	6	3000	179.0	8.4	2.2	2.5	1.2	4.0	8.0	Q3
TXS0101DCKT	SC70	DCK	6	250	179.0	8.4	2.2	2.5	1.2	4.0	8.0	Q3
TXS0101DRLR	SOT-5X3	DRL	6	4000	180.0	8.4	1.98	1.78	0.69	4.0	8.0	Q3
TXS0101YZPR	DSBGA	YZP	6	3000	178.0	9.2	1.02	1.52	0.63	4.0	8.0	Q1

TAPE AND REEL BOX DIMENSIONS

*All dimensions are nominal

Device	Package Type	Package Drawing	Pins	SPQ	Length (mm)	Width (mm)	Height (mm)
TXS0101DBVR	SOT-23	DBV	6	3000	202.0	201.0	28.0
TXS0101DBVT	SOT-23	DBV	6	250	202.0	201.0	28.0
TXS0101DCKR	SC70	DCK	6	3000	203.0	203.0	35.0
TXS0101DCKT	SC70	DCK	6	250	203.0	203.0	35.0
TXS0101DRLR	SOT-5X3	DRL	6	4000	202.0	201.0	28.0
TXS0101YZPR	DSBGA	YZP	6	3000	220.0	220.0	35.0

DCK (R-PDSO-G6)

PLASTIC SMALL-OUTLINE PACKAGE



- NOTES:
- All linear dimensions are in millimeters.
 - This drawing is subject to change without notice.
 - Body dimensions do not include mold flash or protrusion. Mold flash and protrusion shall not exceed 0.15 per side.
 - Falls within JEDEC MO-203 variation AB.

DCK (R-PDSO-G6)

PLASTIC SMALL OUTLINE

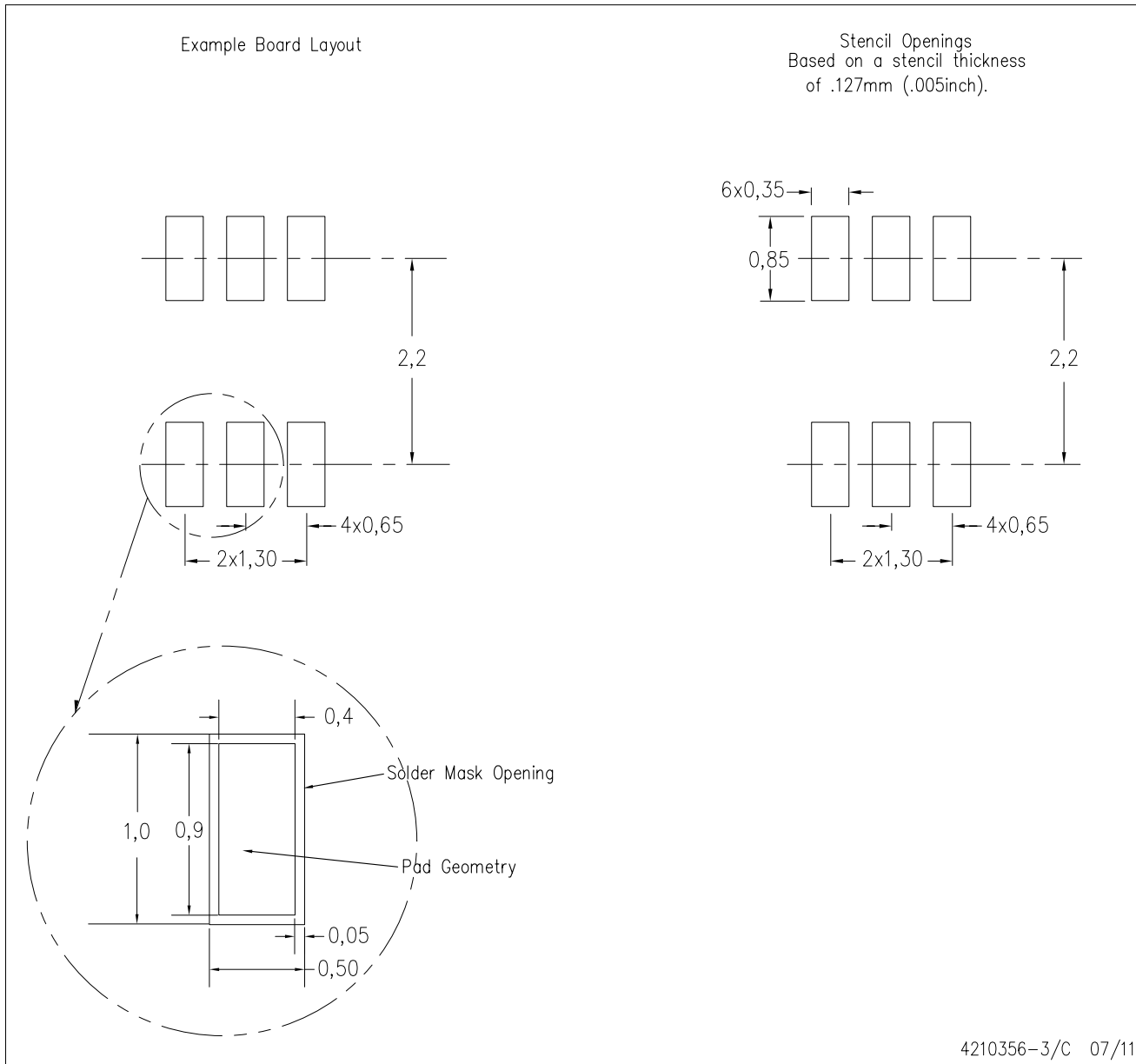

- NOTES:
- All linear dimensions are in millimeters.
 - This drawing is subject to change without notice.
 - Customers should place a note on the circuit board fabrication drawing not to alter the center solder mask defined pad.
 - Publication IPC-7351 is recommended for alternate designs.
 - Laser cutting apertures with trapezoidal walls and also rounding corners will offer better paste release. Customers should contact their board assembly site for stencil design recommendations. Example stencil design based on a 50% volumetric metal load solder paste. Refer to IPC-7525 for other stencil recommendations.

DRL0006A

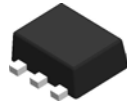

PACKAGE OUTLINE

SOT - 0.6 mm max height

PLASTIC SMALL OUTLINE

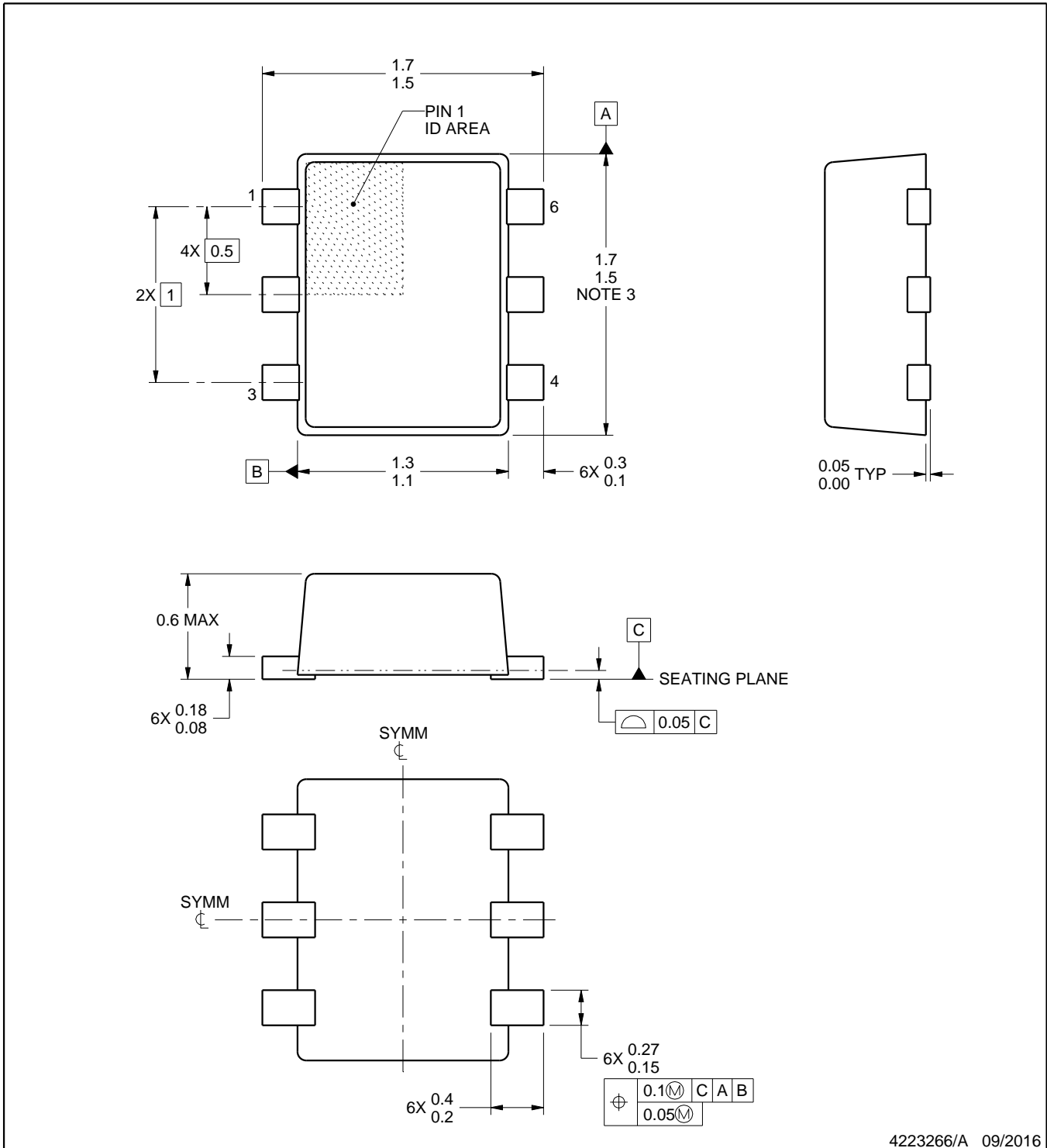

4223266/A 09/2016

NOTES:

1. All linear dimensions are in millimeters. Any dimensions in parenthesis are for reference only. Dimensioning and tolerancing per ASME Y14.5M.
2. This drawing is subject to change without notice.
3. This dimension does not include mold flash, protrusions, or gate burrs. Mold flash, protrusions, or gate burrs shall not exceed 0.15 mm per side.

EXAMPLE BOARD LAYOUT

DRL0006A

SOT - 0.6 mm max height

PLASTIC SMALL OUTLINE

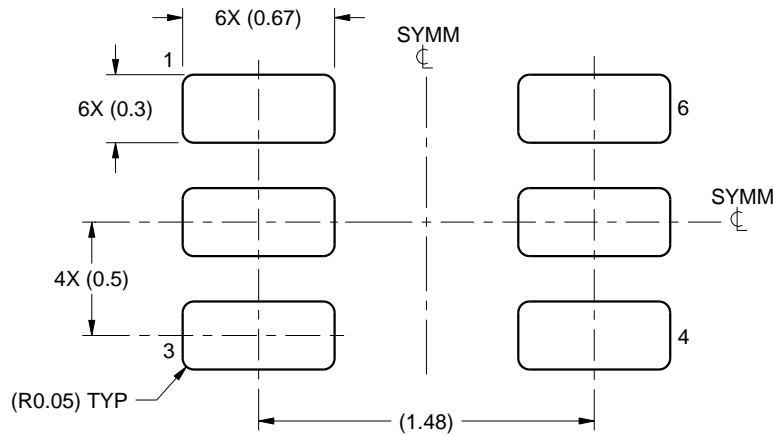

LAND PATTERN EXAMPLE
SCALE:30X



SOLDERMASK DETAILS

4223266/A 09/2016

NOTES: (continued)

- 4. Publication IPC-7351 may have alternate designs.
- 5. Solder mask tolerances between and around signal pads can vary based on board fabrication site.

EXAMPLE STENCIL DESIGN

DRL0006A

SOT - 0.6 mm max height

PLASTIC SMALL OUTLINE



SOLDER PASTE EXAMPLE
BASED ON 0.1 mm THICK STENCIL
SCALE:30X

4223266/A 09/2016

NOTES: (continued)

6. Laser cutting apertures with trapezoidal walls and rounded corners may offer better paste release. IPC-7525 may have alternate design recommendations.
7. Board assembly site may have different recommendations for stencil design.

YZP0006



PACKAGE OUTLINE

DSBGA - 0.5 mm max height

DIE SIZE BALL GRID ARRAY

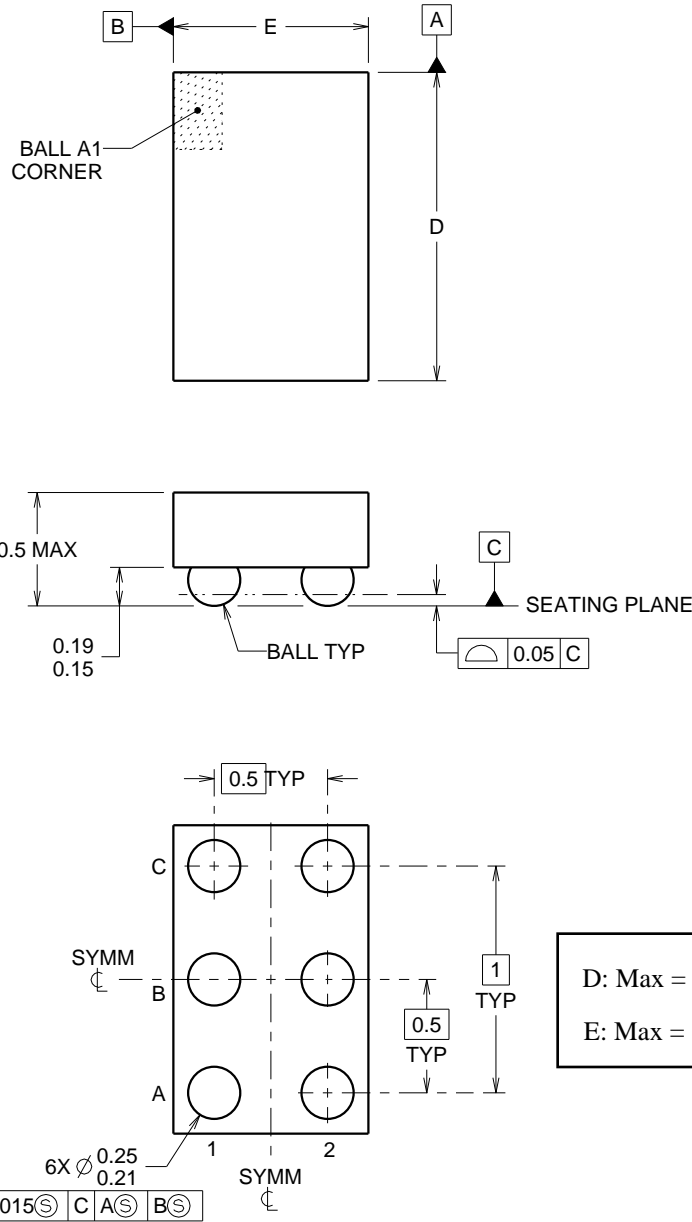

D: Max = 1.418 mm, Min = 1.358 mm
 E: Max = 0.918 mm, Min = 0.858 mm

4219524/A 06/2014

NOTES:

NanoFree Is a trademark of Texas Instruments.

1. All linear dimensions are in millimeters. Any dimensions in parenthesis are for reference only. Dimensioning and tolerancing per ASME Y14.5M.
2. This drawing is subject to change without notice.
3. NanoFree™ package configuration.

EXAMPLE BOARD LAYOUT

YZP0006

DSBGA - 0.5 mm max height

DIE SIZE BALL GRID ARRAY



LAND PATTERN EXAMPLE
SCALE:40X



SOLDER MASK DETAILS
NOT TO SCALE

4219524/A 06/2014

NOTES: (continued)

- Final dimensions may vary due to manufacturing tolerance considerations and also routing constraints. For more information, see Texas Instruments literature number SBVA017 (www.ti.com/lit/sbva017).

EXAMPLE STENCIL DESIGN

YZP0006

DSBGA - 0.5 mm max height

DIE SIZE BALL GRID ARRAY

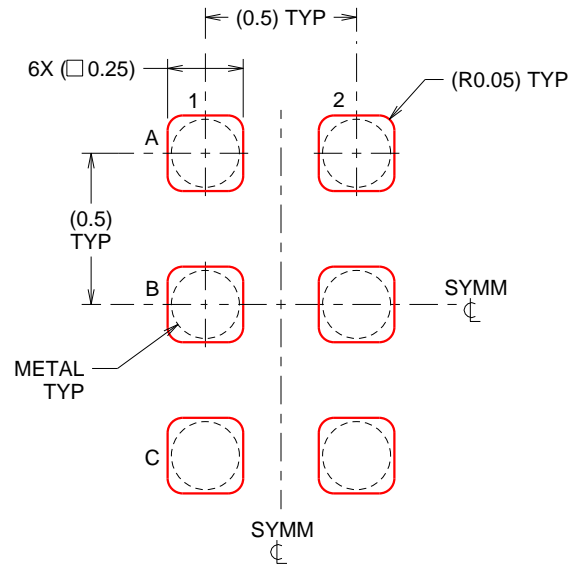

SOLDER PASTE EXAMPLE
BASED ON 0.1 mm THICK STENCIL
SCALE:40X

4219524/A 06/2014

NOTES: (continued)

5. Laser cutting apertures with trapezoidal walls and rounded corners may offer better paste release.

EXAMPLE BOARD LAYOUT

DBV0006A

SOT-23 - 1.45 mm max height

SMALL OUTLINE TRANSISTOR

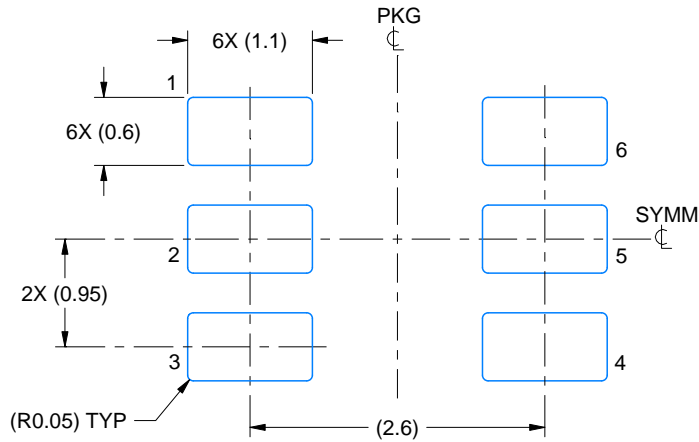

LAND PATTERN EXAMPLE
EXPOSED METAL SHOWN
SCALE:15X

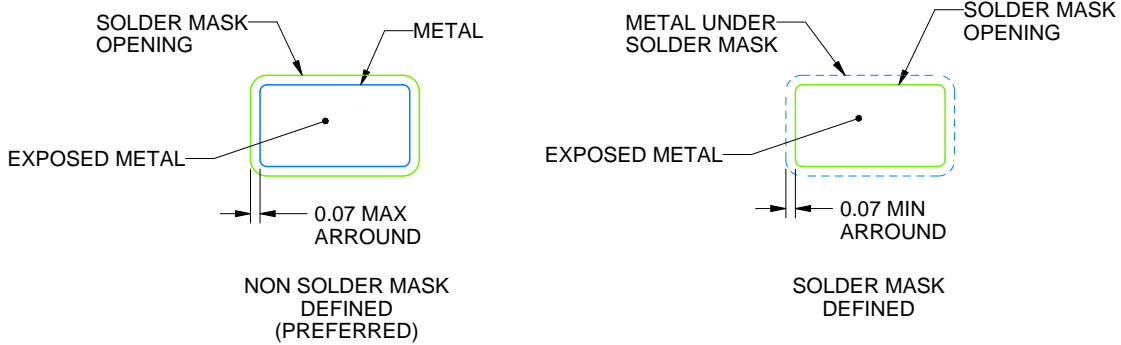

SOLDER MASK DETAILS

4214840/B 03/2018

NOTES: (continued)

- 6. Publication IPC-7351 may have alternate designs.
- 7. Solder mask tolerances between and around signal pads can vary based on board fabrication site.

EXAMPLE STENCIL DESIGN

DBV0006A

SOT-23 - 1.45 mm max height

SMALL OUTLINE TRANSISTOR

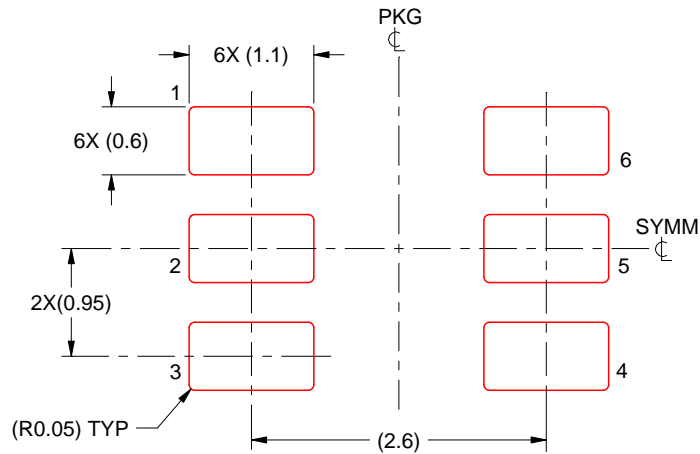

SOLDER PASTE EXAMPLE
BASED ON 0.125 mm THICK STENCIL
SCALE:15X

4214840/B 03/2018

NOTES: (continued)

8. Laser cutting apertures with trapezoidal walls and rounded corners may offer better paste release. IPC-7525 may have alternate design recommendations.
9. Board assembly site may have different recommendations for stencil design.

IMPORTANT NOTICE AND DISCLAIMER

TI PROVIDES TECHNICAL AND RELIABILITY DATA (INCLUDING DATASHEETS), DESIGN RESOURCES (INCLUDING REFERENCE DESIGNS), APPLICATION OR OTHER DESIGN ADVICE, WEB TOOLS, SAFETY INFORMATION, AND OTHER RESOURCES "AS IS" AND WITH ALL FAULTS, AND DISCLAIMS ALL WARRANTIES, EXPRESS AND IMPLIED, INCLUDING WITHOUT LIMITATION ANY IMPLIED WARRANTIES OF MERCHANTABILITY, FITNESS FOR A PARTICULAR PURPOSE OR NON-INFRINGEMENT OF THIRD PARTY INTELLECTUAL PROPERTY RIGHTS.

These resources are intended for skilled developers designing with TI products. You are solely responsible for (1) selecting the appropriate TI products for your application, (2) designing, validating and testing your application, and (3) ensuring your application meets applicable standards, and any other safety, security, or other requirements. These resources are subject to change without notice. TI grants you permission to use these resources only for development of an application that uses the TI products described in the resource. Other reproduction and display of these resources is prohibited. No license is granted to any other TI intellectual property right or to any third party intellectual property right. TI disclaims responsibility for, and you will fully indemnify TI and its representatives against, any claims, damages, costs, losses, and liabilities arising out of your use of these resources.

TI's products are provided subject to TI's Terms of Sale (www.ti.com/legal/termsofsale.html) or other applicable terms available either on ti.com or provided in conjunction with such TI products. TI's provision of these resources does not expand or otherwise alter TI's applicable warranties or warranty disclaimers for TI products.

Mailing Address: Texas Instruments, Post Office Box 655303, Dallas, Texas 75265
Copyright © 2019, Texas Instruments Incorporated

Looking for pricing, stock, or lifecycle information?

Click below to explore more details on WIN SOURCE:

 [View TXS0101DBVTG4 on WIN SOURCE](#)

 [Texas Instruments](#) Information

Optimize Your Supply Chain with WIN SOURCE Solutions

-  Global Sourcing Solution
-  Obsolete Management
-  Cost Control Management
-  Shortage Management
-  Alternative Solution
-  Excess Inventory Management