

8-CHANNEL POWER-SUPPLY SEQUENCER AND MONITOR

FEATURES

- Single Supply Voltage: 3.3 V
- Low Power Consumption
- Sequences and Monitors up to Eight Voltage Rails
- Rail Voltages Sampled Every 50 μ s With 3.2-mV Resolution
- Four Configurable Digital Outputs for Power-On Reset and Other Functions
- Configurable Rail-Enable Output Polarity
- Flexible Rail Sequencing: Timeline (ms), Parent Rail Regulation Window, Parent Rail Achieving Defined Threshold
- Under- and Overvoltage Thresholds: Settable Per-Rail
- Regulation Expiration Time: Settable Per-Rail
- Flexible Rail Shutdown: Parent Rail Shutdown Can Shut Down Child Rails, Independent Rail Configuration
- Per-Rail Alarm Conditions, With Timestamp: Under- and Overvoltage Glitch, Sustained Under- and/or Overvoltage, Rail Did Not Start
- I²C Interface for Configuration and Monitoring
- Microsoft[®] Windows[®] GUI for Configuration and Monitoring

APPLICATIONS

- Telecommunications Switches
- Servers
- Networking Equipment
- Test Equipment
- Any System Requiring Sequencing of Multiple Voltage Rails

DESCRIPTION

The UCD9080 power-supply sequencer controls the enable sequence of up to eight independent voltage rails and provides four general-purpose digital outputs. The device operates from a 3.3-V supply, provides 3.2-mV resolution of voltage rails, and requires no external memory or clock. The UCD9080 monitors the voltage rails independently at more than a 20-kHz rate and has a high degree of rail sequence and rail error-response configurability. The sequencing of rails can be based on time or on time in conjunction with other rails achieving regulation or a voltage threshold. In addition, each rail is monitored for undervoltage and overvoltage glitches and thresholds. Each rail the UCD9080 monitors can be configured to shut down a user-defined set of other rails, and alarm conditions are monitored on a per-rail basis.

Figure 1 shows the UCD9080 power-supply sequencer in a typical application.

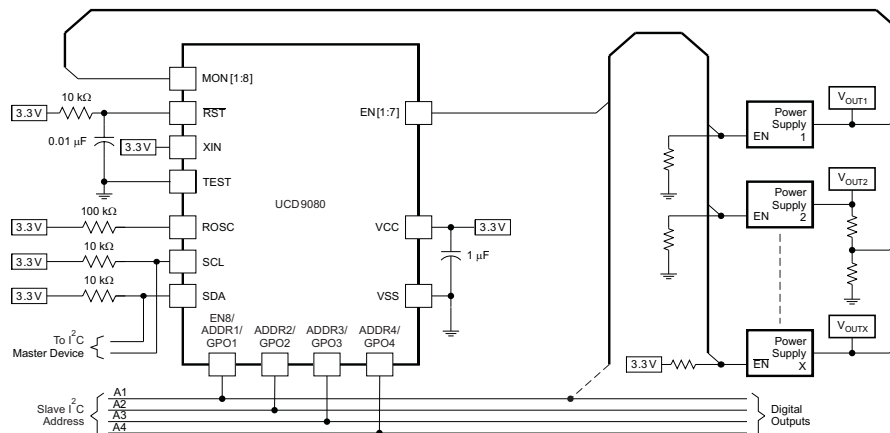

Figure 1. Typical Application Diagram



Please be aware that an important notice concerning availability, standard warranty, and use in critical applications of Texas Instruments semiconductor products and disclaimers thereto appears at the end of this data sheet.

TMS320 is a trademark of Texas Instruments.

Microsoft, Windows are registered trademarks of Microsoft Corporation.

All other trademarks are the property of their respective owners.



These devices have limited built-in ESD protection. The leads should be shorted together or the device placed in conductive foam during storage or handling to prevent electrostatic damage to the MOS gates.

ORDERING INFORMATION

For the most current package and ordering information, see the Package Option Addendum at the end of this document, or see the TI Web site at www.ti.com.

ABSOLUTE MAXIMUM RATINGS⁽¹⁾

	VALUE	UNIT
Voltage applied from VCC to VSS	–0.3 to 4.1	V
Voltage applied to any pin ⁽²⁾	–0.3 to V _{CC} + 0.3	V
Diode current at any device terminal	±2	mA
T _{stg} Storage temperature	–40 to 85	°C

- (1) Stresses beyond those listed under *absolute maximum ratings* may cause permanent damage to the device. These are stress ratings only and functional operation of the device at these or any other conditions beyond those indicated under *recommended operating conditions* is not implied. Exposure to absolute-maximum-rated conditions for extended periods may affect device reliability.
- (2) All voltages referenced to VSS.

RECOMMENDED OPERATING CONDITIONS

	MIN	NOM	MAX	UNIT	
V _{CC}	Supply voltage during operation	3	3.3	3.6	V
	Supply voltage during configuration changes	3	3.3	3.6	
T _A	Operating free-air temperature range	–40		85	°C

ELECTRICAL CHARACTERISTICS

These specifications are over recommended ranges of supply voltage and operating free-air temperature, unless otherwise noted

PARAMETER	TEST CONDITIONS	MIN	NOM	MAX	UNIT
SUPPLY CURRENT					
I _S	Supply current into V _{CC} , excluding external current T _A = 25°C		3	4	mA
I _C	Supply current during configuration 3.6 V	3		7	mA
STANDARD INPUTS (RST, TEST)					
V _{IL}	Low-level input voltage V _{CC} = 3 V		V _{SS}	V _{SS} + 0.6	V
V _{IH}	High-level input voltage V _{CC} = 3 V	0.8 V _{CC}		V _{CC}	V
SCHMITT TRIGGER INPUTS (SDA, SCL, EN1, EN2, EN3, EN4, EN5, EN6, EN7, EN8/ADDR1, ADDR2, ADDR3, ADDR4)					
V _{IT+}	Positive-going input threshold voltage V _{CC} = 3 V	1.5		1.9	V
V _{IT–}	Negative-going input threshold voltage V _{CC} = 3 V	0.9		1.3	V
V _{hys}	Input-voltage hysteresis, (V _{IT+} – V _{IT–}) V _{CC} = 3 V	0.5		1	V
I _{lkg}	High-impedance leakage current			±50	nA

ELECTRICAL CHARACTERISTICS (continued)

These specifications are over recommended ranges of supply voltage and operating free-air temperature, unless otherwise noted

PARAMETER		TEST CONDITIONS	MIN	NOM	MAX	UNIT		
ANALOG INPUTS (MON1, MON2, MON3, MON4, MON5, MON6, MON7, MON8, ROSC)								
V_{CC}	Analog supply voltage	$V_{SS} = 0\text{ V}$	3		3.6	V		
$V_{(R<1..8>)}$	Analog input voltage	Internal voltage reference	0		2.5	V		
		External voltage reference ($V_{CC} = 3.3\text{ V}$ used as reference)	0		V_{CC}			
$C_I^{(1)}$	Input capacitance	Only one terminal can be selected at a time (MON1–MON8)			27	pF		
$R_I^{(1)}$	Input MUX ON resistance	$0\text{ V} \leq V_{(MONx)} \leq V_{CC}$, $V_{CC} = 3\text{ V}$			2000	Ω		
I_{lkg}	High-impedance leakage current	MON1–MON8			± 50	nA		
VREF+	Positive internal reference voltage output	REF2_5V = 1 for 2.5 V $I_{(VREF+)} \leq I_{(VREF+),max}$, $V_{CC} = 3\text{ V}$	2.35	2.5	2.65	V		
$V_{CC(min)}$	VCC minimum voltage, positive built-in reference active	REF2_5V = 1, $I_{(VREF+)} \leq 0.5\text{ mA}$	3			V		
		REF2_5V = 1, $I_{(VREF+)} \leq 1\text{ mA}$	3			V		
$V_{(acc)}$	Accuracy of voltage sampling from rails	Internal reference (2.5 V)	± 6.8	± 12	± 17.4	mV		
		External reference (3.3 V/ V_{CC})	± 0.2	± 1.6	± 6.8			
$T_{REF+}^{(1)}$	Temperature coefficient of built-in reference	$I_{(VREF+)}$ is a constant in the range of $0\text{ mA} \leq I_{(VREF+)} \leq 1\text{ mA}$, $V_{CC} = 3\text{ V}$			± 100	ppm/ $^{\circ}\text{C}$		
MISCELLANEOUS								
$t_{retention}$	Retention of configuration parameters	$T_J = 25^{\circ}\text{C}$	100			Years		
POR, Brownout, Reset ^{(2) (3)}								
$t_{d(BOR)}$	Brownout	$V_{CC}/dt \leq 3\text{ V/s}$			2000	μs		
$V_{CC(start)}$					$0.7 \times V_{(B_IT-)}$		V	
$V_{(B_IT-)}$						1.71	V	
$V_{hys(B_IT-)}$					70	130	180	mV
$t_{(reset)}$				Pulse length needed at RST pin to accept reset internally, $V_{CC} = 3\text{ V}$	2			μs
DIGITAL OUTPUTS (EN8/GPO1, GPO2, GPO3, GPO4, EN1, EN2, EN3, EN4, EN5, EN6, EN7, SDA, SCL)								
V_{OH}	High-level output voltage	$I_{OH(max)} = -1.5\text{ mA}$, ⁽⁴⁾ $V_{CC} = 3\text{ V}$	$V_{CC} - 0.25$		V_{CC}	V		
		$I_{OH(max)} = -6\text{ mA}$, ⁽⁵⁾ $V_{CC} = 3\text{ V}$	$V_{CC} - 0.6$		V_{CC}			
V_{OL}	Low-level output voltage	$I_{OH(max)} = -1.5\text{ mA}$, ⁽⁴⁾ $V_{CC} = 3\text{ V}$	V_{SS}		$V_{SS} + 0.25$	V		
		$I_{OH(max)} = -6\text{ mA}$, ⁽⁵⁾ $V_{CC} = 3\text{ V}$	V_{SS}		$V_{SS} + 0.6$			
I_{lkg}	High-impedance leakage current	$V_{CC} = 3\text{ V}$			± 50	nA		

(1) Not production tested. Limits verified by design.

(2) The current consumption of the brownout module is already included in the I_{CC} current-consumption data.

(3) During power up, device initialization starts subsequent to a period of $t_{d(BOR)}$ after $V_{CC} = V_{(B_IT-)} + V_{hys(B_IT-)}$.

(4) The maximum total current, $I_{OH,max}$ and $I_{OL,max}$, for all outputs combined, should not exceed $\pm 12\text{ mA}$ to hold the maximum voltage drop specified.

(5) The maximum total current, $I_{OH,max}$ and $I_{OL,max}$, for all outputs combined, should not exceed $\pm 48\text{ mA}$ to hold the maximum voltage drop specified.

The UCD9080 is compatible with 3.3-V IO ports of microcontrollers, TMS320™ DSP family as well as ASICs. The UCD9080 is available in a plastic 32-pin QFN package (RHB).

DIGITAL OUTPUTS (Only One Output Loaded at a Time)

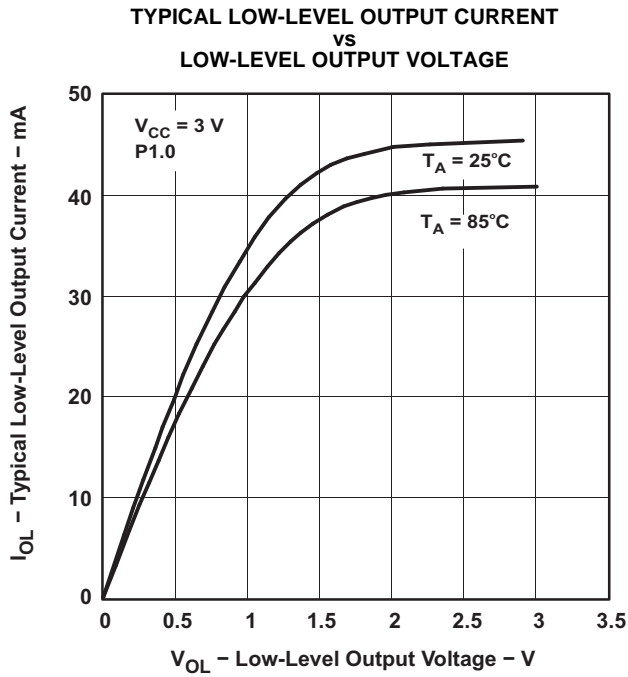

Figure 2.

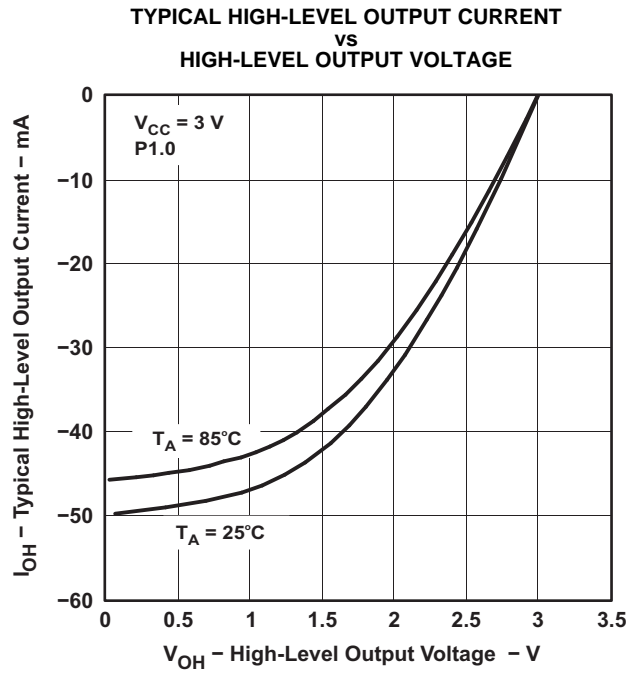

Figure 3.

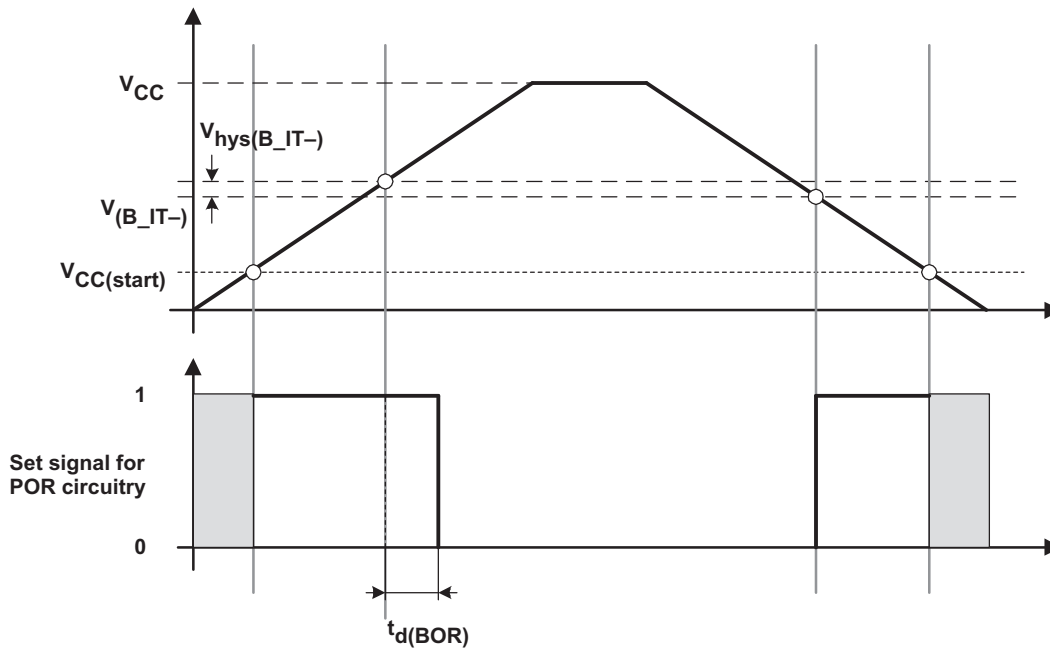

Figure 4. POR/Brownout Reset (BOR) vs Supply Voltage

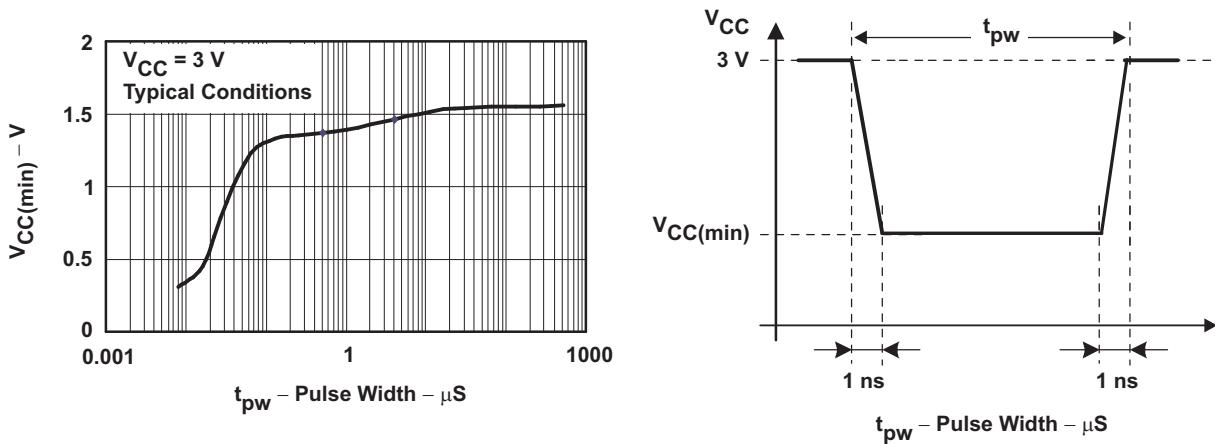

Figure 5. $V_{CC(min)}$ Level With a Square Voltage Drop to Generate a POR/Brownout Signal

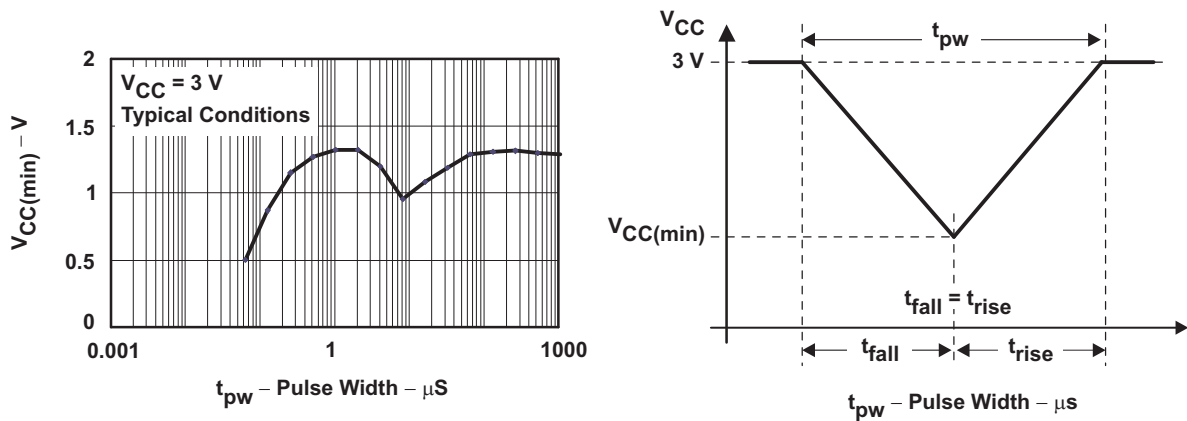

Figure 6. $V_{CC(min)}$ Level With a Triangle Voltage Drop to Generate a POR/Brownout Signal

I²C TIMING

The UCD9080 supports the same timing parameters as standard-mode I²C. See the following timing diagram and timing parameters for more information.

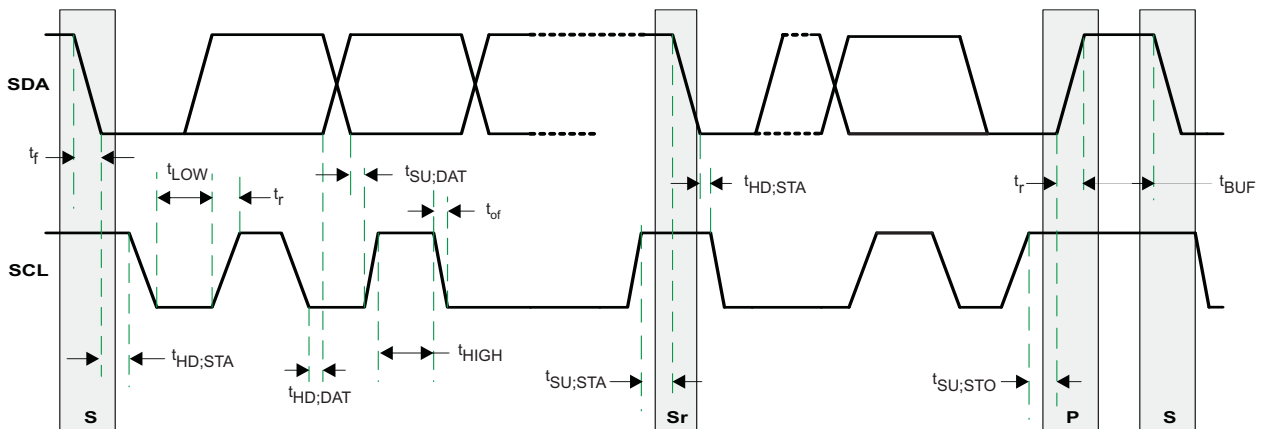

Figure 7. Timing Diagram for I²C Interface

TIMING PARAMETERS FOR I²C INTERFACE

PARAMETER		MIN	MAX	UNIT
t_{of}	Output fall time from V_{OH} to V_{OL} ⁽¹⁾ with a bus capacitance from 10 pF to 400 pF		250 ⁽²⁾	ns
C_I	Capacitance for each pin.		10	pF
f_{SCL}	SCL clock frequency	10	100	kHz
$t_{HD,STA}$	Hold time (repeated) START condition. After this period, the first clock pulse is generated.	4		μs
$t_{HD,DAT}$	Data hold time	0 ⁽³⁾	3.45 ⁽⁴⁾	μs
t_{LOW}	LOW period of the SCL clock	4.7		μs
t_{HIGH}	HIGH period of the SCL clock	4		μs
$t_{SU,STA}$	Set-up time for repeated start condition	4.7		μs
$t_{SU,DAT}$	Data setup time	250		ns
t_r	Rise time of both SDA and SCL signals		1000	ns
t_f	Fall time of both SDA and SCL signals		300	ns
$t_{SU,STO}$	Setup time for STOP condition	4		μs
t_{BUF}	Bus free time between a STOP and START condition	4.7		μs
$C_{(b)}$	Capacitive load for each bus line		400	pF
V_{nL}	Noise margin at the LOW level for each connected device (including hysteresis)	0.1 VDD		V
V_{nH}	Noise margin at the HIGH level for each connected device (including hysteresis)	0.2 VDD		V

- (1) See the *Electrical Characteristics* section of this data sheet.
- (2) The maximum t_f for the SDA and SCL bus lines (300 ns) is longer than the specified maximum t_{of} for the output stages (250 ns). This allows series protection resistors (R_s) to be connected between the SDA/SCL pins and the SDA/SCL bus lines without exceeding the maximum specified t_f .
- (3) A device must internally provide a hold time of at least 300 ns for the SDA signal to bridge the undefined region of the falling edge of SCL.
- (4) The maximum $t_{HD,DAT}$ must only be met if the device does not stretch the LOW period (t_{LOW}) of the SCL signal.

**RHB PACKAGE
(TOP VIEW)**

Table 1. TERMINAL FUNCTIONS

TERMINAL		I/O	DESCRIPTION
NAME	NO.		
ADDR2/GPO2	26	I/O	I ² C address select 2, general-purpose digital output 2
ADDR3/GPO3	27	I/O	I ² C address select 3, general-purpose digital output 3
ADDR4/GPO4	28	I/O	I ² C address select 4, general-purpose digital output 4
EN1	23	I/O	Voltage rail 1 enable (digital output)
EN2	24	I/O	Voltage rail 2 enable (digital output)
EN3	11	I/O	Voltage rail 3 enable (digital output)
EN4	10	I/O	Voltage rail 4 enable (digital output)
EN5	12	I/O	Voltage rail 5 enable (digital output)
EN6	13	I/O	Voltage rail 6 enable (digital output)
EN7	14	I/O	Voltage rail 7 enable (digital output)
EN8/ADDR1/ GPO1	25	I/O	Voltage rail 8 enable (digital output), I ² C address select 1, general-purpose digital output 1
MON1	6	I	Analog input for voltage rail 1
MON2	7	I	Analog input for voltage rail 2
MON3	8	I	Analog input for voltage rail 3
MON4	18	I	Analog input for voltage rail 4
MON5	19	I	Analog input for voltage rail 5
MON6	9	I	Analog input for voltage rail 6
MON7	15	I	Analog input for voltage rail 7
MON8	16	I	Analog input for voltage rail 8
NC	2		Do not connect.
NC	4,17, 20, 31		Not connected internally. Connect to VSS.
ROSC	32		Internal oscillator frequency adjust. Must use 100-k Ω pullup to VCC for minimum drift and maximum frequency when sampling voltage rails.
RST	5	I	Reset input
SCL	22	I/O	I ² C clock. A pullup resistor to 3.3 V is required.
SDA	21	I/O	I ² C data (bidirectional). A pullup resistor to 3.3 V is required.
TEST	29	I	Connect to VSS
VCC	30		Supply voltage
VSS	1		Ground reference
XIN	3		Connect to VCC

FUNCTIONAL BLOCK DIAGRAM

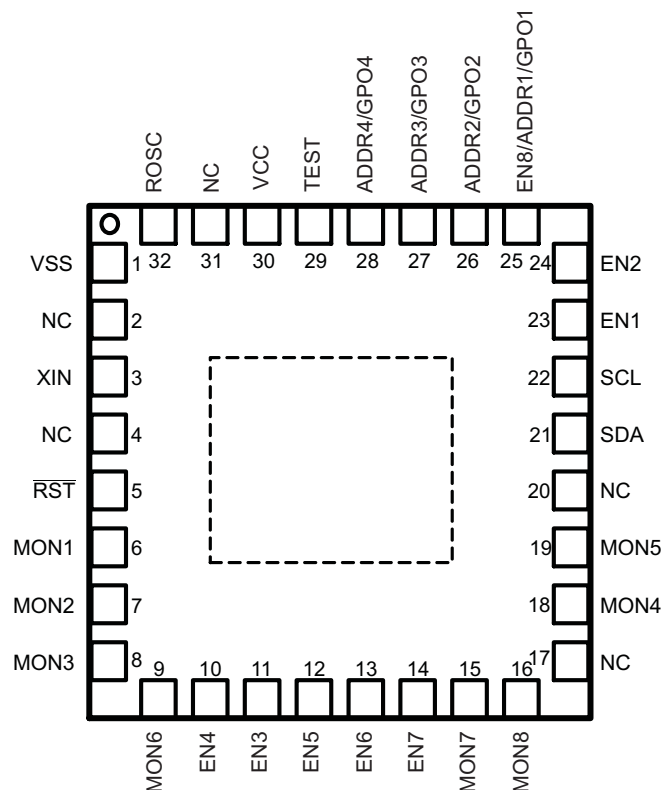
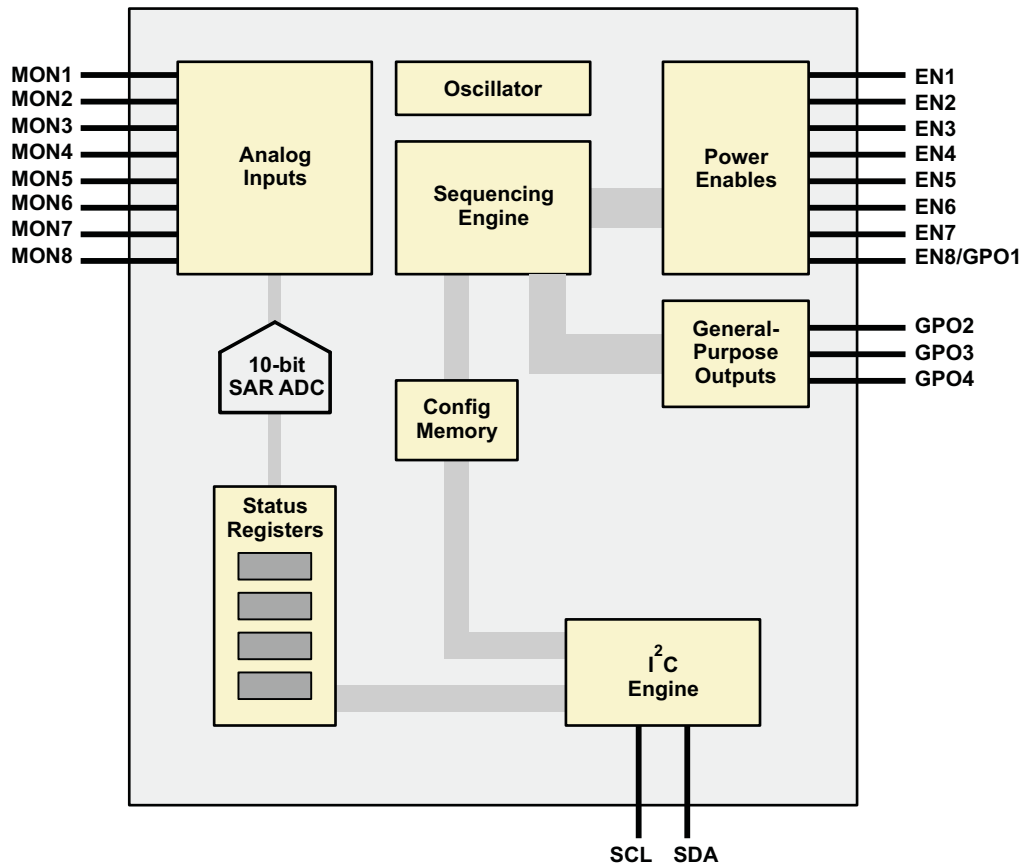

FUNCTIONAL DESCRIPTION

POWER-SUPPLY SEQUENCING

The UCD9080 can be configured to sequence the power rails using the enable signals or the general-purpose outputs in one of three ways.

The first way is to specify a delay time after a UCD9080 RESET. The enable/GPO is asserted after the UCD9080 RESET plus a specified delay.

The second way is to specify a delay time after another (parent) rail has achieved regulation (that is, V_{RAIL} is within the specified under- and overvoltage settings). The enable/GPO is asserted after the (parent) rail is in regulation plus specified delay.

The third way is to specify a (parent) rail voltage. The enable/GPO is asserted after the (parent) rail voltage is greater than or equal to the specified voltage.

Of course, a rail does not have to be sequenced, as in the case of a backplane voltage that is not under the control of the UCD9080, but is being monitored.

POWER-SUPPLY ENABLES

The UCD9080 can sequence up to eight power supplies using the ENx (EN1 to EN8) signals. These signals can be configured as active-high or active-low, supporting power supplies with either polarity.

EN8 can also be configured as a GPO (GPO1). EN8/ADDR1/GPO1 is also used for I²C address selection (ADDR1).

GENERAL-PURPOSE OUTPUTS

The UCD9080 can control up to four general-purpose digital outputs using the same sequencing mechanisms as described in the [Power-Supply Enables](#) section. These general-purpose outputs (referred to as GPO1–GPO4) can be used for digital signals such as RESET or status. Note that these signals are multiplexed with other functions (primarily I²C address selection). See the [Terminal Functions](#) table to ensure that these signals are used properly by the application. Also note that the GPO1 signal is multiplexed with EN8, so both of these cannot be used at the same time.

EXTERNAL CONSIDERATIONS FOR EN AND GPO PINS

During the UCD9080 RESET interval, all ENx and GPOx pins become Schmitt-trigger Inputs. A UCD9080 RESET occurs under the following conditions:

- External \overline{RST} pin is driven low.
- Power is applied to the device (power-on reset) or power is cycled.
- A sequence event occurs as a result of a configured rail-alarm event.
- The RESTART register is written with a value of 0 over the I²C bus.

All ENx and GPOx pins must be externally terminated to one of the following Schmitt-trigger input-logic states for proper sequencer operation.

- EN or GPO pin configured for ACTIVE-LOW polarity: the external resistor network must default the corresponding EN or GPO pin to a voltage greater than or equal to 1.9 V (V_{IT+} , MAX, positive-going input threshold voltage) during device reset.
- EN or GPO pin configured for ACTIVE-HIGH polarity: the external resistor network must default the corresponding EN or GPO pin to a voltage less than or equal to 0.9 V (V_{IT-} , MIN, negative-going input threshold voltage) during device reset.

NOTE:

The external resistor networks should not derive their voltage from a sequenced power supply, as this may cause the voltage level presented to the ENx or GPOx pin to be at the wrong level during device reset. It is best to use the UCD9080 VCC supply for the external resistor networks.

UCD9080

SLVS692E – SEPTEMBER 2006 – REVISED MAY 2008

www.ti.com

The user must consider GPO polarity usage when programming the UCD9080 I²C address using the external GPOx (ADDRx) resistor networks. Acceptable ADDRx bit voltage levels are set according to Schmitt-trigger input specifications. The following GPOx/ADDRx combinations are acceptable:

- GPOx = Active-low polarity: Corresponding ADDRx bit set to Schmitt-trigger input logic level = 1
- GPOx = Active-high polarity: Corresponding ADDRx bit set to Schmitt-trigger input logic level = 0

VOLTAGE REFERENCE

The UCD9080 has a voltage reference that is selectable via the I²C interface and parameter configuration section. The voltage reference can either be an internally generated 2.5-V reference or an external 3.3-V reference. If the external voltage reference is selected, then the 3.3-V reference is from the V_{CC} supply to the UCD9080.

Depending on the voltage reference that is being used, the accuracy of reading voltages is affected. The internal reference is not as accurate as the external reference and affects the accuracy of the sampled voltages of the monitored rails. See the *Electrical Characteristics* for information on voltage reading accuracy for use with each of the references.

The [Configuring the UCD9080](#) section details how to select the internal or external voltage reference.

VOLTAGE MONITORING

The UCD9080 can monitor eight voltage rails through the MONx terminals of the device (MON1–MON8). The UCD9080 samples these eight input channels using either the internal 2.5-V reference or V_{CC} (3.3 V) as a voltage reference to convert the voltage to digital values. The eight digitally monitored voltage values are accessible via the I²C interface.

When monitoring a voltage rail that has a nominal voltage larger than 2.5 V (internal reference) or 3.3 V (external reference), a resistor divider network is typically used. The design must ensure that the source impedance of that resistor network is not too high, because it causes the UCD9080 analog-to-digital converter (ADC) to take longer to perform the sample-and-hold conversion. The extended conversion time causes the frequency of the sampling of voltage rails to slow below 20 kHz.

Using a higher-valued resistor network lowers the overall power dissipation of the solution, which is desirable. In order to keep the source impedance low, a buffer circuit is typically used. The UCD9080 analog inputs require that a source impedance of less than 20 kΩ be used in order to maintain the high sampling rate of the voltages.

The UCD9080 allows specification of overvoltage threshold, undervoltage threshold, and out-of-regulation or glitch duration for each monitored rail.

Each voltage rail can also be marked so that it is not monitored, in which case all checks and alarm conditions are disabled.

RAIL SHUTDOWN

Rail shutdown is the act of setting the ENx pin associated with that rail to a state which disables the power supply output. Each UCD9080 rail can be configured to shut down based on a monitored alarm event (sustained overvoltage, sustained undervoltage, or rail did not start) and in a configurable manner.

The options for rail shutdown are as follows:

- Ignore
- Log only
- Sequence
- Retry 1 time
- Retry 0 times

If the system does not care whether a monitored rail enters a sustained error condition, the UCD9080 can be configured to either ignore or log the error event and take no subsequent action.

The UCD9080 can also be configured to sequence the entire system in response to a sustained error condition. When the UCD9080 monitors an alarm event on the configured rail, UCD9080 RESET occurs (all ENx and GPOx outputs go to the high-impedance state for ~4–5 ms). Next, a sequence of all configured enables and GPOs occurs, as defined by the current sequencer configuration. Note that for this configuration, a shutdown according to the values in the UnsequenceTime register does not occur prior to UCD9080 RESET.

The UCD9080 can also be configured to attempt to restart a rail once in response to a sustained error condition. When the UCD9080 monitors an alarm event on a configured rail, the rail is momentarily disabled and then re-enabled. The rail remains enabled according to the RampTime register setting (time), and if the rail does not properly achieve regulation, the system (rail and dependent rails) is shut down as defined by the current sequencer configuration (UnsequenceTime register).

The last option that the UCD9080 supports is to shut down (if specified as a dependency) and disable (Retry 0 times) a configured rail in response to a sustained error condition. When the UCD9080 monitors an alarm event on the configured rail, the system (dependent rails and GPOs) is shut down as defined by the current sequencer configuration (UnsequenceTime register). Only rails and GPOs marked as dependencies of the configured rail are shut down. If there are no rails or GPO dependencies marked, the configured rail is just disabled in response to the sustained error condition.

Each UCD9080 ENx and GPOx output can be marked to sequence after shutdown (as defined by the current sequencer configuration) if specified as a dependency in the DependencyMasks register. For example, if rail 1 is configured to sequence after shutdown (RESEQ bit set), and rail 2 has rail 1 set in its dependency mask, then if/when rail 2 is shut down, rail 1 shuts down and the system resequences.

BROWNOUT

The brownout circuit is implemented to provide the proper internal reset signal to the device during power on and power off.

I²C INTERFACE

The UCD9080 power-supply sequencer has a 100-kHz, slave-mode I²C interface for communication with an I²C master. The I²C master uses this interface to configure and monitor the UCD9080.

I²C Address Selection

The UCD9080 supports 7-bit I²C addressing. The UCD9080 selects an I²C address by sampling the logic level of the four digital inputs to the device (ADDR1–ADDR4) during the UCD9080 RESET interval. When the UCD9080 is released from RESET, the ADDR_x logic levels are latched and the I²C address is assigned as shown in [Figure 8](#).

A7 = 1	A6 = 1	A5 = 0	A4 = ADDR4/GPO4	A3 = ADDR3/GPO3	A2 = ADDR2/GPO2	A1 = EN8/ADDR1/GPO1
--------	--------	--------	-----------------	-----------------	-----------------	---------------------

Figure 8. I²C ADDRESS = 0x60–0x6F

External pullup/pulldown resistors are required to configure the I²C address; the UCD9080 does not have internal bias resistors. Note that the 7-bit I²C address refers to the address bits only, not the read/write (8th) bit in the first byte of the I²C protocol. The base I²C address is 0x60 and the I²C general-call address (0x00) is not supported.

After the initialization process of the UCD9080 is complete, these four pins can be used as general-purpose outputs (GPOs). They can be programmed and sequenced as described in the [Configuring the UCD9080](#) section. GPO polarity must consider the external I²C address resistors as described in the [External Considerations for EN and GPO Pins](#) section.

I²C Transactions

The UCD9080 can be configured and monitored via I²C memory-mapped registers. Registers that are configurable (can be written) via an I²C write operation are implemented using an I²C unidirectional data transfer, from the master to slave, with a stop bit between transactions.

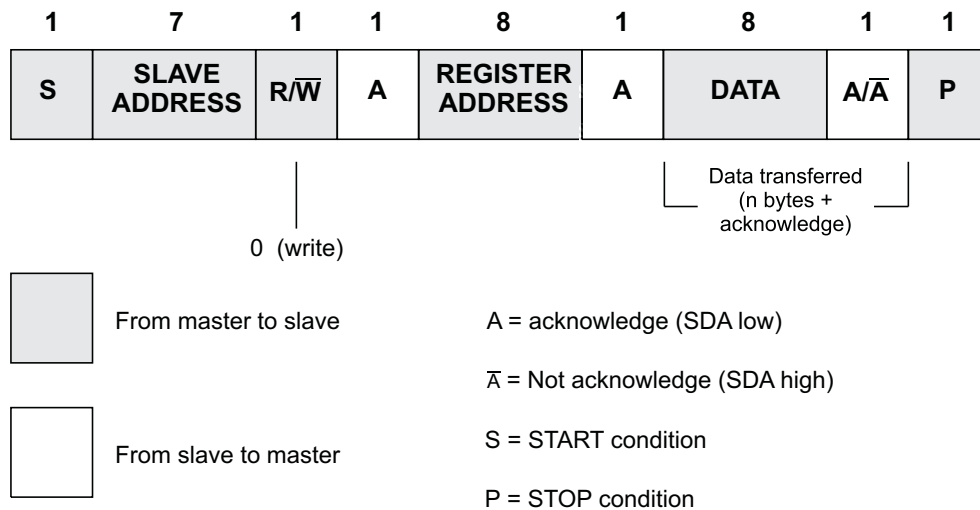
I²C Unidirectional Transfer

Figure 9. I²C Register Access With START/STOP

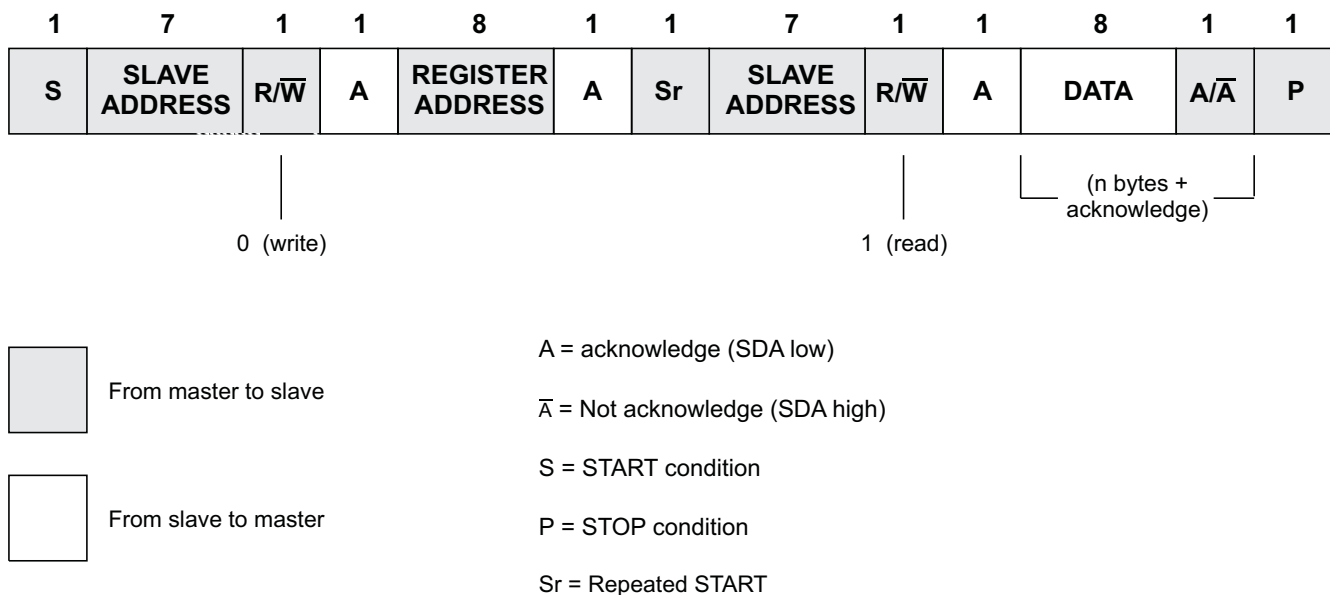
Registers that can be read are implemented using an I²C read operation, which uses the I²C combined format that changes data direction during the transaction. This transaction uses an I²C repeated START during the direction change.

I²C Combined Format

Figure 10. I²C Register Access With Repeated START

The UCD9080 also supports a feature that auto-increments the register address pointer for increased efficiency when accessing sequential blocks of data. It is not necessary to issue separate I²C transactions.

CONFIGURING AND MONITORING THE UCD9080

The UCD9080 supports both configuration and monitoring using its I²C slave interface. A Microsoft Windows GUI is available for configuring and monitoring the UCD9080. See the *UCD9080 Power Supply Sequencer and Monitor EVM* user's guide ([SLVU184](#)).

For monitoring the sequencer, an I²C memory map allows an I²C host to perform memory-mapped reads (and in some cases writes) to obtain status information from the UCD9080. For instance, all rails can report their voltage through the I²C memory map. For information on which parameters are available via the I²C memory map, see the [Monitoring the UCD9080](#) section.

To change configuration parameters of the sequencer, a different mechanism is used. The entire set of configuration parameters must be written to the device at one time as one large transaction over the I²C interface to ensure that the configuration of the device is consistent at any given time. The process for configuring the UCD9080 is described in the [Configuring the UCD9080](#) section.

MONITORING THE UCD9080

Register Map

The UCD9080 allows all monitoring of the system through the I²C interface on the device. The following is the memory map of the supported registers in the system. The detail of each of these registers is given in the next section as well.

Note that the UCD9080 supports functionality to increment the I²C register address value automatically when a register is being accessed, to access blocks of like registers more efficiently. The following table also shows the amount that the register address is incremented for each register access.

REGISTER NAME	ADDRESS	ACCESS	ADJUSTMENT AFTER ACCESS
RAIL1H	0x00	r	+1 (0x01)
RAIL1L	0x01	r	+1 (0x02)
RAIL2H	0x02	r	+1 (0x03)
RAIL2L	0x03	r	+1 (0x04)
RAIL3H	0x04	r	+1 (0x05)
RAIL3L	0x05	r	+1 (0x06)
RAIL4H	0x06	r	+1 (0x07)
RAIL4L	0x07	r	+1 (0x08)
RAIL5H	0x08	r	+1 (0x09)
RAIL5L	0x09	r	+1 (0x0A)
RAIL6H	0x0A	r	+1 (0x0B)
RAIL6L	0x0B	r	+1 (0x0C)
RAIL7H	0x0C	r	+1 (0x0D)
RAIL7L	0x0D	r	+1 (0x0E)
RAIL8H	0x0E	r	+1 (0x0F)
RAIL8L	0x0F	r	-15 (0x00)
ERROR1	0x20	r	+1 (0x21)
ERROR2	0x21	r	+1 (0x22)
ERROR3	0x22	r	+1 (0x23)
ERROR4	0x23	r	+1 (0x24)
ERROR5	0x24	r	+1 (0x25)
ERROR6	0x25	r	-5 (0x20)
STATUS	0x26	r	0 (0x26)
VERSION	0x27	r	0 (0x27)
RAILSTATUS1	0x28	r	+1 (0x29)
RAILSTATUS2	0x29	r	-1 (0x28)
FLASHLOCK	0x2E	rw	0 (0x2E)
RESTART	0x2F	w	0 (0x2F)
WADDR1	0x30	rw	+1 (0x31)
WADDR2	0x31	rw	-1 (0x30)

UCD9080

SLVS692E – SEPTEMBER 2006 – REVISED MAY 2008

www.ti.com

REGISTER NAME	ADDRESS	ACCESS	ADJUSTMENT AFTER ACCESS
WDATA1	0x32	rw	+1 (0x33)
WDATA2	0x33	rw	-1 (0x32)

Register Descriptions

The following are the detailed descriptions of each of the UCD9080 I²C registers.

The following register bit conventions are used. Each register is shown with a key indicating the accessibility of each bit, and the initial condition after device initialization.

KEY	ACCESS
rw	Read/write
r	Read-only
r0	Read as 0
r1	Read as 1
w	Write-only
w0	Write as 0
w1	Write as 1
rc	Read clears bit after read
rs	Read sets bit after read
-0, -1	Condition after initialization

RAIL

For each of eight voltage rails, the UCD9080 has two registers that contain the rolling average voltage for the associated rail as measured by the device. This average voltage is maintained in real-time by the UCD9080 and is calculated as the output of a 4-TAP FIR filter. There are two registers for each voltage rail. One holds the least-significant 8 bits of the voltage and the other the most-significant 2 bits of the voltage. This is shown in the following table.

Register Name	Address	Register Contents
RAIL1H	0x00	RAIL1 voltage, bits 9:8
RAIL1L	0x01	RAIL1 voltage, bits 7:0
RAIL2H	0x02	RAIL2 voltage, bits 9:8
RAIL2L	0x03	RAIL2 voltage, bits 7:0
RAIL3H	0x04	RAIL3 voltage, bits 9:8
RAIL3L	0x05	RAIL3 voltage, bits 7:0
RAIL4H	0x06	RAIL4 voltage, bits 9:8
RAIL4L	0x07	RAIL4 voltage, bits 7:0
RAIL5H	0x08	RAIL5 voltage, bits 9:8
RAIL5L	0x09	RAIL5 voltage, bits 7:0
RAIL6H	0x0A	RAIL6 voltage, bits 9:8
RAIL6L	0x0B	RAIL6 voltage, bits 7:0
RAIL7H	0x0C	RAIL7 voltage, bits 9:8
RAIL7L	0x0D	RAIL7 voltage, bits 7:0
RAIL8H	0x0E	RAIL8 voltage, bits 9:8
RAIL8L	0x0F	RAIL8 voltage, bits 7:0

A rail voltage is read with a 16-bit access. The auto-increment feature of the UCD9080 allows multiple rail voltages to be read with a single access.

A rail voltage is provided as a 10-bit value in an unsigned format:

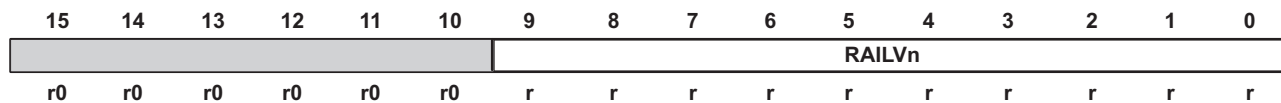

The following formulas can be used to calculate the actual measured rail voltage:

Without external voltage divider:

$$V_{\text{RAILn}} = \frac{\text{RAILVn}}{1024} \times V_{\text{REF}} \quad (1)$$

With external voltage divider:

$$V_{\text{RAILn}} = \frac{\text{RAILVn}}{1024} \times V_{\text{REF}} \times \frac{R_{\text{PULLDOWN}} + R_{\text{PULLUP}}}{R_{\text{PULLDOWN}}} \quad (2)$$

UCD9080

SLVS692E – SEPTEMBER 2006 – REVISED MAY 2008

www.ti.com

ERROR

Error conditions are logged by the UCD9080 and are accessible to the user via reading the ERROR register. This is a 6-byte register with the following format:

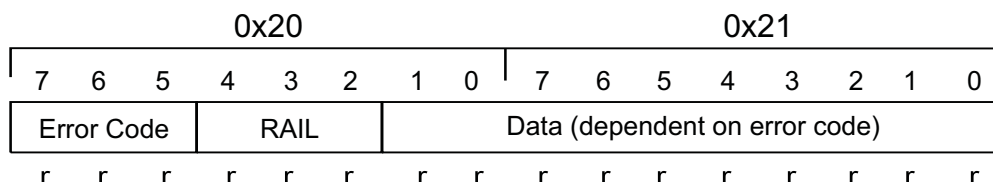

RAIL	Meaning	Rail #(n) – 1, RAIL = 0 through 7
-------------	----------------	-----------------------------------

Error Codes	Meaning	Data
0 0 0	Null alarm	0x0000
0 0 1	Supply did not start	Average voltage on rail
0 1 0	Sustained overvoltage detected	Average voltage on rail
0 1 1	Sustained undervoltage detected	Average voltage on rail
1 0 0	Overvoltage glitch detected	Glitch voltage level on rail
1 0 1	Undervoltage glitch detected	Glitch voltage level on rail
1 1 0	Reserved	Reserved
1 1 1	Reserved	Reserved

NOTE: When error code = *Null Alarm*, then the Hours, Minutes, Seconds, and Milliseconds fields are zero.

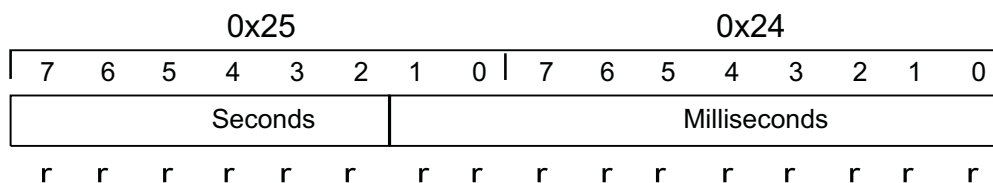
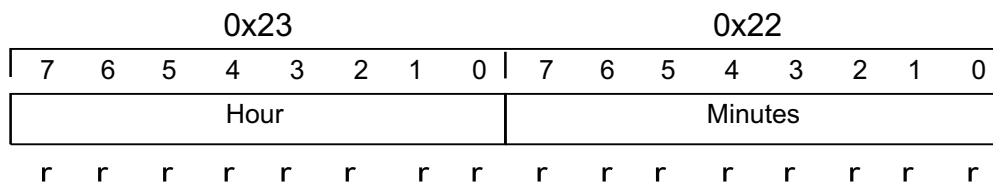

Error conditions encountered during processing post error logs to this register with some exceptions. This register is internally managed as a FIFO (with a depth of 8). Errors are posted to the FIFO as they occur, and read out of the FIFO via I²C access. Due to the unknown latency of host extraction of the FIFO data, the UCD9080 only posts to the FIFO if there is room to write. There is no real-time impact to processing in the UCD9080 if this FIFO is full and cannot be posted to.

The values in registers 0x22 through 0x25 are reset to a value of 0 during UCD9080 RESET.

STATUS

STATUS is an 8-bit read-only register. This register provides real-time status information about the state of the UCD9080. The following bits are defined.

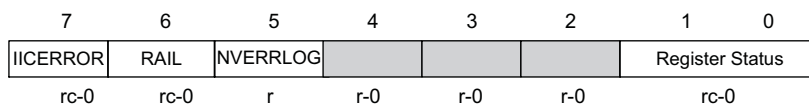

IICERROR Meaning

- 0 No I²C PHY layer error
- 1 I²C PHY layer error

RAIL Meaning

- 0 No RAIL error pending
- 1 RAIL error pending

NVERRLOG: Reserved

Register

- | Status | Meaning |
|--------|--------------------|
| 00 | No error |
| 01 | Invalid address |
| 10 | Read access error |
| 11 | Write access error |

Reading of the STATUS register clears the register except for the NVERRLOG bit, which is maintained until the device is reset. Descriptions of the different errors follow.

The IICERROR bit is set when an I²C access fails. This is most often a case where the user has accessed an invalid address or performed an illegal number of operations for a given register (for example, reading 3 bytes from a 2-byte register). In the event of an I²C error when IICERROR is set, bits 1:0 of the STATUS register further define the nature of the error as shown in the preceding figure.

The RAIL error bit is set to alert the user to an issue with one of the voltage rails. When this bit is set, the user is advised to query the RAILSTATUS register to further ascertain which RAIL input(s) have an issue. The user may then query the ERROR registers to get further information about the nature of the error condition.

The NVERRLOG bit is reserved for future use.

When the IICERROR bit is set, the register status bits provide further information about the type of I²C error that has been detected, as indicated previously.

RAILSTATUS

The RAILSTATUS1 and RAILSTATUS2 registers are two 8-bit read-only registers that provide a bit mask to represent the error status of the rails as indicated in the following diagram. The RAILSTATUS1 register is reserved.

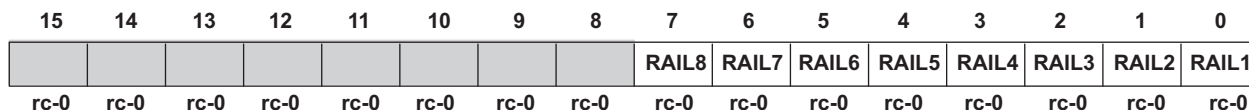

RAILn Meaning

- 0 No alarm pending for RAILn
- 1 Alarm pending for RAILn

Bits 15:8 are RAILSTATUS1 and bits 7:0 are RAILSTATUS2. These are read as two 8-bit registers or as a single 16-bit register.

If a bit is set in these registers, then the ERROR register is read to further ascertain the specific error. Bits in the RAILSTATUS1 and RAILSTATUS2 registers are cleared when read.

UCD9080

SLVS692E – SEPTEMBER 2006 – REVISED MAY 2008

www.ti.com

FLASHLOCK

The FLASHLOCK register is used to lock and unlock the configuration memory on the UCD9080 when updating the configuration. The [Configuring the UCD9080](#) section details this process.

The format for the FLASHLOCK register is as follows:

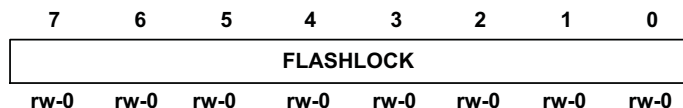

FLASHLOCK

- 0x00** Lock flash (default)
- 0x01** Flash is being updated
- 0x02** Unlock flash (before configuration)

RESTART

The RESTART register provides the capability for the I²C host to force a re-initialization and restart of the UCD9080. This is an 8-bit register, and when a value of 0 is written to the register, the UCD9080 is restarted and the rails are resequenced.

Note that in order to respond to this I²C request properly, there is a 50- μ s delay before the system is restarted, so that the I²C ACK can take place.

WADDR and WDATA

In order to update the configuration on the UCD9080, four registers are provided: WADDR2 (address bits 8–15), WADDR1 (address bits 0–7), WDATA2 (data bits 8–15), and WDATA1 (data bits 0–7). WADDR2 and WADDR1 specify the 16-bit memory address and WDATA2 and WDATA1 specify the 16-bit data written to or read from that memory address.

The format for the WADDR register is as follows:

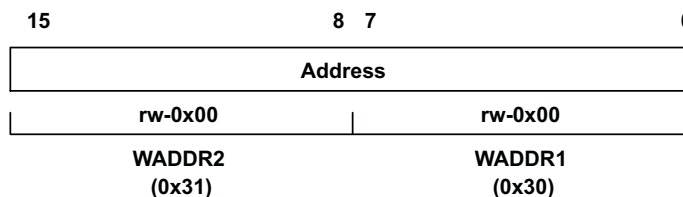

To set the address of the memory that will be accessed, write the LSB of the address to the WADDR1 register and the MSB of the address to the WADDR2 register. For example, to write the address 0x1234 to the device, set WADDR1 = 0x34 and WADDR2 = 0x12. Note that because these addresses support the auto-increment feature, the user can perform a single 16-bit write to WADDR1 to write the entire address.

The format for the WDATA register is as follows:

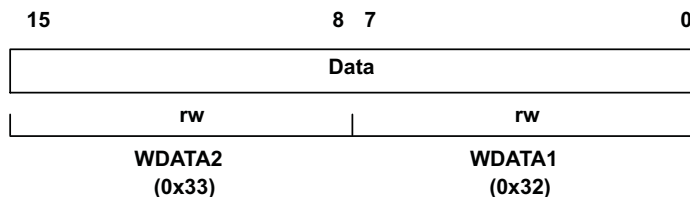

To set the value of the data that will be written, write the LSB of the data to the WDATA1 register and the MSB of the data to the WDATA2 register. For example, to write the data 0xBEEF to the device, set WDATA1 = 0xEF and WDATA2 = 0xBE. Note that because these addresses support the auto-increment feature, the user can perform a single 16-bit write to WDATA1 to write the entire data. To read the value of the data at the specified address, read the LSB from WDATA1 and the MSB from WDATA2.

These registers are used for updating the UCD9080 configuration as explained in the [Configuring the UCD9080](#) section.

CONFIGURING THE UCD9080

The UCD9080 has many different configurable parameters, such as sequencing policies, shutdown policies and dependency masks. The UCD9080 can configure all of its parameters via the I²C interface while the device is operational. Sequencing, shutdown, and rail monitoring are not performed during device configuration time.

NOTE:

During runtime, if the UCD9080 is configured, there is a delay in voltage monitoring while the new configuration parameters are applied to the device.

To configure the UCD9080, a large block of configuration information is sent to the device via the I²C interface. This block is 512 bytes and contains all the configuration information that the device requires for any function of the UCD9080.

This 512-byte block of configuration information is sent to the device in multiple segments. The segment size can range from 2 to 32 bytes at one time, and must be a power of 2 bytes. That is, a master can send 256 2-byte segments or 32 16-byte segments, and so on. All the segments must be sent back-to-back in the proper sequence, and this operation must be completed by sending the last segment so that the last byte of the 512-byte block is written. If this is not done, the UCD9080 is in an unknown state and does not function as designed.

The process for sending the configuration information to the UCD9080 is as shown in [Figure 11](#):

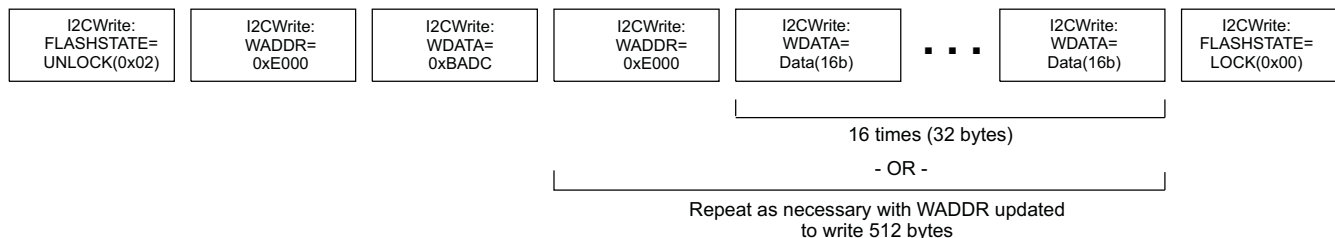

Figure 11. Configuration Information

As shown in [Figure 11](#), the process for updating the configuration of the UCD9080 is as follows:

1. Unlock flash memory by writing the FLASHLOCK register with a value of 0x02.
2. Write the address of the configuration section of memory (WADDR = 0xE000).
3. Write the constant 0xBADC to update memory (WDATA = 0xBADC).
4. Write the address of the configuration section of memory again (WADDR = 0xE000).

5. Write the data (WDATA = <varies>). Repeat steps 4 and 5 as necessary, depending on the data segment size used, to write 512 bytes. Increment the address as necessary.
6. Lock flash memory after the last byte of the last segment is written by writing the FLASHLOCK register with a value of 0x00.

At the conclusion of this process, the configuration of the UCD9080 is updated with the configuration changes, as represented by the values from the data segments. The UCD9080 can then be reset by writing the RESTART register with a value of 0. The new sequencer configuration then starts.

The memory map for the 512-byte configuration segment is defined in the [Configuration Parameters Detail](#) section.

User Data

User data (128 bytes) can be stored in the UCD9080 user-data area at memory location 0x1080 to 0x10FF. Access to the user-data area occurs by following the procedure outlined in the [Configuring the UCD9080](#) section.

Configuration Parameters Memory Map

Table 2 shows the 512-byte configuration parameters memory map. User-configurable bytes in bold are described in the [Configuration Parameters Detail](#) section; adjacent groups of user-configurable bytes are distinguished in the table by alternating use of italics. **Other bytes must remain exactly as shown in Table 2.**

Table 2. Configuration Parameters Memory Map

ADDRESS	+0	+1	+2	+3	+4	+5	+6	+7
0xE000	0x00	0x00	0x00	0x00	0x00	0x00	0x00	0x00
0xE008	0x00	0x00	0x00	0x00	0x00	0x00	0x00	0x00
0xE010	0x00	0x00	0x00	0x00	0x00	0x00	0x00	0x00
0xE018	0x00	0x00	0x00	0x00	0x00	0x00	0x00	0x00
0xE020	0x00	0x00	0x00	0x00	0x00	0x00	0x00	0x00
0xE028	0x00	0x00	0x00	0x00	0x00	0x00	0x00	0x00
0xE030	0x00	0x00	0x00	0x00	0x00	0x00	0x00	0x00
0xE038	0x00	0x00	0x00	0x00	0x00	0x00	0x00	0x00
0xE040	0x00	0x00	0x00	0x00	0x00	0x00	0x00	0x00
0xE048	0xFF	0xFF	0x00	0x00	0x00	0x00	0x00	0x00
0xE050	0x00	0x00	0x00	0x00	0x00	0x00	0x00	0x00
0xE058	0xFF	0x00	0x00	0x00	0x00	0x00	0xC0	0x02
0xE060	0x00	0x00	0x00	0x0F	0x00	0x02	0x00	0x02
0xE068	0xFF	0x0F	0x00	0x50	0x00	0x00	0x00	0x00
0xE070	0x00	0x00	0xC0	0x20	0x00	0x00	0x00	0x00
0xE078	0x00	0x00	0x00	0x00	0x00	0xA8	0xDC	0xBA
0xE080	0x50	0x51	0x52	0x53	0x54	0x55	0x56	0x57
0xE088	0x00	0x49	0x4A	0x4B	<i>0x01</i>	<i>0x00</i>	<i>0x01</i>	<i>0x04</i>
0xE090	<i>0x01</i>	<i>0x04</i>	<i>0x05</i>	<i>0x06</i>	<i>0x00</i>	<i>0x00</i>	<i>0x00</i>	<i>0x00</i>
0xE098	0x05	0xE0	0x05	0xA0	0x32	0xE0	0x33	0xE0
0xE0A0	0x33	0xE0	0x35	0xE0	0x35	0xE0	0x00	0x00
0xE0A8	0x00	0x00	0x00	0x00	0x00	0x00	0x00	0x00
0xE0B0	0xFF	0x7F	0xFF	0x7F	0xFF	0x7F	0xFF	0x7F
0xE0B8	0xFF	0x7F	0xFF	0x7F	0xFF	0x7F	0xFF	0x7F
0xE0C0	0x00	0x00	0x00	0x00	0x00	0x00	0x00	0x00
0xE0C8	0x00	0x00	0x00	0x00	0x00	0x00	0x00	0x00
0xE0D0	0x00	0x00	0x00	0x00	0x00	0x00	0x00	0x00
0xE0D8	0x00	0x00	0x00	0x00	0x00	0x00	0x00	0x00
0xE0E0	0x00	0x00	0x00	0x00	0x00	0x00	0x00	0x00

Table 2. Configuration Parameters Memory Map (continued)

ADDRESS	+0	+1	+2	+3	+4	+5	+6	+7
0xE0E8	0x00	0x00	0x00	0x00	0x00	0x00	0x00	0x00
0xE0F0	0x00	0x00	0x00	0x00	0x00	0x00	0x00	0x00
0xE0F8	0x00	0x00	0x00	0x00	0x00	0x00	0x00	0x00
0xE100	0x7F	0x00	0x01	0x00	0x02	0x00	0x04	0x00
0xE108	0x08	0x00	0x10	0x00	0x20	0x00	0x40	0x00
0xE110	<i>0x00</i>	<i>0x00</i>	<i>0x00</i>	<i>0x00</i>	<i>0x00</i>	<i>0x00</i>	<i>0x00</i>	<i>0x00</i>
0xE118	<i>0x00</i>	<i>0x00</i>	<i>0x00</i>	<i>0x00</i>	<i>0x00</i>	<i>0x00</i>	<i>0x00</i>	<i>0x00</i>
0xE120	0x00	0x04	0x00	0x04	0x00	0x04	0x00	0x04
0xE128	0x00	0x04	0x00	0x04	0x00	0x04	0x00	0x04
0xE130	<i>0xA0</i>	<i>0x0F</i>	<i>0xA0</i>	<i>0x0F</i>	<i>0xA0</i>	<i>0x0F</i>	<i>0xA0</i>	<i>0x0F</i>
0xE138	<i>0xA0</i>	<i>0x0F</i>	<i>0xA0</i>	<i>0x0F</i>	<i>0xA0</i>	<i>0x0F</i>	<i>0xA0</i>	<i>0x0F</i>
0xE140	0x10	0x00	0x10	0x00	0x10	0x00	0x10	0x00
0xE148	0x10	0x00	0x10	0x00	0x10	0x00	0x10	0x00
0xE150	<i>0xFF</i>	<i>0xC0</i>	<i>0xFF</i>	<i>0xC1</i>	<i>0xFF</i>	<i>0xC2</i>	<i>0xFF</i>	<i>0xC3</i>
0xE158	<i>0xFF</i>	<i>0xC4</i>	<i>0xFF</i>	<i>0xC5</i>	<i>0xFF</i>	<i>0xC6</i>	<i>0xFF</i>	<i>0xC7</i>
0xE160	<i>0x00</i>	<i>0x00</i>	<i>0x00</i>	<i>0xC0</i>	<i>0x00</i>	<i>0xC0</i>	<i>0x00</i>	<i>0xC0</i>
0xE168	0x04	0x20	0x08	0x20	0x04	0x18	0x02	0x18
0xE170	0x08	0x18	0x10	0x18	0x20	0x18	0x10	0x20
0xE178	0x00	0x20	0x20	0x20	0x40	0x20	0x80	0x20
0xE180	<i>0x00</i>	<i>0x00</i>	0x00	0x04	0x94	0x02	<i>0xF2</i>	<i>0x08</i>
0xE188	0x10	0x03	0x05	0xC0	0x40	0x00	0xFF	0x08
0xE190	0x05	0x00	0x00	0x00	0x00	0x00	0x00	0x00
0xE198	0x00	0x00	0x00	0x00	0x00	0x00	0x00	0x00
0xE1A0	0x00	0x00	0x00	0x00	0x00	0x00	0x00	0x00
0xE1A8	0x00	0x00	0x00	0x00	0x00	0x00	0x00	0x00
0xE1B0	0x00	0x00	0x00	0x00	0x00	0x00	0x00	0x00
0xE1B8	0x00	0x00	0x00	0x00	0x00	0x00	0x00	0x00
0xE1C0	0x00	0x00	0x00	0x00	0x00	0x00	0x00	0x00
0xE1C8	0x00	0x00	0x00	0x00	0x00	0x00	0x00	0x00
0xE1D0	0x00	0x00	0x00	0x00	0x00	0x00	0x00	0x00
0xE1D8	0x00	0x00	0x00	0x00	0x00	0x00	0x00	0x00
0xE1E0	0x00	0x00	0x00	0x00	0x00	0x00	0x00	0x00
0xE1E8	0x00	0x00	0x00	0x00	0x00	0x00	0x00	0x00
0xE1F0	0x00	0x00	0x00	0x00	0x00	0x00	0x00	0x00
0xE1F8	0x00	0x00	0x00	0x00	0x00	0x00	0x00	0x00

CONFIGURATION PARAMETERS DETAIL

The following sections detail the format and meaning of the configuration parameters from the *Configuration Parameters Memory Map*, [Table 2](#).

SequenceEventParameters

The SequenceEventParameters field in the configuration parameters specifies the rail identification, monitoring status, and sequencing options for each rail. The address map for these registers is as follows:

ADDRESS	SIZE	DEFAULT VALUE	DESCRIPTION
0xE080	1	0x50	Rail 1 identification, monitoring status and sequencing options
0xE081	1	0x51	Rail 2 identification, monitoring status, and sequencing options
0xE082	1	0x52	Rail 3 identification, monitoring status, and sequencing options
0xE083	1	0x53	Rail 4 identification, monitoring status, and sequencing options
0xE084	1	0x54	Rail 5 identification, monitoring status, and sequencing options
0xE085	1	0x55	Rail 6 identification, monitoring status, and sequencing options
0xE086	1	0x56	Rail 7 identification, monitoring status, and sequencing options
0xE087	1	0x57	Rail 8 identification, monitoring status, and sequencing options
0xE088	1	0x00	GPO1 identification, sequencing options
0xE089	1	0x49	GPO2 identification, sequencing options
0xE08A	1	0x4A	GPO3 identification, sequencing options
0xE08B	1	0x4B	GPO4 identification, sequencing options

The format of each register is as follows:

7	6	5	4	3	2	1	0
ENABLE		0	MON	RAIL/GPO			

RAIL

Rail #(n) – 1, RAIL = 0 through 7

GPO

GPO #(n) + 7, GPO = 8, 9, 0xA, 0xB

MON

Meaning

- 0 Do not monitor rail status (for event sequencing of GPOs)
- 1 Monitor rail status

ENABLE

Meaning

- 00 Sequence is disabled
- 01 Sequence is triggered after delay after sequence event
- 10 Sequence is triggered after parent rail achieves voltage level
- 11 Sequence is triggered after delay after parent rail achieves voltage regulation

SequenceEventLink

The SequenceEventLink field allows a parent rail (monitored input) to be specified for each ENx and GPOx output. The RESEQ bit (sequence after shutdown) allows an enable or GPO to be marked to sequence the system (as defined by the current sequencer configuration) after it has been shut down. The address map for these registers is as follows:

ADDRESS	SIZE	DEFAULT VALUE	DESCRIPTION
0xE08C	1	0x01	Rail 1 parent rail identifier and resequence indicator
0xE08D	1	0x00	Rail 2 parent rail identifier and resequence indicator
0xE08E	1	0x01	Rail 3 parent rail identifier and resequence indicator
0xE08F	1	0x04	Rail 4 parent rail identifier and resequence indicator
0xE090	1	0x01	Rail 5 parent rail identifier and resequence indicator
0xE091	1	0x04	Rail 6 parent rail identifier and resequence indicator
0xE092	1	0x05	Rail 7 parent rail identifier and resequence indicator
0xE093	1	0x06	Rail 8 parent rail identifier and resequence indicator
0xE094	1	0x00	GPO1 parent rail identifier and resequence indicator
0xE095	1	0x00	GPO2 parent rail identifier and resequence indicator
0xE096	1	0x00	GPO3 parent rail identifier and resequence indicator
0xE097	1	0x00	GPO4 parent rail identifier and resequence indicator

The format of each register is as follows:

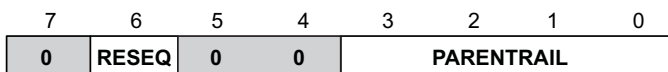

RESEQ	Meaning
0	Do not sequence after shutdown.
1	Sequence after shutdown.

PARENTRAIL	Meaning
0x0000	Sequence is dependent on RAIL1 achieving the specified event.
0x0001	Sequence is dependent on RAIL2 achieving the specified event.
0x0010	Sequence is dependent on RAIL3 achieving the specified event.
0x0011	Sequence is dependent on RAIL4 achieving the specified event.
0x0100	Sequence is dependent on RAIL5 achieving the specified event.
0x0101	Sequence is dependent on RAIL6 achieving the specified event.
0x0110	Sequence is dependent on RAIL7 achieving the specified event.
0x0111	Sequence is dependent on RAIL8 achieving the specified event.

UCD9080

SLVS692E – SEPTEMBER 2006 – REVISED MAY 2008

www.ti.com

SequenceEventData

The SequenceEventData field in the configuration parameters specifies the rail and GPO sequencing and shutdown parameters. The address map for these registers is as follows:

ADDRESS	SIZE	DEFAULT VALUE	DESCRIPTION
0xE098	2	0xE005	Rail 1 sequencing and shutdown parameters
0xE09A	2	0xA005	Rail 2 sequencing and shutdown parameters
0xE09C	2	0xE032	Rail 3 sequencing and shutdown parameters
0xE09E	2	0xE033	Rail 4 sequencing and shutdown parameters
0xE0A0	2	0xE033	Rail 5 sequencing and shutdown parameters
0xE0A2	2	0xE035	Rail 6 sequencing and shutdown parameters
0xE0A4	2	0xE035	Rail 7 sequencing and shutdown parameters
0xE0A6	2	0x0000	Rail 8 sequencing and shutdown parameters
0xE0A8	2	0x0000	GPO1 sequencing and shutdown parameters
0xE0AA	2	0x0000	GPO2 sequencing and shutdown parameters
0xE0AC	2	0x0000	GPO3 sequencing and shutdown parameters
0xE0AE	2	0x0000	GPO4 sequencing and shutdown parameters

The format for each register is as follows. The value in the ENABLE field of the SequenceEventParameters register determines the measure represented by the value in the RAILDATA field of the SequenceEventData register.



SEQPARAM	Meaning	ENABLE (SequenceEventParameters)	RAILDATA Meaning
000	Log only		
001	Sequence	01	Delay (in units of ms)
010	Reserved	10	Voltage (in units of Vref/1024 volts)
011	Reserved	11	Delay (in units of ms)
100	Reserved		
101	Retry 1 times		
110	Retry 0 times		
111	Reserved		

DependencyMasks

The DependencyMasks field in the configuration parameters defines the rail dependency masks used for rail and GPO shutdown. This mask represents the set of other rails and GPOs that should be shut down when this rail shuts down. Note that because only rails are monitored, the table only has entries for the shutdown of rails. In the dependency mask itself, there are bits that allow for GPO shutdown.

The address map for these registers is as follows:

ADDRESS	SIZE	DEFAULT VALUE	DESCRIPTION
0xE100	2	0x007F	Dependency mask for rail 1
0xE102	2	0x0001	Dependency mask for rail 2
0xE104	2	0x0002	Dependency mask for rail 3
0xE106	2	0x0004	Dependency mask for rail 4
0xE108	2	0x0008	Dependency mask for rail 5
0xE10A	2	0x0010	Dependency mask for rail 6
0xE10C	2	0x0020	Dependency mask for rail 7
0xE10E	2	0x0040	Dependency mask for rail 8

The format for each register is as follows:

15	14	13	12	11	10	9	8	7	6	5	4	3	2	1	0
0	0	0	0	GPO4	GPO3	GPO2	GPO1	RAIL8	RAIL7	RAIL6	RAIL5	RAIL4	RAIL3	RAIL2	RAIL1

RAILn or GPOn	Meaning
0	Shutdown of this rail does not shut down RAILn or GPOn.
1	Shutdown of this rail shuts down RAILn or GPOn.

UnderVoltageThresholds

The UnderVoltageThresholds field in the configuration parameters specifies each rail undervoltage threshold that is used when monitoring this rail. The address map for these registers is as follows:

ADDRESS	SIZE	DEFAULT VALUE	DESCRIPTION
0xE110	2	0x0000	Undervoltage threshold for rail 8
0xE112	2	0x0000	Undervoltage threshold for rail 7
0xE114	2	0x0000	Undervoltage threshold for rail 6
0xE116	2	0x0000	Undervoltage threshold for rail 5
0xE118	2	0x0000	Undervoltage threshold for rail 4
0xE11A	2	0x0000	Undervoltage threshold for rail 3
0xE11C	2	0x0000	Undervoltage threshold for rail 2
0xE11E	2	0x0000	Undervoltage threshold for rail 1

The format for each register is as follows:

15	14	13	12	11	10	9	8	7	6	5	4	3	2	1	0
0	0	0	0	0	V _{raw}										

The voltage conversion is dependent upon the configured voltage reference, and the pullup/pulldown resistors used on the board for each rail. The voltage reference is selected as either 2.5 V (internal) or V_{CC} (external). The formula to convert the desired rail UnderVoltageThreshold to V_{raw} follows:

Without external rail voltage divider:

$$V_{\text{raw}} = \frac{1024 \times V_{\text{RAILUV}}}{V_{\text{REF}}} \quad (3)$$

UCD9080

SLVS692E – SEPTEMBER 2006 – REVISED MAY 2008

www.ti.com

With external rail voltage divider:

$$V_{\text{raw}} = \frac{1024 \times V_{\text{RAILUV}}}{V_{\text{REF}}} \times \frac{R_{\text{PULLDOWN}}}{R_{\text{PULLDOWN}} + R_{\text{PULLUP}}} \quad (4)$$

OverVoltageThresholds

The OverVoltageThresholds field in the configuration parameters specifies each rail overvoltage threshold that is used when monitoring this rail. The address map for these registers is as follows:

ADDRESS	SIZE	DEFAULT VALUE	DESCRIPTION
0xE120	2	0x0400	Overvoltage threshold for rail 8
0xE122	2	0x0400	Overvoltage threshold for rail 7
0xE124	2	0x0400	Overvoltage threshold for rail 6
0xE126	2	0x0400	Overvoltage threshold for rail 5
0xE128	2	0x0400	Overvoltage threshold for rail 4
0xE12A	2	0x0400	Overvoltage threshold for rail 3
0xE12C	2	0x0400	Overvoltage threshold for rail 2
0xE12E	2	0x0400	Overvoltage threshold for rail 1

The format for each register is as follows:

15	14	13	12	11	10	9	8	7	6	5	4	3	2	1	0
0	0	0	0	0	Vraw										

The voltage conversion is dependent upon the configured voltage reference, and the pullup/pulldown resistors used on the board for each rail. The voltage reference is selected as either 2.5 V (internal) or V_{CC} (external). The formula to convert the desired rail OverVoltageThreshold to V_{raw} follows:

Without external rail voltage divider:

$$V_{\text{raw}} = \frac{1024 \times V_{\text{RAILOV}}}{V_{\text{REF}}} \quad (5)$$

With external voltage divider:

$$V_{\text{raw}} = \frac{1024 \times V_{\text{RAILOV}}}{V_{\text{REF}}} \times \frac{R_{\text{PULLDOWN}}}{R_{\text{PULLDOWN}} + R_{\text{PULLUP}}} \quad (6)$$

RampTime

The RampTime field in the configuration parameters specifies the maximum amount of time for each rail to achieve regulation. The address map for these registers is as follows:

ADDRESS	SIZE	DEFAULT VALUE	DESCRIPTION
0xE130	2	0x0FA0	Maximum voltage ramp time for rail 1
0xE132	2	0x0FA0	Maximum voltage ramp time for rail 2
0xE134	2	0x0FA0	Maximum voltage ramp time for rail 3
0xE136	2	0x0FA0	Maximum voltage ramp time for rail 4
0xE138	2	0x0FA0	Maximum voltage ramp time for rail 5
0xE13A	2	0x0FA0	Maximum voltage ramp time for rail 6
0xE13C	2	0x0FA0	Maximum voltage ramp time for rail 7
0xE13E	2	0x0FA0	Maximum voltage ramp time for rail 8

15	14	13	12	11	10	9	8	7	6	5	4	3	2	1	0
0	0	0	0	RAMPTIME											

RAMPTIME = RAILn RailTime (in units of ms).

OutOfRegulationWidth

The OutOfRegulationWidth field in the configuration parameters specifies the maximum amount of time that the rail is allowed to be out of regulation before an error is declared (glitch duration). The address map for these registers is as follows:

ADDRESS	SIZE	DEFAULT VALUE	DESCRIPTION
0xE140	2	0x0010	The out-of-regulation duration permissible without flagging error for rail 1
0xE142	2	0x0010	The out-of-regulation duration permissible without flagging error for rail 2
0xE144	2	0x0010	The out-of-regulation duration permissible without flagging error for rail 3
0xE146	2	0x0010	The out-of-regulation duration permissible without flagging error for rail 4
0xE148	2	0x0010	The out-of-regulation duration permissible without flagging error for rail 5
0xE14A	2	0x0010	The out-of-regulation duration permissible without flagging error for rail 6
0xE14C	2	0x0010	The out-of-regulation duration permissible without flagging error for rail 7
0xE14E	2	0x0010	The out-of-regulation duration permissible without flagging error for rail 8

The contents of this register are as follows:

15	14	13	12	11	10	9	8	7	6	5	4	3	2	1	0
0	0	0	0	OORW											

OORW = RAILn out-of-regulation glitch width (in units of 1/10 ms).

UnsequenceTime

The UnsequenceTime field in the configuration parameters specifies the amount of time that each rail should delay before unsequencing. The address map for these registers is as follows:

ADDRESS	SIZE	DEFAULT VALUE	DESCRIPTION
0xE150	2	0xC0FF	Unsequence delay for rail 1
0xE152	2	0xC1FF	Unsequence delay for rail 2
0xE154	2	0xC2FF	Unsequence delay for rail 3
0xE156	2	0xC3FF	Unsequence delay for rail 4
0xE158	2	0xC4FF	Unsequence delay for rail 5
0xE15A	2	0xC5FF	Unsequence delay for rail 6
0xE15C	2	0xC6FF	Unsequence delay for rail 7
0xE15E	2	0xC7FF	Unsequence delay for rail 8
0xE160	2	0x0000	Unsequence delay for GPO1
0xE162	2	0xC000	Unsequence delay for GPO2
0xE164	2	0xC000	Unsequence delay for GPO3
0xE166	2	0xC000	Unsequence delay for GPO4

The contents of this register are as follows:

15	14	13	12	11	10	9	8	7	6	5	4	3	2	1	0	
COPYSEQPARAM			0	USTIME												

COPYSEQPARAM = Copy SEQPARAM bit value (bits 15:13) in SequenceEvent Data register

USTIME = RAILn UnsequenceTime (in units of ms).

UCD9080

SLVS692E – SEPTEMBER 2006 – REVISED MAY 2008

www.ti.com

EnablePolarity

The EnablePolarity field in the configuration parameters specifies whether each power-supply enable or GPO is to be configured active-high or active-low. The address map for these registers is as follows:

ADDRESS	SIZE	DEFAULT VALUE	DESCRIPTION
0xE168	2	0x2004	Polarity for rail 1 enable
0xE16A	2	0x2008	Polarity for rail 2 enable
0xE16C	2	0x1804	Polarity for rail 3 enable
0xE16E	2	0x1802	Polarity for rail 4 enable
0xE170	2	0x1808	Polarity for rail 5 enable
0xE172	2	0x1810	Polarity for rail 6 enable
0xE174	2	0x1820	Polarity for rail 7 enable
0xE176	2	0x2010	Polarity for rail 8 enable
0xE178	2	0x2000	Polarity for GPO1
0xE17A	2	0x2020	Polarity for GPO2
0xE17C	2	0x2040	Polarity for GPO3
0xE17E	2	0x2080	Polarity for GPO4

The contents of this register are as follows:

15	14	13	12	11	10	9	8	7	6	5	4	3	2	1	0
POL		DEFAULT VALUES as specified previously													

POL	Meaning
0	Rail enable or GPO is active-low.
1	Rail enable or GPO is active-high.

ReferenceSelect

The ReferenceSelect field in the configuration parameters specifies which voltage reference is used on the UCD9080. The selected reference can be internal (2.5-V), or external via V_{CC} (3.3 V). The register address is 0xE186 and contents are as follows:

15	14	13	12	11	10	9	8	7	6	5	4	3	2	1	0
SELREF			0	0x8F2											

SELREF	Meaning
000	External reference selected (VCC)
001	Internal reference selected (2.5 V)

The default value for this register is 0x08F2, which selects the external reference.

LastUnusedSeq

The LastUnusedSeq field in the configuration parameters specifies the amount of time for the last rail to be shut down without creating an error. The register address is 0xE18E and contents are as follows:

15	14	13	12	11	10	9	8	7	6	5	4	3	2	1	0
LUTIME															

$$\text{LUTIME} = \text{Maximum value USTIME} + 255 \text{ (in units of ms)}$$

The default value for this register is 0x08FF.

APPLICATION INFORMATION

Typical Application Diagram

Figure 12 illustrates a typical power-supply sequencing configuration. Power Supply 1 and Power Supply X require active-low enables, whereas Power Supply 2 and Power Supply 3 require active-high enables. V_{OUT1} and V_{OUT3} exceed the selected A/D reference voltage, so these outputs are divided before being sampled by the MON1 and MON3 inputs. V_{OUT2} and V_{OUTX} are within the selected A/D reference voltage, so these outputs can be sampled directly by the MON2 and MON7 inputs. Figure 12 illustrates the use of the GPO digital output pins to provide status and power-on reset to other system devices.

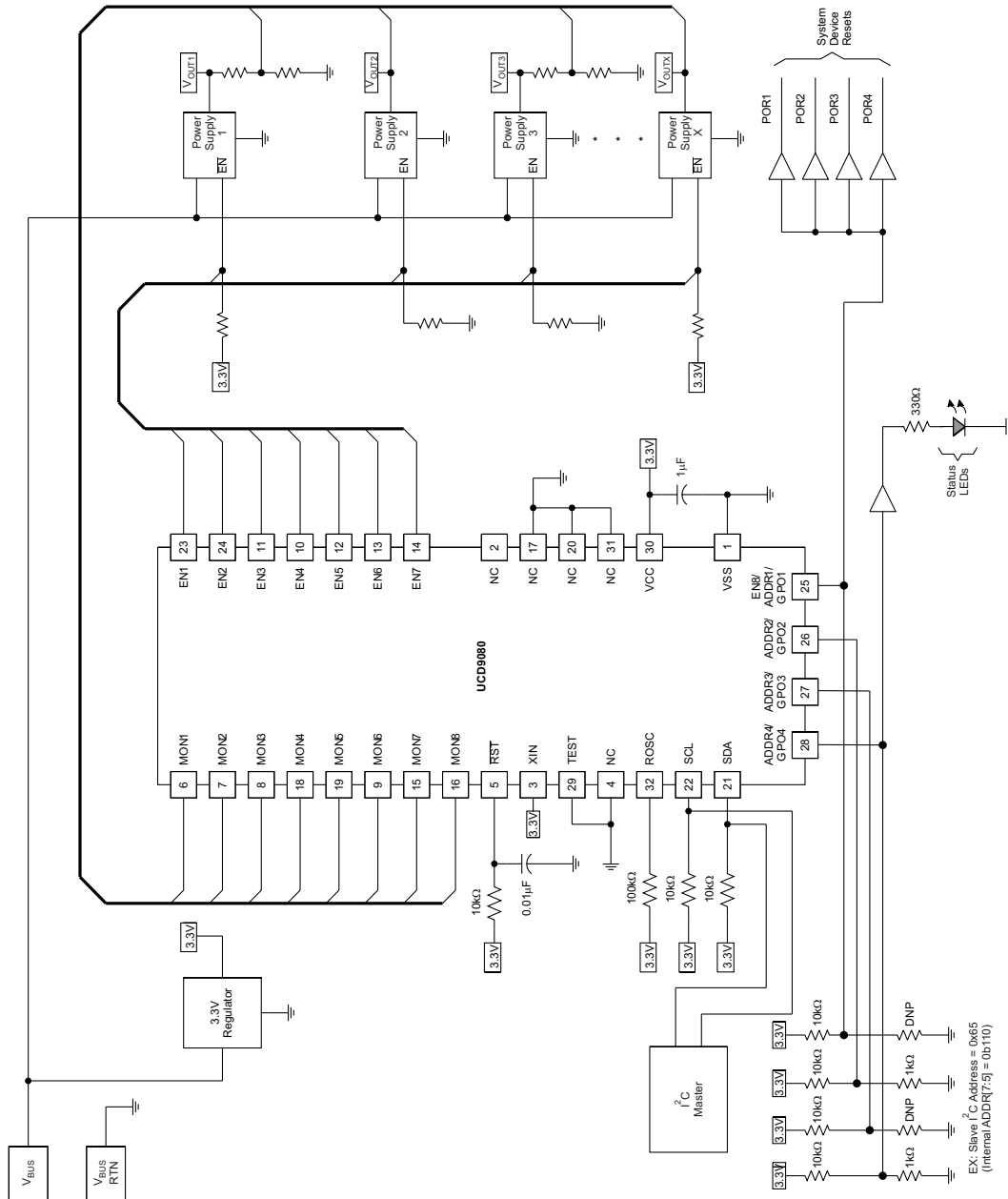

Figure 12. Typical Power-Supply Sequencing Application

Changes from Revision D (December 2007) to Revision E	Page
• Deleted ordering information table.....	2
• Changed NOM and MAX supply current specifications.....	2
• Updated Schmitt-trigger input signal list to add the ENx pins (inputs during reset).....	2
• Removed signal list from high-impedance leakage current specification.....	2
• Updated the digital output signal list to include the SCL pin (for clock stretching).....	3
• Updated the directionality for the ENx and SCL pins.....	7
• Clarified wording.....	9
• Clarified wording in several sentences and removed note at end of paragraph.....	9
• Moved this section to follow the Power-Supply Enables section. Minor wording change.....	9
• Added new section to describe ENx and GPOx behavior during device reset, and to describe I ² C address and GPOx polarity relationship.....	9
• Clarified wording in sequence paragraph.....	10
• Clarified wording in several paragraphs.....	11
• Clarified device time counter reset.....	16
• Clarified FLASHLOCK wording.....	18
• Clarified RESTART wording.....	18
• Clarified WDATA/WADDR wording.....	18
• Clarified wording in several steps.....	19
• Changed pin names from NIC to NC for pins 2, 4, 17, 20, 31.....	29

Changes from Revision C (January 2007) to Revision D	Page
• Changed minimum analog supply and positive built-in reference active V _{CC(min)} voltage. Removed minimum sampling voltage, 1.5-V internal reference, and DCO OPERATING PERIOD specifications.....	3
• Added specification for data hold time, t _{HD,DAT} and notes 3 and 4.....	6
• Changed pin #2 from "connect to VSS" to "do not connect".....	7
• Removed critica-rail-specification sentence from paragraph 4.....	10
• Added Ignore option and updated available retry options. Updated descriptions of options.....	10
• Added version register and changed WDATA access type from w to rw	13
• Removed reference to flash and non-volatile error log feature in NVERRLOG bit description.....	17
• Change WDATA access type from w to rw	19
• Removed <i>Resetting the Flash Error Logs</i> section.....	19
• Added the <i>UserData</i> section.....	20
• Updated factory byte values.....	20
• Updated factory byte values.....	21
• Removed retry 2, retry 3, retry 4, and retry continuously options.....	24
• Removed SaveRailLog register description.....	28
• Removed pin-2 connection to ground.....	29

PACKAGING INFORMATION

Orderable Device	Status (1)	Package Type	Package Drawing	Pins	Package Qty	Eco Plan (2)	Lead/Ball Finish (6)	MSL Peak Temp (3)	Op Temp (°C)	Device Marking (4/5)	Samples
UCD9080RHBR	NRND	VQFN	RHB	32	3000	Green (RoHS & no Sb/Br)	CU NIPDAU	Level-2-260C-1 YEAR	-40 to 85	UCD 9080	
UCD9080RHBRG4	NRND	VQFN	RHB	32	3000	Green (RoHS & no Sb/Br)	CU NIPDAU	Level-2-260C-1 YEAR	-40 to 85	UCD 9080	
UCD9080RHBT	NRND	VQFN	RHB	32	250	Green (RoHS & no Sb/Br)	CU NIPDAU	Level-2-260C-1 YEAR	-40 to 85	UCD 9080	
UCD9080RHBTG4	NRND	VQFN	RHB	32	250	Green (RoHS & no Sb/Br)	CU NIPDAU	Level-2-260C-1 YEAR	-40 to 85	UCD 9080	

(1) The marketing status values are defined as follows:

ACTIVE: Product device recommended for new designs.

LIFEBUY: TI has announced that the device will be discontinued, and a lifetime-buy period is in effect.

NRND: Not recommended for new designs. Device is in production to support existing customers, but TI does not recommend using this part in a new design.

PREVIEW: Device has been announced but is not in production. Samples may or may not be available.

OBSOLETE: TI has discontinued the production of the device.

(2) Eco Plan - The planned eco-friendly classification: Pb-Free (RoHS), Pb-Free (RoHS Exempt), or Green (RoHS & no Sb/Br) - please check <http://www.ti.com/productcontent> for the latest availability information and additional product content details.

TBD: The Pb-Free/Green conversion plan has not been defined.

Pb-Free (RoHS): TI's terms "Lead-Free" or "Pb-Free" mean semiconductor products that are compatible with the current RoHS requirements for all 6 substances, including the requirement that lead not exceed 0.1% by weight in homogeneous materials. Where designed to be soldered at high temperatures, TI Pb-Free products are suitable for use in specified lead-free processes.

Pb-Free (RoHS Exempt): This component has a RoHS exemption for either 1) lead-based flip-chip solder bumps used between the die and package, or 2) lead-based die adhesive used between the die and leadframe. The component is otherwise considered Pb-Free (RoHS compatible) as defined above.

Green (RoHS & no Sb/Br): TI defines "Green" to mean Pb-Free (RoHS compatible), and free of Bromine (Br) and Antimony (Sb) based flame retardants (Br or Sb do not exceed 0.1% by weight in homogeneous material)

(3) MSL, Peak Temp. - The Moisture Sensitivity Level rating according to the JEDEC industry standard classifications, and peak solder temperature.

(4) There may be additional marking, which relates to the logo, the lot trace code information, or the environmental category on the device.

(5) Multiple Device Markings will be inside parentheses. Only one Device Marking contained in parentheses and separated by a "~" will appear on a device. If a line is indented then it is a continuation of the previous line and the two combined represent the entire Device Marking for that device.

(6) Lead/Ball Finish - Orderable Devices may have multiple material finish options. Finish options are separated by a vertical ruled line. Lead/Ball Finish values may wrap to two lines if the finish value exceeds the maximum column width.

Important Information and Disclaimer: The information provided on this page represents TI's knowledge and belief as of the date that it is provided. TI bases its knowledge and belief on information provided by third parties, and makes no representation or warranty as to the accuracy of such information. Efforts are underway to better integrate information from third parties. TI has taken and continues to take reasonable steps to provide representative and accurate information but may not have conducted destructive testing or chemical analysis on incoming materials and chemicals. TI and TI suppliers consider certain information to be proprietary, and thus CAS numbers and other limited information may not be available for release.

In no event shall TI's liability arising out of such information exceed the total purchase price of the TI part(s) at issue in this document sold by TI to Customer on an annual basis.

TAPE AND REEL INFORMATION

QUADRANT ASSIGNMENTS FOR PIN 1 ORIENTATION IN TAPE

*All dimensions are nominal

Device	Package Type	Package Drawing	Pins	SPQ	Reel Diameter (mm)	Reel Width W1 (mm)	A0 (mm)	B0 (mm)	K0 (mm)	P1 (mm)	W (mm)	Pin1 Quadrant
UCD9080RHBR	VQFN	RHB	32	3000	330.0	12.4	5.3	5.3	1.5	8.0	12.0	Q2
UCD9080RHBT	VQFN	RHB	32	250	180.0	12.4	5.3	5.3	1.5	8.0	12.0	Q2

TAPE AND REEL BOX DIMENSIONS

*All dimensions are nominal

Device	Package Type	Package Drawing	Pins	SPQ	Length (mm)	Width (mm)	Height (mm)
UCD9080RHBR	VQFN	RHB	32	3000	367.0	367.0	35.0
UCD9080RHBT	VQFN	RHB	32	250	210.0	185.0	35.0

GENERIC PACKAGE VIEW

RHB 32

VQFN - 1 mm max height

5 x 5, 0.5 mm pitch

PLASTIC QUAD FLATPACK - NO LEAD

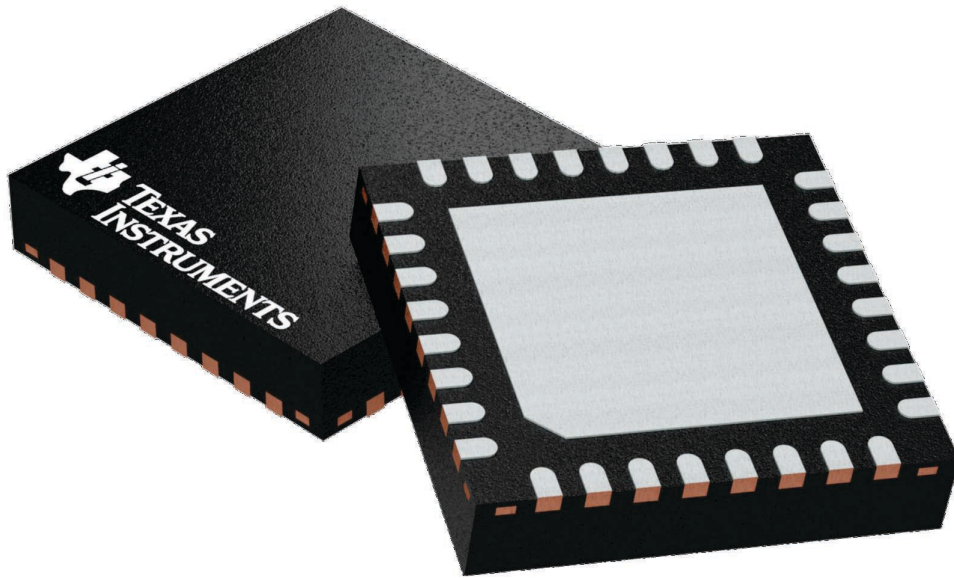

Images above are just a representation of the package family, actual package may vary.
Refer to the product data sheet for package details.

4224745/A

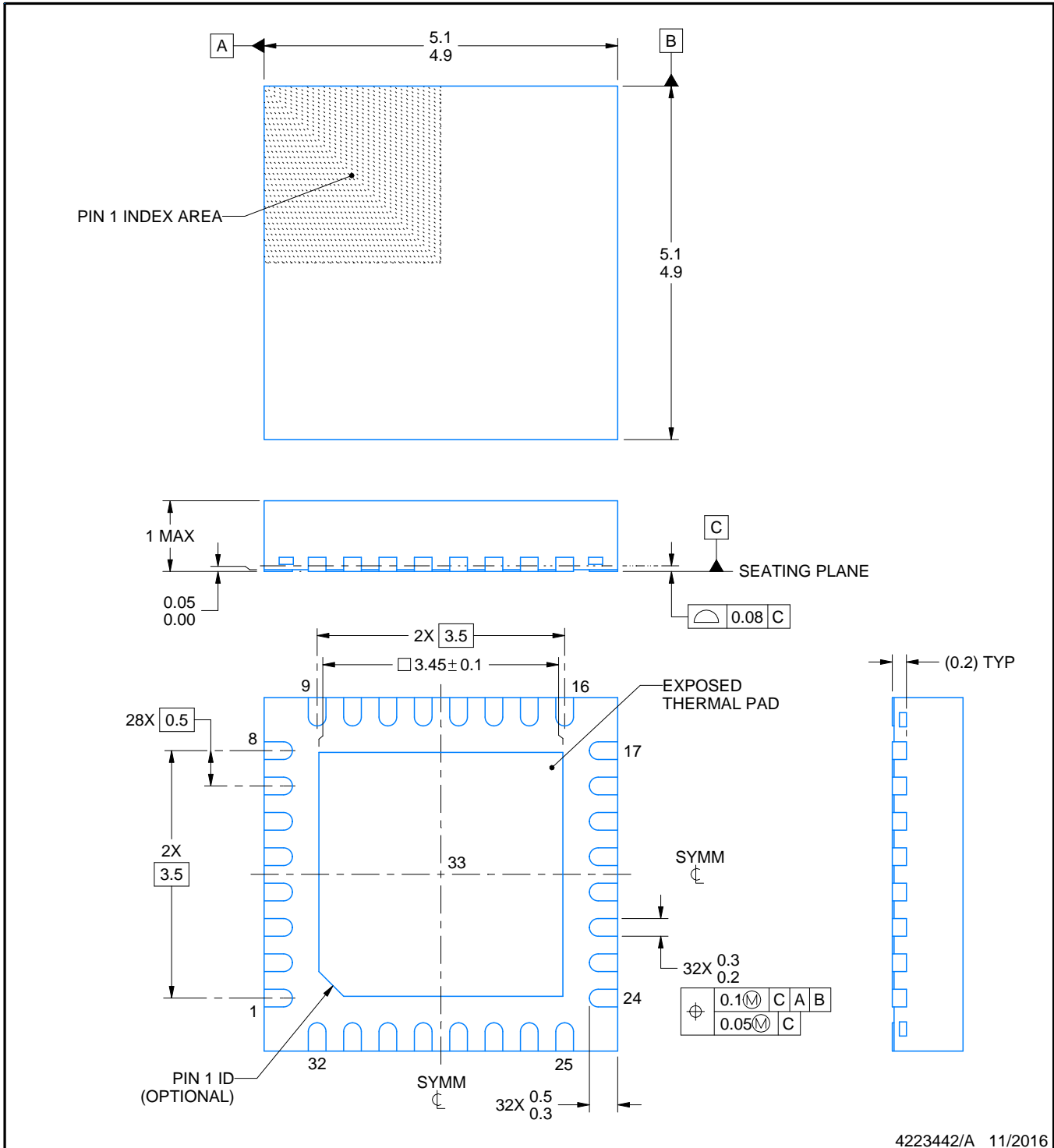
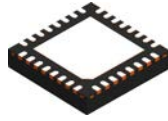

NOTES:

1. All linear dimensions are in millimeters. Any dimensions in parenthesis are for reference only. Dimensioning and tolerancing per ASME Y14.5M.
2. This drawing is subject to change without notice.
3. The package thermal pad must be soldered to the printed circuit board for thermal and mechanical performance.

EXAMPLE BOARD LAYOUT

RHB0032E

VQFN - 1 mm max height

PLASTIC QUAD FLATPACK - NO LEAD

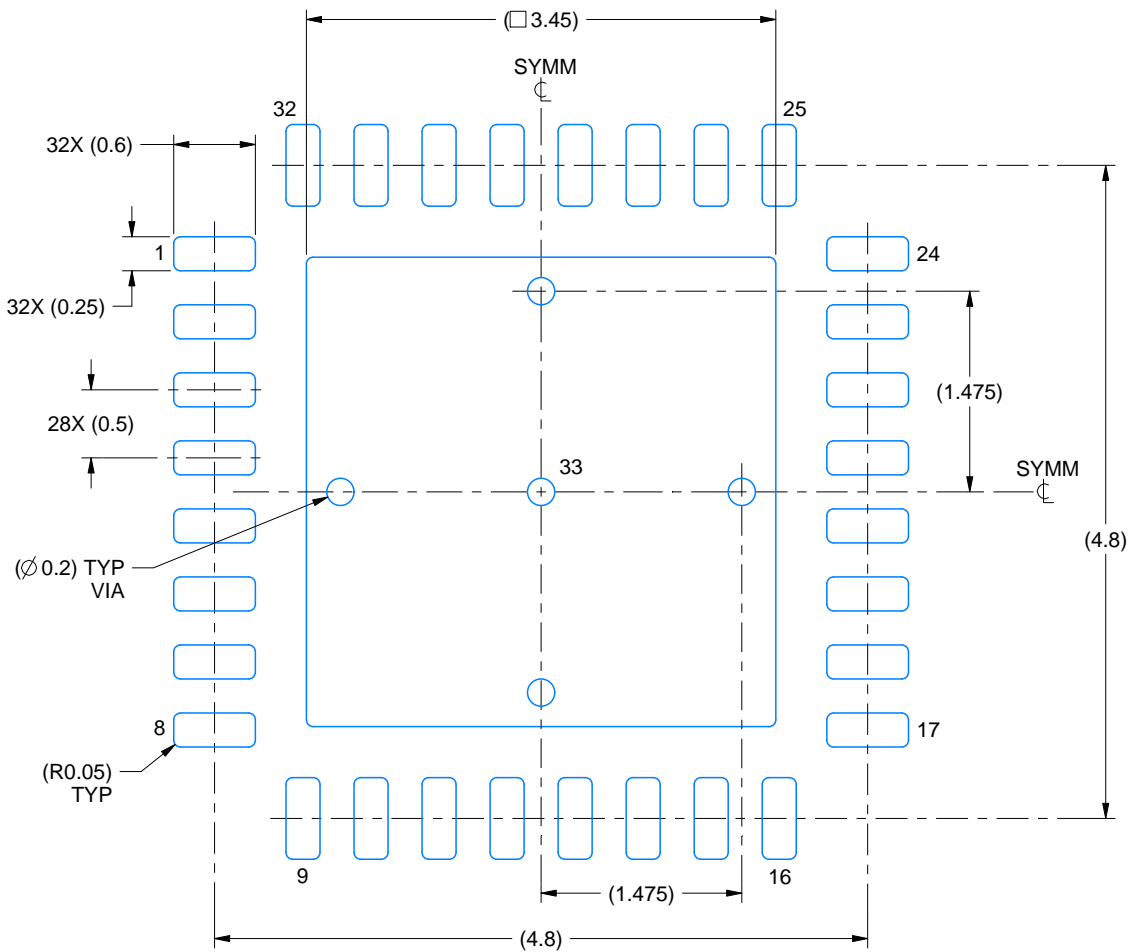

LAND PATTERN EXAMPLE
SCALE:18X

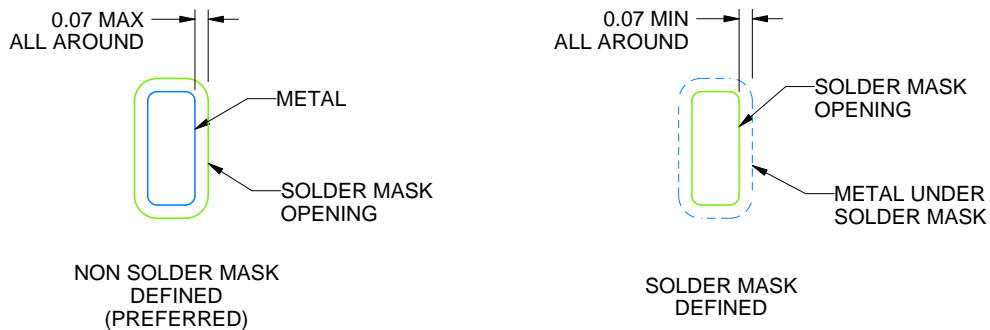

SOLDER MASK DETAILS

4223442/A 11/2016

NOTES: (continued)

4. This package is designed to be soldered to a thermal pad on the board. For more information, see Texas Instruments literature number SLUA271 (www.ti.com/lit/sluea271).
5. Vias are optional depending on application, refer to device data sheet. If any vias are implemented, refer to their locations shown on this view. It is recommended that vias under paste be filled, plugged or tented.

EXAMPLE STENCIL DESIGN

RHB0032E

VQFN - 1 mm max height

PLASTIC QUAD FLATPACK - NO LEAD

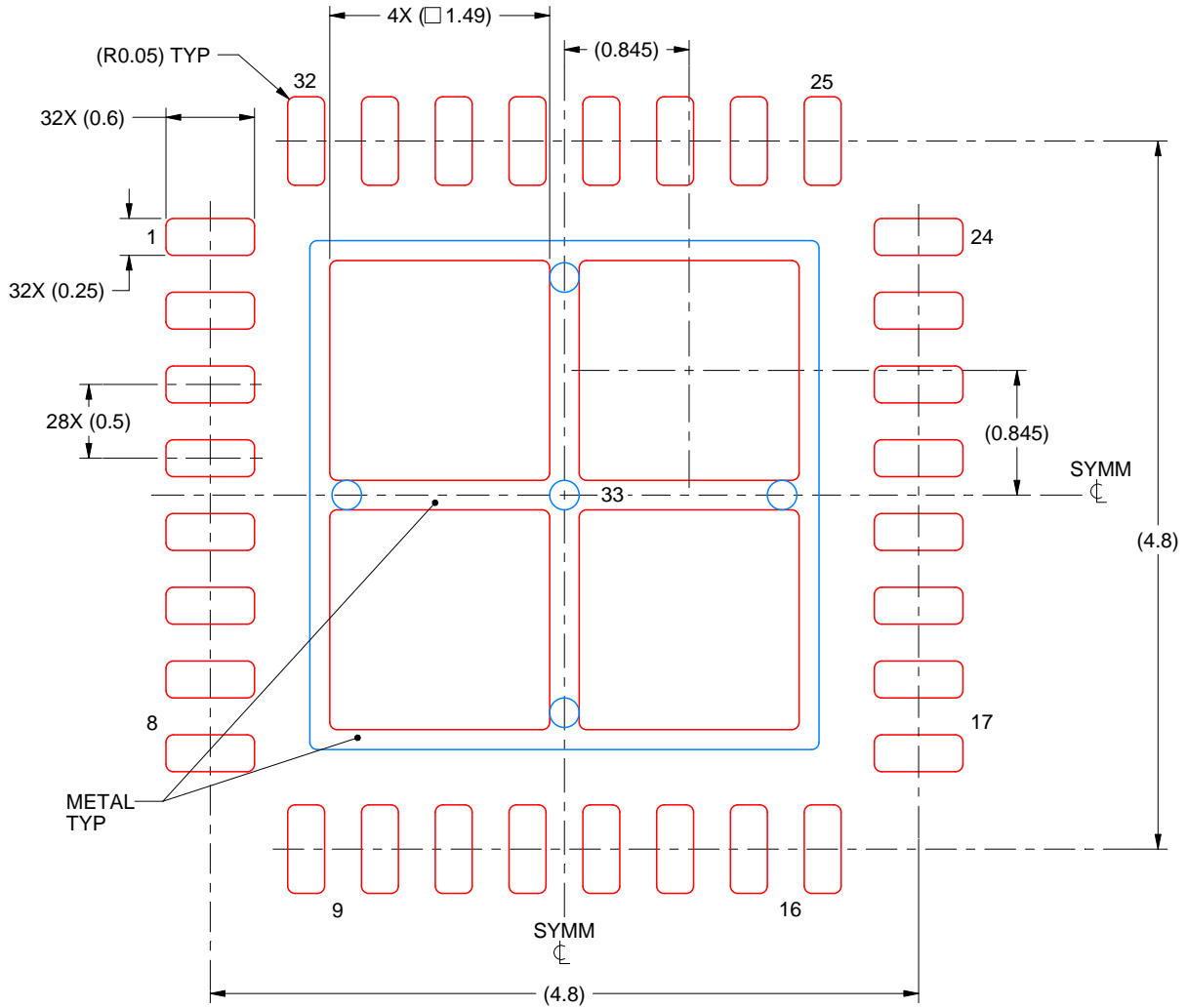

SOLDER PASTE EXAMPLE
 BASED ON 0.125 mm THICK STENCIL

EXPOSED PAD 33:
 75% PRINTED SOLDER COVERAGE BY AREA UNDER PACKAGE
 SCALE:20X

4223442/A 11/2016

NOTES: (continued)

6. Laser cutting apertures with trapezoidal walls and rounded corners may offer better paste release. IPC-7525 may have alternate design recommendations.

IMPORTANT NOTICE AND DISCLAIMER

TI PROVIDES TECHNICAL AND RELIABILITY DATA (INCLUDING DATASHEETS), DESIGN RESOURCES (INCLUDING REFERENCE DESIGNS), APPLICATION OR OTHER DESIGN ADVICE, WEB TOOLS, SAFETY INFORMATION, AND OTHER RESOURCES "AS IS" AND WITH ALL FAULTS, AND DISCLAIMS ALL WARRANTIES, EXPRESS AND IMPLIED, INCLUDING WITHOUT LIMITATION ANY IMPLIED WARRANTIES OF MERCHANTABILITY, FITNESS FOR A PARTICULAR PURPOSE OR NON-INFRINGEMENT OF THIRD PARTY INTELLECTUAL PROPERTY RIGHTS.

These resources are intended for skilled developers designing with TI products. You are solely responsible for (1) selecting the appropriate TI products for your application, (2) designing, validating and testing your application, and (3) ensuring your application meets applicable standards, and any other safety, security, or other requirements. These resources are subject to change without notice. TI grants you permission to use these resources only for development of an application that uses the TI products described in the resource. Other reproduction and display of these resources is prohibited. No license is granted to any other TI intellectual property right or to any third party intellectual property right. TI disclaims responsibility for, and you will fully indemnify TI and its representatives against, any claims, damages, costs, losses, and liabilities arising out of your use of these resources.

TI's products are provided subject to TI's Terms of Sale (www.ti.com/legal/termsofsale.html) or other applicable terms available either on ti.com or provided in conjunction with such TI products. TI's provision of these resources does not expand or otherwise alter TI's applicable warranties or warranty disclaimers for TI products.

Mailing Address: Texas Instruments, Post Office Box 655303, Dallas, Texas 75265
Copyright © 2019, Texas Instruments Incorporated

Looking for pricing, stock, or lifecycle information?

Click below to explore more details on WIN SOURCE:

 [View UCD9080RHBTG4](#) on WIN SOURCE

 [Texas Instruments](#) Information

Optimize Your Supply Chain with WIN SOURCE Solutions

-  Global Sourcing Solution
-  Obsolete Management
-  Cost Control Management
-  Shortage Management
-  Alternative Solution
-  Excess Inventory Management