



**THE DATASHEET OF  
UCD9081RHBTG4**



# UCD9081 8-Channel Power Supply Sequencer and Monitor With Error Logging

## 1 Features

- Single Supply Voltage: 3.3 V
- Low Power Consumption: 3-mA Nominal Supply Current
- Sequences and Monitors Eight Voltage Rails
- Rail Voltages Sampled With 3.2-mV Resolution
- Internal or External Voltage Reference
- Four Configurable Digital Outputs for Power-On-Reset and Other Functions
- Configurable Digital Output Polarity
- Flexible Rail Sequencing Based on Timeline (ms), Parent Rail Regulation Window, or Parent Rail Achieving Defined Threshold
- Independent Under- and Overvoltage Thresholds Per Rail
- Configurable Regulation Expiration Times Per Rail
- Flexible Alarm Processing: Ignore, Log Only, Retry n Times, Retry Continuously, Sequence, Parent Rail Can Shutdown Child Rails
- Alarm Conditions Logged With Timestamp: Under- and Overvoltage Glitch, Sustained Under- and Overvoltage, Rail Did Not Start
- On-Chip Flash for Storing User Data
- Error Logging to Flash for System Failure Analysis
- I<sup>2</sup>C™ Interface for Configuration and Monitoring
- Microsoft Windows™ GUI for Configuration and Monitoring

## 2 Applications

- Telecommunications Switches
- Servers
- Networking Equipment
- Test Equipment
- Industrial
- Any System Requiring Sequencing of Multiple Voltage Rails

## 3 Description

The UCD9081 power-supply sequencer controls the enable sequence of up to eight independent voltage rails and provides four general-purpose digital outputs (GPO). The device operates from a 3.3-V supply, provides 3.2-mV resolution of voltage rails, and requires no external memory or clock. The UCD9081 monitors the voltage rails independently and has a high degree of rail sequence and alarm response options. The sequencing of rails can be based on timed events or on timed events in conjunction with other rails achieving regulation or a voltage threshold. In addition, each rail is monitored for undervoltage and overvoltage glitches and thresholds. Each rail the UCD9081 monitors can be configured to shut down a user-defined set of other rails and GPOs, and alarm conditions are monitored on a per-rail basis.

Figure 20 shows the UCD9081 power-supply sequencer in a typical application.

### Device Information<sup>(1)</sup>

PART NUMBER	PACKAGE	BODY SIZE (NOM)
UCD9081	VQFN (32)	5.00 mm x 5.00 mm

(1) For all available packages, see the orderable addendum at the end of the data sheet.

### Functional Block Diagram

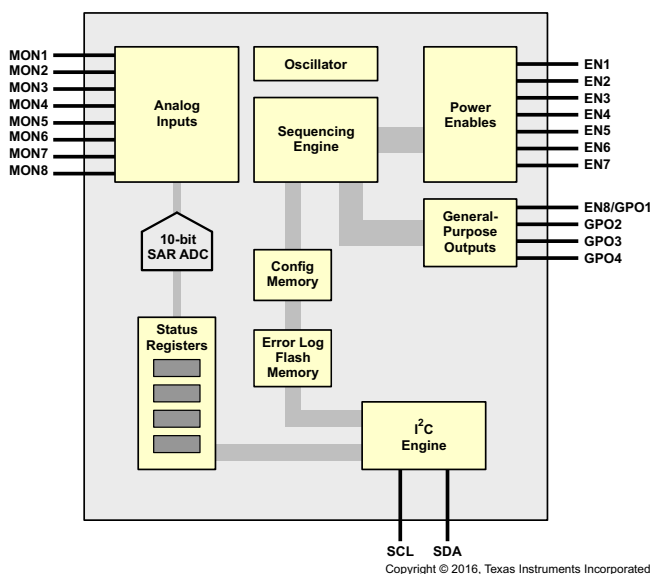

### Typical Application Diagram

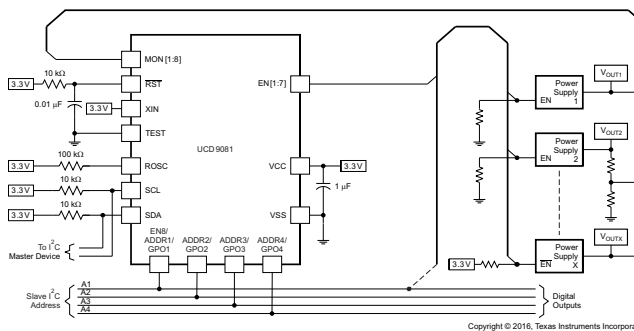

## Table of Contents

<b>1 Features</b> ..... 1 <b>2 Applications</b> ..... 1 <b>3 Description</b> ..... 1 <b>4 Revision History</b> ..... 2 <b>5 Pin Configuration and Functions</b> ..... 3 <b>6 Specifications</b> ..... 5 6.1 Absolute Maximum Ratings ..... 5 6.2 Recommended Operating Conditions ..... 5 6.3 Thermal Information ..... 5 6.4 Electrical Characteristics ..... 5 6.5 Timing Requirements: I <sup>2</sup> C Interface ..... 6 6.6 Typical Characteristics ..... 7 <b>7 Parameter Measurement Information</b> ..... 8 <b>8 Detailed Description</b> ..... 9 8.1 Overview ..... 9 8.2 Functional Block Diagram ..... 9 8.3 Feature Description ..... 10 8.4 Device Functional Modes ..... 11	8.5 Programming ..... 14 8.6 Register Maps ..... 18 <b>9 Application and Implementation</b> ..... 24 9.1 Application Information ..... 24 9.2 Typical Application ..... 25 <b>10 Power Supply Recommendations</b> ..... 28 <b>11 Layout</b> ..... 28 11.1 Layout Guidelines ..... 28 11.2 Layout Example ..... 28 <b>12 Device and Documentation Support</b> ..... 29 12.1 Documentation Support ..... 29 12.2 Receiving Notification of Documentation Updates ..... 29 12.3 Community Resources ..... 29 12.4 Trademarks ..... 29 12.5 Electrostatic Discharge Caution ..... 29 12.6 Glossary ..... 29 <b>13 Mechanical, Packaging, and Orderable Information</b> ..... 29
--	---

## 4 Revision History

NOTE: Page numbers for previous revisions may differ from page numbers in the current version.

Changes from Revision B (December 2010) to Revision C	Page
• Added <i>ESD Ratings</i> table, <i>Feature Description</i> section, <i>Device Functional Modes</i> , <i>Application and Implementation</i> section, <i>Power Supply Recommendations</i> section, <i>Layout</i> section, <i>Device and Documentation Support</i> section, and <i>Mechanical, Packaging, and Orderable Information</i> section .....	1
• Deleted <i>Ordering Information</i> table; see POA at the end of the data sheet .....	1
• Added <i>Thermal Information</i> table .....	5
• Moved <i>Timing Parameters for I<sup>2</sup>C Interface</i> table and <i>I<sup>2</sup>C Timing</i> diagram to <i>Specifications</i> .....	6
• Moved content in <i>Monitoring the UCD9081</i> to <i>Register Maps</i> .....	18

Changes from Revision A (September 2008) to Revision B	Page
• Added Note 1 to the PIN FUNCTIONS table .....	3
• Added Note regarding state of enable and digital I/O pins when the device contains factory configuration .....	15
• Added a reference to the <i>UCD9081 Programming Guide</i> .....	16

Changes from Original (June 2008) to Revision A	Page
• Changed the data sheet from Product Preview to Production; multiple changes throughout .....	1
• Changed first RAIL voltage equation From: $x V_{REF} To: x V_{R+}$ .....	19
• Changed second RAIL voltage equation From: $x V_{REF} To: x V_{R+}$ .....	19

## 5 Pin Configuration and Functions

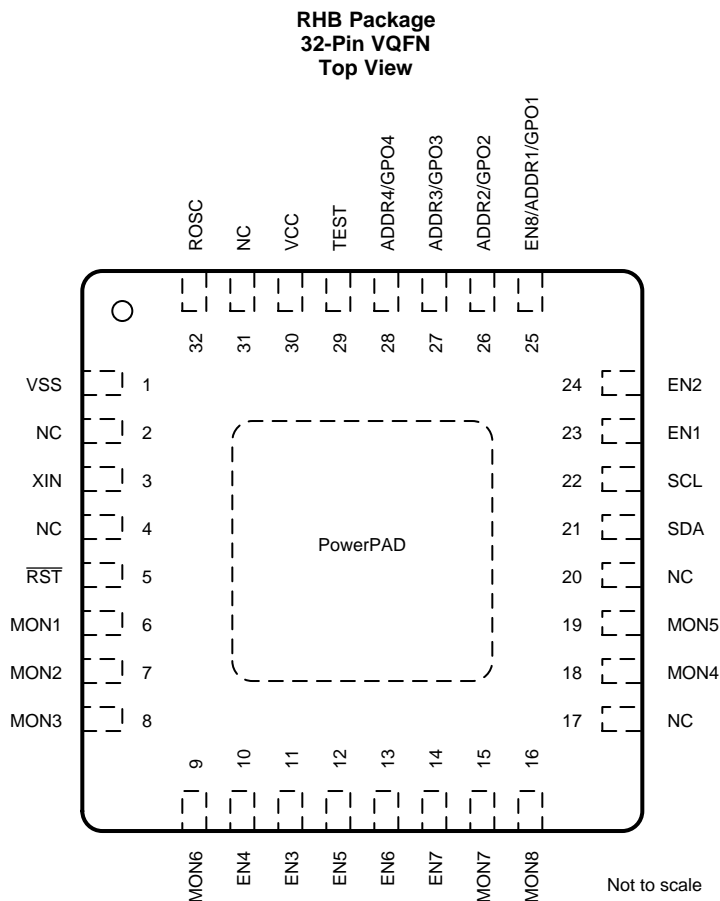

### Pin Functions

PIN <sup>(1)</sup>		I/O	DESCRIPTION
NAME	NO.		
ADDR2/GPO2	26	I/O	I <sup>2</sup> C address select 2, general-purpose digital output 2
ADDR3/GPO3	27	I/O	I <sup>2</sup> C address select 3, general-purpose digital output 3
ADDR4/GPO4	28	I/O	I <sup>2</sup> C address select 4, general-purpose digital output 4
EN1	23	I/O	Voltage rail 1 enable (digital output)
EN2	24	I/O	Voltage rail 2 enable (digital output)
EN3	11	I/O	Voltage rail 3 enable (digital output)
EN4	10	I/O	Voltage rail 4 enable (digital output)
EN5	12	I/O	Voltage rail 5 enable (digital output)
EN6	13	I/O	Voltage rail 6 enable (digital output)
EN7	14	I/O	Voltage rail 7 enable (digital output)
EN8/ADDR1/ GPO1	25	I/O	Voltage rail 8 enable (digital output), I <sup>2</sup> C address select 1, general-purpose digital output 1
MON1	6	I	Analog input for voltage rail 1
MON2	7	I	Analog input for voltage rail 2
MON3	8	I	Analog input for voltage rail 3
MON4	18	I	Analog input for voltage rail 4

(1) Enable and GPIO pins are in high-impedance state when a device is received from factory and during the first configuration programming done by customer.

**Pin Functions (continued)**

PIN <sup>(1)</sup>		I/O	DESCRIPTION
NAME	NO.		
MON5	19	I	Analog input for voltage rail 5
MON6	9	I	Analog input for voltage rail 6
MON7	15	I	Analog input for voltage rail 7
MON8	16	I	Analog input for voltage rail 8
NC	2	—	Do not connect
NC	4, 17, 20, 31	—	Recommended to connect to V <sub>SS</sub> , pin is not connected internally
ROSC	32	—	Internal oscillator frequency adjust. Must use 100-kΩ pullup to V <sub>CC</sub> for minimum drift and maximum frequency when sampling voltage rails.
$\overline{\text{RST}}$	5	I	Reset input
SCL	22	I/O	I <sup>2</sup> C clock. Must pull up to 3.3 V.
SDA	21	I/O	I <sup>2</sup> C data. Must pull up to 3.3 V.
TEST	29	I	Connect to V <sub>SS</sub>
V <sub>CC</sub>	30	—	Supply voltage
V <sub>SS</sub>	1	—	Ground reference
XIN	3	—	Connect to V <sub>CC</sub>
PowerPAD™	—	—	Package pad. Recommended to connect to V <sub>SS</sub> .

## 6 Specifications

### 6.1 Absolute Maximum Ratings

over operating free-air temperature range (unless otherwise noted)<sup>(1)</sup>

	MIN	MAX	UNIT
Voltage applied from $V_{CC}$ to $V_{SS}$	-0.3	4.1	V
Voltage applied to any pin <sup>(2)</sup>	-0.3	$V_{CC} + 0.3$	V
ESD diode current at any device terminal		$\pm 2$	mA
Storage temperature, $T_{stg}$	-40	85	°C

- (1) Stresses beyond those listed under *Absolute Maximum Ratings* may cause permanent damage to the device. These are stress ratings only, which do not imply functional operation of the device at these or any other conditions beyond those indicated under *Recommended Operating Conditions*. Exposure to absolute-maximum-rated conditions for extended periods may affect device reliability.
- (2) All voltages referenced to  $V_{SS}$ .

### 6.2 Recommended Operating Conditions

	MIN	NOM	MAX	UNIT
$V_{CC}$ Supply voltage during operation and configuration changes	3	3.3	3.6	V
$T_A$ Operating free-air temperature	-40		85	°C

### 6.3 Thermal Information

THERMAL METRIC <sup>(1)</sup>		UCD9081		UNIT
		RHB (VQFN)		
		32 PINS		
$R_{\theta JA}$	Junction-to-ambient thermal resistance	32.1		°C/W
$R_{\theta JC(top)}$	Junction-to-case (top) thermal resistance	18.1		°C/W
$R_{\theta JB}$	Junction-to-board thermal resistance	6		°C/W
$\Psi_{JT}$	Junction-to-top characterization parameter	0.2		°C/W
$\Psi_{JB}$	Junction-to-board characterization parameter	5.9		°C/W
$R_{\theta JC(bot)}$	Junction-to-case (bottom) thermal resistance	1.2		°C/W

- (1) For more information about traditional and new thermal metrics, see the [Semiconductor and IC Package Thermal Metrics](#) application report.

### 6.4 Electrical Characteristics

These specifications are over recommended ranges of supply voltage and operating free-air temperature (unless otherwise noted)

PARAMETER	TEST CONDITIONS	MIN	TYP	MAX	UNIT	
<b>SUPPLY CURRENT</b>						
$I_S$	Supply current into $V_{CC}$	$T_A = 25^\circ\text{C}$ , excluding external current		3	4	mA
$I_C$	Supply current during configuration	$V_{CC} = 3.6\text{ V}$		3	7	mA
<b>STANDARD INPUTS (RST, TEST)</b>						
$V_{IL}$	Low-level input voltage	$V_{CC} = 3\text{ V}$		$V_{SS}$	$V_{SS} + 0.6$	V
$V_{IH}$	High-level input voltage	$V_{CC} = 3\text{ V}$		$0.8 \times V_{CC}$	$V_{CC}$	V
<b>SCHMITT TRIGGER INPUTS (SDA, SCL, EN[1...7], EN8/ADDR1, ADDR[2...4])</b>						
$V_{IT+}$	Positive-going input threshold voltage	$V_{CC} = 3\text{ V}$		1.5	1.9	V
$V_{IT-}$	Negative-going input threshold voltage	$V_{CC} = 3\text{ V}$		0.9	1.3	V
$V_{hys}$	Input voltage hysteresis	$V_{CC} = 3\text{ V}$ , $V_{IT+} - V_{IT-}$		0.5	1	V
$I_{lkg}$	High-impedance leakage current				$\pm 50$	nA
<b>ANALOG INPUTS (MONx, ROSC)</b>						
$V_{CC}$	Analog supply voltage	$V_{SS} = 0\text{ V}$		3	3.6	V
$V_{MON<1..8>}$	Analog input voltage	Internal voltage reference selected		0	2.5	V
		External voltage reference selected ( $V_{CC}$ used as reference)		0	$V_{CC}$	

## Electrical Characteristics (continued)

These specifications are over recommended ranges of supply voltage and operating free-air temperature (unless otherwise noted)

PARAMETER		TEST CONDITIONS	MIN	TYP	MAX	UNIT
$C_I^{(1)}$	Input capacitance	Only one terminal can be selected at a time (MON1 to MON8)			27	pF
$R_I^{(1)}$	Input MUX ON resistance	$0\text{ V} \leq V_{\text{MON}x} \leq V_{\text{CC}}, V_{\text{CC}} = 3\text{ V}$			2000	$\Omega$
$I_{\text{ikg}}$	High-impedance leakage current	MON1 to MON8			$\pm 50$	nA
$V_{\text{REF+}}$	Positive internal reference voltage	Internal voltage reference selected, $V_{\text{CC}} = 3\text{ V}$	2.35	2.5	2.65	V
$V_{\text{TUE}}$	ADC total unadjusted error	$V_{\text{CC}} = 3\text{ V}$	$V_{\text{R+}} = 2.5\text{ V}$ (internal reference)		$\pm 12.2$	mV
			$V_{\text{R+}} = V_{\text{CC}}$ (external reference)		$\pm 14.7$	
$T_{\text{REF+}}^{(1)}$	Temperature coefficient of internal voltage reference	$I_{\text{(VREF+)}}$ is a constant in the range of $0\text{ mA} \leq I_{\text{(VREF+)}} \leq 1\text{ mA}, V_{\text{CC}} = 3\text{ V}$			$\pm 100$	ppm/°C
<b>MISCELLANEOUS</b>						
$T_{\text{retention}}$	Retention of configuration parameters	$T_J = 25^\circ\text{C}$	100			Years
<b>POR, BROWNOUT, RESET<sup>(2)(3)</sup></b>						
$t_{\text{d(BOR)}}$	Brownout				2000	$\mu\text{s}$
$V_{\text{CC(start)}}$	Brownout	$dV_{\text{CC}}/dt \leq 3\text{ V/s}$	$0.7 \times V_{\text{(B\_IT-)}}$			V
$V_{\text{(B\_IT-)}}$	Brownout	$dV_{\text{CC}}/dt \leq 3\text{ V/s}$			1.71	V
$V_{\text{hys(B\_IT-)}}$	Brownout	$dV_{\text{CC}}/dt \leq 3\text{ V/s}$	70	130	180	mV
$t_{\text{(reset)}}$	Brownout	Pulse length required at RST pin to accept reset internally, $V_{\text{CC}} = 3\text{ V}$	2			$\mu\text{s}$
<b>DIGITAL OUTPUTS (EN8/GPO1, GPO[2...4], EN[1...7], SDA, SCL)</b>						
$V_{\text{OH}}$	High-level output voltage	$I_{\text{OHmax}} = -1.5\text{ mA}^{(4)}, V_{\text{CC}} = 3\text{ V}$	$V_{\text{CC}} - 0.25$		$V_{\text{CC}}$	V
		$I_{\text{OHmax}} = -6\text{ mA}^{(5)}, V_{\text{CC}} = 3\text{ V}$	$V_{\text{CC}} - 0.6$		$V_{\text{CC}}$	
$V_{\text{OL}}$	Low-level output voltage	$I_{\text{OLmax}} = 1.5\text{ mA}^{(4)}, V_{\text{CC}} = 3\text{ V}$	$V_{\text{SS}}$		$V_{\text{SS}} + 0.25$	V
		$I_{\text{OLmax}} = 6\text{ mA}^{(5)}, V_{\text{CC}} = 3\text{ V}$	$V_{\text{SS}}$		$V_{\text{SS}} + 0.6$	
$I_{\text{ikg}}$	High-impedance leakage current	$V_{\text{CC}} = 3\text{ V}$			$\pm 50$	nA

(1) Not production tested. Limits verified by design.

(2) The current consumption of the brown-out module is already included in the  $I_{\text{CC}}$  current consumption data.

(3) During power up, device initialization starts following a period of  $t_{\text{d(BOR)}}$  after  $V_{\text{CC}} = V_{\text{(B\_IT-)}} + V_{\text{hys(B\_IT-)}}$ .

(4) The maximum total current,  $I_{\text{OHmax}}$  and  $I_{\text{OLmax}}$ , for all outputs combined, must not exceed  $\pm 12\text{ mA}$  to hold the maximum voltage drop specified.

(5) The maximum total current,  $I_{\text{OHmax}}$  and  $I_{\text{OLmax}}$ , for all outputs combined, must not exceed  $\pm 48\text{ mA}$  to hold the maximum voltage drop specified.

## 6.5 Timing Requirements: I<sup>2</sup>C Interface

		MIN	MAX	UNIT
$t_{\text{of}}$	Output fall time from $V_{\text{OH}}$ to $V_{\text{OL}}^{(1)}$ with a bus capacitance from 10 pF to 400 pF		250 <sup>(2)</sup>	ns
$C_I$	Capacitance for each pin		10	pF
$f_{\text{SCL}}$	SCL clock frequency	10	100	kHz
$t_{\text{HD,STA}}$	Repeated hold time START condition (after this period, the first clock pulse is generated)	4		$\mu\text{s}$
$t_{\text{HD,DAT}}$	Data hold time	0 <sup>(3)</sup>	3.45 <sup>(4)</sup>	$\mu\text{s}$
$t_{\text{LOW}}$	LOW period of the SCL clock	4.7		$\mu\text{s}$
$t_{\text{HIGH}}$	HIGH period of the SCL clock	4		$\mu\text{s}$
$t_{\text{SU,STA}}$	Setup time for repeated start condition	4.7		$\mu\text{s}$
$t_{\text{SU,DAT}}$	Data setup time	250		ns

(1) See [Electrical Characteristics](#)

(2) The maximum  $t_f$  for the SDA and SCL bus lines (300 ns) is longer than the specified maximum  $t_{\text{of}}$  for the output stages (250 ns). This allows series protection resistors,  $R_s$ , to be connected between the SDA/SCL pins and the SDA/SCL bus lines without exceeding the maximum specified  $t_f$ .

(3) A device must internally provide a hold time of at least 300 ns for the SDA signal to bridge the undefined region of the falling edge of SCL.

(4) The maximum  $t_{\text{HD,DAT}}$  must only be met if the device does not stretch the LOW period ( $t_{\text{LOW}}$ ) of the SCL signal.

Timing Requirements: I<sup>2</sup>C Interface (continued)

		MIN	MAX	UNIT
$t_r$	Rise time of both SDA and SCL signals		1000	ns
$t_f$	Fall time of both SDA and SCL signals		300	ns
$t_{SU;STO}$	Setup time for STOP condition	4		$\mu$ s
$t_{BUF}$	Bus free time between a STOP and START condition	4.7		$\mu$ s
$C_{(b)}$	Capacitive load for each bus line		400	pF
$V_{nL}$	Noise margin at the LOW level for each connected device (including hysteresis)	$0.1 \times V_{DD}$		V
$V_{nH}$	Noise margin at the HIGH level for each connected device (including hysteresis)	$0.2 \times V_{DD}$		V

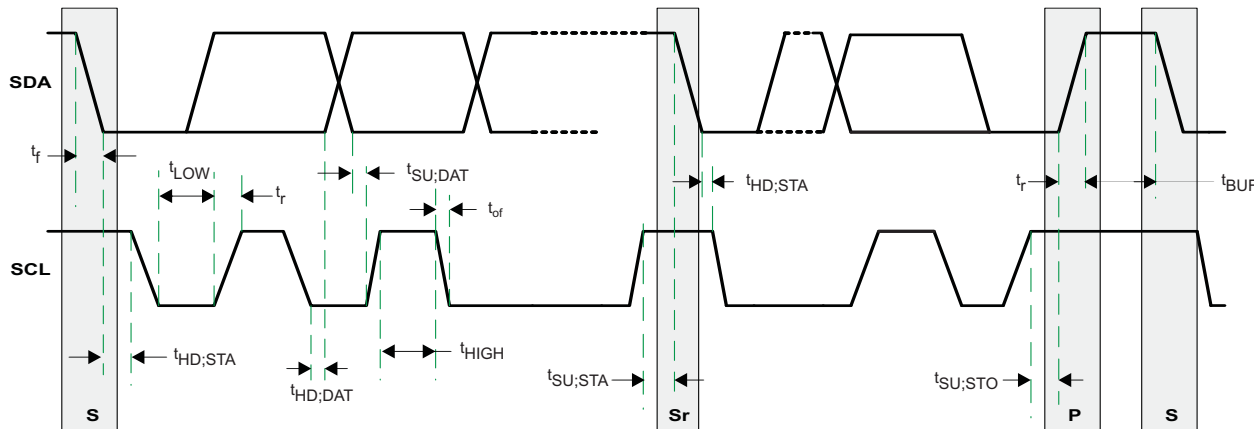
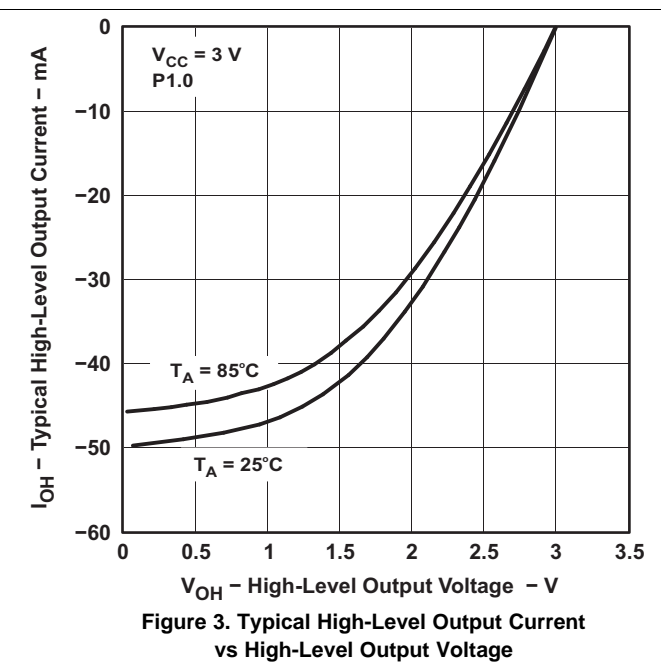
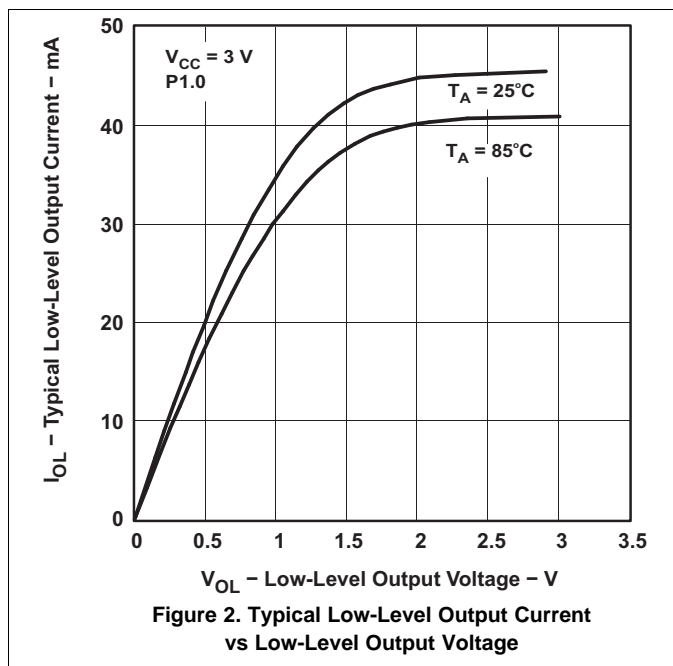

Figure 1. Timing Diagram for I<sup>2</sup>C Interface

6.6 Typical Characteristics

Digital outputs (only one output is loaded at a time)



## 7 Parameter Measurement Information

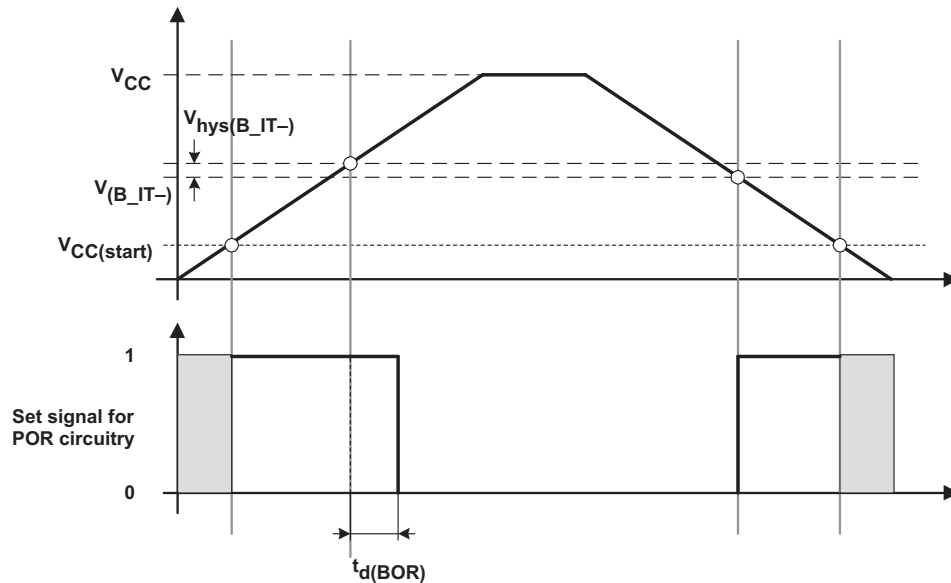

Figure 4. POR/Brownout Reset (BOR) vs Supply Voltage

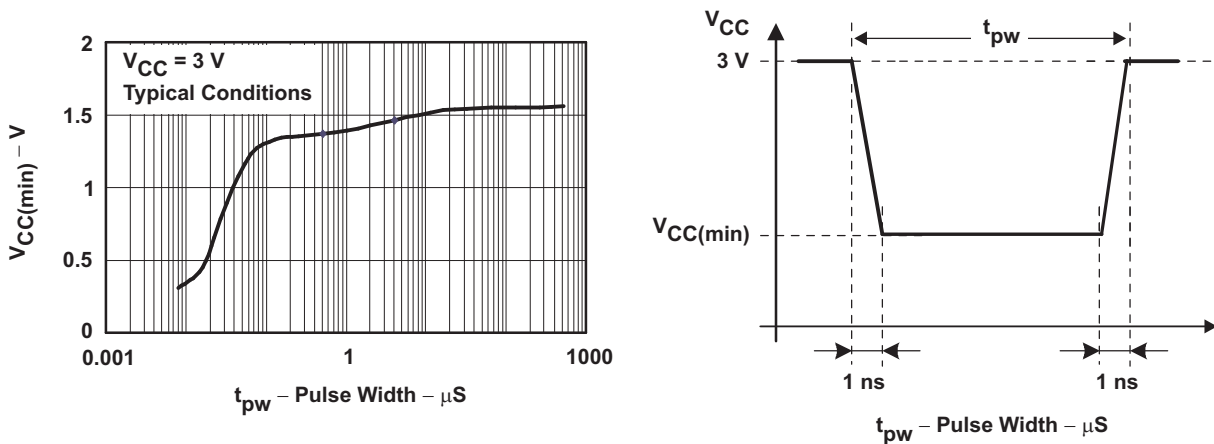

Figure 5.  $V_{CC(min)}$  Level With a Square Voltage Drop to Generate a POR/Brownout Signal

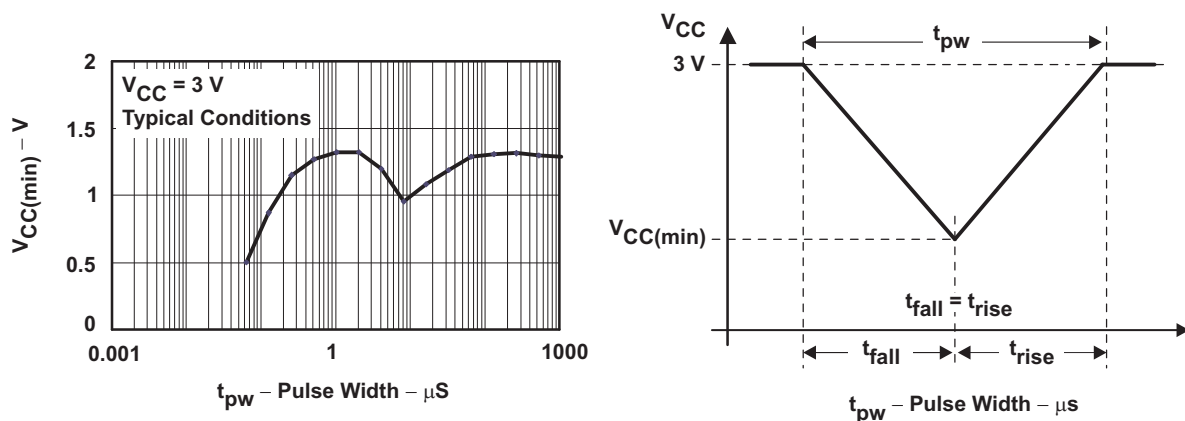

Figure 6.  $V_{CC(min)}$  Level With a Triangle Voltage Drop to Generate a POR/Brownout Signal

## 8 Detailed Description

### 8.1 Overview

Electronic systems that include CPU, DSP, microcontroller, FPGA, ASIC, and so forth, can have multiple voltage rails and require certain power on and off sequences to function correctly. The UCD9081 device can control up to 8 voltage rails and ensure correct power sequences during normal condition and fault conditions.

In addition to sequencing, UCD9081 can continuously monitor rail voltages, fault conditions, and report the system health information to a I<sup>2</sup>C host, improving the long-term reliability of the system.

Also, UCD9081 can protect electronic systems by responding to power system faults. The fault responses are conveniently configured by users through PC-based GUI. Fault events are stored in on-chip nonvolatile flash memory to assist failure analysis.

The UCD9081 can control up to four general-purpose digital outputs through the same sequencing mechanisms as the power supply enables, which can be used for digital signals for other devices.

### 8.2 Functional Block Diagram

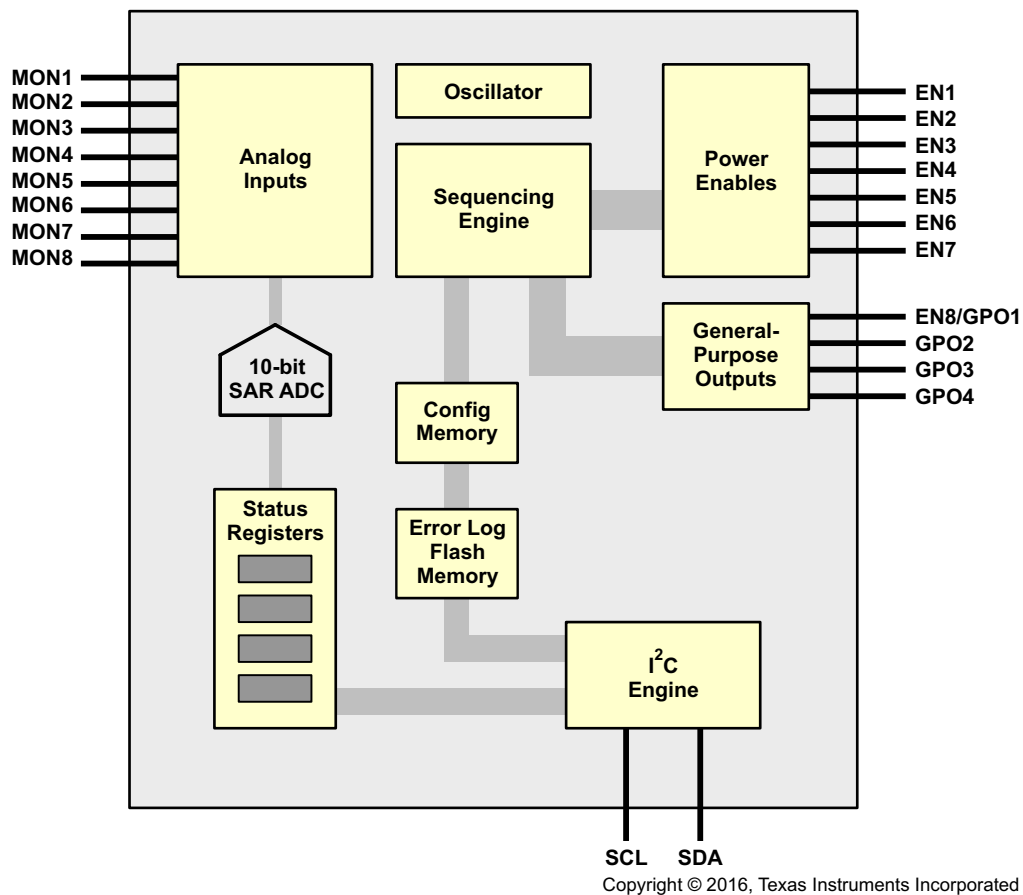

## 8.3 Feature Description

### 8.3.1 Rail Configuration

A rail includes voltage monitoring pin, a power-supply enable. UCD9081 can support up to 8 rails. Once the assigned rail is selected, other key monitoring and sequencing criteria are selected for each rail from rail configuration:

- Enable pin polarity
- Undervoltage (UV) and overvoltage (OV) fault limits
- Maximum time allowed before an alarm is declared
- Maximum time allowed achieving regulation (voltage between UV or OV range)
- Masks glitches from error log windows
- Log errors to flash
- Sequence after shutdown
- Voltage divider
- Sequence conditions selections
- Alarm actions

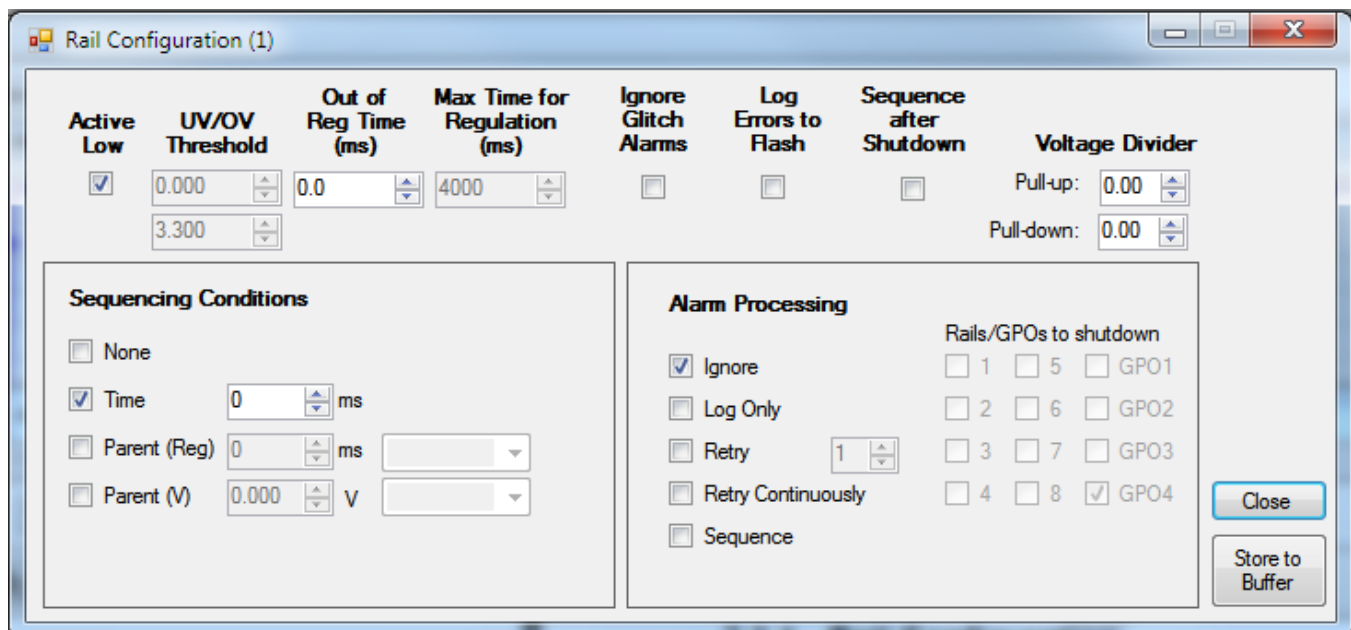

Figure 7. GUI Rail Configuration

### 8.3.2 Graphical User Interface (GUI)

UCD9081 designer is provided for device configuration. This PC-based graphical user interface (GUI) offers an intuitive I<sup>2</sup>C interface to the device. It allows the design engineer to configure the system operating parameters for the application without directly using I<sup>2</sup>C commands, store the configuration to on-chip nonvolatile memory, and observe system status (voltage, and so forth). The UCD9081 GUI can be downloaded from [www.ti.com](http://www.ti.com) in the product folder.

## 8.4 Device Functional Modes

### 8.4.1 Power Supply Sequencing

The UCD9081 can be configured to sequence power supply rails using the enable signals (ENx) or the general-purpose outputs (GPOx) in one of four ways:

1. A rail can be configured to not be sequenced
2. Using a delay time after UCD9081 RESET. The enable or GPO is asserted after UCD9081 RESET plus the user specified delay
3. Using a delay time after another (parent) rail has achieved regulation ( $V_{RAIL}$  is within specified under- and overvoltage settings). The enable or GPO is asserted after the (parent) rail is in regulation plus the user specified delay.
4. Using a (parent) rail voltage. The enable or GPO is asserted after the (parent) rail voltage is greater than or equal to the user specified voltage.

### 8.4.2 Power-Supply Enables

The UCD9081 can sequence and enable or disable up to eight power supplies through the ENx (EN1 to EN8) signals. These signals can be configured active-high or active-low, supporting power supplies with either polarity.

EN8 can also be configured as a GPO (GPO1). EN8/ADDR1/GPO1 is also used for I<sup>2</sup>C address selection (ADDR1).

While the UCD9081 is in RESET, the enable signals are in a high-impedance state. The enable signals must be pulled up or down on the board according to the desired default power-supply state (enabled or disabled).

### 8.4.3 General-Purpose Outputs

The UCD9081 can control up to four general-purpose digital outputs through the same sequencing mechanisms as the power supply enables. These general-purpose outputs (GPO1–GPO4) can be used for digital signals such as resets or status inputs to other devices. These signals are multiplexed with other functions (primarily I<sup>2</sup>C address selection). See [Pin Configuration and Functions](#) to ensure that these signals are used properly by the application. The GPO1 signal is also multiplexed with EN8.

### 8.4.4 Device Reset

UCD9081 RESET occurs due to one of the following conditions:

- External  $\overline{RST}$  pin is asserted
- Power is applied to the device (power-on-reset) or power is cycled
- A sequence event occurs as a result of a configured rail alarm event
- RESTART command is issued over the I<sup>2</sup>C bus

During RESET, the following takes place:

- All ENx and GPOx pins are placed in a high-impedance state
- All internal timers are reset to zero
- The I<sup>2</sup>C address pins (ADDR1-ADDR4) are sampled and the device address is assigned accordingly
- All ENx and GPOx pins are driven to their inactive levels
- The UCD9081 runs a checksum function to validate its memory contents
- If there are no errors, the device starts sequencing according to the current sequencer configuration

During this time, the UCD9081 does not respond to host requests made over the I<sup>2</sup>C bus.

To ensure the integrity of data within the device, the device runs a checksum function during RESET. If the configuration parameters of the device are valid, the UCD9081 begins operating according to the current sequencer configuration. If the configuration parameters are invalid, the UCD9081 overwrites the current configuration parameters with the last known good configuration and the device begins operating with these parameters. This can cause a delay in the RESET time. To establish a copy of the valid configuration, UCD9081 RESET time is delayed the first time a new configuration is loaded.

## Device Functional Modes (continued)

### 8.4.5 Voltage Reference

The analog to digital converter in the UCD9081 has a selectable voltage reference,  $V_{R+}$ . The voltage reference can either be an internally generated 2.5-V reference or an external reference derived from  $V_{CC}$ . The external reference is recommended for those systems requiring more accurate voltage readings. See [Estimating UCD9081 Reporting Accuracy Over Variations in ADC Voltage Reference](#) for information on calculating the accuracy of each reference.

### 8.4.6 Voltage Monitoring

The UCD9081 can monitor eight voltage rails through the MONx terminals of the device (MON1 to MON8). The UCD9081 samples these eight input channels and uses the selected reference to convert the voltages to digital values. These values are accessible through the I<sup>2</sup>C interface. When monitoring a voltage rail that has a nominal voltage larger than the selected reference, a resistor divider network is typically used. The design must ensure that the source impedance of the resistor network is chosen properly to maintain the accuracy of the analog to digital conversion. For more details, see [Application Information](#).

The UCD9081 allows the user to independently specify the following for each monitored rail:

- overvoltage (OV) threshold
- undervoltage (UV) threshold
- out of regulation time or glitch width (OORW)
- maximum time for regulation (MTFR)

The MTFR is used to determine whether or not a rail starts successfully after being enabled.

The UCD9081 also has the ability to ignore glitches. Glitches are fault conditions that last less than the specified OORW for that rail. Ignoring glitches may be useful in the case where the power supply is known to be noisy but still operates well. Ignoring glitches does not affect the monitoring capability of the UCD9081 with respect to detecting sustained UV or OV faults. It simply prevents the UCD9081 from logging glitch faults to the error log.

### 8.4.7 Rail Shutdown

Rail (or GPO) shutdown is the act of setting the ENx (or GPOx) pin to a state which disables the associated power supply output. A rail can shutdown for one of the following reasons:

- A fault condition on the rail itself
- A fault condition on a parent rail resulting in a shutdown
- An I<sup>2</sup>C shutdown command

Each rail and GPO can be independently configured to shutdown according to a user-specified time delay from 0 ms to 4095 ms. This is referred to as the system shutdown configuration.

### 8.4.8 Alarm Processing

Each rail can be independently configured to respond to an alarm or fault in a variety of ways. A fault can be an UV condition, OV condition, or a rail that did not start (MTFR exceeded before UV threshold achieved). The options for alarm processing are as follows:

- Ignore
- Log only
- Retry n times (n = 0,1,2,3,4)
- Retry continuously
- Sequence (immediately)
- Sequence after shutdown

In addition to these options, a rail can be independently configured to log errors to FLASH to aid in failure analysis. For more details, see [Error Logging](#).

## Device Functional Modes (continued)

### 8.4.8.1 Ignore

The UCD9081 can be configured to ignore all alarms on the rail. This is the recommended option for all unused power supply rails on the UCD9081.

### 8.4.8.2 Log Only

The UCD9081 can be configured to log a fault and take no additional action. For more information, see [Error Logging](#).

### 8.4.8.3 Retry n Times

The UCD9081 can be configured to attempt to restart a rail up to n times (n = 0,1,2,3, or 4) in response to a sustained fault condition. With this option, the user can also specify which rails and GPOs are dependent upon the configured rail. When a sustained fault is detected, the faulty rail is disabled and re-enabled the desired number of times. The rail remains enabled for the specified MTRF before attempting another retry. If the rail does not achieve regulation after the desired number of retries, all user-specified dependent rails and GPOs are shutdown according to the times specified in the system shutdown configuration. If any of the dependent rails have other rails or GPOs marked as dependents, those dependent rails or GPOs are also forced to shutdown regardless of their alarm processing configurations.

### 8.4.8.4 Retry Continuously

The UCD9081 can be configured to continuously attempt to restart a faulty rail. When the UCD9081 detects a sustained fault condition on the configured rail, the rail is disabled and then re-enabled. The rail remains enabled for the specified MTRF. The retry process repeats for this rail until it properly achieves regulation.

### 8.4.8.5 Sequence

The UCD9081 can be configured to sequence the entire system in response to a sustained fault condition. When the UCD9081 detects a fault on the configured rail, all rails and GPOs are shutdown immediately and UCD9081 RESET occurs (see [Device Reset](#)). For this configuration, a shutdown according to the delay times specified by the system shutdown configuration does not occur prior to UCD9081 RESET.

### 8.4.8.6 Sequence After Shutdown

Sequence after shutdown is an option that can be used in conjunction with [Retry n Times](#). When a fault occurs on the configured rail, this option forces a UCD9081 RESET to occur after the procedure outlined in [Retry n Times](#) takes place. If a rail is configured for sequence after shutdown and is forced to shutdown due to a fault on a parent rail, a sequence after shutdown takes place.

## 8.4.9 Error Logging

The UCD9081 is capable of logging errors in two ways. The first method uses an eight-deep FIFO located in volatile memory (SRAM) of the UCD9081. Error conditions are posted to the ERROR registers according to the configuration for that rail. The UCD9081 logs the type of error, the time (from Reset) when the error occurred, the rail number, and the rail voltage. If the user has specified *ignore glitches* as an option for the faulty rail, glitches are not posted to the error log. If the user has specified *ignore* as the alarm response for the faulty rail, no errors are posted to the error log for that rail. All other alarm responses result in the error condition being logged. Due to the unknown latency of the host extracting data from the FIFO, the UCD9081 only posts to the FIFO if it has room to write. There is no impact to the monitoring operation of the UCD9081 if this FIFO is full and cannot be written.

The second method of error logging uses the non-volatile memory (FLASH) of the UCD9081. Similar to the error log in SRAM, faults are posted for all rails that have the appropriate alarm processing options selected. In this case, errors are posted to both the SRAM log and the FLASH log. The UCD9081 is capable of recording up to eight entries in the flash error log. Again, the UCD9081 only posts to the log if there is room to write. There is no impact to the monitoring operation of the UCD9081 if the error log is full and cannot be written.

## Device Functional Modes (continued)

To provide flexibility for a variety of systems, the UCD9081 has two modes for non-volatile error logging. The first mode configures the UCD9081 to hold in RESET when entries are present in the FLASH error log. This is advantageous in systems where a master I<sup>2</sup>C device is available to read the error log following a critical system failure. When configured for this mode, the UCD9081 checks for a non-empty FLASH error log during RESET. If there are entries in the FLASH error log, the device waits for a host to clear the error log before sequencing the device. For information on clearing the FLASH error log, see the section on [Resetting the Flash Error Log](#).

The second mode allows the UCD9081 to sequence (following a RESET of the device) regardless of whether or not there are entries present in the FLASH error log. This is useful in systems with no master I<sup>2</sup>C device, or where power cycles are common and not due to system failure.

For information on reading the error logs in each mode, see [Register Maps](#).

### 8.4.10 Brownout

The brownout circuit is implemented to provide the proper internal reset signal to the device during power on and power off.

## 8.5 Programming

### 8.5.1 I<sup>2</sup>C Interface

The UCD9081 power-supply sequencer has a 100 kHz, slave mode I<sup>2</sup>C interface for communication with an I<sup>2</sup>C master. The I<sup>2</sup>C master uses this interface to configure and monitor the UCD9081. The master must support clock stretching to properly communicate with the UCD9081.

### 8.5.2 Configuring and Monitoring the UCD9081

The UCD9081 supports both configuration and monitoring using its I<sup>2</sup>C slave interface. A Microsoft Windows™ GUI is available for configuring and monitoring the UCD9081. This GUI can be downloaded from the TI website at [www.ti.com](http://www.ti.com).

For monitoring the sequencer, an I<sup>2</sup>C memory map allows an I<sup>2</sup>C host to perform memory-mapped reads (and in some cases writes) to obtain status information from the UCD9081. For instance, all rails can report their voltage through the I<sup>2</sup>C memory map. For information on which parameters are available through the I<sup>2</sup>C memory map, see [Register Maps](#).

To change configuration parameters of the sequencer, a different mechanism is used. The entire set of configuration parameters must be written at one time to the device as one large transaction over the I<sup>2</sup>C interface. This ensures that the configuration of the device is consistent at any given time. The process for configuring the UCD9081 is described in [Configuring the UCD9081](#).

The UCD9081 is compatible with 3.3-V IO ports of microcontrollers, TMS320™ DSP family as well as ASICs. The UCD9081 is available in a plastic 32-pin VQFN package (RHB).

### 8.5.3 Resetting the Flash Error Log

The UCD9081 can be configured to log errors on a critical voltage rail to internal FLASH memory. This mechanism permits the error log to be read after the device has been reset, or if a loss of power causes non-volatile memory to be cleared. As outlined in [Error Logging](#), there are two modes for using this feature.

The first mode holds the UCD9081 in RESET (following a RESET of the device) if entries are present in the FLASH error log. This allows the user to successfully read and clear the FLASH error log before sequencing the system. When using this mode, the UCD9081 does not sequence until the FLASH error log is cleared. To clear the FLASH error log and sequence the device, perform the following steps:

- Write FLASHLOCK register to a value of 0x02
- Write WADDR register to a value of 0x1000
- Write WDATA register to a value of 0xBADC
- Write WADDR register to a value of 0x107E
- Write WDATA register to a value of 0xBADC
- Write FLASHLOCK register to a value of 0x00

## Programming (continued)

- Write RESTART register to a value of 0x00

The second mode allows the UCD9081 to sequence (following a RESET of the device) regardless of whether or not there are entries present in the FLASH error log. When using this mode, the user still may wish to clear the FLASH error logs some time after RESET. To do this, perform the following steps:

- Write FLASHLOCK register to a value of 0x02
- Write WADDR register to a value of 0x1000
- Write WDATA register to a value of 0xBADC
- Write WADDR register to a value of 0x107E
- Write WDATA register to a value of 0xBADC
- Write FLASHLOCK register to a value of 0x00

Clearing the FLASH error log during run-time causes a delay in monitoring.

### 8.5.4 Configuring the UCD9081

The UCD9081 has many different configurable parameters such as sequencing options, alarm processing options, and rail dependencies. A Microsoft Windows™ GUI is available for selecting and generating the necessary configuration parameters. The UCD9081 GUI can be downloaded from [www.ti.com](http://www.ti.com) in the product folder. See *UCD9081 EVM User's Guide* (SLVU249) for details on installing and using the GUI. Once the user-specific configuration parameters are selected, the GUI generates a hex file that can be loaded into the flash memory of the UCD9081 through the I<sup>2</sup>C interface.

#### NOTE

Because loading a new configuration requires writing to FLASH memory, the UCD9081 does not monitor the MONx inputs while the configuration parameters are being updated.

#### NOTE

The enable and digital I/O pins of the UCD9081 are in a high impedance state when the device is not configured (Texas instruments delivers the device in this state).

To download the configuration parameters generated by the GUI into the UCD9081, a contiguous block of configuration information is sent to the device through the I<sup>2</sup>C interface. This block is 512 bytes long and starts at address 0xE000.

This 512-byte block of configuration information is sent to the device in multiple segments. The segment size can range from 2 to 32 bytes at one time, and must be a multiple of 2 bytes. That is, a master can send 256 2-byte segments or 32 16-byte segments, and so on. All the segments must be sent back-to-back in the proper sequence, and this operation must be completed by sending the last segment so that the last byte of the 512-byte block is written. If this is not done, the UCD9081 is in an unknown state and does not function as designed.

The process for sending the configuration information to the UCD9081 is as shown in [Figure 8](#).

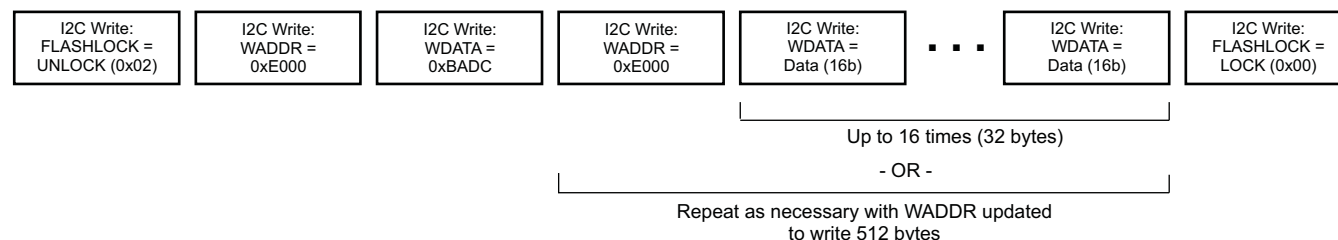

**Figure 8. Configuration Information**

## Programming (continued)

As shown in [Figure 8](#), the process for updating the configuration of the UCD9081 is as follows:

1. Unlock flash memory by writing the value 0x02 to the FLASHLOCK register
2. Write the address of the configuration section of memory (WADDR = 0xE000)
3. Write the constant 0xBADC to update memory (WDATA = 0xBADC)
4. Write the address of the configuration section of memory again (WADDR = 0xE000)
5. Write the data (WDATA = <varies>). Repeat steps 4 and 5 as necessary, depending on the data segment size used, to write 512 bytes. Increment the address as necessary.
6. Lock flash memory after the last byte of the last segment is written by writing the value 0x00 to the FLASHLOCK register

At the conclusion of this process, the configuration of the UCD9081 is updated with the configuration changes, as represented by the values from the data segments. See [UCD9081 Programming Guide](#) (SLVA275) for more details on programming the UCD9081.

### 8.5.5 User Data

User data (128 bytes) can be stored in the UCD9081 FLASH memory at location 0x1080 to 0x10FF. Writes to the User Data section of memory are performed as follows:

1. Unlock flash memory by writing the value 0x02 to the FLASHLOCK register
2. Write the address of the USER DATA section of memory (WADDR = 0x1080)
3. Write the constant 0xBADC to update memory (WDATA = 0xBADC)
4. Write the address of the USER DATA section of memory again (WADDR = 0x1080)
5. Write the data (WDATA = <varies>). Repeat steps 4 and 5 as necessary depending on the data segment size used. Increment the address as necessary.
6. Lock flash memory after the last byte of the last segment is written by writing the value 0x00 to the FLASHLOCK register

To read the User Data section of memory, follow the procedure for reading memory outlined in [WADDR and WDATA](#).

### 8.5.6 I<sup>2</sup>C Address Selection

The UCD9081 supports 7-bit I<sup>2</sup>C addressing. The UCD9081 selects an I<sup>2</sup>C address by sampling the logic level of the four digital inputs to the device (ADDR1–ADDR4) during the RESET interval. When the UCD9081 is released from RESET, the ADDR<sub>x</sub> logic levels are latched and the I<sup>2</sup>C address is assigned as shown in [Figure 9](#).

A7 = 1	A6 = 1	A5 = 0	A4 = ADDR4/GPO4	A3 = ADDR3/GPO3	A2 = ADDR2/GPO2	A1 = EN8/ADDR1/GPO1
--------	--------	--------	-----------------	-----------------	-----------------	---------------------

**Figure 9. I<sup>2</sup>C Address = 0x60–0x6F**

External pullup or pulldown resistors are required to configure the I<sup>2</sup>C address; the UCD9081 does not have internal bias resistors. The 7-bit I<sup>2</sup>C address refers to the address bits only, not the read/write bit in the first byte of the I<sup>2</sup>C protocol. The base I<sup>2</sup>C address is 0x60 and the I<sup>2</sup>C general call address (0x00) is not supported.

After the initialization process of the UCD9081 is complete, these four pins can be used for general-purpose outputs.

### 8.5.7 I<sup>2</sup>C Transactions

The UCD9081 can be configured and monitored through I<sup>2</sup>C memory-mapped registers. Registers that are configurable (can be written) through an I<sup>2</sup>C write operation are implemented using an I<sup>2</sup>C unidirectional data transfer, from the master to slave, with a stop bit between transactions.

8.5.7.1 I<sup>2</sup>C Unidirectional Transfer

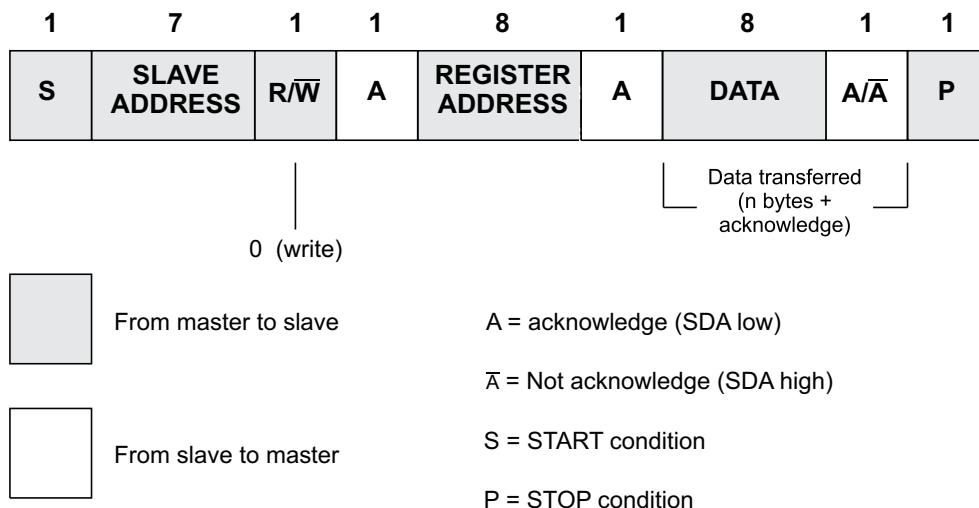

Figure 10. I<sup>2</sup>C Register Access With START or STOP

Registers that can be read are implemented using an I<sup>2</sup>C read operation, which can use the I<sup>2</sup>C combined format that changes data direction during the transaction. This transaction uses an I<sup>2</sup>C repeated START during the direction change.

8.5.7.2 I<sup>2</sup>C Combined Format

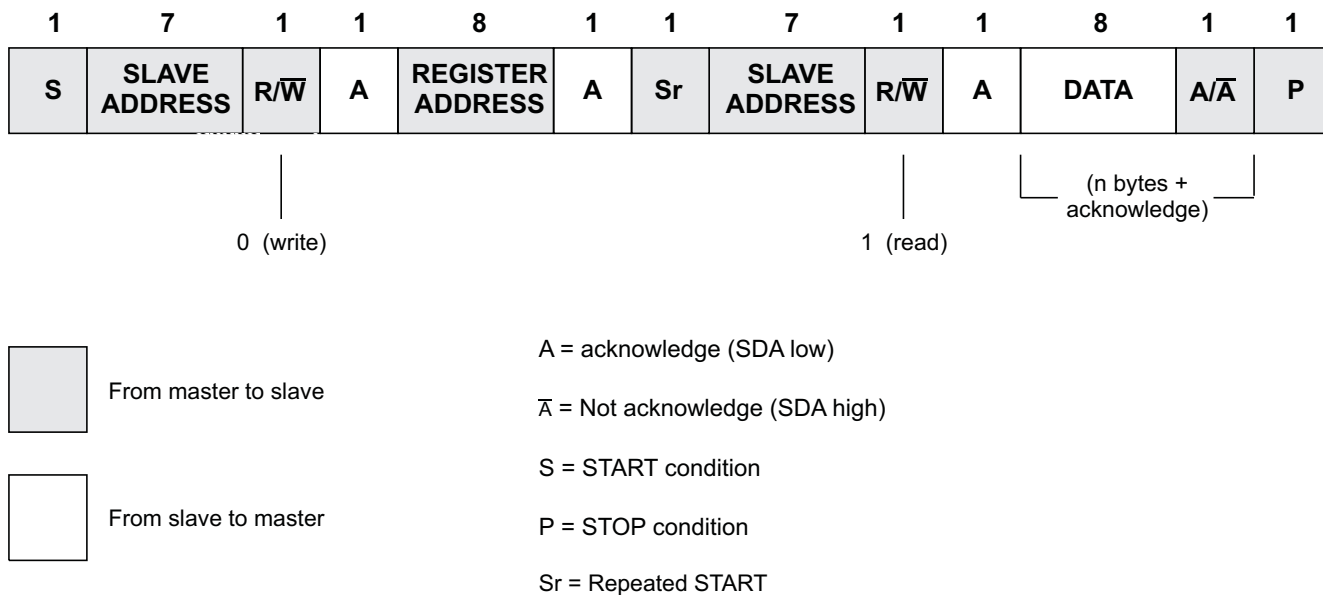

Figure 11. I<sup>2</sup>C Register Access With Repeated START

The UCD9081 also supports a feature that auto-increments the register address pointer for increased efficiency when accessing sequential blocks of data. It is not necessary to issue separate I<sup>2</sup>C transactions.

## 8.6 Register Maps

The UCD9081 allows all monitoring of the system through the I<sup>2</sup>C interface on the device. The following is the memory map of the supported registers in the system. The detail of each of these registers is given in the next section as well.

The UCD9081 supports functionality to increment the I<sup>2</sup>C register address value automatically when a register is being accessed to more efficiently access blocks of like registers. [Table 1](#) also shows the amount that the register address is incremented for each register access.

**Table 1. Register Access Adjustment**

REGISTER NAME	ADDRESS	ACCESS	ADJUSTMENT AFTER ACCESS
RAIL1H	0x00	r	+1 (0x01)
RAIL1L	0x01	r	+1 (0x02)
RAIL2H	0x02	r	+1 (0x03)
RAIL2L	0x03	r	+1 (0x04)
RAIL3H	0x04	r	+1 (0x05)
RAIL3L	0x05	r	+1 (0x06)
RAIL4H	0x06	r	+1 (0x07)
RAIL4L	0x07	r	+1 (0x08)
RAIL5H	0x08	r	+1 (0x09)
RAIL5L	0x09	r	+1 (0x0A)
RAIL6H	0x0A	r	+1 (0x0B)
RAIL6L	0x0B	r	+1 (0x0C)
RAIL7H	0x0C	r	+1 (0x0D)
RAIL7L	0x0D	r	+1 (0x0E)
RAIL8H	0x0E	r	+1 (0x0F)
RAIL8L	0x0F	r	-15 (0x00)
ERROR1	0x20	r	+1 (0x21)
ERROR2	0x21	r	+1 (0x22)
ERROR3	0x22	r	+1 (0x23)
ERROR4	0x23	r	+1 (0x24)
ERROR5	0x24	r	+1 (0x25)
ERROR6	0x25	r	-5 (0x20)
STATUS	0x26	r	0 (0x26)
VERSION	0x27	r	0 (0x27)
RAILSTATUS1	0x28	r	+1 (0x29)
RAILSTATUS2	0x29	r	-1 (0x28)
FLASHLOCK	0x2E	rw	0 (0x2E)
RESTART	0x2F	w	0 (0x2F)
WADDR1	0x30	rw	+1 (0x31)
WADDR2	0x31	rw	-1 (0x30)
WDATA1	0x32	rw	+1 (0x33)
WDATA2	0x33	rw	-1 (0x32)

### 8.6.1 Register Descriptions

The following are the detailed descriptions of each of the UCD9081 I<sup>2</sup>C registers.

The following register bit conventions are used. Each register is shown with a key indicating the accessibility of each bit, and the initial condition after device initialization.

### 8.6.2 RAIL

For each of eight voltage rails, the UCD9081 has two registers that contain the rolling average voltage for the associated rail as measured by the device. This average voltage is maintained in real-time by the UCD9081 and is calculated as the output of a 4-TAP FIR filter. There are two registers for each voltage rail. One holds the least-significant 8 bits of the voltage and the other the most-significant 2 bits of the voltage. This is shown in [Table 2](#).

**Table 2. RAIL Register**

REGISTER NAME	ADDRESS	REGISTER CONTENTS
RAIL1H	0x00	RAIL1 voltage, bits 9:8
RAIL1L	0x01	RAIL1 voltage, bits 7:0
RAIL2H	0x02	RAIL2 voltage, bits 9:8
RAIL2L	0x03	RAIL2 voltage, bits 7:0
RAIL3H	0x04	RAIL3 voltage, bits 9:8
RAIL3L	0x05	RAIL3 voltage, bits 7:0
RAIL4H	0x06	RAIL4 voltage, bits 9:8
RAIL4L	0x07	RAIL4 voltage, bits 7:0
RAIL5H	0x08	RAIL5 voltage, bits 9:8
RAIL5L	0x09	RAIL5 voltage, bits 7:0
RAIL6H	0x0A	RAIL6 voltage, bits 9:8
RAIL6L	0x0B	RAIL6 voltage, bits 7:0
RAIL7H	0x0C	RAIL7 voltage, bits 9:8
RAIL7L	0x0D	RAIL7 voltage, bits 7:0
RAIL8H	0x0E	RAIL8 voltage, bits 9:8
RAIL8L	0x0F	RAIL8 voltage, bits 7:0

A rail voltage is read with a 16b access. The auto-increment feature of the UCD9081 allows multiple rail voltages to be read with a single access.

A rail voltage is provided as a 10-bit binary value in an unsigned format, as shown in [Figure 12](#).

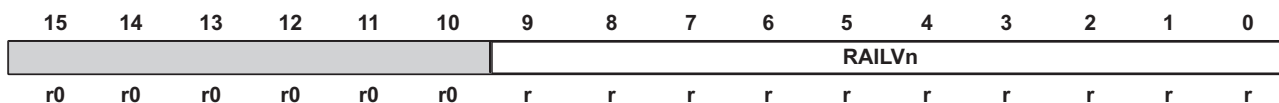

**Figure 12. RAILVn Binary**

The following formulas can be used to calculate the actual measured rail voltage.

Use [Equation 1](#) for the actual measured rail voltage without an external voltage divider.

$$V_{RAILn} = \frac{RAILVn}{1024} \times V_{R+} \tag{1}$$

Use [Equation 2](#) for the actual measured rail voltage with an external voltage divider.

$$V_{RAILn} = \frac{RAILVn}{1024} \times V_{R+} \times \frac{R_{PULLDOWN} + R_{PULLUP}}{R_{PULLDOWN}} \tag{2}$$

### 8.6.3 ERROR

Error conditions are logged by the UCD9081 and are accessible to the user through reading the ERROR register. This is a 6-byte register is shown in [Figure 13](#).

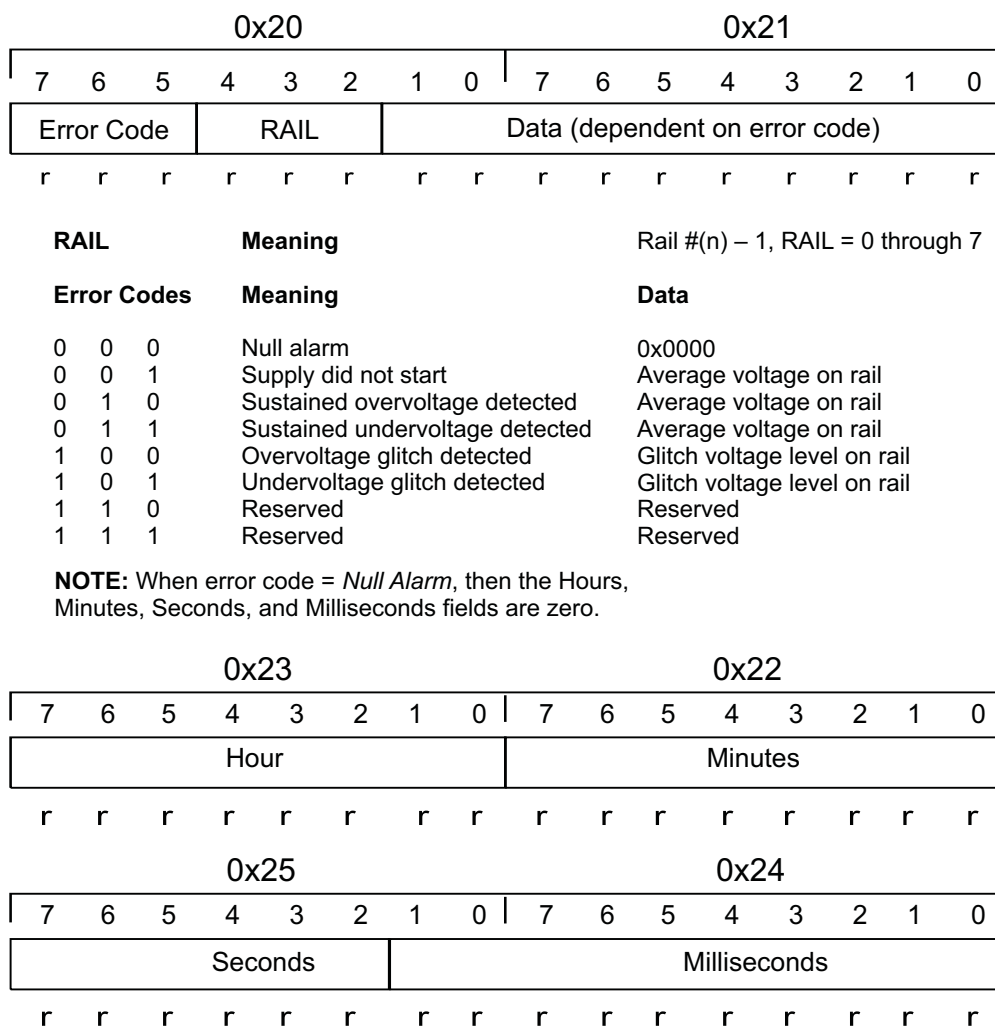

**Figure 13. ERROR Register**

Faults encountered during operation post error logs as described in [Error Logging](#). This register set is used for reading the SRAM error log. They can also be used to read the FLASH error log when the UCD9081 is held in RESET. If the error log is empty, the ERROR register set returns all 0's (NULL ALARM) when read.

The values in registers 0x22 through 0x25 are reset to a value of 0 during UCD9081 RESET.

### 8.6.4 STATUS

STATUS is an 8-bit read-only register. This register provides real-time status information about the state of the UCD9081. Figure 14 shows the bit definitions.

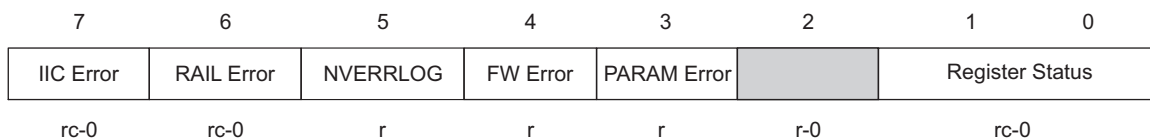

IIC Error	Meaning	Register Status	Meaning
0	No I <sup>2</sup> C PHY layer error	00	No error
1	I <sup>2</sup> C PHY layer error	01	Invalid address
		10	Read access error
		11	Write access error

RAIL Error	Meaning
0	No RAIL error pending
1	RAIL error pending

NVERRLOG	Meaning
0	ERROR points to run-time error log
1	ERROR points to non-volatile log (if held in RESET) and entries present in non-volatile log

FW Error	Meaning
0	No Error (normal operation)
1	Device firmware error detected, device is idle

PARAM Error	Meaning
0	No Error (normal operation)
1	Parameters invalid, last config loaded

**Figure 14. STATUS Register**

Reading of the STATUS register clears the register except for the NVERRLOG bit, which is maintained until the device is reset. Descriptions of the different errors are below.

The IICERROR bit is set when an I<sup>2</sup>C access fails. This is most often a case where the user has accessed an invalid address or performed an illegal number of operations for a given register (for example, reading 3 bytes from a 2-byte register). In the event of an I<sup>2</sup>C error when the IICERROR is set, bits 1:0 of the STATUS register further define the nature of the error as shown in the preceding figure.

The RAIL error bit is set to alert the user to an issue with one of the voltage rails. When this bit is set, the user is advised to query the RAILSTATUS register to further ascertain which RAIL input(s) have an issue. The user may then query the ERROR registers to get further information about the nature of the error condition.

The NVERRLOG bit is set to 1 upon device RESET if the UCD9081 contains entries in the FLASH error log. This bit is the only bit that is not automatically cleared by a read of the STATUS register; this bit is only cleared during UCD9081 RESET (if the nonvolatile error log is empty).

The FW Error bit is set to 1 if the device firmware memory contents are corrupted.

The PARAM Error bit is set to 1 if the contents of the UCD9081 configuration memory are invalid. If this occurs, the UCD9081 loads the last known good configuration to ensure device reliability.

### 8.6.5 VERSION

The VERSION register provides the user with access to the device revision of the UCD9081. The format of this register is a nibble-based major/minor format as shown in [Figure 15](#).

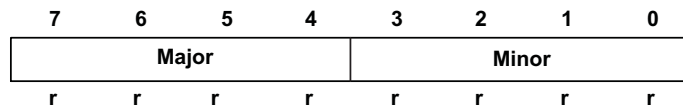

**Figure 15. VERSION Major/Minor Register**

### 8.6.6 RAILSTATUS

The RAILSTATUS1 and RAILSTATUS2 registers are two 8-bit read-only registers that provide a bit mask to represent the error status of the rails as indicated in [Figure 16](#).

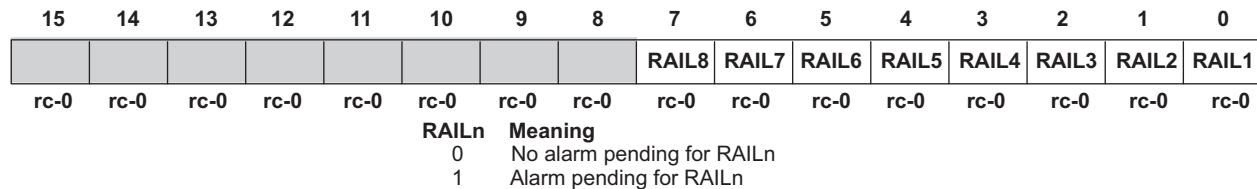

**Figure 16. RAILSTATUS Registers**

Bits 15:8 are RAILSTATUS1 and bits 7:0 are RAILSTATUS2. These are read as two 8-bit registers or as a single 16-bit register.

If a bit is set in these registers, then the ERROR register is read to further ascertain the specific error. Bits in the RAILSTATUS1 and RAILSTATUS2 registers are cleared when read.

### 8.6.7 FLASHLOCK

The FLASHLOCK register is used to lock and unlock the configuration memory on the UCD9081 when updating the configuration. [Configuring the UCD9081](#) details this process.

[Figure 17](#) shows the format for the FLASHLOCK register.

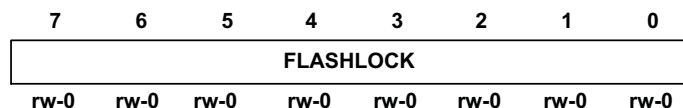

**FLASHLOCK**

0x00	Lock flash (default)
0x01	Flash is being updated
0x02	Unlock flash (before configuration)

**Figure 17. FLASHLOCK Register**

### 8.6.8 RESTART

The RESTART register provides the capability for the I<sup>2</sup>C host to force a RESET or Shutdown of the UCD9081. This is an 8-bit register, and when a value of 0x00 is written to the register, the UCD9081 RESET occurs and the rails are re-sequenced. To respond to this I<sup>2</sup>C request properly, there is a 50-μs delay before the system is restarted, so that the I<sup>2</sup>C ACK can take place.

When a value of 0xC0 is written to the register, all rails and GPOs are shutdown according to the time delays specified in the system shutdown configuration. Once this procedure is complete, the UCD9081 continues monitoring.

### 8.6.9 WADDR and WDATA

To update the configuration on the UCD9081, four registers are provided. WADDR2 (address 15:8) and WADDR1 (address bits 7:0) specify the memory address. WDATA2 (data bits 15:8) and WDATA1 (data bits 7:0) specify the data written to or read from that memory address.

Figure 18 shows the format for the WADDR registers.

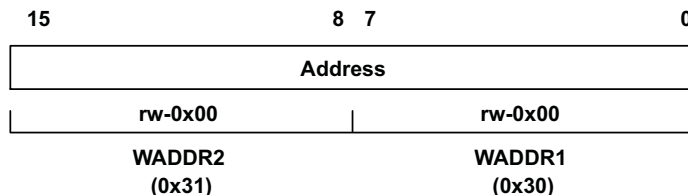

Figure 18. WADDR Registers

To set the memory address that is accessed, write the LSB of the address to the WADDR1 register and the MSB of the address to the WADDR2 register. For example, to write the address 0x1234 to the device, set WADDR1 = 0x34 and WADDR2 = 0x12. Because these addresses support the auto-increment feature, the user can perform a single 16-bit write to WADDR1 to write the entire address.

Figure 19 shows the format for the WDATA registers.

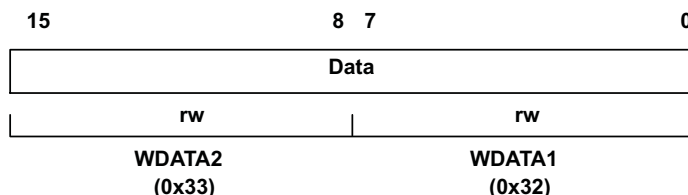

Figure 19. WDATA Registers

To set the value of the data that is written to the UCD9081, write the LSB of the data to the WDATA1 register and the MSB of the data to the WDATA2 register. For example, to write the data 0xBEEF to the device, set WDATA1 = 0xEF and WDATA2 = 0xBE. Because these addresses support the auto-increment feature, the user can perform a single 16-bit write to WDATA1 to write the entire data. To read the value of the data at the specified address, read the LSB from WDATA1 and the MSB from WDATA2.

These registers are used for updating the UCD9081 configuration as explained in [Configuring the UCD9081](#).

### 8.6.10 Reading the FLASH Error Log

There are two ways to read the FLASH error log in the UCD9081. While the device is in RESET and the NVERRLOG bit in the [STATUS](#) register is set to a 1 (FLASH error logs present), the user may use the [ERROR](#) registers to read the log. During run-time, the FLASH error log can be accessed by performing an I<sup>2</sup>C read transaction starting at address 0x1000 with a length of 48 bytes.

## 9 Application and Implementation

### NOTE

Information in the following applications sections is not part of the TI component specification, and TI does not warrant its accuracy or completeness. TI's customers are responsible for determining suitability of components for their purposes. Customers should validate and test their design implementation to confirm system functionality.

### 9.1 Application Information

#### 9.1.1 Considerations for MONX Input Series Resistance, $R_S$

$R_S$  is the series impedance between the sampled voltage source (low impedance power supply output) and the UCD9081 MONx input pin. This resistance can affect UCD9081 sampling accuracy if it is too large. In most cases (when the power supply being monitored has a lower VOUT than the UCD9081 voltage reference being used) this resistance is low and can be ignored. In cases where a voltage divider is used to scale the monitored voltage below the voltage reference, the impedance of this network must be chosen so that it does not adversely affect the analog to digital converter (ADC) conversion accuracy. The equivalent series impedance ( $R_S$ ) of the divider network is just the parallel combination of the pullup and pulldown resistors.

The UCD9081 has an internal clock (DCO) whose frequency is set by ROSC on pin 32. The DCO frequency can be affected by several factors including supply voltage and temperature. This clock is used by the ADC to set up an ADC sample or gate time ( $T_{GATE}$ ) at each MONx pin. The voltage sampled must be allowed to settle sufficiently during  $T_{GATE}$ . The settling time is affected by the UCD9081 internal capacitance and  $R_S$ . To allow for sufficient settling time over DCO frequency, supply voltage, and temperature variation, choose  $R_S < 6\text{ k}\Omega$ .

#### 9.1.2 Estimating UCD9081 Reporting Accuracy Over Variations in ADC Voltage Reference

The UCD9081 uses a 10-bit ADC. The ADC in the UCD9081 derives its reference voltage ( $V_{R+}$ ) from either the external ( $V_{CC}$  pin) or internal ( $V_{REF+}$ ) reference voltage to scale the digitally reported voltage. The least significant bit (LSB) voltage value is  $V_{LSB} = V_{R+}/2^n$  where  $n = 10$  and  $V_{R+}$  is the reference voltage used (either external  $V_{CC} = 3.3\text{ V}$  nominal, or internal  $V_{REF+} = 2.5\text{ V}$  nominal). For external  $V_{R+} = V_{CC} = 3.3\text{ V}$ ,  $V_{LSB} = 3.3 / 1024 = 3.22\text{ mV}$  and for internal  $V_{R+} = V_{REF+} = 2.5\text{ V}$ ,  $V_{LSB} = 2.5 / 1024 = 2.44\text{ mV}$ .

The error in the reported voltage is a function of the ADC linearity error(s) as well as variations in the ADC reference voltage. The total unadjusted error ( $E_{TUE}$ ) for the ADC in the UCD9081 is  $\pm 5$  LSB and the variation of the internal 2.5-V reference is  $\pm 6\%$  maximum.  $V_{TUE}$  is calculated as  $V_{LSB} \times E_{TUE}$  for the particular reference voltage used. The reported voltage error is the sum of the reference voltage error and the ADC total unadjusted error. At lower monitored voltages,  $E_{TUE}$  may dominate reported error while at higher monitored voltages  $V_{R+}$  dominates the reported error. Reported error (percent) can be calculated using [Equation 3](#).

$$RPT_{ERR} = [(1 + REFTOL) / V_{ACT}] \times [V_{R+} \times E_{TUE} / 1024 + V_{ACT}] - 1$$

where

- REFTOL is  $V_{R+}$  tolerance
- $V_{ACT}$  is actual voltage monitored (at the UCD9081 MONx pin)
- $V_{R+}$  is the nominal voltage of the ADC reference

(3)

Listed below are four examples using [Equation 3](#) to estimate reported error:

- $V_{R+} = 2.5\text{ V}$ , REFTOL = 6%,  $V_{ACT} = 0.25\text{ V}$ ,  $RPT_{ERR} = 11.2\%$
- $V_{R+} = 2.5\text{ V}$ , REFTOL = 6%,  $V_{ACT} = 2.25\text{ V}$ ,  $RPT_{ERR} = 6.6\%$
- $V_{R+} = 3.3\text{ V}$ , REFTOL = 1%,  $V_{ACT} = 0.25\text{ V}$ ,  $RPT_{ERR} = 7.5\%$
- $V_{R+} = 3.3\text{ V}$ , REFTOL = 1%,  $V_{ACT} = 2.25\text{ V}$ ,  $RPT_{ERR} = 1.7\%$

In addition to the reporting errors due to ADC and voltage reference, there can be additional errors due to divider resistor tolerance when monitoring voltages higher than  $V_{R+}$ . These errors can be added to the reporting error described above.

## 9.2 Typical Application

Figure 20 illustrates a typical power supply sequencing configuration. Power Supply 1 and Power Supply X require active low enables while Power Supply 2 and Power Supply 3 require active high enables.  $V_{OUT1}$  and  $V_{OUT3}$  exceed the selected A/D reference voltage so their outputs are divided before being sampled by the MON1 and MON3 inputs.  $V_{OUT2}$  and  $V_{OUTX}$  are within the selected A/D reference voltage so their outputs can be sampled directly by the MON2 and MON7 inputs. Figure 20 illustrates the use of the GPO digital output pins to provide status and power on reset to other system devices.

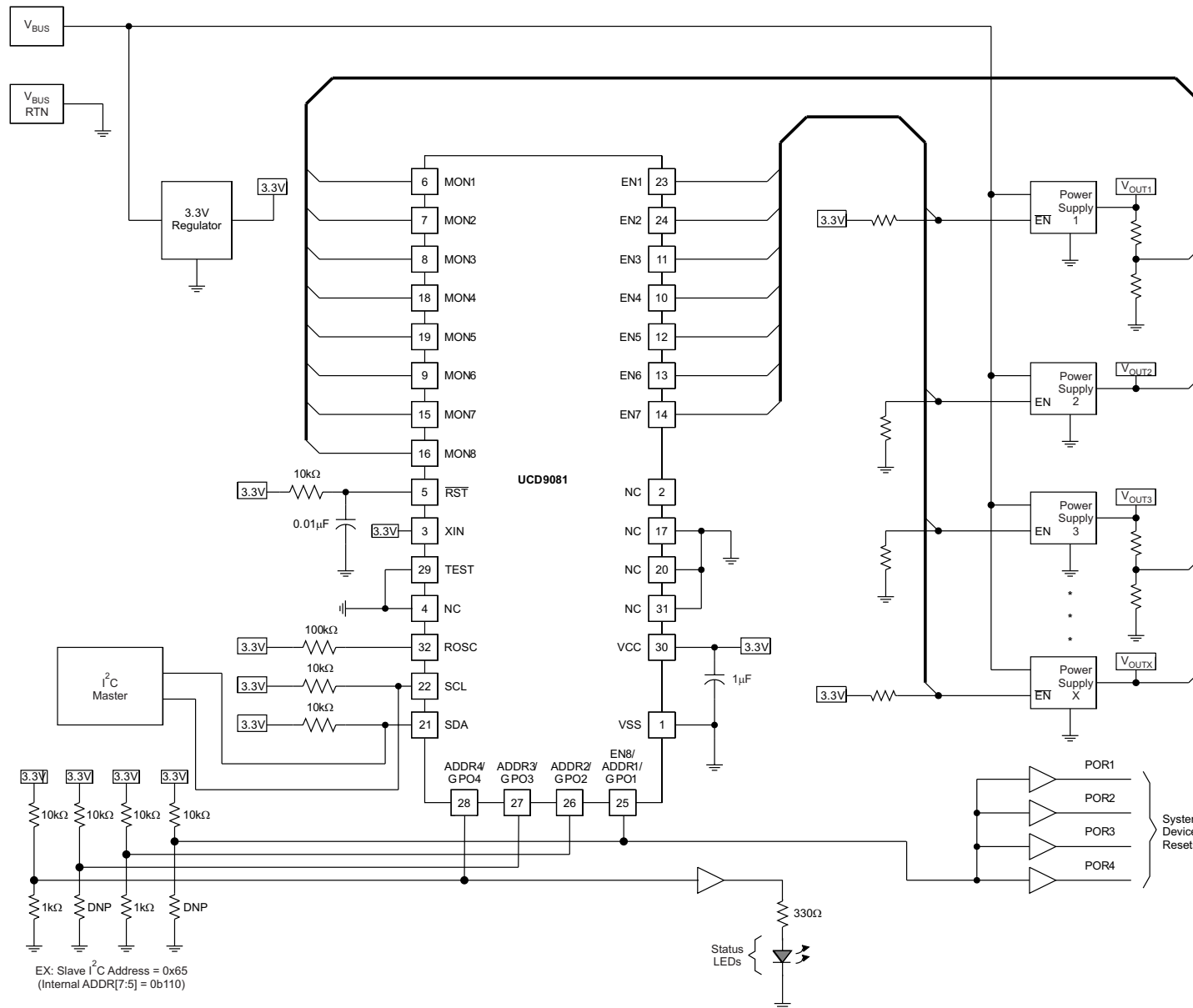

Copyright © 2016, Texas Instruments Incorporated

Figure 20. Typical Power Supply Sequencing Application

### 9.2.1 Design Requirements

RST pin must have a 10-k $\Omega$  pullup resistor to 3.3 V and 10-nF decoupling capacitor to ground. The component must be placed as close to the RST pin as possible.

### 9.2.2 Detailed Design Procedure

UCD9081 GUI can be used to design the device configuration. An USB-to-I<sup>2</sup>C Adapter from Texas Instruments can be used to connect GUI to I<sup>2</sup>C.

General design steps include:

1. General rail setup
2. Rail sequencing conditions setup
3. Alarm action (fault response) setup
4. System conditions setup
5. General GPO setup
6. GPO sequence setup

After configuration changes, click *Store to Buffer* to save the current entries to a GUI. Click *Update Parameters and Sequence* to permanently store the new configuration into the device data flash.

### 9.2.3 Application Curve

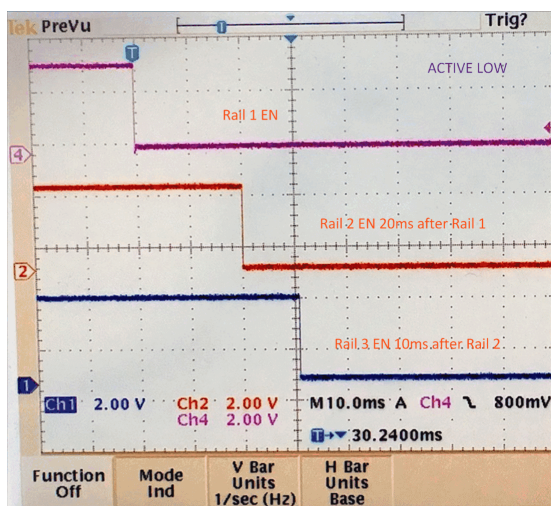

Figure 21. Example Power-On Sequence

## 10 Power Supply Recommendations

Use a 3.3-V power supply with the UCD9081.

## 11 Layout

### 11.1 Layout Guidelines

The power pad provides a thermal and mechanical interface between the device and the printed-circuit board (PCB). Connect the power pad to the device VSS pins. Pin 2 must not be connected. Pin (4, 17, 20, 31) are recommended to connect to VSS because these pins are not connected internally.

### 11.2 Layout Example

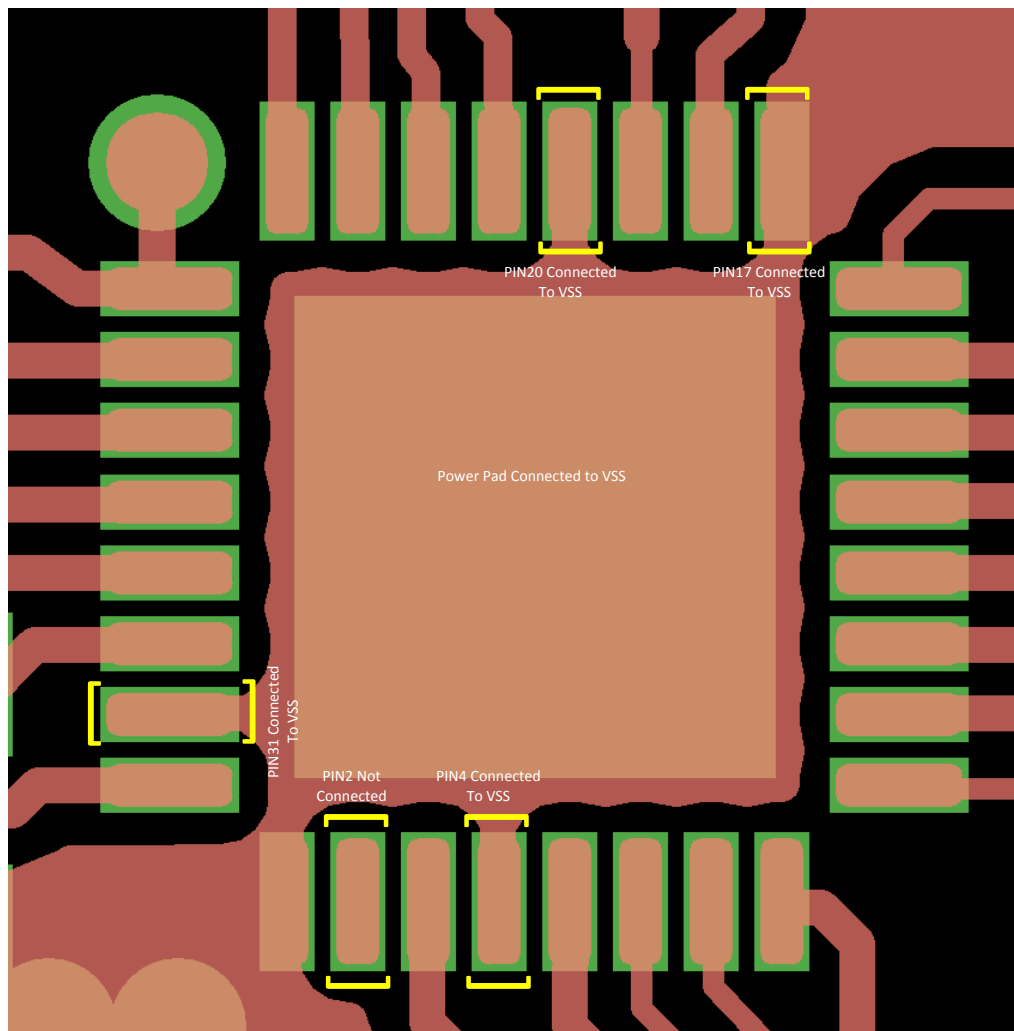

**Figure 22. UCD9081 Layout, Top Layer**

## 12 Device and Documentation Support

### 12.1 Documentation Support

#### 12.1.1 Related Documentation

For related documentation see the following:

- [UCD9081 EVM User's Guide](#) (SLVU249)
- [UCD9081 Programming Guide](#) (SLVA275)

### 12.2 Receiving Notification of Documentation Updates

To receive notification of documentation updates, navigate to the device product folder on ti.com. In the upper right corner, click on *Alert me* to register and receive a weekly digest of any product information that has changed. For change details, review the revision history included in any revised document.

### 12.3 Community Resources

The following links connect to TI community resources. Linked contents are provided "AS IS" by the respective contributors. They do not constitute TI specifications and do not necessarily reflect TI's views; see TI's [Terms of Use](#).

**TI E2E™ Online Community** *TI's Engineer-to-Engineer (E2E) Community*. Created to foster collaboration among engineers. At e2e.ti.com, you can ask questions, share knowledge, explore ideas and help solve problems with fellow engineers.

**Design Support** *TI's Design Support* Quickly find helpful E2E forums along with design support tools and contact information for technical support.

### 12.4 Trademarks

PowerPAD, TMS320, E2E are trademarks of Texas Instruments.

Windows is a trademark of Microsoft Corporation.

I<sup>2</sup>C is a trademark of Phillips Electronics.

All other trademarks are the property of their respective owners.

### 12.5 Electrostatic Discharge Caution



These devices have limited built-in ESD protection. The leads should be shorted together or the device placed in conductive foam during storage or handling to prevent electrostatic damage to the MOS gates.

### 12.6 Glossary

[SLYZ022](#) — *TI Glossary*.

This glossary lists and explains terms, acronyms, and definitions.

## 13 Mechanical, Packaging, and Orderable Information

The following pages include mechanical, packaging, and orderable information. This information is the most current data available for the designated devices. This data is subject to change without notice and revision of this document. For browser-based versions of this data sheet, refer to the left-hand navigation.

**PACKAGING INFORMATION**

Orderable Device	Status (1)	Package Type	Package Drawing	Pins	Package Qty	Eco Plan (2)	Lead/Ball Finish (6)	MSL Peak Temp (3)	Op Temp (°C)	Device Marking (4/5)	Samples
UCD9081RHBR	ACTIVE	VQFN	RHB	32	3000	Green (RoHS & no Sb/Br)	CU NIPDAU	Level-2-260C-1 YEAR	-40 to 85	UCD 9081	<a href="#">Samples</a>
UCD9081RHBRG4	ACTIVE	VQFN	RHB	32	3000	Green (RoHS & no Sb/Br)	CU NIPDAU	Level-2-260C-1 YEAR	-40 to 85	UCD 9081	<a href="#">Samples</a>
UCD9081RHBT	ACTIVE	VQFN	RHB	32	250	Green (RoHS & no Sb/Br)	CU NIPDAU	Level-2-260C-1 YEAR	-40 to 85	UCD 9081	<a href="#">Samples</a>
UCD9081RHBTG4	ACTIVE	VQFN	RHB	32	250	Green (RoHS & no Sb/Br)	CU NIPDAU	Level-2-260C-1 YEAR	-40 to 85	UCD 9081	<a href="#">Samples</a>

(1) The marketing status values are defined as follows:

**ACTIVE:** Product device recommended for new designs.

**LIFEBUY:** TI has announced that the device will be discontinued, and a lifetime-buy period is in effect.

**NRND:** Not recommended for new designs. Device is in production to support existing customers, but TI does not recommend using this part in a new design.

**PREVIEW:** Device has been announced but is not in production. Samples may or may not be available.

**OBSOLETE:** TI has discontinued the production of the device.

(2) Eco Plan - The planned eco-friendly classification: Pb-Free (RoHS), Pb-Free (RoHS Exempt), or Green (RoHS & no Sb/Br) - please check <http://www.ti.com/productcontent> for the latest availability information and additional product content details.

**TBD:** The Pb-Free/Green conversion plan has not been defined.

**Pb-Free (RoHS):** TI's terms "Lead-Free" or "Pb-Free" mean semiconductor products that are compatible with the current RoHS requirements for all 6 substances, including the requirement that lead not exceed 0.1% by weight in homogeneous materials. Where designed to be soldered at high temperatures, TI Pb-Free products are suitable for use in specified lead-free processes.

**Pb-Free (RoHS Exempt):** This component has a RoHS exemption for either 1) lead-based flip-chip solder bumps used between the die and package, or 2) lead-based die adhesive used between the die and leadframe. The component is otherwise considered Pb-Free (RoHS compatible) as defined above.

**Green (RoHS & no Sb/Br):** TI defines "Green" to mean Pb-Free (RoHS compatible), and free of Bromine (Br) and Antimony (Sb) based flame retardants (Br or Sb do not exceed 0.1% by weight in homogeneous material)

(3) MSL, Peak Temp. - The Moisture Sensitivity Level rating according to the JEDEC industry standard classifications, and peak solder temperature.

(4) There may be additional marking, which relates to the logo, the lot trace code information, or the environmental category on the device.

(5) Multiple Device Markings will be inside parentheses. Only one Device Marking contained in parentheses and separated by a "~" will appear on a device. If a line is indented then it is a continuation of the previous line and the two combined represent the entire Device Marking for that device.

(6) Lead/Ball Finish - Orderable Devices may have multiple material finish options. Finish options are separated by a vertical ruled line. Lead/Ball Finish values may wrap to two lines if the finish value exceeds the maximum column width.

**Important Information and Disclaimer:** The information provided on this page represents TI's knowledge and belief as of the date that it is provided. TI bases its knowledge and belief on information provided by third parties, and makes no representation or warranty as to the accuracy of such information. Efforts are underway to better integrate information from third parties. TI has taken and continues to take reasonable steps to provide representative and accurate information but may not have conducted destructive testing or chemical analysis on incoming materials and chemicals. TI and TI suppliers consider certain information to be proprietary, and thus CAS numbers and other limited information may not be available for release.

In no event shall TI's liability arising out of such information exceed the total purchase price of the TI part(s) at issue in this document sold by TI to Customer on an annual basis.

**TAPE AND REEL INFORMATION**

**QUADRANT ASSIGNMENTS FOR PIN 1 ORIENTATION IN TAPE**

\*All dimensions are nominal

Device	Package Type	Package Drawing	Pins	SPQ	Reel Diameter (mm)	Reel Width W1 (mm)	A0 (mm)	B0 (mm)	K0 (mm)	P1 (mm)	W (mm)	Pin1 Quadrant
UCD9081RHBR	VQFN	RHB	32	3000	330.0	12.4	5.3	5.3	1.5	8.0	12.0	Q2
UCD9081RHBT	VQFN	RHB	32	250	180.0	12.4	5.3	5.3	1.5	8.0	12.0	Q2

**TAPE AND REEL BOX DIMENSIONS**

\*All dimensions are nominal

Device	Package Type	Package Drawing	Pins	SPQ	Length (mm)	Width (mm)	Height (mm)
UCD9081RHBR	VQFN	RHB	32	3000	367.0	367.0	35.0
UCD9081RHBT	VQFN	RHB	32	250	210.0	185.0	35.0

## GENERIC PACKAGE VIEW

**RHB 32**

**VQFN - 1 mm max height**

5 x 5, 0.5 mm pitch

PLASTIC QUAD FLATPACK - NO LEAD

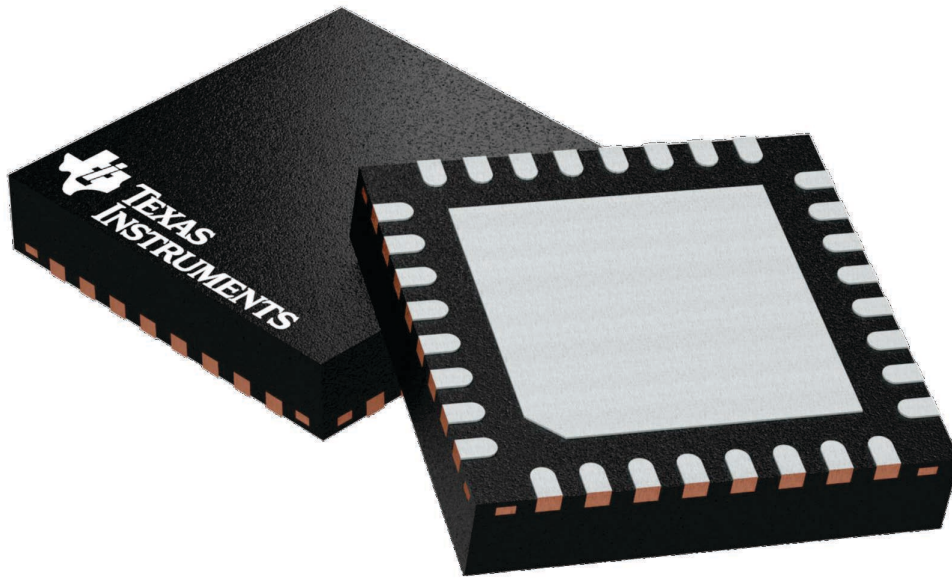

Images above are just a representation of the package family, actual package may vary.  
Refer to the product data sheet for package details.

4224745/A

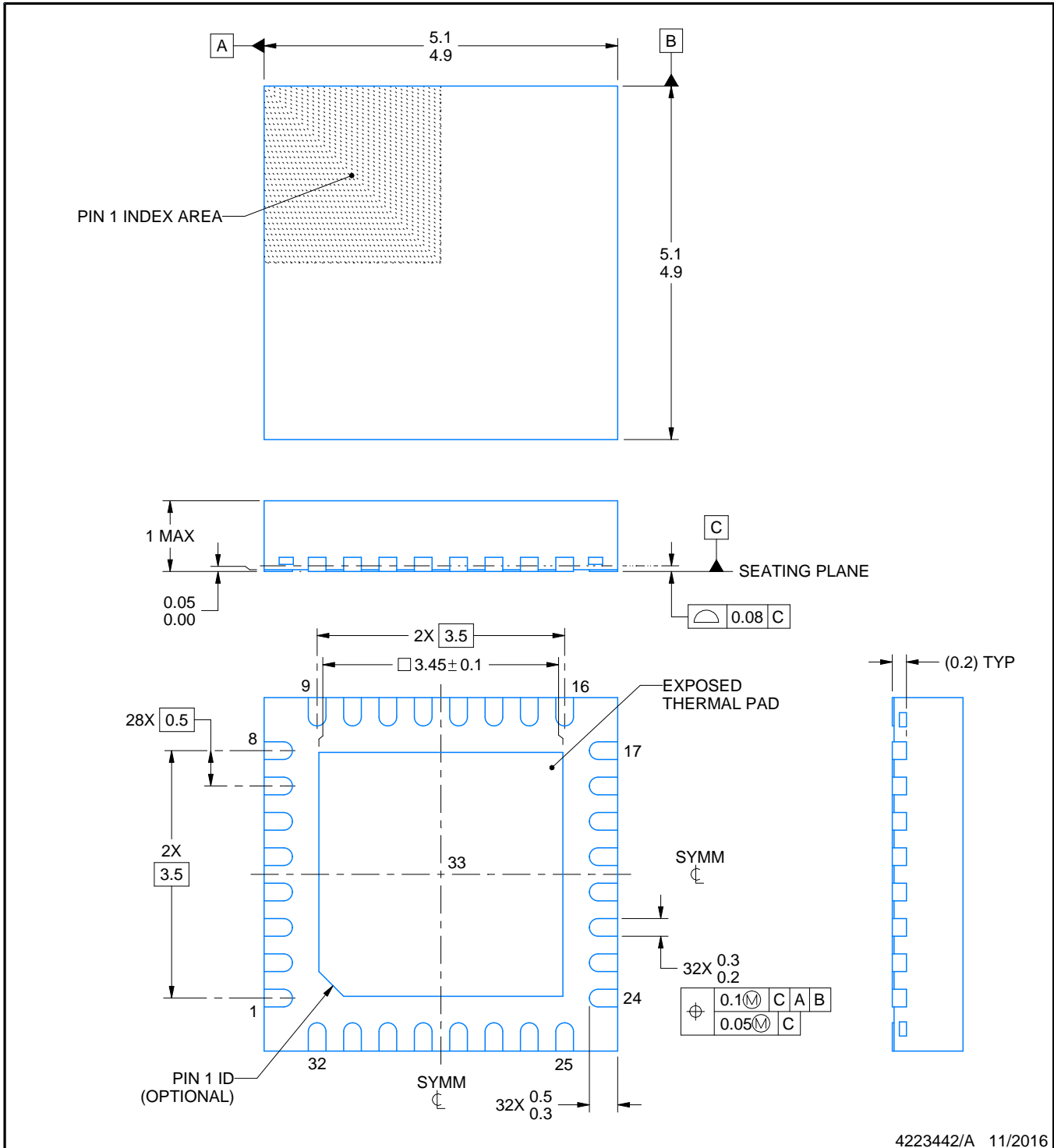
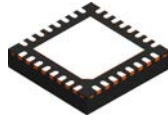

4223442/A 11/2016

NOTES:

1. All linear dimensions are in millimeters. Any dimensions in parenthesis are for reference only. Dimensioning and tolerancing per ASME Y14.5M.
2. This drawing is subject to change without notice.
3. The package thermal pad must be soldered to the printed circuit board for thermal and mechanical performance.

# EXAMPLE BOARD LAYOUT

RHB0032E

VQFN - 1 mm max height

PLASTIC QUAD FLATPACK - NO LEAD

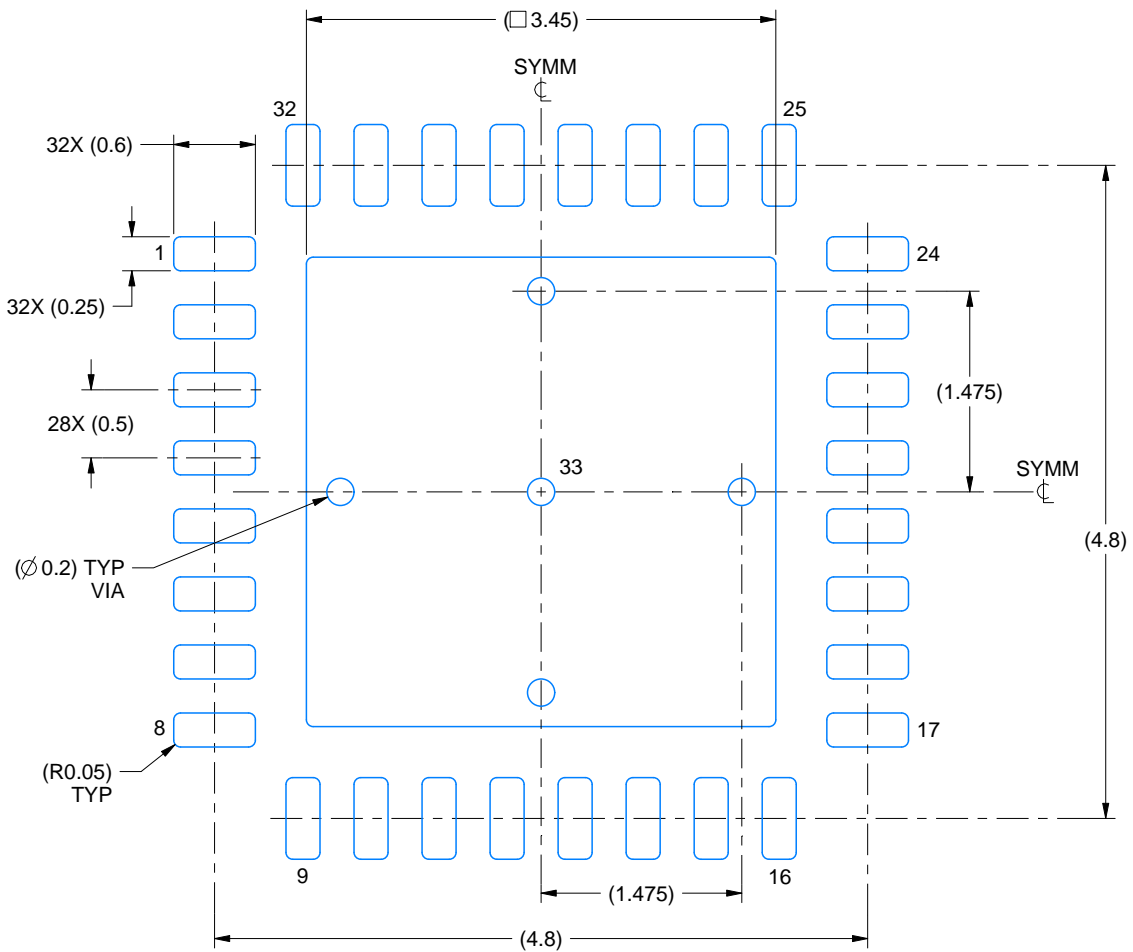

LAND PATTERN EXAMPLE  
SCALE:18X

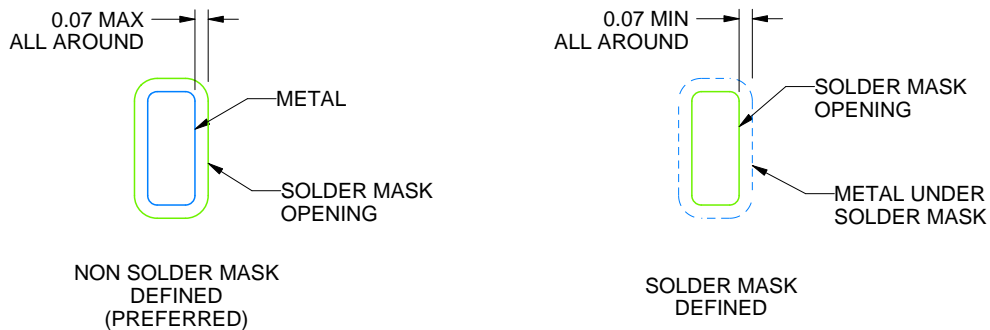

SOLDER MASK DETAILS

4223442/A 11/2016

NOTES: (continued)

4. This package is designed to be soldered to a thermal pad on the board. For more information, see Texas Instruments literature number SLUA271 ([www.ti.com/lit/sluea271](http://www.ti.com/lit/sluea271)).
5. Vias are optional depending on application, refer to device data sheet. If any vias are implemented, refer to their locations shown on this view. It is recommended that vias under paste be filled, plugged or tented.

# EXAMPLE STENCIL DESIGN

RHB0032E

VQFN - 1 mm max height

PLASTIC QUAD FLATPACK - NO LEAD

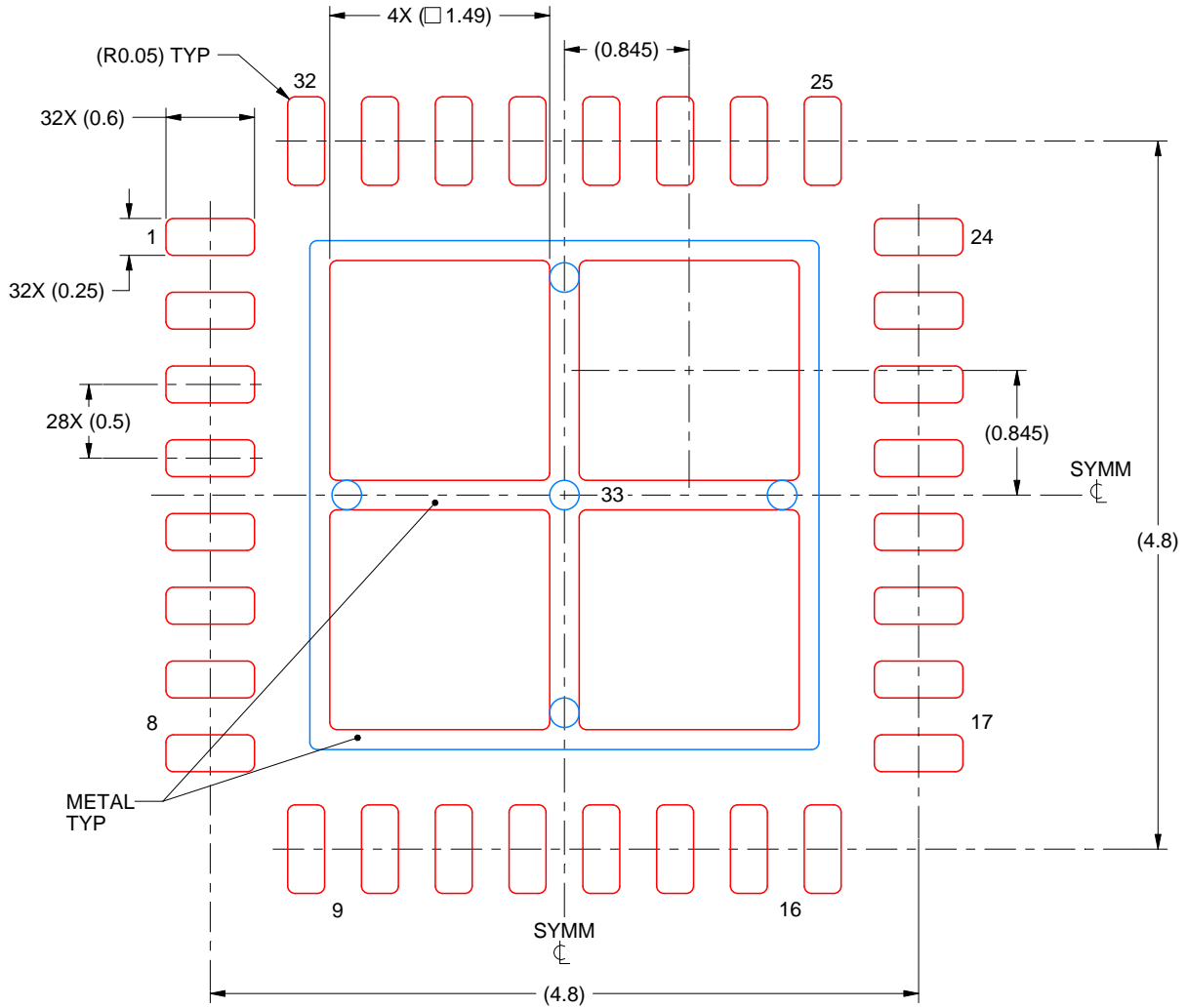

**SOLDER PASTE EXAMPLE**  
 BASED ON 0.125 mm THICK STENCIL

EXPOSED PAD 33:  
 75% PRINTED SOLDER COVERAGE BY AREA UNDER PACKAGE  
 SCALE:20X

4223442/A 11/2016

NOTES: (continued)

6. Laser cutting apertures with trapezoidal walls and rounded corners may offer better paste release. IPC-7525 may have alternate design recommendations.

## IMPORTANT NOTICE AND DISCLAIMER

TI PROVIDES TECHNICAL AND RELIABILITY DATA (INCLUDING DATASHEETS), DESIGN RESOURCES (INCLUDING REFERENCE DESIGNS), APPLICATION OR OTHER DESIGN ADVICE, WEB TOOLS, SAFETY INFORMATION, AND OTHER RESOURCES "AS IS" AND WITH ALL FAULTS, AND DISCLAIMS ALL WARRANTIES, EXPRESS AND IMPLIED, INCLUDING WITHOUT LIMITATION ANY IMPLIED WARRANTIES OF MERCHANTABILITY, FITNESS FOR A PARTICULAR PURPOSE OR NON-INFRINGEMENT OF THIRD PARTY INTELLECTUAL PROPERTY RIGHTS.

These resources are intended for skilled developers designing with TI products. You are solely responsible for (1) selecting the appropriate TI products for your application, (2) designing, validating and testing your application, and (3) ensuring your application meets applicable standards, and any other safety, security, or other requirements. These resources are subject to change without notice. TI grants you permission to use these resources only for development of an application that uses the TI products described in the resource. Other reproduction and display of these resources is prohibited. No license is granted to any other TI intellectual property right or to any third party intellectual property right. TI disclaims responsibility for, and you will fully indemnify TI and its representatives against, any claims, damages, costs, losses, and liabilities arising out of your use of these resources.

TI's products are provided subject to TI's Terms of Sale ([www.ti.com/legal/termsofsale.html](http://www.ti.com/legal/termsofsale.html)) or other applicable terms available either on [ti.com](http://ti.com) or provided in conjunction with such TI products. TI's provision of these resources does not expand or otherwise alter TI's applicable warranties or warranty disclaimers for TI products.

Mailing Address: Texas Instruments, Post Office Box 655303, Dallas, Texas 75265  
Copyright © 2019, Texas Instruments Incorporated

## Looking for pricing, stock, or lifecycle information?

Click below to explore more details on WIN SOURCE:

 [View UCD9081RHBTG4](#) on WIN SOURCE

 [Texas Instruments](#) Information

## Optimize Your Supply Chain with WIN SOURCE Solutions

-  Global Sourcing Solution
-  Obsolete Management
-  Cost Control Management
-  Shortage Management
-  Alternative Solution
-  Excess Inventory Management