

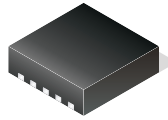

**THE DATASHEET OF
UCD74106RGMR**





Synchronous-Buck Power Stage

Check for Samples: [UCD74106](#)

FEATURES

- Fully Integrated Power Switches With Drivers for Single and Multiphase Synchronous Buck Converters
- Full Compatibility With TI Fusion Digital Power Supply Controllers, (UCD91xx and UCD92xx Families)
- Compatible With Analog Domain Controllers
- Wide Input Voltage Range:
 - 4.5 V to 18 V
 - Operational Down to 2.2-V Input With an External Bias Supply
- Up to 6-A Output Current
- Operational to 2-MHz Switching Frequency
- Current Limit With Current Limit Flag
- Onboard Regulated 6-V Driver Supply From VIN
- Thermal Protection and Monitoring

APPLICATIONS

- Digitally-Controlled Synchronous-Buck Power Stage for Single and Multi-Phase Applications
- High Efficiency Small Size Regulators for Desktop, Server, Telecom and Notebook Applications
- Synchronous-Buck Power Stages

DESCRIPTION

The UCD74106 is a complete power system ready to drive a buck power supply (Figure 1). High-side MOSFETs, low-side MOSFETs, drivers, current sensing circuitry and necessary protection functions are all integrated into one monolithic solution to facilitate minimum size and maximum efficiency. Driver circuits provide high charge and discharge current for the high-side NMOS switch and the low-side NMOS synchronous rectifier in a synchronous buck circuit. The MOSFET gates are driven to 6.25 V by an internally regulated V_{GG} supply. The internal V_{GG} regulator can be disabled to permit the user to supply an independent gate drive voltage. This flexibility allows a wide power conversion input voltage range of 2.2 V to 18 V. Internal Under Voltage Lockout (UVLO) logic insures V_{GG} is good before allowing chip operation.

A drive logic block allows operation in one of two modes. In synchronous mode, the logic block uses the PWM signal to control both the high-side and low-side gate drive signals. Dead time is optimized to prevent cross conduction. The synchronous rectifier enable (SRE) pin controls whether or not the low-side FET is turned on when the PWM signal is low.

Simplified Application Diagram

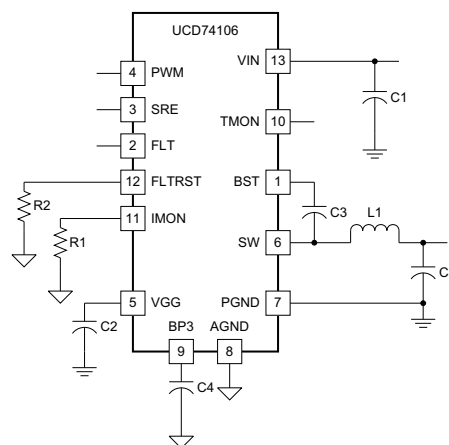

Please be aware that an important notice concerning availability, standard warranty, and use in critical applications of Texas Instruments semiconductor products and disclaimers thereto appears at the end of this data sheet.

DESCRIPTION (CONT.)

On-board current sense amplifiers monitor the current to safeguard the power stage from sudden high current loads. In the event of an over-current fault, the output power stage is turned off and the Fault Flag (FLT) is asserted to alert the controller.

Output current is measured and monitored by a precision integrated current sense element. This method provides an accuracy of $\pm 5\%$. The amplified signal is available for use by the controller on the IMON pin. The IMON pin has a positive offset so that both positive (sourcing) and negative (sinking) current can be sensed.

If the die temperature exceeds 150°C , the temperature sensor initiates a thermal shutdown that halts output switching and sets the FLT flag. Normal operation resumes when the die temperature falls below the thermal hysteresis band and the Fault Flag is re-set by the controller.



This integrated circuit can be damaged by ESD. Texas Instruments recommends that all integrated circuits be handled with appropriate precautions. Failure to observe proper handling and installation procedures can cause damage.

ESD damage can range from subtle performance degradation to complete device failure. Precision integrated circuits may be more susceptible to damage because very small parametric changes could cause the device not to meet its published specifications.

Table 1. ORDERING INFORMATION

OPERATING TEMPERATURE RANGE, T_A	PIN COUNT	ORDERABLE PART NUMBER	SUPPLY	PACKAGE	TOP SIDE MARKING
-40°C to 125°C	13-pin	UCD74106RGMR	Reel of 2500	QFN	UCD74106
		UCD74106RGMT	Reel of 250		

ABSOLUTE MAXIMUM RATINGS⁽¹⁾

over operating free-air temperature range (unless otherwise noted)

	MIN	MAX	UNIT	
Supply voltage, V_{IN}	-0.3	20	V	
Boot voltage, BST	DC	SW + 7		
	AC ⁽²⁾	34		
Gate supply voltage, V_{GG}	-0.3	7		
Switch voltage, SW	DC	VIN + 1		
	AC ⁽²⁾	34		
Analog outputs, TMON, IMON	-0.3	3.6		
Digital I/O's, PWM, SRE, FLT, FLTRST	-0.3	5.5		V
Junction temperature, T_J	-55	150		°C
Storage temperature, T_{stg}	-65	150		
ESD rating, Human Body Model (HBM)		2000	V	
ESD rating, Charged Device Model (CDM)		500		
Lead temperature	Reflow soldering, 10 sec	300	°C	

- (1) Stresses beyond those listed under *absolute maximum ratings* may cause permanent damage to the device. These are stress ratings only and functional operation of the device at these or any other condition beyond those indicated is not implied. Exposure to absolute-maximum-rated conditions for extended periods may affect device reliability. All voltages are with respect to GND. Currents are positive into, negative out of the specified terminal. Consult company packaging information for thermal limitations and considerations of packages.
- (2) AC levels are limited to within 5 ns.

THERMAL INFORMATION

THERMAL METRIC ⁽¹⁾		UCD74106		UNITS
		RGM		
		13 PINS		
θ_{JA}	Junction-to-ambient thermal resistance ⁽²⁾	70.2		°C/W
θ_{JCTop}	Junction-to-case (top) thermal resistance ⁽³⁾	47.3		
θ_{JB}	Junction-to-board thermal resistance ⁽⁴⁾	11.0		
ψ_{JT}	Junction-to-top characterization parameter ⁽⁵⁾	0.9		
ψ_{JB}	Junction-to-board characterization parameter ⁽⁶⁾	11.0		
θ_{JCbott}	Junction-to-case (bottom) thermal resistance ⁽⁷⁾	0.9		

- (1) For more information about traditional and new thermal metrics, see the *IC Package Thermal Metrics* application report, [SPRA953](#).
- (2) The junction-to-ambient thermal resistance under natural convection is obtained in a simulation on a JEDEC-standard, high-K board, as specified in JESD51-7, in an environment described in JESD51-2a.
- (3) The junction-to-case (top) thermal resistance is obtained by simulating a cold plate test on the package top. No specific JEDEC-standard test exists, but a close description can be found in the ANSI SEMI standard G30-88.
- (4) The junction-to-board thermal resistance is obtained by simulating in an environment with a ring cold plate fixture to control the PCB temperature, as described in JESD51-8.
- (5) The junction-to-top characterization parameter, ψ_{JT} , estimates the junction temperature of a device in a real system and is extracted from the simulation data for obtaining θ_{JA} , using a procedure described in JESD51-2a (sections 6 and 7).
- (6) The junction-to-board characterization parameter, ψ_{JB} , estimates the junction temperature of a device in a real system and is extracted from the simulation data for obtaining θ_{JA} , using a procedure described in JESD51-2a (sections 6 and 7).
- (7) The junction-to-case (bottom) thermal resistance is obtained by simulating a cold plate test on the exposed (power) pad. No specific JEDEC standard test exists, but a close description can be found in the ANSI SEMI standard G30-88.

RECOMMENDED OPERATING CONDITIONS

over operating free-air temperature range (unless otherwise noted)

		MIN	TYP	MAX	UNIT
V_{IN}	Power input voltage	Internally generated VGG			V
		Externally supplied VGG			
V_{Gg}	Externally supplied gate drive voltage	4.5	6.2	18	
T_J	Operating junction temperature range	-40		125	

ELECTRICAL CHARACTERISTICS

$V_{IN} = 12\text{ V}$; $1\ \mu\text{F}$ from BP3 to GND, $0.22\ \mu\text{F}$ from BST to SW, $4.7\ \mu\text{F}$ from VGG to PGND, $T_A = T_J = -40^\circ\text{C}$ to 125°C (unless otherwise noted).

PARAMETER		TEST CONDITION	MIN	TYP	MAX	UNITS
Supply						
	Supply current	Outputs not switching, $V_{IN} = 2.2\text{ V}$, $V_{GG} = 5\text{ V}$		4		mA
	Supply current	Outputs not switching, $V_{IN} = 12\text{ V}$,		4		
Gate Drive Under Voltage Lockout						
	VGG UVLO ON	BP3 rising		4.0		V
	VGG UVLO OFF	BP3 falling		3.8		
	VGG UVLO hysteresis			200		mV
VGG Supply Generator						
	VGG	$V_{IN} = 7$ to 14 V	5.2	6.25	6.8	V
	VGG drop out	$V_{IN} = 4.5$ to 7 V , $I_{VGG} < 20\text{ mA}$			200	mV
BP3 Supply Voltage						
	BP3	$I_{DD} = 0$ to 10 mA	3.15	3.3	3.45	V
Input Signal (PWM, SRE)						
V_{IH}	Positive-going input threshold voltage				2.3	V
V_{IL}	Negative-going input threshold voltage		1			
	Tristate condition		1.4		1.9	
t_{HLD_R}	3-state hold-off time	$V_{PWM} = 1.65\text{ V}$			200	ns
	I_{PWM} input current	$V_{PWM} = 5.0\text{ V}$		250		μA
		$V_{PWM} = 3.3\text{ V}$		165		
		$V_{PWM} = 0\text{ V}$		-165		
	I_{SRE} input current	$V_{SRE} = 5.0\text{ V}$		1		
		$V_{SRE} = 3.3\text{ V}$		1		
		$V_{SRE} = 0\text{ V}$		1		

ELECTRICAL CHARACTERISTICS (continued)

$V_{IN} = 12\text{ V}$; $1\ \mu\text{F}$ from BP3 to GND, $0.22\ \mu\text{F}$ from BST to SW, $4.7\ \mu\text{F}$ from VGG to PGND, $T_A = T_J = -40^\circ\text{C}$ to 125°C (unless otherwise noted).

PARAMETER		TEST CONDITION	MIN	TYP	MAX	UNITS
FAULT Flag (FLT)						
FLT	Output high level	$I_{OH} = 500\ \mu\text{A}$	2.7			V
	Output low level	$I_{OL} = 500\ \mu\text{A}$			0.6	
Current Limit						
	Over current threshold	PWM frequency = 1 MHz, $V_{IN} = 12\text{ V}$, $V_{OUT} = 1.2\text{ V}$	6.7	7.5	8.2	A
Current Sense Amplifier						
	Gain ⁽¹⁾	I_{MON}/I_{SW} , $0.3 \leq V(I_{MON}) \leq 1.3\text{ V}$	4.106	4.322	4.538	$\mu\text{A}/\text{A}$
	Zero amp load offset	$0 \leq V(I_{MON}) \leq 3.1\text{ V}$, $R_{IMON} = 22.6\text{ k}\Omega$		22.1		μA
Thermal Sense						
	Thermal shutdown ⁽¹⁾			155		$^\circ\text{C}$
	Thermal shutdown hysteresis ⁽¹⁾			30		
	Temperature sense T ⁽¹⁾	Gain		10		$\text{mV}/^\circ\text{C}$
	Temperature sense T offset	$T_J = 25\ ^\circ\text{C}$, $-100\ \mu\text{A} \leq I_{TMON} \leq 100\ \mu\text{A}$		750		mV
POWER Drive Train						
	Propagation delay from PWM to switch node going high ⁽¹⁾			20		ns
	High-side MOSFET turn on – dead Time ⁽¹⁾		3	5	15	
	Low-side MOSFET turn on – dead time ⁽¹⁾		3	7	15	
	Min PWM pulse width ⁽¹⁾			20 ⁽²⁾		

(1) As designed and characterized, not fully tested in production.

(2) There is no inherent limit on the minimum pulse width. Depending on the board layout, partial enhancement of the high-side FET may be observed for shorter pulse widths.

DEVICE INFORMATION

**RGM Package
(Top View)**

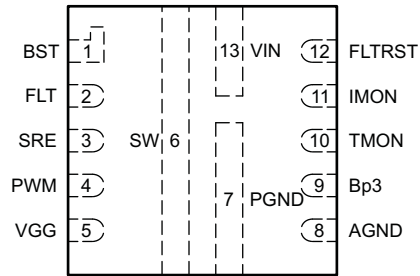

BLOCK DIAGRAM

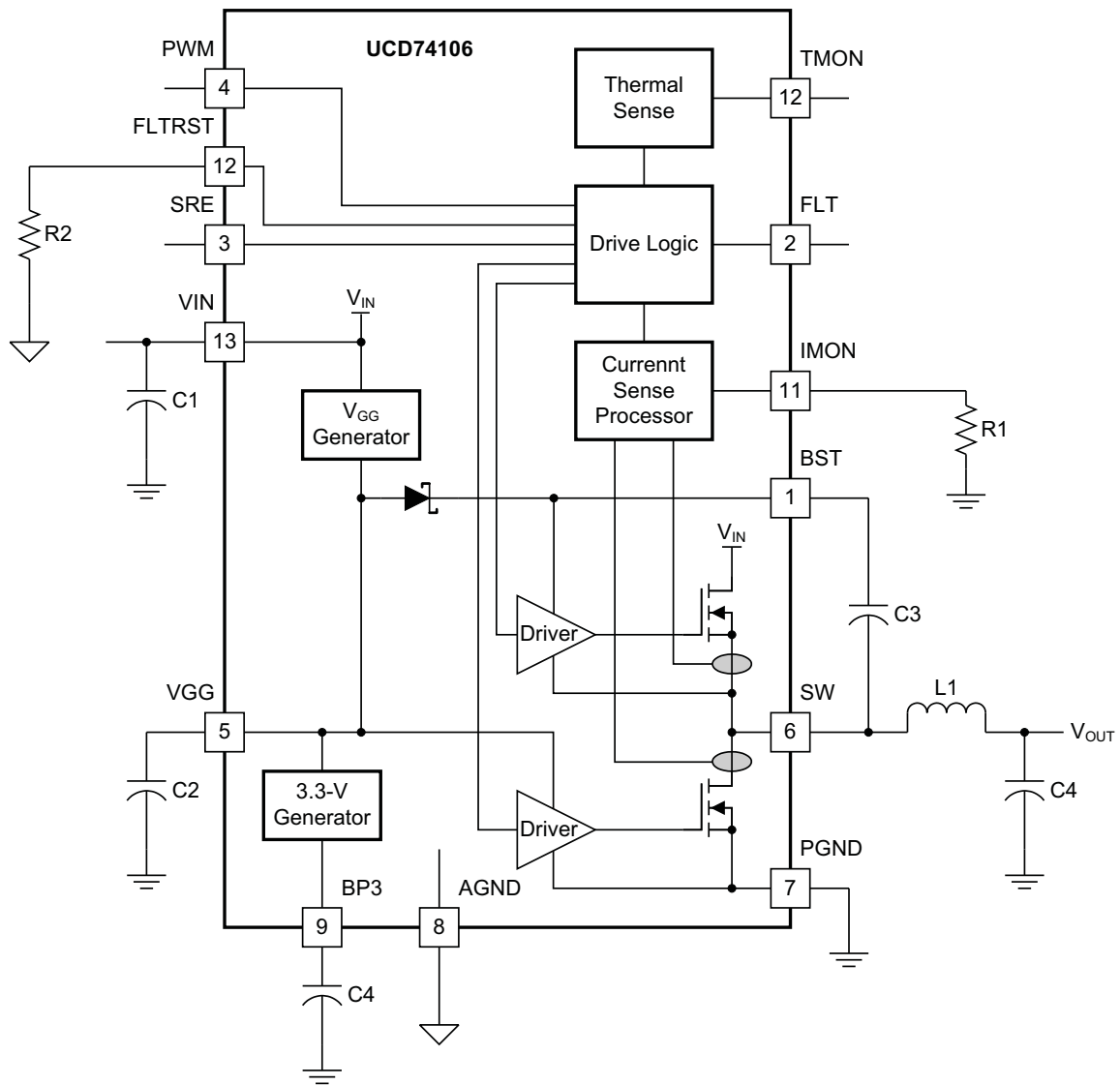

Figure 1. Typical Block Diagram

TERMINAL FUNCTIONS

TERMINAL		I/O	FUNCTION
NAME	NO.		
PWM	4	I	20-k Ω input capable of accepting 3.3-V or 5-V logic level signals up to 2 MHz. A Schmitt trigger input comparator desensitizes this pin from external noise. This pin controls the state of the high-side MOSFET and the low-side MOSFET when SRE is high. When PWM is in HiZ state the output power stage is turned off within 200 ns.
SRE	3	I	Synchronous rectifier enable input. High impedance digital input capable of accepting 3.3-V or 5-V logic level signals used to control the synchronous rectifier switch. An appropriate anti-cross-conduction delay is used during synchronous mode.
BST	1	I	Charge pump capacitor connection. It provides a floating supply for the high-side driver. Connect a 0.22- μ F ceramic capacitor from this pin to SW.
VGG	5	I/O	Gate drive voltage for the power MOSFETs. For $V_{IN} > 4.5$ V, the internal V_{GG} generator can be used. For $V_{IN} < 4.5$ V, this pin should be driven from an external bias supply. In all cases, bypass this pin with a 4.7- μ F (min), 10-V (min) ceramic capacitor to PGND.
BP3	9	O	Output of internal 3.3-V LDO regulator for powering internal logic circuits. Bypass this pin with 1 μ F (min) to AGND . This LDO is supplied by the VGG pin.
IMON	11	O	Current sense monitor output. Provides a current source output that is proportional to the current flowing in the low-side MOSFET. The gain on this pin is equal to 4.32 μ A/A. The IMON pin should be connected to a 22.6-k Ω resistor to AGND to produce a voltage proportional to the power-stage load current. The IMON pin sources 22.1 μ A at no load. This provides a pedestal that permits the reporting of negative (sinking) current.
TMON	10	O	Temperature sense pin. The voltage on this pin is proportional to the die temperature. The gain is 10 mV/ $^{\circ}$ C . At $T_J = 25^{\circ}$ C, the output voltage has an offset of 0.75 V. When the die temperature reaches the thermal shutdown threshold, this pin is pulled to BP3 and power FETs are switched off. Normal operation resumes when the die temperature falls below the thermal hysteresis band.
FLT	2	O	Fault flag. This signal is a 3.3-V digital output which is latched high when the load current exceeds the current limit trip point. When tripped both high side and low side are latched off. See FLT clear protocol as defined by FLTRST. Additionally, if the die temperature exceeds 150 $^{\circ}$ C, V_{IN} and/or V_{GG} is outside of UVLO limits, the output switching will be halted and FLT flag is set. Normal operation resumes after fault clear sequence is complete.
FLTRST	12	I	Fault reset mode.
PGND	7	-	Shared power ground return for the buck power stage
SW	6	-	Switching node of the buck power stage and square wave input to the buck inductor. Electrically this is the connection of the high-side MOSFET source to the low-side MOSFET drain.
VIN	13	-	Input voltage to the buck power stage and driver circuit

TYPICAL CHARACTERISTICS

Typical Efficiency

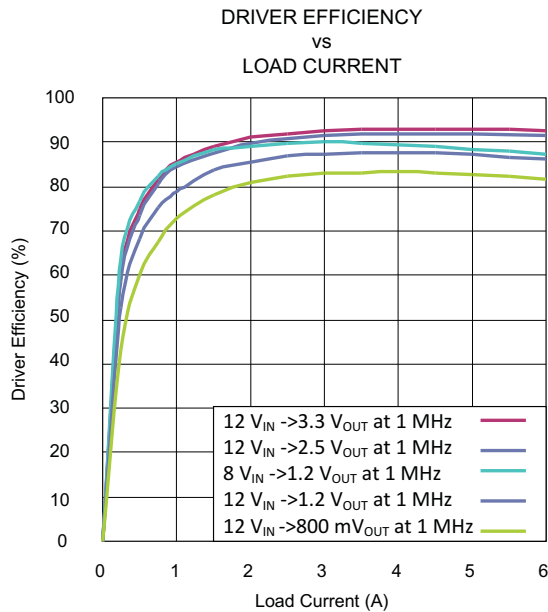

Figure 2.

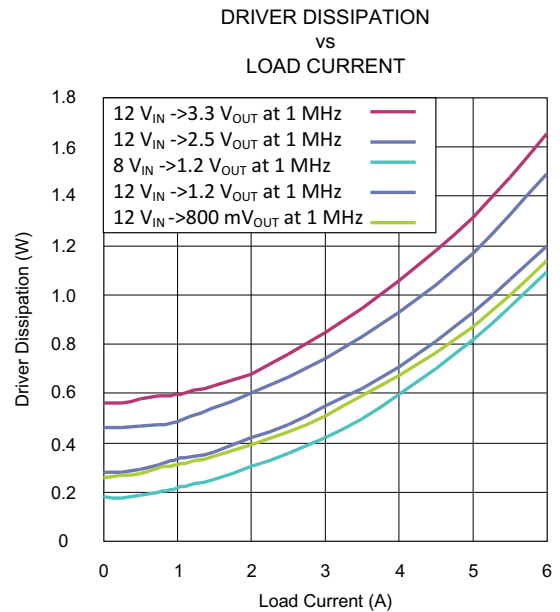

Figure 3.

PWM and SRE Behavior

The PWM and SRE (Synchronous Rectifier Enable) pins control the high-side and low-side drivers, as described in [Table 2](#).

Table 2. PWM and SRE Behavior

	PWM = High	PWM = Low	PWM = HiZ
SRE = High	HS = ON, LS = OFF	HS = OFF, LS = ON	HS = OFF, LS = OFF
SRE = Low	HS = ON, LS = OFF	HS = OFF, LS = OFF	HS = OFF, LS = OFF

Fault Modes

Fault Reset Mode

The Fault Reset Mode can be programmed with the FLTRST pin, as described in [Table 3](#)

Table 3.

Mode	FLTRST	FLT Clear
1	GND	PWM = HiZ
2	BP3	PWM = 0, SRF = 0
3	Open	PWM = 1 pulse

MODE 1

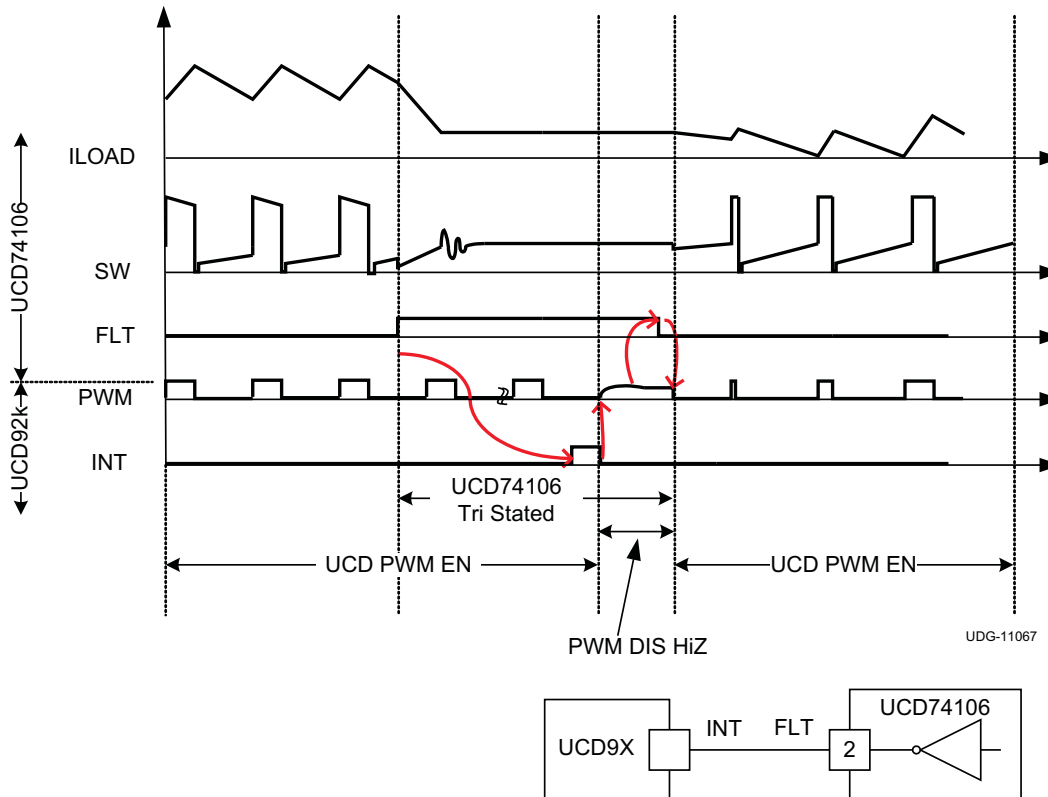

Figure 4. Fault Handshake Protocol, (PWM HiZ)

NOTE

Handshake Sequence:

1. UCD74106 detects fault condition – FLT flag is set
2. FLT flag generates UCD interrupt
3. UCD releases PWM -HiZ state
4. UCD74106 detects (HiZ) as FLT clear; if fault condition is no longer present then flag is cleared
5. If FLT clears UCD responds to the Start command, Else PWM stays in HiZ state

MODE 2

Figure 5. Fault Handshake Protocol, (PWM SRE)

NOTE

Handshake Sequence:

1. UCD74106 detects fault condition – FLT is set
2. FLT flag generates interrupt
3. UCD sets SRE low AND stops PWM
4. UCD74106 reads (SRE and PWM) = low as FLT clear; if fault condition is no longer present then flag is cleared.
5. If FLT clears UCD responds to the Start command, Else (PWM and SRE) = low

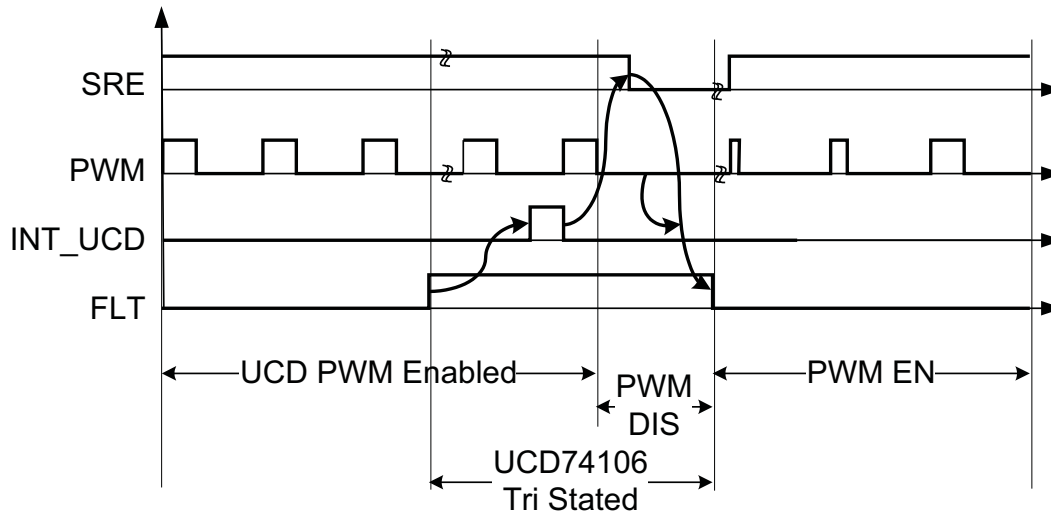
MODE 3

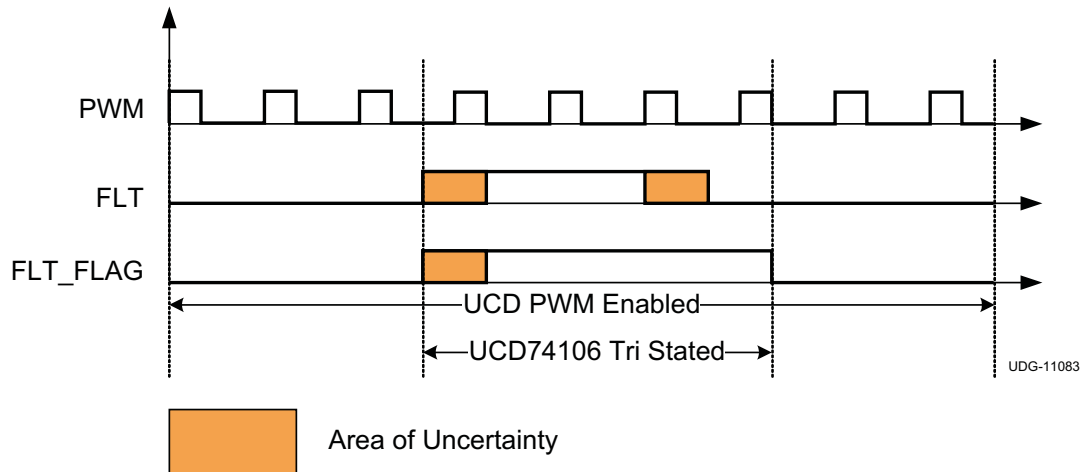

Figure 6. Fault Handshake Protocol, (PWM pulses)

NOTE

No Handshake Re-Set:

1. UCD74106 detects fault condition – FL_FLAG is set
2. No action on UCD side.
3. UCD74106 reads one complete PWM pulse without FLT being present and re-sets FLT_FLAG signal on the falling edge of PWM.
4. Within the area of uncertainty: FLT rising edge to FLT_FLAG rising edge delay is zero (gate delay only).
5. PWM falling edge to FLT_FLAG falling edge delay is zero (gate delay only).

The high-side current limit fault behavior shown in [Figure 7](#).

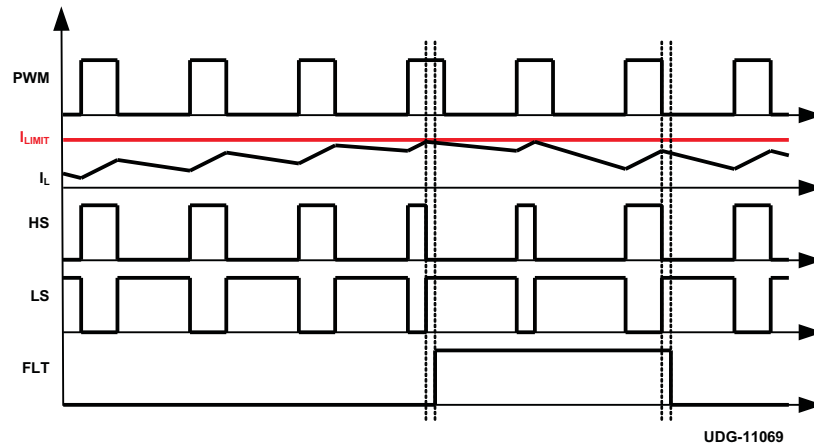

Figure 7.

In general, FLT is always cleared by the first complete PWM pulse (a rising and a falling edge) without a fault present. This is true for all faults including UV and OT. The only exception to this occurs during start up where FLT will self clear once UVLO is disabled, as shown in [Figure 8](#). However, if a subsequent under voltage condition occurs the fault must be cleared by one complete PWM pulse without a fault, as shown in [Figure 7](#).

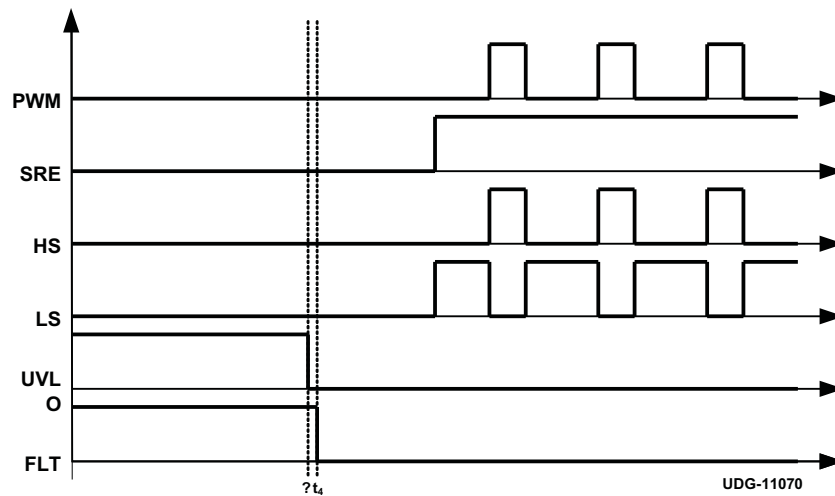

Figure 8.

IMON Behavior

The plot in [Figure 9](#) shows how the voltage on the IMON pin will behave with a 22.6-kΩ resistor. The solid dark line represents the typical behavior and the shaded region represents the tolerance band due too gain.

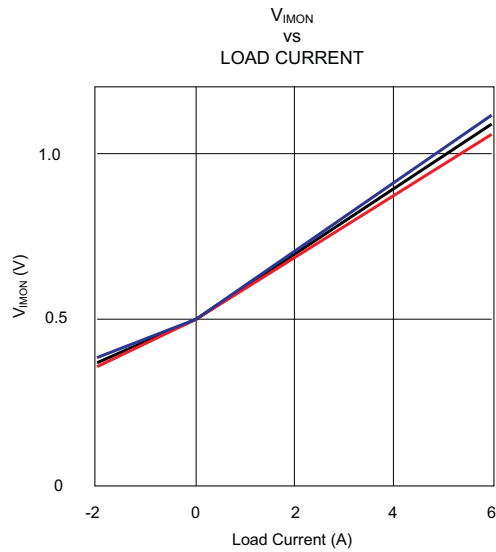

Figure 9.

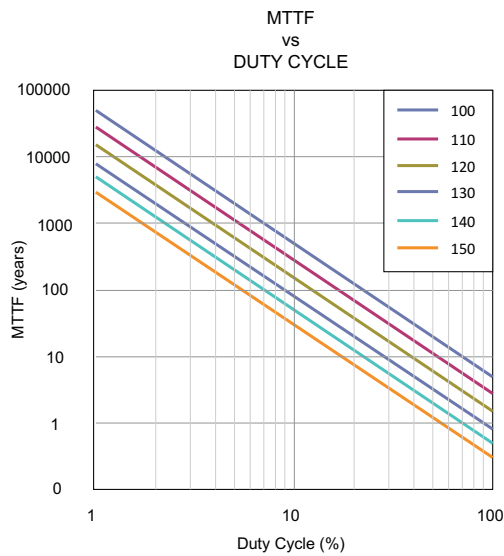

Figure 10.

TMON Behavior

The voltage on this pin is proportional to the die temperature:

$$T_{\text{MON}} = T_{\text{OFFSET}} + T_{\text{GAIN}} \times T_{\text{J}} \quad (1)$$

Table 4. Temperature Sense Definitions

NAME	DESCRIPTION
T_{MON}	Voltage from TMON pin to GND
T_{OFFSET}	Thermal sense T offset
T_{GAIN}	Thermal sense T gain
T_{J}	Device internal junction temperature

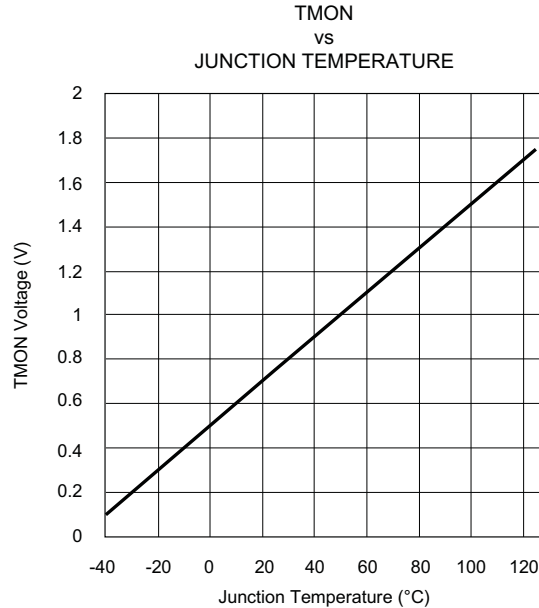

Figure 11.

If the junction temperature exceeds approximately 155°C, the device will enter thermal shutdown. This will assert the FLT pin, both MOSFETs will be turned off and the switch node will become high impedance. When the junction temperature cools by approximately 30°C, the device will exit thermal shutdown and resume switching as directed by the PWM and SRE pins.

APPLICATION INFORMATION

Operating Frequency

Switching frequency is a key place to start the design of any DC/DC converter. This will set performance limits on things such as: maximum efficiency, minimum size, and achievable closed loop bandwidth. A higher switching frequency is, generally, going to yield a smaller design at the expense of a lower efficiency. The size benefit is principally a result of the smaller inductor and capacitor energy storage elements needed to maintain ripple and transient response requirements. The additional losses result from a variety of factors, however, one of the largest contributors is the loss incurred by switching the MOSFETs on and off. The integrated nature of the UCD74106 makes these losses drastically smaller and subsequently enables excellent efficiency from a few hundred kHz up to the low MHz. For a reasonable trade off of size versus efficiency, 750 kHz is a good place to start.

V_{GG}

If $4.5\text{ V} < V_{IN} \leq 6\text{ V}$ then a simple efficiency enhancement can be achieved by connecting V_{GG} directly to V_{IN} . This allows the solution to bypass the drop-out voltage of the internal V_{GG} linear regulator, subsequently improving the enhancement of the MOSFETs. When doing this it is critical to make sure that V_{GG} never exceeds the absolute maximum rating of 7 V.

Inductor selection

There are three main considerations in the selection of an inductor once the switching frequency has been determined. Any real world design is an iterative trade off of each of these factors.

1. The electrical value which in turn is driven by:
 - (a) RMS current
 - (b) The maximum desired output ripple voltage
 - (c) The desired transient response of the converter
2. Losses
 - (a) Copper (PCu)
 - (b) Core (Pfe)
3. Saturation characteristics of the core

Inductance Value

The principle equation used to determine the inductance is:

$$v_L(t) = L \frac{di_L(t)}{dt} \quad (2)$$

During the on time of the converter the inductance can be solved to be:

$$L = \frac{V_{IN} - V_{OUT}}{\Delta I} \frac{D}{f_S} \quad (3)$$

Table 5. Definitions

V_{IN}	Input voltage
V_{OUT}	Output voltage
f_S	Switching frequency
D	Duty cycle (V_{OUT}/V_{IN} for a buck converter)
ΔI	The target peak-to-peak inductor current

In general, it is desirable to make ΔI large to improve transient response and small to reduce output ripple voltage and RMS current. A number of considerations go into this however, $\Delta I = 0.4 I_{OUT}$ results in a small I_{LRMS} without an unnecessary penalty on transient response. It also creates a reasonable ripple current that most practical capacitor banks can handle. Here I_{OUT} is defined as the maximum expected steady state current.

Plugging these assumptions into the above inductance equation results in:

$$L = 5 \frac{V_{IN} - V_{OUT}}{2 \times I_{OUT}} \frac{D}{f_S} \quad (4)$$

For example, plotting this result as a function of V_{IN} and V_{OUT} results in:

- $I_{OUT} = 6.0 \text{ A}$
- $f_S = 1.0 \text{ MHz}$
- $N_{CRIT} = 5$
- $\Delta I / I_{OUT} = 40\%$
- $\Delta I = 2.4 \text{ A}$
- $V_{OUT} \text{ (V)}$

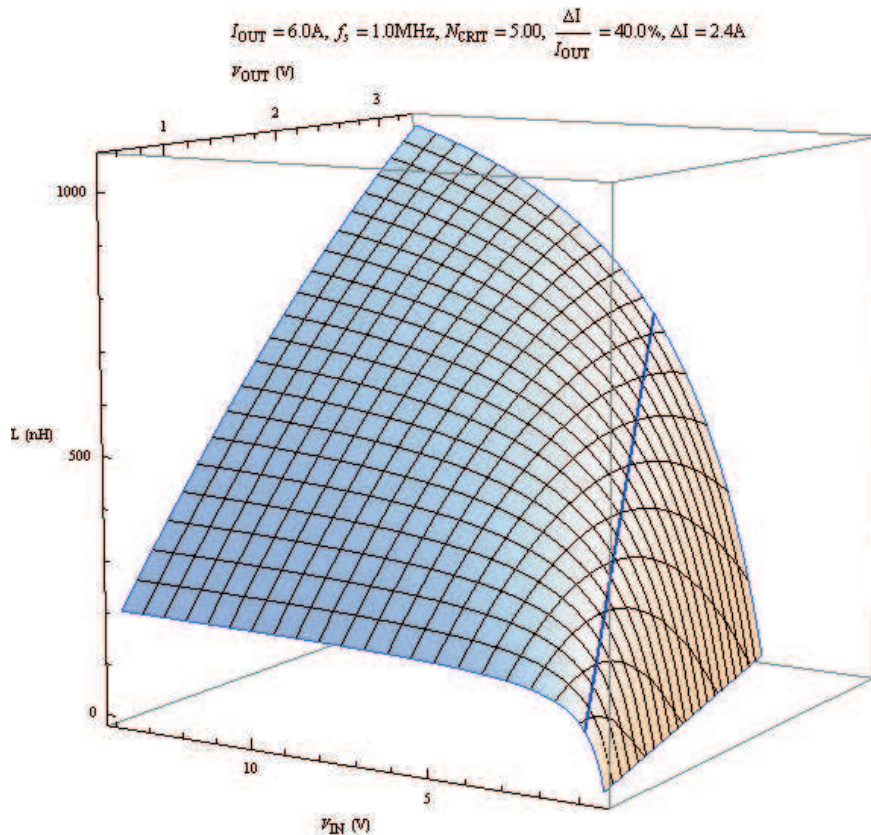

NOTE

The maximum inductance occurs at the maximum V_{IN} and V_{OUT} shown in [Figure 12](#). In general, this inductance value should be used in order to keep the inductor ripple current from becoming too large over the range of supported V_{IN} and V_{OUT} .

Inductor Losses and Saturation

The current rating of an inductor is based on two things, the current necessary to raise the component temperature by 40°C and the current level necessary to reduce the inductance to 80% of its initial value (saturation current). The current rating is the lower of these two numbers. Both of these factors are influenced by the choice of core material. Popular materials currently in use are: ferrite, powdered alloy and powdered iron.

Ferrite is regarded as the highest performance material and as such is the lowest loss and the highest cost. Solid ferrite all by itself will saturate with a relatively small amount of current. This can be addressed by inserting a gap into the core. This, in effect, makes the inductor behave in a linear manner over a wide DC current range. However, once the inductance begins to roll off, these gapped materials exhibit a “sharp” saturation characteristic. In other words the inductance value reduces rapidly with increases in current above the saturation level. This can be dangerous if not carefully considered, in that the current can rise to dangerous levels.

Powdered iron has the advantage of lower cost and a soft saturation characteristic; however, its losses can be very large as switching frequencies increase. This can make it undesirable for a UCD74106 based application where higher switching frequency may be desired. It’s also worth noting that many powdered iron cores exhibit an aging characteristic where the core losses increase over time. This is a wear out mechanism that needs to be considered when using these materials.

The powdered alloy cores bring the soft saturation characteristics of powdered iron with considerable improvements in loss without the wear-out mechanism observed in powdered iron. These benefits come at a cost premium.

In general the following relative figure of merits can be made:

Table 6. Core Material Choices

	FERRITE	POWDERED ALLOY	POWDERED IRON
COST	High	Medium	Low
LOSS	Low	Medium	High
SATURATION	Rapid	Soft	Soft

When selecting an inductor with an appropriate core it’s important to have in mind the following:

- I_{LRMS} , maximum RMS current
- ΔI , maximum peak-to-peak current
- I_{MAX} , maximum peak current

The RMS current can be determined by the following equation:

$$I_{LRMS} = \sqrt{I_{OUT}^2 + \frac{\Delta I^2}{12}} \quad (5)$$

When the 40% ripple constraint is used at maximum load current, this equation simplifies to: $I_{LRMS} \approx I_{OUT}$.

It is widely recognized that the Steinmetz equation (P_{fe}) is a good representation of core losses for sinusoidal stimulation. It is important to recognize that this approximation applies to sinusoidal excitation only. This is a reasonable assumption when working with converters whose duty cycles are near 50%, however, when the duty cycle becomes narrow this estimate may no longer be valid and considerably more loss may result.

$$P_{fe} = k \times f^\alpha \times B_{AC}^\beta \quad (6)$$

The principle drivers in this equation are the material and its respective geometry (k , α , β), the peak AC flux density (B_{AC}) and the excitation frequency (f). The frequency is simply the switching frequency of the converter while the constant k , can be computed based on the effective core volume (V_e) and a specific material constant (k_{fe}).

$$k = k_{fe} \times V_e \quad (7)$$

The AC flux density (B_{AC}) is related to the conventional inductance specifications by the following relationship:

$$B_{AC} = \frac{L}{A_e \times N} \frac{\Delta I}{2} \quad (8)$$

Where L is the inductance, A_e , is the effective cross sectional area that the flux takes through the core and N is the number of turns.

Some inductor manufactures use the inductor ΔI as a figure of merit for this loss, since all of the other terms are a constant for a given component. They may provide a plot of core loss versus ΔI for various frequencies where ΔI can be calculated as:

$$\Delta I = \frac{V_{IN} - V_{OUT}}{L} \frac{D}{f_s} \quad (9)$$

I_{MAX} has a direct impact on the saturation level. A good rule of thumb is to add 15% of head room to the maximum steady state peak value to provide some room for transients.

$$I_{MAX} = 1.15 \times \left(I_{OUT} + \frac{\Delta I}{2} \right) \quad (10)$$

For example for a 6-A design has the following:

Table 7. 6-A Design: Inductor Current Requirements

I_{OUT}	6 A
I_{LRMS}	6 A
ΔI	2.4 A
I_{MAX}	9.6 A

Armed with this data one can now approach the inductor datasheet to select a part with a saturation limit above 9 A and current heating limit above 6 A. Furthermore total losses can be estimated based on the datasheet DCR value ($I_{LRMS}^2 \times DCR$) and the core loss curves for a given frequency and ΔI .

Input Capacitance

Due to the non-zero impedance of the power planes of the input voltage rail, it is necessary to add some local capacitance near the UCD74106 to ensure that the voltage at this node is quiet and stable. The primary things to consider are:

- The radiated fields generated by the di/dt and dv/dt from this node
- RMS currents capability needed in the capacitors
- The AC voltage present and respective susceptibility of any device connected to this node

$$I_{CINRMS} = \sqrt{I_{OUT}^2 \times D \times (1-D) + \frac{\Delta I^2}{12} \times D} \quad (11)$$

As a point of reference if $\Delta I = 0.4 I_{OUT}$ this places the worst case I_{CINRMS} at approximately 3 A. This corresponds to a duty cycle of approximately 50%. Other duty cycles can result in a significantly lower RMS current.

A good input capacitor would be a 22- μ F X5R ceramic capacitor. Equally important as selecting the proper capacitor is placing and routing that capacitor. It is crucial that the decoupling be placed as close as possible to both the power pin (VIN) and ground (PGND). It is important to recognize that each power stage should have its own local decoupling. One 22- μ F capacitor should be placed across each VIN and PGND pair. The proximity of the capacitance to these pins will reduce the radiated fields mentioned above.

Output Capacitance

The goal of the output capacitor bank is to keep the output voltage within regulation limits during steady state and transient conditions.

The total AC RMS current flowing through the capacitor bank can be calculated as:

$$I_{COUTRMS} = \frac{\Delta I}{\sqrt{12}} \quad (12)$$

For a single type of output capacitor the output ripple voltage wave form can be approximated by the following equation:

$$V_{OUT}(t) = I_C(t) \times esr + \frac{1}{C} \int_0^t I_C(\tau) \times d\tau \quad (13)$$

Where:

$$I_C(t) = \begin{cases} \frac{\Delta I \times f_s}{D} \times t - \frac{\Delta I}{2} & t < \frac{D}{f_s} \\ \frac{\Delta I \times f_s}{1-D} \times \left(t - \frac{D}{f_s}\right) + \frac{\Delta I}{2} & \text{otherwise} \end{cases} \quad (14)$$

After substitution and simplification yields:

$$V_{OUT}(t) = \begin{cases} esr \times \left(\frac{\Delta I \times f_s}{D} \times t - \frac{\Delta I}{2} \right) + \frac{1}{C} \times \left(\frac{t \times \Delta I \times (f_s \times t - D)}{2 \times D} - \frac{\Delta I \times (1 - 2 \times D)}{12 \times f_s} \right) & t < \frac{D}{f_s} \\ esr \times \left(\frac{\Delta I \times f_s}{1-D} \times \left(t - \frac{D}{f_s}\right) + \frac{\Delta I}{2} \right) + \frac{1}{C} \times \left(\frac{\Delta I \times (f_s \times t - 1) \times (D - f_s \times t)}{2 \times (1-D) \times f_s} - \frac{\Delta I \times (1 - 2 \times D)}{12 \times f_s} \right) & \text{otherwise} \end{cases} \quad (15)$$

The term in this equation multiplied by the esr gives the ripple voltage component due to esr and the term multiplied by 1/C gives the ripple voltage component due to the change in charge on the capacitor plates. In the case where the esr component dominates the peak-to-peak output voltage can be approximated as:

$$V_{PPesr} \approx \Delta I \times esr \quad (16)$$

When the charge term dominates the peak-to-peak voltage ripple becomes:

$$V_{PPQ} \approx \frac{\Delta I}{8 \times C \times f_s} \quad (17)$$

It's tempting to simply add these two results together for the case where the voltage ripple is significantly influenced by both the capacitance and the esr. However, this will yield an overly pessimistic result, in that it does not account for the phase difference between these terms.

Using the ripple voltage equations and the RMS current equation should give a design that safely meets the steady state output requirements. However, additional capacitance is often needed to meet transient requirements and the specific local decoupling requirements of any device that is being powered off of this voltage. This is not just a function of the capacitor bank but also the dynamics of the control loop. See the UCD9240 Compensation Cookbook for additional details ([TI Literature Number SLUA497](#)).

Decoupling

It is necessary that V_{GG} and BP3 have their own local capacitance as physically close as possible to these pins. The V_{GG} capacitor should be connected as close as possible to the VGG pin and PGND with a 4.7- μ F ceramic capacitor. The BP3 capacitor should be connected as close as possible to BP3 pin and AGND with a 1- μ F ceramic capacitor.

The UCD74106 also supports the ability to operate from input voltages down to 2.2 V. In these cases an additional supply rail must be connected to V_{GG} . Potential external bias supply generators for low VIN operation: TPS63000, TPS61220.

Current Sense

An appropriate resistor must be connected to the current sense output pins to convert the IMON current to a voltage. In the case of the UCD92xx digital controllers, these parts have a full scale current monitor range of 0 V to 2 V. This range can be maximized to make full use of the current monitoring resolution inside the controller.

$$\frac{V_{MON(min)}}{I_{OFFSET} + I_{MIN} \times I_{GAIN}} \leq R_{MON} \leq \frac{V_{MON(max)}}{I_{OFFSET} + I_{MAX} \times I_{GAIN}} \quad (18)$$

Table 8. Current Sense Definitions

NAME	DESCRIPTION
R_{MON}	Resistor from IMON pin to GND
$V_{MON(min)}$	Minimum voltage for IMON (typically, 0.2 V)
$V_{MON(max)}$	Maximum voltage for IMON (typically, 1.8 V)
I_{MIN}	Minimum load current to sense
I_{MAX}	Maximum load current to sense
I_{OFFSET}	Current sense amplifier zero amp load offset
I_{GAIN}	Current sense amplifier gain

The recommended 22.6-k Ω resistor can be used to keep IMON within range for sensing load currents below -2 A to above 6 A.

In some applications it may be necessary to filter the IMON signal. The UCD74106 IMON pin is a current source output, so a capacitor to ground in parallel with the current-to-voltage conversion resistor is all that is required. As a rule of thumb, placing the corner frequency of the filter at 20% of the switching frequency should be sufficient.

For example, if the switching frequency is 500 kHz or higher, the ripple frequency will be easily rejected with a corner frequency of approximately 100 kHz. With a 100-kHz pole point, the filter time constant is 1.6 μ s. A fast current transient should be detected within 4.8 μ s.

$$C_{MON} = \frac{1}{2 \times \pi \times R_{MON} \times 20\% \times f_S} \quad (19)$$

Layout Recommendations

The primary thermal cooling path is from the VIN, GND, and the SW stripes on the bottom of the package. Wide copper traces should connect to these nodes. 1-ounce copper should be the minimum thickness of the top layer; however, 2 ounce is better. Multiple thermal vias should be placed near the GND stripes which connect to a PCB ground plane. There is room to place multiple 10 mil (0.25 mm) diameter vias next to the VIN and GND stripes under the package.

For input bypassing, the 22- μ F input ceramic caps should be connected as close as possible to the VIN and GND stripes. If possible, the input caps should be placed directly under the UCD74106 using multiple 10-mil vias to bring the VIN and GND connections to the back side of the board. Minimizing trace inductance in the bypass path is extremely important to reduce the amplitude of ringing on the switching node.

REVISION HISTORY

Changes from Original (May, 2011) to Revision A	Page
• Changed Wide Input Voltage Range from 14 V to 18 V.	1
• Added updated ABSOLUTE MAXIMUM RATINGS information.	2
• Changed Power input voltage max rating from 16 V to 18 V.	3
• Changed Output high level max rating from 4 mA to 500 μ A.	5
• Changed Output low level max rating from -4 mA to -500 μ A.	5
• Changed GND to AGND.	7
• Changed 4.4 to 4.32.	7
• Changed GND to AGND.	7
• Changed 12 mV/ $^{\circ}$ C to 10 mV/ $^{\circ}$ C.	7
• Changed LS = ON to LS = OFF.	8

PACKAGING INFORMATION

Orderable Device	Status (1)	Package Type	Package Drawing	Pins	Package Qty	Eco Plan (2)	Lead/Ball Finish (6)	MSL Peak Temp (3)	Op Temp (°C)	Device Marking (4/5)	Samples
UCD74106RGMR	ACTIVE	VQFN-HR	RGM	13	3000	Green (RoHS & no Sb/Br)	CU NIPDAU	Level-1-260C-UNLIM	-40 to 125	74106	Samples
UCD74106RGMT	ACTIVE	VQFN-HR	RGM	13	250	Green (RoHS & no Sb/Br)	CU NIPDAU	Level-1-260C-UNLIM	-40 to 125	74106	Samples

(1) The marketing status values are defined as follows:

ACTIVE: Product device recommended for new designs.

LIFEBUY: TI has announced that the device will be discontinued, and a lifetime-buy period is in effect.

NRND: Not recommended for new designs. Device is in production to support existing customers, but TI does not recommend using this part in a new design.

PREVIEW: Device has been announced but is not in production. Samples may or may not be available.

OBSELETE: TI has discontinued the production of the device.

(2) Eco Plan - The planned eco-friendly classification: Pb-Free (RoHS), Pb-Free (RoHS Exempt), or Green (RoHS & no Sb/Br) - please check <http://www.ti.com/productcontent> for the latest availability information and additional product content details.

TBD: The Pb-Free/Green conversion plan has not been defined.

Pb-Free (RoHS): TI's terms "Lead-Free" or "Pb-Free" mean semiconductor products that are compatible with the current RoHS requirements for all 6 substances, including the requirement that lead not exceed 0.1% by weight in homogeneous materials. Where designed to be soldered at high temperatures, TI Pb-Free products are suitable for use in specified lead-free processes.

Pb-Free (RoHS Exempt): This component has a RoHS exemption for either 1) lead-based flip-chip solder bumps used between the die and package, or 2) lead-based die adhesive used between the die and leadframe. The component is otherwise considered Pb-Free (RoHS compatible) as defined above.

Green (RoHS & no Sb/Br): TI defines "Green" to mean Pb-Free (RoHS compatible), and free of Bromine (Br) and Antimony (Sb) based flame retardants (Br or Sb do not exceed 0.1% by weight in homogeneous material)

(3) MSL, Peak Temp. - The Moisture Sensitivity Level rating according to the JEDEC industry standard classifications, and peak solder temperature.

(4) There may be additional marking, which relates to the logo, the lot trace code information, or the environmental category on the device.

(5) Multiple Device Markings will be inside parentheses. Only one Device Marking contained in parentheses and separated by a "~" will appear on a device. If a line is indented then it is a continuation of the previous line and the two combined represent the entire Device Marking for that device.

(6) Lead/Ball Finish - Orderable Devices may have multiple material finish options. Finish options are separated by a vertical ruled line. Lead/Ball Finish values may wrap to two lines if the finish value exceeds the maximum column width.

Important Information and Disclaimer: The information provided on this page represents TI's knowledge and belief as of the date that it is provided. TI bases its knowledge and belief on information provided by third parties, and makes no representation or warranty as to the accuracy of such information. Efforts are underway to better integrate information from third parties. TI has taken and continues to take reasonable steps to provide representative and accurate information but may not have conducted destructive testing or chemical analysis on incoming materials and chemicals. TI and TI suppliers consider certain information to be proprietary, and thus CAS numbers and other limited information may not be available for release.

In no event shall TI's liability arising out of such information exceed the total purchase price of the TI part(s) at issue in this document sold by TI to Customer on an annual basis.

TAPE AND REEL INFORMATION



QUADRANT ASSIGNMENTS FOR PIN 1 ORIENTATION IN TAPE



*All dimensions are nominal

Device	Package Type	Package Drawing	Pins	SPQ	Reel Diameter (mm)	Reel Width W1 (mm)	A0 (mm)	B0 (mm)	K0 (mm)	P1 (mm)	W (mm)	Pin1 Quadrant
UCD74106RGMR	VQFN-HR	RGM	13	3000	330.0	12.4	3.3	3.3	1.1	8.0	12.0	Q2
UCD74106RGMT	VQFN-HR	RGM	13	250	180.0	12.4	3.3	3.3	1.1	8.0	12.0	Q2

TAPE AND REEL BOX DIMENSIONS



*All dimensions are nominal

Device	Package Type	Package Drawing	Pins	SPQ	Length (mm)	Width (mm)	Height (mm)
UCD74106RGMR	VQFN-HR	RGM	13	3000	367.0	367.0	35.0
UCD74106RGMT	VQFN-HR	RGM	13	250	210.0	185.0	35.0

MECHANICAL DATA

RGM (S-PVQFN-N13)

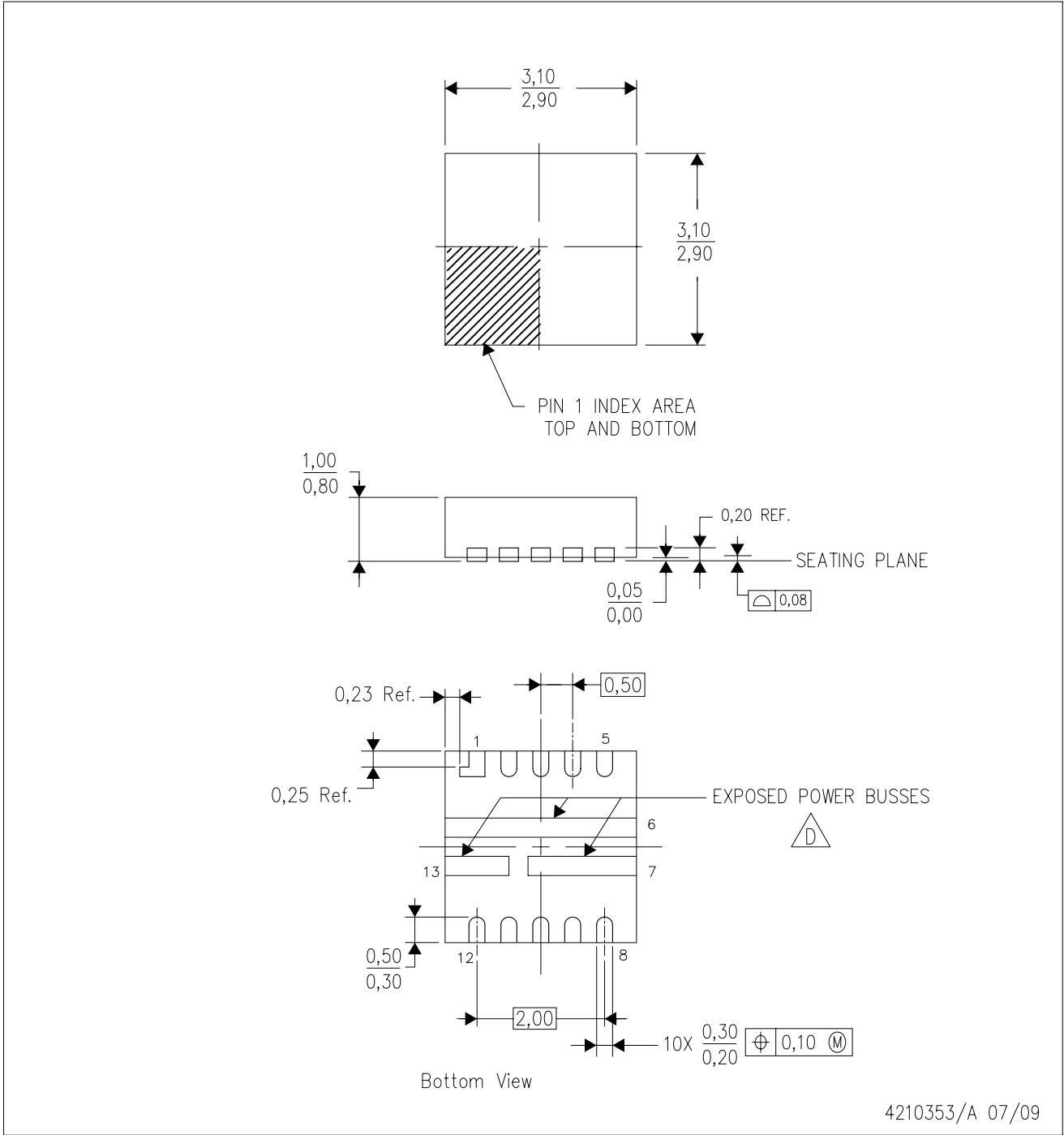
PLASTIC QUAD FLATPACK NO-LEAD



- NOTES:
- A. All linear dimensions are in millimeters. Dimensioning and tolerancing per ASME Y14.5M-1994.
 - B. This drawing is subject to change without notice.
 - C. Quad Flatpack, No-leads (QFN) package configuration.
 -  See the Product Data Sheet for details regarding the exposed power buss dimensions.
 - E. RoHS exempt flip chip application. Internal solder joints may contain Pb.
 - F. Exposed terminals are Pb-free

THERMAL INFORMATION

This package incorporates an exposed and partitioned thermal pad that functions electrically as distinct power busses. The power busses must be soldered directly to the printed circuit board (PCB). After soldering, the PCB electrically connects the power busses. In addition, the PCB can be used as a heatsink that can be enhanced with the use of thermal vias.

For information on the Quad Flatpack No-Lead (QFN) package and its advantages, refer to Application Report, QFN/SON PCB Attachment, Texas Instruments Literature No. SLUA271. This document is available at www.ti.com.

The exposed power buss dimensions for this package are shown in the following illustration.

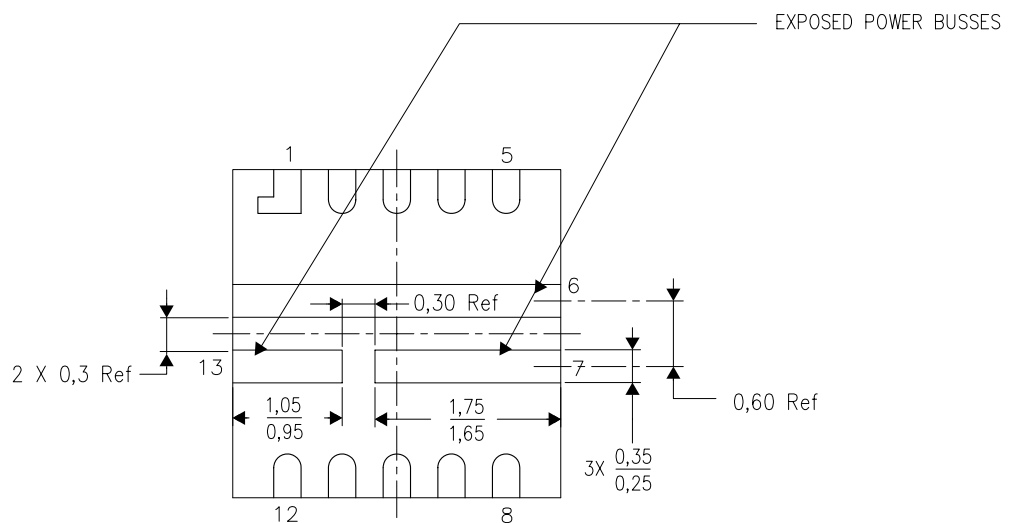

Bottom View

NOTE: All linear dimensions are in millimeters

Exposed Power Buss Dimensions

RGM (R-PVQFN-N13)

PLASTIC QUAD FLATPACK NO-LEAD

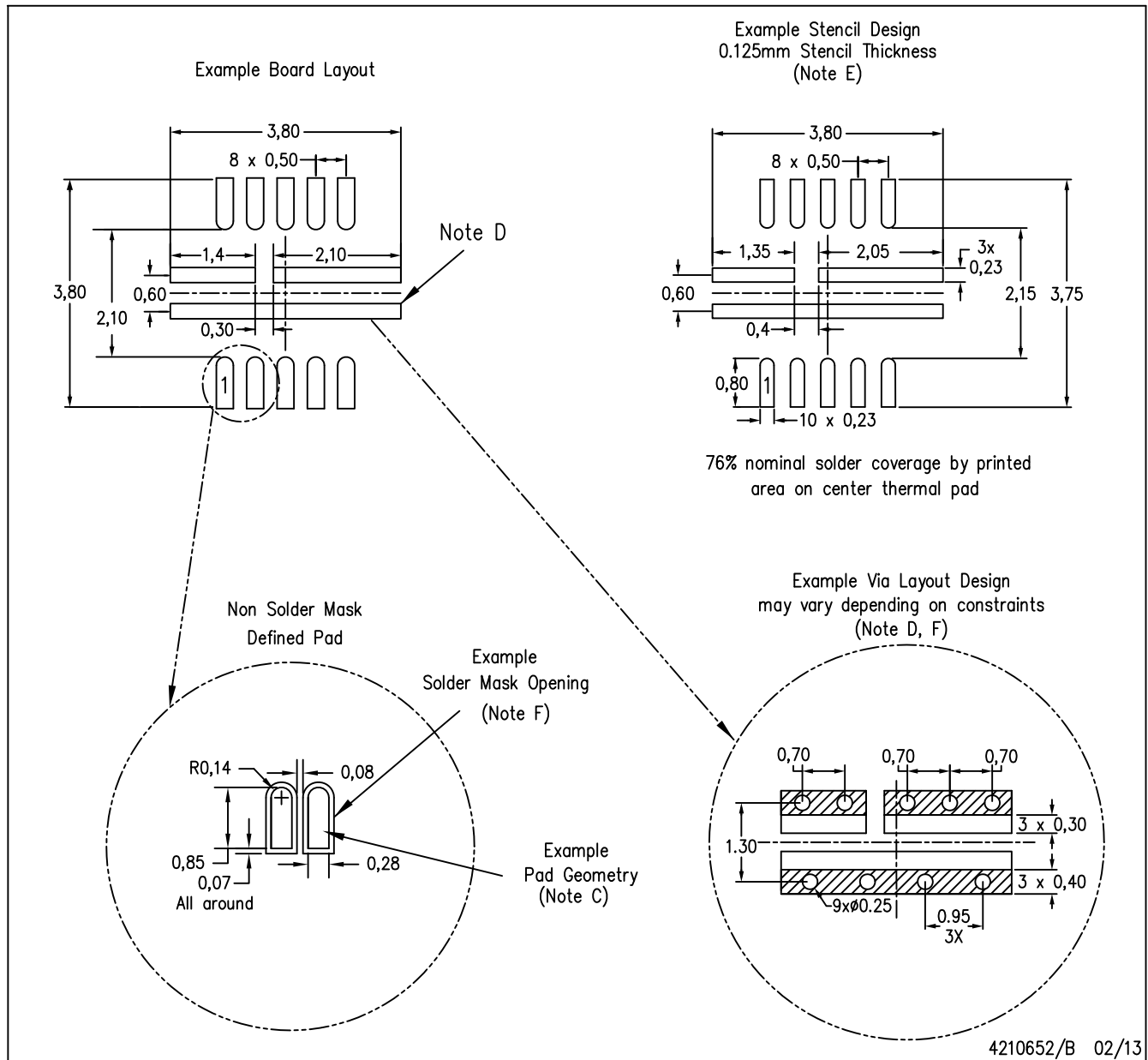

4210652/B 02/13

- NOTES:
- All linear dimensions are in millimeters.
 - This drawing is subject to change without notice.
 - Publication IPC-7351 is recommended for alternate designs.
 - This package is designed to be soldered to a thermal pad on the board. Refer to Application Note, Quad Flat-Pack Packages, Texas Instruments Literature No. SLUA271, and also the Product Data Sheets for specific thermal information, via requirements, and recommended board layout. These documents are available at www.ti.com <<http://www.ti.com>>.
 - Laser cutting apertures with trapezoidal walls and also rounding corners will offer better paste release. Customers should contact their board assembly site for stencil design recommendations. Refer to IPC 7525 for stencil design considerations.
 - Customers should contact their board fabrication site for minimum solder mask web tolerances between signal pads.

IMPORTANT NOTICE

Texas Instruments Incorporated (TI) reserves the right to make corrections, enhancements, improvements and other changes to its semiconductor products and services per JESD46, latest issue, and to discontinue any product or service per JESD48, latest issue. Buyers should obtain the latest relevant information before placing orders and should verify that such information is current and complete.

TI's published terms of sale for semiconductor products (<http://www.ti.com/sc/docs/stdterms.htm>) apply to the sale of packaged integrated circuit products that TI has qualified and released to market. Additional terms may apply to the use or sale of other types of TI products and services.

Reproduction of significant portions of TI information in TI data sheets is permissible only if reproduction is without alteration and is accompanied by all associated warranties, conditions, limitations, and notices. TI is not responsible or liable for such reproduced documentation. Information of third parties may be subject to additional restrictions. Resale of TI products or services with statements different from or beyond the parameters stated by TI for that product or service voids all express and any implied warranties for the associated TI product or service and is an unfair and deceptive business practice. TI is not responsible or liable for any such statements.

Buyers and others who are developing systems that incorporate TI products (collectively, "Designers") understand and agree that Designers remain responsible for using their independent analysis, evaluation and judgment in designing their applications and that Designers have full and exclusive responsibility to assure the safety of Designers' applications and compliance of their applications (and of all TI products used in or for Designers' applications) with all applicable regulations, laws and other applicable requirements. Designer represents that, with respect to their applications, Designer has all the necessary expertise to create and implement safeguards that (1) anticipate dangerous consequences of failures, (2) monitor failures and their consequences, and (3) lessen the likelihood of failures that might cause harm and take appropriate actions. Designer agrees that prior to using or distributing any applications that include TI products, Designer will thoroughly test such applications and the functionality of such TI products as used in such applications.

TI's provision of technical, application or other design advice, quality characterization, reliability data or other services or information, including, but not limited to, reference designs and materials relating to evaluation modules, (collectively, "TI Resources") are intended to assist designers who are developing applications that incorporate TI products; by downloading, accessing or using TI Resources in any way, Designer (individually or, if Designer is acting on behalf of a company, Designer's company) agrees to use any particular TI Resource solely for this purpose and subject to the terms of this Notice.

TI's provision of TI Resources does not expand or otherwise alter TI's applicable published warranties or warranty disclaimers for TI products, and no additional obligations or liabilities arise from TI providing such TI Resources. TI reserves the right to make corrections, enhancements, improvements and other changes to its TI Resources. TI has not conducted any testing other than that specifically described in the published documentation for a particular TI Resource.

Designer is authorized to use, copy and modify any individual TI Resource only in connection with the development of applications that include the TI product(s) identified in such TI Resource. NO OTHER LICENSE, EXPRESS OR IMPLIED, BY ESTOPPEL OR OTHERWISE TO ANY OTHER TI INTELLECTUAL PROPERTY RIGHT, AND NO LICENSE TO ANY TECHNOLOGY OR INTELLECTUAL PROPERTY RIGHT OF TI OR ANY THIRD PARTY IS GRANTED HEREIN, including but not limited to any patent right, copyright, mask work right, or other intellectual property right relating to any combination, machine, or process in which TI products or services are used. Information regarding or referencing third-party products or services does not constitute a license to use such products or services, or a warranty or endorsement thereof. Use of TI Resources may require a license from a third party under the patents or other intellectual property of the third party, or a license from TI under the patents or other intellectual property of TI.

TI RESOURCES ARE PROVIDED "AS IS" AND WITH ALL FAULTS. TI DISCLAIMS ALL OTHER WARRANTIES OR REPRESENTATIONS, EXPRESS OR IMPLIED, REGARDING RESOURCES OR USE THEREOF, INCLUDING BUT NOT LIMITED TO ACCURACY OR COMPLETENESS, TITLE, ANY EPIDEMIC FAILURE WARRANTY AND ANY IMPLIED WARRANTIES OF MERCHANTABILITY, FITNESS FOR A PARTICULAR PURPOSE, AND NON-INFRINGEMENT OF ANY THIRD PARTY INTELLECTUAL PROPERTY RIGHTS. TI SHALL NOT BE LIABLE FOR AND SHALL NOT DEFEND OR INDEMNIFY DESIGNER AGAINST ANY CLAIM, INCLUDING BUT NOT LIMITED TO ANY INFRINGEMENT CLAIM THAT RELATES TO OR IS BASED ON ANY COMBINATION OF PRODUCTS EVEN IF DESCRIBED IN TI RESOURCES OR OTHERWISE. IN NO EVENT SHALL TI BE LIABLE FOR ANY ACTUAL, DIRECT, SPECIAL, COLLATERAL, INDIRECT, PUNITIVE, INCIDENTAL, CONSEQUENTIAL OR EXEMPLARY DAMAGES IN CONNECTION WITH OR ARISING OUT OF TI RESOURCES OR USE THEREOF, AND REGARDLESS OF WHETHER TI HAS BEEN ADVISED OF THE POSSIBILITY OF SUCH DAMAGES.

Unless TI has explicitly designated an individual product as meeting the requirements of a particular industry standard (e.g., ISO/TS 16949 and ISO 26262), TI is not responsible for any failure to meet such industry standard requirements.

Where TI specifically promotes products as facilitating functional safety or as compliant with industry functional safety standards, such products are intended to help enable customers to design and create their own applications that meet applicable functional safety standards and requirements. Using products in an application does not by itself establish any safety features in the application. Designers must ensure compliance with safety-related requirements and standards applicable to their applications. Designer may not use any TI products in life-critical medical equipment unless authorized officers of the parties have executed a special contract specifically governing such use. Life-critical medical equipment is medical equipment where failure of such equipment would cause serious bodily injury or death (e.g., life support, pacemakers, defibrillators, heart pumps, neurostimulators, and implantables). Such equipment includes, without limitation, all medical devices identified by the U.S. Food and Drug Administration as Class III devices and equivalent classifications outside the U.S.

TI may expressly designate certain products as completing a particular qualification (e.g., Q100, Military Grade, or Enhanced Product). Designers agree that it has the necessary expertise to select the product with the appropriate qualification designation for their applications and that proper product selection is at Designers' own risk. Designers are solely responsible for compliance with all legal and regulatory requirements in connection with such selection.

Designer will fully indemnify TI and its representatives against any damages, costs, losses, and/or liabilities arising out of Designer's non-compliance with the terms and provisions of this Notice.

Looking for pricing, stock, or lifecycle information?

Click below to explore more details on WIN SOURCE:

 [View UCD74106RGMR](#) on WIN SOURCE

 [Texas Instruments](#) Information

Optimize Your Supply Chain with WIN SOURCE Solutions

-  Global Sourcing Solution
-  Obsolete Management
-  Cost Control Management
-  Shortage Management
-  Alternative Solution
-  Excess Inventory Management