



**THE DATASHEET OF  
TPS40192DRCTG4**



# TPS4019x 4.5-V to 18-V Input, Voltage-Mode, Synchronous Buck Controller With Power Good

## 1 Features

- Input Operating Voltage Range: 4.5 V to 18 V
- Up to 20-A Output Currents
- Supports Pre-Biased Outputs
- 0.5%, 591-mV Reference
- Switching Frequency
  - TPS40192: 600 kHz
  - TPS40193: 300 kHz
- Three Selectable Thermally Compensated Short-Circuit Protection Levels
- Hiccup Restart from Faults
- Internal 5-V Regulator
- High-Side and Low-Side MOSFET ON-resistance ( $R_{DS(on)}$ ) Current Sensing
- 10-Pin 3 mm × 3 mm SON Package
- Internal 4-ms Soft-Start Time
- Thermal Shutdown Protection at 145°C

## 2 Applications

- Cable Modem CPE
- Digital Set Top Box
- Graphics/Audio Cards
- Entry Level and Mid-Range Servers

## 3 Description

TPS40192 and TPS40193 are cost-optimized synchronous buck controllers that operate from 4.5 V to 18 V input. These controllers implement a voltage-mode control architecture with the switching frequency fixed at either 600 kHz (TPS40192) or 300 kHz (TPS40193). The higher switching frequency facilitates the use of smaller inductor and output capacitors, thereby providing a compact power-supply solution. An adaptive anti-cross conduction scheme is used to prevent shoot through current in the power FETs.

Short circuit detection is done by sensing the voltage drop across the low-side MOSFET when it is on and comparing it with a user selected threshold of 100 mV, 200 mV or 280 mV. The threshold is set with a single external resistor connected from COMP to GND. This resistor is sensed at startup and the selected threshold is latched. Pulse-by-pulse limiting (to prevent current runaway) is provided by sensing the voltage across the high-side MOSFET when it is on and terminating the cycle when the voltage drop rises above a fixed threshold of 550 mV. When the controller senses an output short circuit, both MOSFETs are turned off and a timeout period is observed before attempting to restart. This behavior provides limited power dissipation in the event of a sustained fault.

### Device Information<sup>(1)</sup>

PART NUMBER	PACKAGE	BODY SIZE (NOM)
TPS40192	VSON (10)	3.00 mm × 3.00 mm

(1) For all available packages, see the orderable addendum at the end of the data sheet.

### Simplified Application Diagram

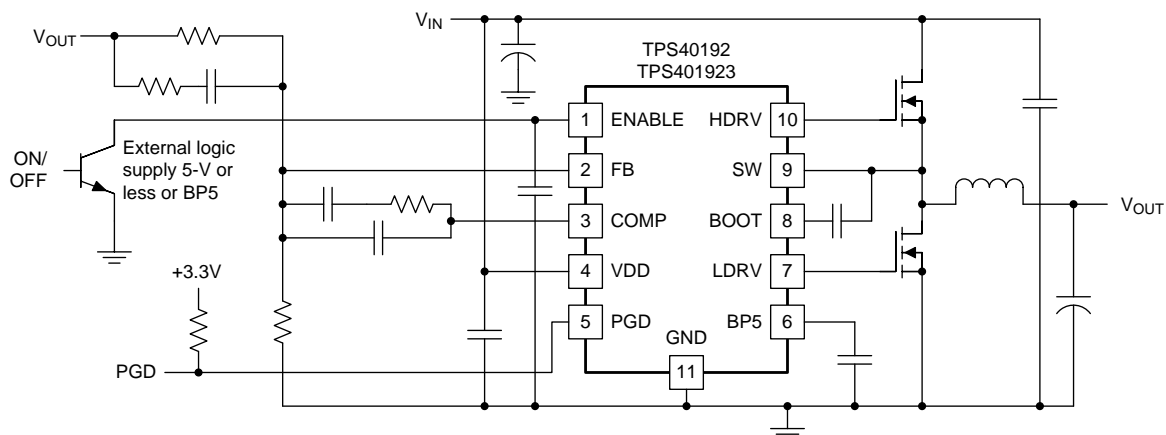

Copyright © 2016, Texas Instruments Incorporated



## Table of Contents

<b>1 Features</b> .....	<b>1</b>	<b>8 Application and Implementation</b> .....	<b>15</b>
<b>2 Applications</b> .....	<b>1</b>	8.1 Application Information.....	15
<b>3 Description</b> .....	<b>1</b>	8.2 Typical Application .....	15
<b>4 Revision History</b> .....	<b>2</b>	<b>9 Power Supply Recommendations</b> .....	<b>23</b>
<b>5 Pin Configuration and Functions</b> .....	<b>3</b>	<b>10 Layout</b> .....	<b>24</b>
<b>6 Specifications</b> .....	<b>4</b>	10.1 Layout Guidelines .....	24
6.1 Absolute Maximum Ratings .....	4	10.2 Layout Examples.....	24
6.2 ESD Ratings.....	4	<b>11 Device and Documentation Support</b> .....	<b>26</b>
6.3 Recommended Operating Conditions.....	4	11.1 Device Support.....	26
6.4 Thermal Information .....	4	11.2 Documentation Support .....	27
6.5 Electrical Characteristics.....	5	11.3 Related Links .....	27
6.6 Dissipation Ratings .....	6	11.4 Receiving Notification of Documentation Updates	27
6.7 Typical Characteristics.....	7	11.5 Community Resources.....	27
<b>7 Detailed Description</b> .....	<b>9</b>	11.6 Trademarks .....	27
7.1 Overview .....	9	11.7 Electrostatic Discharge Caution.....	27
7.2 Functional Block Diagram .....	9	11.8 Glossary .....	27
7.3 Feature Description.....	9	<b>12 Mechanical, Packaging, and Orderable</b>	
7.4 Device Functional Modes.....	14	<b>Information</b> .....	<b>28</b>

## 4 Revision History

NOTE: Page numbers for previous revisions may differ from page numbers in the current version.

<b>Changes from Revision G (January 2019) to Revision H</b>	<b>Page</b>
• Editorial changes only, no technical revisions.....	1

---

<b>Changes from Revision F (November 2016) to Revision G</b>	<b>Page</b>
• Deleted last sentence in <a href="#">Enable Functionality</a> .....	10
• Deleted TPS40190 from <a href="#">Table 6</a> .....	26

---

<b>Changes from Revision E (May 2013) to Revision F</b>	<b>Page</b>
• Added <i>Pin Configuration and Functions</i> section, <i>ESD Rating</i> table, <i>Feature Description</i> section, <i>Device Functional Modes</i> , <i>Application and Implementation</i> section, <i>Power Supply Recommendations</i> section, <i>Layout</i> section, <i>Device and Documentation Support</i> section, and <i>Mechanical, Packaging, and Orderable Information</i> section .....	1

---

<b>Changes from Revision D (July 2012) to Revision E</b>	<b>Page</b>
• Added clarity to <a href="#">Figure 15</a> .....	15
• Added note regarding high-resistance resistor.....	19

---

<b>Changes from Revision C (August 2010) to Revision D</b>	<b>Page</b>
• Added text to the last paragraph in the <a href="#">Enable Functionality</a> section. ....	10

---

<b>Changes from Revision B (September 2007) to Revision C</b>	<b>Page</b>
• Changed corrected label for pin 8 .....	3
• Changed corrected waveform .....	11

## 5 Pin Configuration and Functions



### Pin Functions

PIN		I/O	DESCRIPTION
NAME	NO.		
BOOT	8	I	Gate drive voltage for the high-side N-channel MOSFET. A 100-nF typical capacitor must be connected between this pin and SW.
BP5	6	O	Output bypass for the internal regulator. Connect a capacitor with a value of at least 1- $\mu$ F from this pin to GND. Larger capacitors (up to 4.7 $\mu$ F) can improve noise performance when using a low-side MOSFET with a gate charge of 25 nC or greater. Low power, low noise loads may be connected here if desired. The sum of the external load and the gate drive requirements must not exceed 50 mA. This regulator is turned off when ENABLE is pulled low.
COMP	3	O	Output of the error amplifier.
ENABLE	1	I	Logic level input which starts or stops the controller from an external user command. A high-level turns the controller on. A weak internal pullup holds this pin high so that the pin may be left floating if this function is not used.
FB	2	I	Inverting input to the error amplifier. In normal operation the voltage on this pin is equal to the internal reference voltage (591 mV typical)
HDRV	10	O	Bootstrapped output for driving the gate of the high-side N-channel FET.
LDRV	7	O	Output to the rectifier MOSFET gate
PGD	5	O	Open drain power good output
SW	9	I	Sense line for the adaptive anti-cross conduction circuitry. Serves as common connection for the flying high-side MOSFET driver
VDD	4	I	Power input to the controller
Thermal pad		G	Common reference for the device. Connect to the system GND.

## 6 Specifications

### 6.1 Absolute Maximum Ratings

over operating free-air temperature range unless otherwise noted<sup>(1)</sup>

		MIN	MAX	UNIT
Input voltage	VDD, ENABLE	-0.3	20	V
	SW	-5	25	
	BOOT, HDRV	-0.3	30	
	BOOT-SW, HDRV-SW (differential from BOOT or HDRV to SW)	-0.3	6	
	COMP, FB, BP5, LDRV, PGD	-0.3	6	
Operating junction temperature, T <sub>J</sub>		-40	150	°C
Storage temperature, T <sub>stg</sub>		-55	150	

(1) Stresses beyond those listed under "absolute maximum ratings" may cause permanent damage to the device. These are stress ratings only, and functional operation of the device at these or any other conditions beyond those indicated under "recommended operating conditions" is not implied. Exposure to absolute-maximum-rated conditions for extended periods may affect device reliability.

### 6.2 ESD Ratings

			VALUE	UNIT
V <sub>(ESD)</sub>	Electrostatic discharge	Human-body model (HBM), per ANSI/ESDA/JEDEC JS-001 <sup>(1)</sup>	±2500	V
		Charged-device model (CDM), per JEDEC specification JESD22-C101 <sup>(2)</sup>	±1500	

(1) JEDEC document JEP155 states that 500-V HBM allows safe manufacturing with a standard ESD control process.

(2) JEDEC document JEP157 states that 250-V CDM allows safe manufacturing with a standard ESD control process.

### 6.3 Recommended Operating Conditions

		MIN	MAX	UNIT
V <sub>VDD</sub>	Input voltage	4.5	18	V
T <sub>J</sub>	Operating Junction temperature	-40	125	°C

### 6.4 Thermal Information

THERMAL METRIC <sup>(1)</sup>		TPS40192	UNIT
		DRC (VSON)	
		10 PINS	
R <sub>θJA</sub>	Junction-to-ambient thermal resistance	46.4	°C/W
R <sub>θJC(top)</sub>	Junction-to-case (top) thermal resistance	51.4	°C/W
R <sub>θJB</sub>	Junction-to-board thermal resistance	21.8	°C/W
ψ <sub>JT</sub>	Junction-to-top characterization parameter	0.9	°C/W
ψ <sub>JB</sub>	Junction-to-board characterization parameter	22.0	°C/W
R <sub>θJC(bot)</sub>	Junction-to-case (bottom) thermal resistance	6.6	°C/W

(1) For more information about traditional and new thermal metrics, see the *Semiconductor and IC Package Thermal Metrics* application report, [SPRA953](#).

## 6.5 Electrical Characteristics

$T_J = -40^{\circ}\text{C}$  to  $85^{\circ}\text{C}$ ,  $V_{VDD} = 12 V_{dc}$ , all parameters at zero power dissipation (unless otherwise noted)

PARAMETER		TEST CONDITIONS	MIN	TYP	MAX	UNIT
<b>REFERENCE</b>						
$V_{FB}$	Feedback voltage range	$0^{\circ}\text{C} \leq T_J \leq 85^{\circ}\text{C}$	588	591	594	mV
		$-40^{\circ}\text{C} \leq T_J \leq 85^{\circ}\text{C}$	585	591	594	
<b>INPUT SUPPLY</b>						
$V_{VDD}$	Input voltage range		4.5		18	V
$I_{VDD}$	Operating current	$V_{ENABLE} = 3\text{ V}$		2.5	4	mA
		$V_{ENABLE} = 0.6\text{ V}$		45	70	$\mu\text{A}$
<b>ON-BOARD REGULATOR</b>						
$V_{5VBP}$	Output voltage	$V_{VDD} > 6\text{ V}$ , $I_{5VBP} \leq 10\text{ mA}$	5.1	5.3	5.5	V
$V_{DO}$	Regulator dropout voltage	$V_{VDD} - V_{BP5}$ , $V_{VDD} = 5\text{ V}$ , $I_{BP5} \leq 25\text{ mA}$		350	550	mV
$I_{SC}$	Regulator current limit threshold		50			mA
$I_{BP5}$	Average current				50	
<b>OSCILLATOR</b>						
$f_{SW}$	Switching frequency	TPS40193	240	300	360	kHz
		TPS40192	500	600	700	
$V_{RMP}$	Ramp amplitude <sup>(1)</sup>			1		V
<b>PWM</b>						
$D_{MAX}$	Maximum duty cycle <sup>(1)</sup>		85%			
$t_{ON(min)}$	Minimum controlled pulse <sup>(1)</sup>				110	ns
$t_{DEAD}$	Output driver dead time	HDRV off to LDRV on		50		
		LDRV off to HDRV on		25		
<b>SOFT START</b>						
$t_{SS}$	Soft-start time		3	4	6	ms
$t_{SSDLY}$	Soft-start delay time			2		
$t_{REG}$	Time to regulation			6		
<b>ERROR AMPLIFIER</b>						
GBWP	Gain bandwidth product <sup>(1)</sup>		7	10		MHz
$A_{OL}$	DC gain <sup>(1)</sup>		60			dB
$I_{IB}$	Input bias current (current out of FB pin)				100	nA
$I_{EAOP}$	Output source current	$V_{FB} = 0\text{ V}$	1			mA
$I_{EAOM}$	Output sink current	$V_{FB} = 2\text{ V}$	1			
<b>SHORT CIRCUIT PROTECTION</b>						
$t_{PSS(min)}$	Minimum pulse during short circuit <sup>(1)</sup>			250		ns
$t_{BLNK}$	Blanking time <sup>(1)</sup>		60	90	120	
$t_{OFF}$	Off-time between restart attempts		30	50		ms
$V_{ILIM}$	Short circuit comparator threshold voltage	$R_{COMP(GND)} = \text{OPEN}$ , $T_J = 25^{\circ}\text{C}$	160	200	240	mV
		$R_{COMP(GND)} = 4\text{ k}\Omega$ , $T_J = 25^{\circ}\text{C}$	80	100	120	
		$R_{COMP(GND)} = 12\text{ k}\Omega$ , $T_J = 25^{\circ}\text{C}$	228	280	342	
$V_{ILIMH}$	Short circuit threshold voltage on high-side MOSFET	$T_J = 25^{\circ}\text{C}$	400	550	650	

(1) Specified by design. Not production tested.

## Electrical Characteristics (continued)

 $T_J = -40^{\circ}\text{C}$  to  $85^{\circ}\text{C}$ ,  $V_{VDD} = 12 V_{dc}$ , all parameters at zero power dissipation (unless otherwise noted)

PARAMETER		TEST CONDITIONS	MIN	TYP	MAX	UNIT
<b>OUTPUT DRIVERS</b>						
$R_{HDHI}$	High-side driver pullup resistance	$V_{BOOT} - V_{SW} = 4.5\text{ V}$ , $I_{HDRV} = -100\text{ mA}$		3	6	$\Omega$
$R_{HDLO}$	High-side driver pull-down resistance	$V_{BOOT} - V_{SW} = 4.5\text{ V}$ , $I_{HDRV} = 100\text{ mA}$		1.5	3	
$R_{LDHI}$	Low-side driver pullup resistance	$I_{LDRV} = -100\text{ mA}$		2.5	5	
$R_{LDLO}$	Low-side driver pull-down resistance	$I_{LDRV} = 100\text{ mA}$		0.8	1.5	
$t_{HRISE}$	High-side driver rise time <sup>(1)</sup>	$C_{LOAD} = 1\text{ nF}$		15	35	ns
$t_{H FALL}$	High-side driver fall time <sup>(1)</sup>			10	25	
$t_{LRISE}$	Low-side driver rise time <sup>(1)</sup>			15	35	
$t_{L FALL}$	Low-side driver fall time <sup>(1)</sup>			10	25	
<b>UVLO</b>						
$V_{UVLO}$	Turn-on voltage		3.9	4.2	4.4	V
$UVLO_{HYST}$	Hysteresis		700	800	900	mV
<b>SHUTDOWN</b>						
$V_{IH}$	High-level input voltage, ENABLE			1.9	3	V
$V_{IL}$	Low-level input voltage, ENABLE		0.6			
<b>POWER GOOD</b>						
$V_{OV}$	Feedback voltage limit for power good			650		mV
$V_{UV}$	Feedback voltage limit for power good			525		
$V_{PG\_HYST}$	Powergood hysteresis voltage at FB pin			30		
$R_{PGD}$	Pulldown resistance of PGD pin	$V_{FB} = 0\text{ V}$		7	50	$\Omega$
$I_{PDGLK}$	Leakage current	$V_{FB} = 0\text{ V}$		7	12	$\mu\text{A}$
<b>BOOT DIODE</b>						
$V_{DFWD}$	Bootstrap diode forward voltage	$I_{BOOT} = 5\text{ mA}$	0.5	0.8	1.2	V
<b>THERMAL SHUTDOWN</b>						
$T_{JSD}$	Junction shutdown temperature <sup>(1)</sup>			145		$^{\circ}\text{C}$
$T_{JSDH}$	Hysteresis <sup>(1)</sup>			20		

## 6.6 Dissipation Ratings

PACKAGE	AIRFLOW (LFM)	$R_{\theta JA}$ High-K Board <sup>(1)</sup> ( $^{\circ}\text{C}/\text{W}$ )	Power Rating (W) $T_A = 25^{\circ}\text{C}$	Power Rating (W) $T_A = 85^{\circ}\text{C}$
DRC	0 (Natural Convection)	47.9	2.08	0.835
	200	40.5	2.46	0.987
	400	38.2	2.61	1.04

(1) Ratings based on JEDEC High Thermal Conductivity (High K) Board. For more information on the test method, see TI Technical Brief [SZZA017](#).

### 6.7 Typical Characteristics

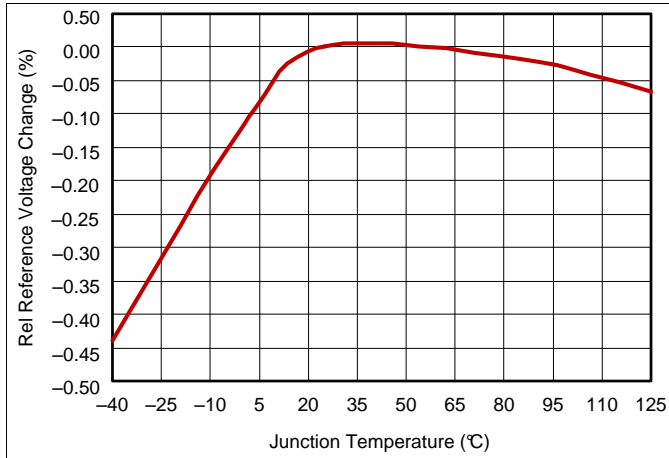

Figure 1. Relative Reference Feedback Voltage vs Junction Temperature

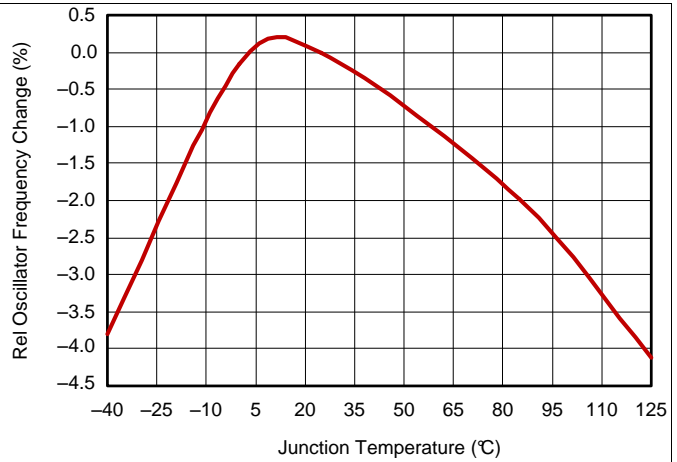

Figure 2. Relative Oscillator Frequency Change vs Junction Temperature

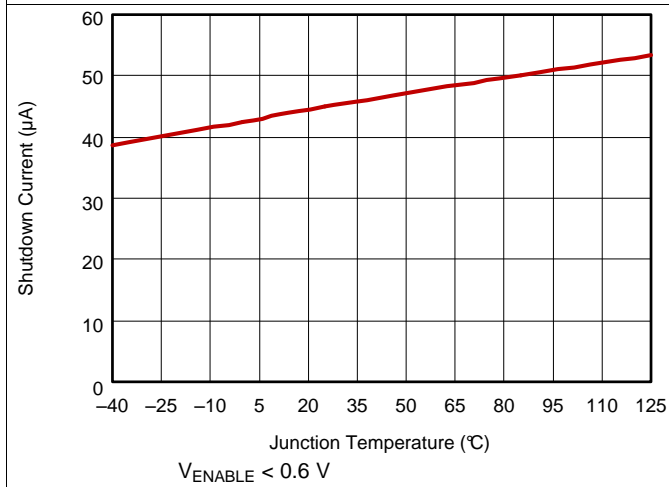

Figure 3. Shutdown Input Current vs Junction Temperature

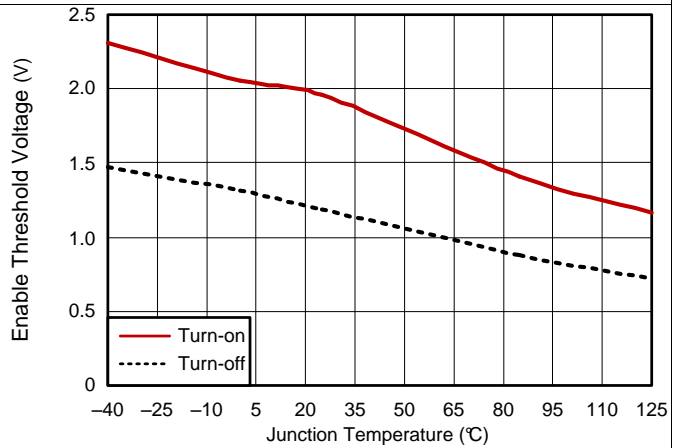

Figure 4. Enable Threshold Voltage vs Junction Temperature

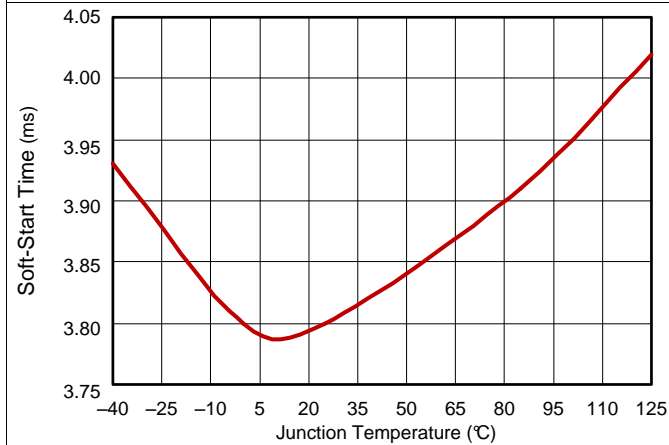

Figure 5. Soft-start Time vs Junction Temperature

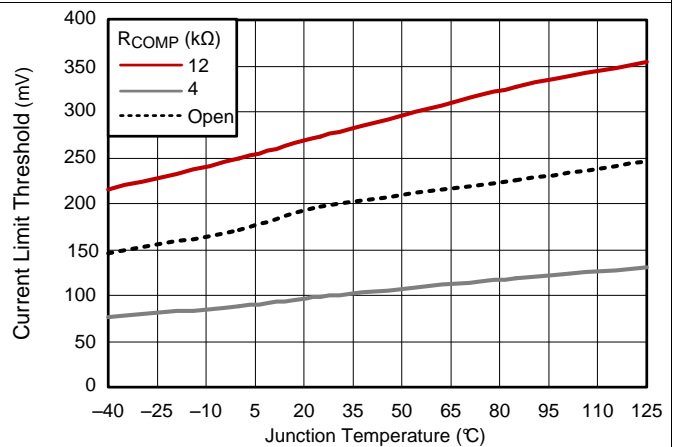

Figure 6. Low-Side MOSFET Current Limit Threshold vs Junction Temperature

Typical Characteristics (continued)

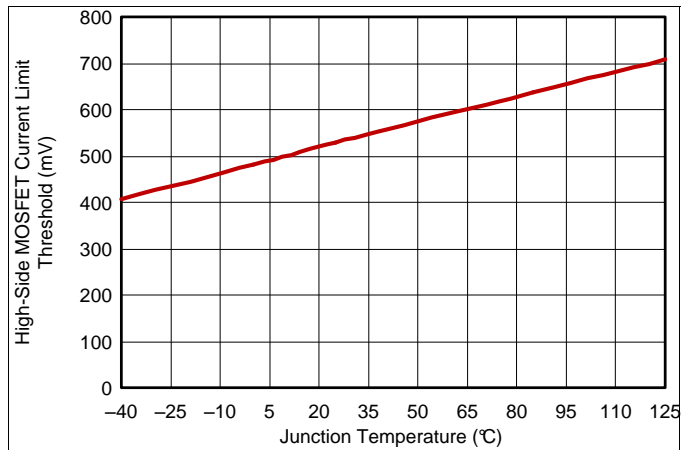

Figure 7. High-Side MOSFET Current Limit Threshold vs Junction Temperature

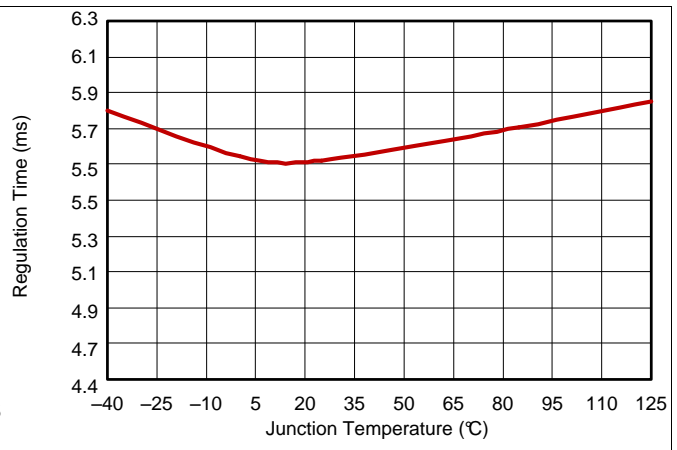

Figure 8. Total Time to Regulation vs Junction Temperature

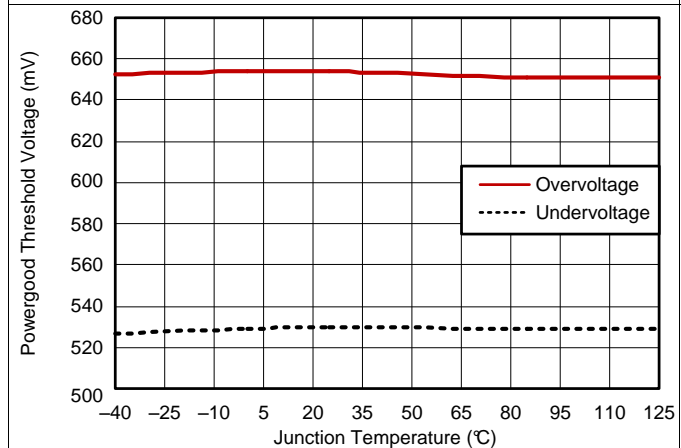

Figure 9. Power-Good Threshold Voltage vs Junction Temperature

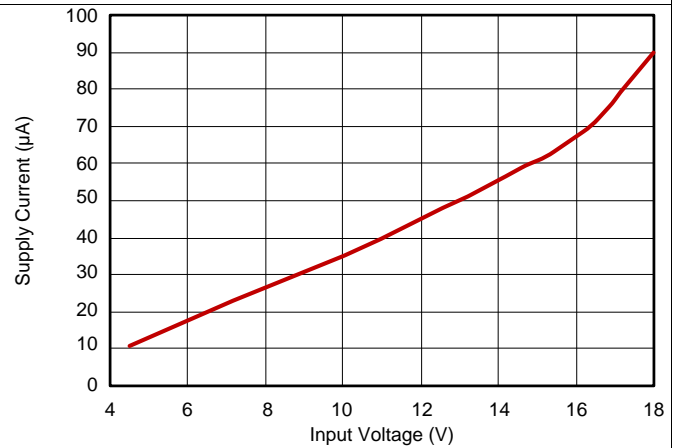

Figure 10. Shutdown Current vs Input Voltage

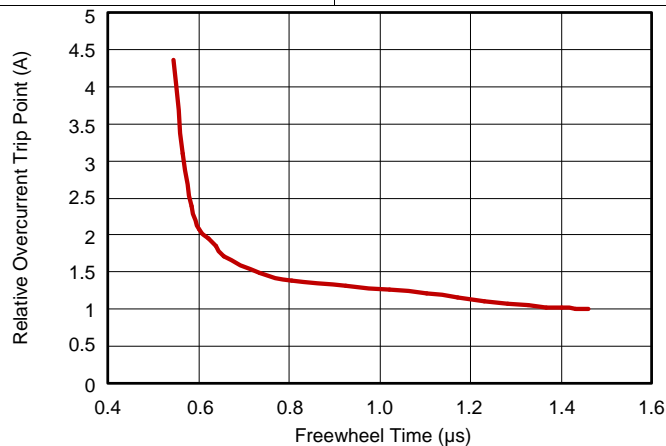

Figure 11. Relative Overcurrent Trip Point vs Freewheel Time

## 7 Detailed Description

### 7.1 Overview

The TPS40192 and TPS40193 devices are cost-optimized controllers providing all the necessary features to construct a high performance DC/DC converter while keeping costs to a minimum. Support for pre-biased outputs eliminates concerns about damaging sensitive loads during start-up. Strong gate drivers for the high-side and rectifier N-channel MOSFETs decrease switching losses for increased efficiency. Adaptive gate drive timing prevents shoot through and minimizes body diode conduction in the rectifier MOSFET, also increasing efficiency. Selectable short circuit protection thresholds and hiccup recovery from a short circuit increase design flexibility and minimize power dissipation in the event of a prolonged output fault. The dedicated ENABLE pin allows the converter to be placed in a very low quiescent current shutdown mode. Internally fixed switching frequency and soft-start time reduce external component count, simplifying design and layout, as well as reducing footprint and cost. The 3-mm x 3-mm package size also contributes to a reduced overall converter footprint.

### 7.2 Functional Block Diagram

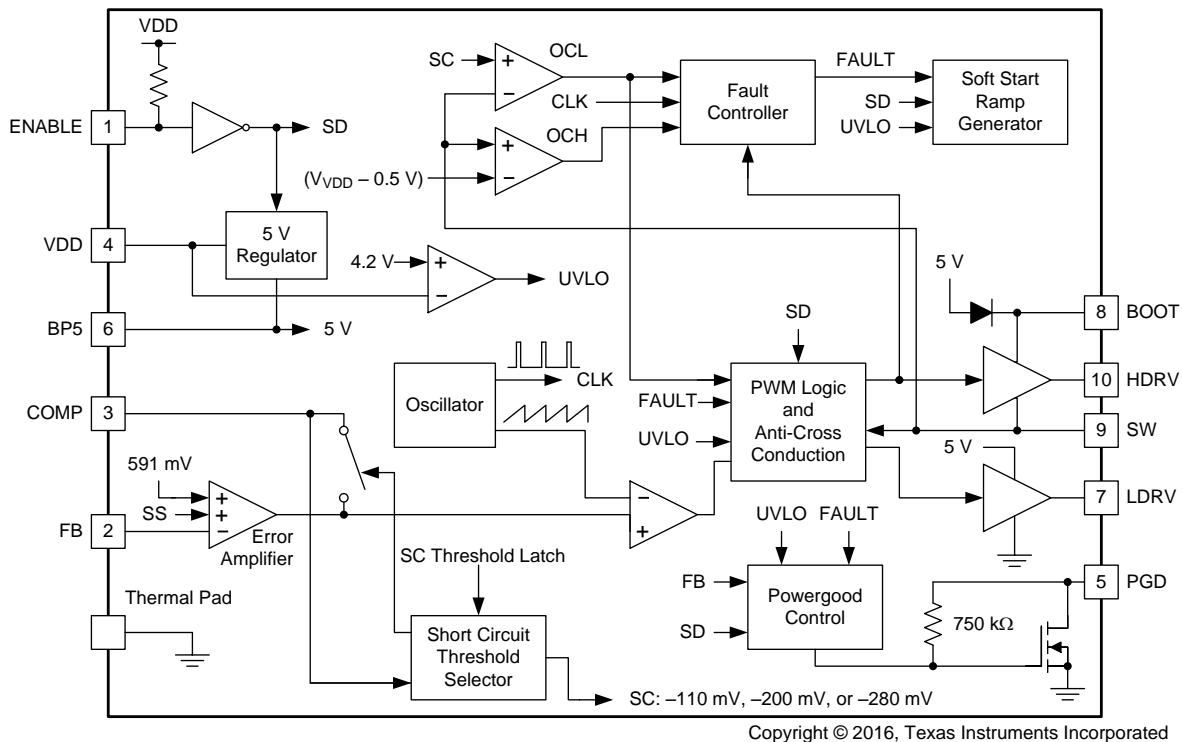

### 7.3 Feature Description

#### 7.3.1 Voltage Reference

The band gap cell is designed with a trimmed 591-mV output. The 0.5% tolerance on the reference voltage allows the user to design a very accurate power-supply.

#### 7.3.2 Oscillator

The TPS40192 has a fixed internal switching frequency of 600 kHz. The TPS40193 operates at a switching frequency of 300 kHz.

## Feature Description (continued)

### 7.3.3 UVLO

When the input voltage is below the UVLO threshold, the device holds all gate drive outputs in the low (OFF) state. When the input rises above the UVLO threshold, and the ENABLE pin is above the turn ON threshold, the oscillator begins to operate and the start-up sequence is allowed to begin. The UVLO level is internally fixed at 4.2 V.

### 7.3.4 Enable Functionality

A dedicated ENABLE pin simplifies a user-level interface design where no multiplexed functions exist. Another benefit is a true low power shutdown mode of operation. When the ENABLE pin is pulled to GND, all unnecessary functions, including the BP5 regulator, are turned off, reducing the device supply ( $I_{DD}$ ) current to 45- $\mu$ A. A functionally equivalent circuit of the enable circuitry shown in Figure 12.

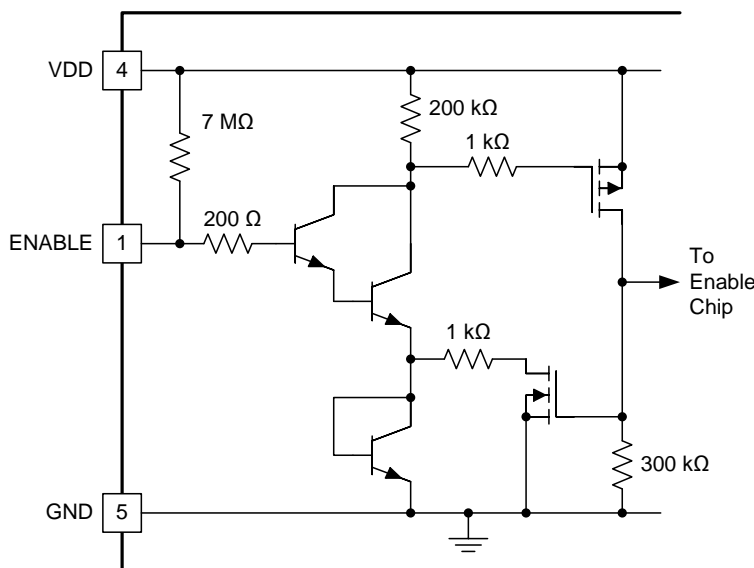

**Figure 12. Enable Pin Internal Circuitry**

If the ENABLE pin is left floating, the chip starts automatically. The pin must be pulled to less than 600 mV to ensure that the TPS40192 and TPS40193 devices are in shutdown mode. Note that the ENABLE pin is relatively high impedance. Some applications generate enough nearby noise to cause the ENABLE pin to swing below the 600 mV threshold and give an erroneous shutdown command to the rest of the device. There are two solutions to solve this problem.

1. Place a capacitor from ENABLE to GND. A side effect of this is to delay the start of the converter while the capacitor charges past the enable threshold
2. Place a resistor from VDD to ENABLE. This causes more current to flow in the shutdown mode, but does not delay converter start-up. If a resistor is used, the total current into the ENABLE pin should be limited to no more than 500  $\mu$ A.

The ENABLE pin is self-clamping. The clamp voltage can be as low as 1 V with a 1-k $\Omega$  ground impedance. Due to this self-clamping feature, the pullup impedance on the ENABLE pin should be selected to limit the sink current to less than 500  $\mu$ A. Driving the ENABLE pin with a low-impedance source voltage can result in damage to the device. Because of the self-clamping feature, it requires care when connecting multiple ENABLE pins together.

## Feature Description (continued)

### 7.3.5 Start-Up Sequence and Timing

After input power is applied, the 5-V onboard regulator comes up. Once this regulator comes up, the device goes through a period where it samples the impedance at the COMP pin and determines the short circuit protection threshold voltage, by placing 400 mV on the COMP pin for approximately 1 ms. During this time, the current is measured and compared against internal thresholds to select the short circuit protection threshold. After this, the COMP pin is brought low for 1 ms. This ensures that the feedback loop is preconditioned at start-up and no sudden output rise occurs at the output of the converter when the converter is allowed to start switching. After these initial two milliseconds, the internal soft-start circuitry is engaged and the converter is allowed to start. See Figure 13.

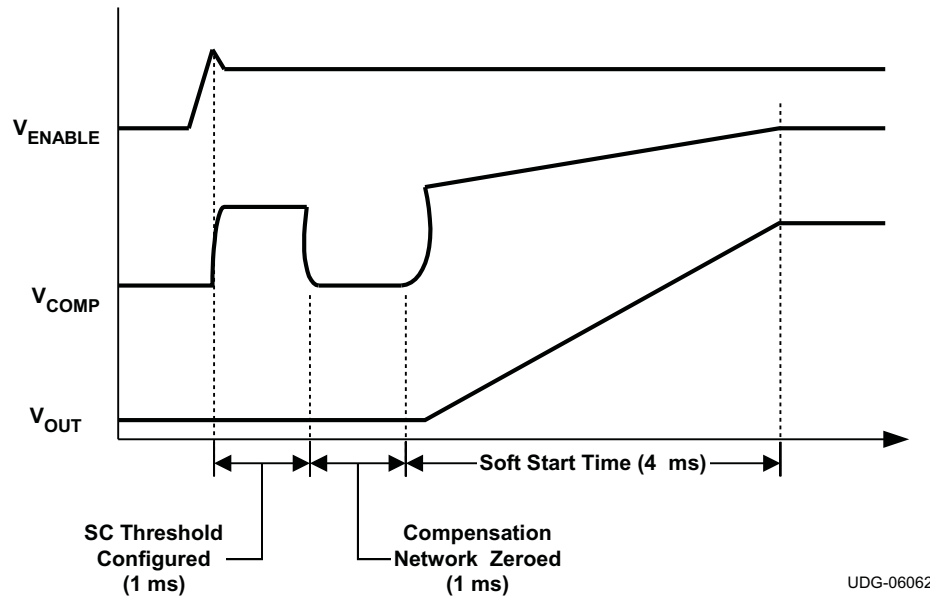

Figure 13. Start-Up Sequence

### 7.3.6 Selecting the Short Circuit Current

A short circuit in the devices is detected by sensing the voltage drop across the low-side MOSFET when it is on, and across the high-side MOSFET when it is on. If the voltage drop across either MOSFET exceeds the short circuit threshold in any given switching cycle, a counter increments one count. If the voltage across the high-side MOSFET was higher than the short circuit threshold, that MOSFET is turned off early. If the voltage drop across either MOSFET does not exceed the short circuit threshold during a cycle, the counter is decremented for that cycle. If the counter fills up (a count of 7) a fault condition is declared and the drivers turn off both MOSFETs. After a timeout of approximately 50 ms, the controller attempts to restart. If a short circuit is still present at the output, the current quickly ramps up to the short circuit threshold and another fault condition is declared and the process of waiting for the 50 ms attempting to restart repeats. The low-side threshold increases as the low-side on time decreases due to blanking time and comparator response time. See Figure 11 for changes in the threshold as the low-side MOSFET conduction time decreases.

These devices provide three selectable short circuit protection thresholds for the low-side MOSFET: 100 mV, 200 mV and 280 mV. The particular threshold is selected by connecting a resistor from COMP to GND. Table 1 shows the short circuit thresholds for corresponding resistors from COMP to GND. When designing the compensation for the feedback loop, remember that a low impedance compensation network combined with a long network time constant can cause the short circuit threshold setting to not be as expected. The time constant and impedance of the network connected from COMP to FB should be as in Equation 1 to ensure no interaction with the short circuit threshold setting.

**Feature Description (continued)**

$$\frac{0.4 \text{ V}}{R1} \times e^{\left(\frac{-t}{R1 \times C1}\right)} < 10 \mu\text{A}$$

where

- t is 1 ms, the sampling time of the short circuit threshold setting circuit
- R1 and C1 are the values of the components in [Figure 14](#)

(1)

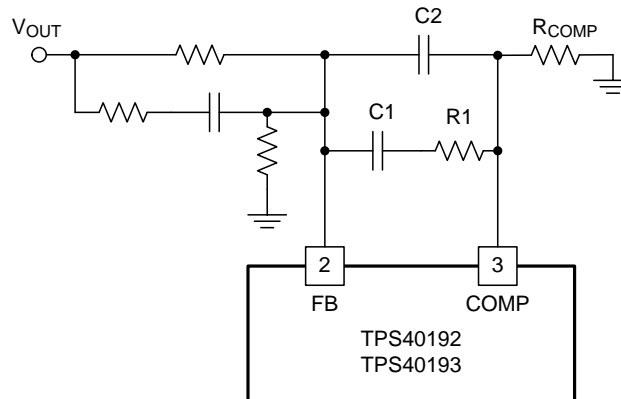
**Figure 14. Short Circuit Threshold Feedback Network**
**Table 1. Short Circuit Threshold Voltage Selection**

COMPARATOR RESISTANCE R <sub>COMP</sub> (kΩ)	CURRENT LIMIT THRESHOLD VOLTAGE (mV) V <sub>ILIM</sub> (V)
12 ±10%	280
Open	200
4 ±10%	100

The range of short circuit current thresholds that can be expected is shown in [Equation 2](#) and [Equation 3](#).

$$I_{SCP(\max)} = \frac{V_{ILIM(\max)}}{R_{DS(on)\min}}$$

(2)

$$I_{SCP(\min)} = \frac{V_{ILIM(\min)}}{R_{DS(on)\max}}$$

where

- I<sub>SCP</sub> is the short circuit current
- V<sub>ILIM</sub> is the short circuit threshold for the low-side MOSFET
- R<sub>DS(on)</sub> is the channel ON-resistance of the low-side MOSFET

(3)

Due to blanking time considerations, overcurrent threshold accuracy may fall off for duty cycle greater than 75% with the TPS40192, or 88% with the TPS40193. Specifically, the overcurrent comparator has only a very short time to sample the SW pin voltage under these conditions. As a result, the comparator may not have time to respond to voltages very near the threshold.

The short circuit protection threshold for the high-side MOSFET is fixed at 550 mV typical, 400 mV minimum. This threshold is in place to provide a maximum current output using pulse by pulse current limit in the case of a fault. The pulse terminates when the voltage drop across the high-side MOSFET exceeds the short circuit threshold. The maximum amount of current that can be specified to be sourced from a converter is found by [Equation 4](#).

$$I_{OUT(max)} = \frac{V_{ILIM(min)}}{R_{DS(on)max}}$$

where

- $I_{OUT(max)}$  is the maximum current that the converter is specified to source
  - $V_{ILIM(min)}$  is the short circuit threshold for the high-side MOSFET (400 mV)
  - $R_{DS(on)max}$  is the maximum resistance of the high-side MOSFET
- (4)

If the required current from the converter is greater than the calculated  $I_{OUT(max)}$ , a lower resistance high-side MOSFET must be chosen. Both the high-side and low-side thresholds use temperature compensation to approximate the change in resistance for a typical power MOSFET. This helps to counteract shifts in overcurrent thresholds as temperature increases. For this feature to be effective, the MOSFETs and the device must be well coupled thermally.

### 7.3.7 5-V Regulator

An on board 5-V regulator that allows the parts to operate from a single voltage feed. No separate 5-V feed to the part is required. This regulator needs to have a minimum of 1- $\mu$ F of capacitance on the BP5 pin for stability. A ceramic capacitor is suggested for this purpose.

This regulator can also be used to supply power to nearby circuitry, eliminating the need for a separate LDO in some cases. If this pin is used for external loads, be aware that this is the power supply for the internals of the TPS40192 and TPS40193 devices. While efforts have been made to reduce sensitivity, any noise induced on this line has an adverse effect on the overall performance of the internal circuitry and shows up as increased pulse jitter, or skewed reference voltage. Also, when the device is disabled by pulling the EN pin low, this regulator is turned off and cannot supply power.

The amount of power available from this pin varies with the size of the power MOSFETs that the drivers must operate. Larger MOSFETs require more gate drive current and reduce the amount of power available on this pin for other tasks. The total current that this pin can draw from both the gate drive and external loads cannot exceed 50 mA. The device uses up to 4 mA from the regulator and the total gate drive current can be found from [Equation 5](#).

For regulator stability, a 1- $\mu$ F capacitor is required to be connected from BP5 to GND. In some applications using higher gate charge MOSFETs, a larger capacitor is required for noise suppression. For a total gate charge of both the high and low-side MOSFETs greater than 20 nC, a 2.2- $\mu$ F or larger capacitor is recommended.

$$I_G = f_{SW} \times (Q_{G(high)} + Q_{G(low)})$$

where

- $I_G$  is the required gate drive current
  - $f_{SW}$  is the switching frequency (600 kHz for TPS40192, and 300 kHz for TPS40193)
  - $Q_{G(high)}$  is the gate charge requirement for the high-side MOSFET when  $V_{GS} = 5$  V
  - $Q_{G(low)}$  is the gate charge requirement for the low-side MOSFET when  $V_{GS} = 5$  V
- (5)

### 7.3.8 Prebias Start-Up

The TPS40192 and TPS40193 devices contains a unique circuit to prevent current from being *pulled* from the output during start-up in the condition the output is pre-biased. When the soft-start commands a voltage higher than the pre-bias level (internal soft-start becomes greater than feedback voltage [ $V_{FB}$ ]), the controller slowly activates synchronous rectification by starting the first LDRV pulses with a narrow on-time. It then increments that on-time on a cycle-by-cycle basis until it coincides with the time dictated by (1-D), where D is the duty cycle of the converter. This scheme prevents the initial sinking of the pre-bias output, and ensures that the out voltage ( $V_{OUT}$ ) starts and ramps up smoothly into regulation and the control loop is given time to transition from pre-biased start-up to normal mode operation with minimal disturbance to the output voltage. The amount of time from the start of switching until the low-side MOSFET is turned on for the full (1-D) interval is defined by 32 clock cycles.

### 7.3.9 Drivers

The drivers for the external HDRV and LDRV MOSFETs are capable of driving a gate-to-source voltage of 5 V. The LDRV driver switches between VDD and GND, while HDRV driver is referenced to SW and switches between BOOT and SW. The drivers have non-overlapping timing that is governed by an adaptive delay circuit to minimize body diode conduction in the synchronous rectifier. The drivers are capable of driving MOSFETS that are appropriate for a 15-A (TPS40192) or 20-A (TPS40193) converter.

### 7.3.10 Power Good

The TPS40192 and TPS40193 devices provides an indication that output power is good for the converter. This is an open drain signal and pulls low when any condition exists that would indicate that the output of the supply might be out of regulation. These conditions include:

- $V_{FB}$  is more than  $\pm 10\%$  from nominal
- soft-start is active
- an undervoltage condition exists for the device
- a short circuit condition has been detected
- die temperature is over (145°C)

---

#### NOTE

When there is no power to the device, PGOOD is not able to pull close to GND if an auxiliary supply is used for the power good indication. In this case, a built in resistor connected from drain to gate on the PGOOD pull down device makes the PGOOD pin look approximately like a diode to GND.

---

### 7.3.11 Thermal Shutdown

If the junction temperature of the device reaches the thermal shutdown limit of 145°C, the PWM and the oscillator are turned off and the HDRV pin and the LDRV pin are driven low, turning off both FETs. When the junction cools to the required level (125°C nominal), the PWM initiates soft start as during a normal power up cycle.

## 7.4 Device Functional Modes

### 7.4.1 Continuous Conduction Mode

The TPS40192 and TPS40193 devices operate in continuous conduction mode, regardless of the output current. Following the first 32 cycles, during which the low-side MOSFET on-time is slowly increased to prevent current sinking due to a pre-biased output, the high-side MOSFET and low-side MOSFET on-times are fully complementary.

### 7.4.2 Low-Quiescent Shutdown

When the ENABLE pin of the TPS40192, and TPS40193 devices is held below 0.6 V, the device enters a low quiescent current shutdown mode, drawing only 45  $\mu$ A typically from the VDD pin.

## 8 Application and Implementation

### NOTE

Information in the following applications sections is not part of the TI component specification, and TI does not warrant its accuracy or completeness. TI's customers are responsible for determining suitability of components for their purposes. Customers should validate and test their design implementation to confirm system functionality.

### 8.1 Application Information

This example illustrates the design process and component selection for a 12 V to 1.8 V point-of-load synchronous buck regulator using the TPS40192. A definition of symbols used can be found in Table 7 of this data sheet.

### 8.2 Typical Application

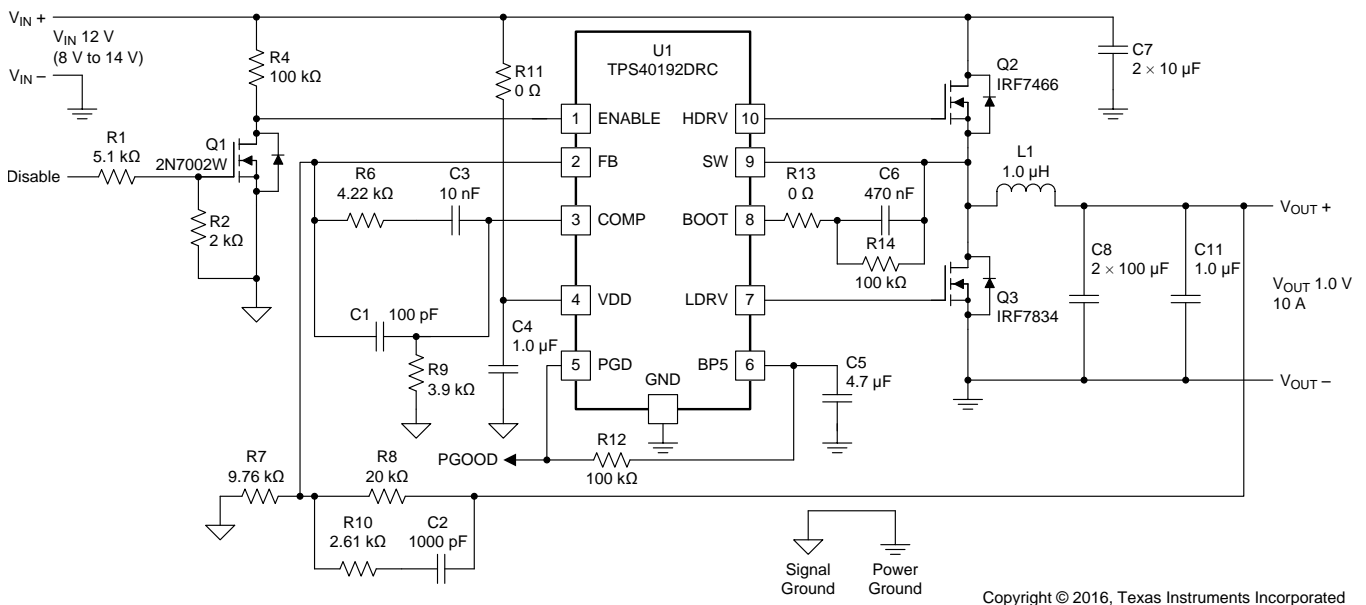

Figure 15. TPS40192 Design Example Schematic

## Typical Application (continued)

### 8.2.1 Design Requirements

The requirements for this design are summarized in [Table 2](#).

**Table 2. Design Requirements**

Parameter		Notes and Conditions	Min	Nom	Max	Units
<b>Input Characteristics</b>						
V <sub>IN</sub>	Input voltage		8	12	14	V
I <sub>IN</sub>	Input current	V <sub>IN</sub> = 8 V, I <sub>OUT</sub> = 10 A		2.7	2.85	A
	No load input current	V <sub>IN</sub> = 8 V, I <sub>OUT</sub> = 0 A		48	60	mA
VIN_UVLO	Input UVLO	0 A ≤ I <sub>OUT</sub> ≤ 10 A	3.9	4.2	4.4	V
<b>Output Characteristics</b>						
V <sub>OUT</sub>	Output voltage	V <sub>IN</sub> = 12 V, I <sub>OUT</sub> = 6 A		1.8		V
	Line regulation	8 V ≤ V <sub>IN</sub> ≤ 14 V, I <sub>OUT</sub> = 6 A			0.5%	
	Load regulation	V <sub>IN</sub> = 12 V, 0 A ≤ I <sub>OUT</sub> ≤ 10 A			0.5%	
V <sub>OUT(ripple)</sub>	Output voltage ripple	V <sub>IN</sub> = 12 V, I <sub>OUT</sub> = 10 A			40	mVpp
I <sub>OUT</sub>	Output current	8 V ≤ V <sub>IN</sub> ≤ 14	0	6	10	A
I <sub>OCP</sub>	Output overcurrent inception point	V <sub>IN</sub> = 12 V, V <sub>OUT</sub> = V <sub>OUT</sub> – 5%		19		A
<b>Transient Response</b>						
ΔI	Load step	0.75 × I <sub>OUT(max)</sub> to 0.25 × I <sub>OUT(max)</sub>		5		A
	Load slew rate			5		A/μsec
	Overshoot				50	mV
<b>Systems Characteristics</b>						
f <sub>SW</sub>	Switching frequency		480	600	720	kHz
η <sub>pk</sub>	Peak efficiency	V <sub>IN</sub> = 8 V, 0 A ≤ I <sub>OUT</sub> ≤ 10 A		89%		
η	Full-load efficiency	V <sub>IN</sub> = 8 V, I <sub>OUT</sub> ≤ 10 A		86%		
T <sub>J</sub>	Operating temperature range	8 V ≤ V <sub>IN</sub> ≤ 14 V, 0 A ≤ I <sub>OUT</sub> ≤ 10 A	-40	25	60	°C

### 8.2.2 Detailed Design Procedure

#### 8.2.2.1 Selecting the Switching Frequency

Choose a switching f<sub>SW</sub> of 600 kHz to reduce the required inductor and capacitor sizes.

#### 8.2.2.2 Inductor Selection

The inductor is typically sized for approximately 30% peak-to-peak ripple current (I<sub>RIPPLE</sub>). Given this target ripple current, the required inductor size can be calculated by [Equation 6](#).

$$L \approx \frac{V_{IN(max)} - V_{OUT}}{I_{RIPPLE}} \times \frac{V_{OUT}}{V_{IN(max)}} \times \frac{1}{f_{SW}} = \frac{14 \text{ V} - 1.8 \text{ V}}{0.3 \times 10 \text{ A}} \times \frac{1.8 \text{ V}}{14 \text{ V}} \times \frac{1}{600 \text{ kHz}} = 0.87 \mu\text{H} \quad (6)$$

A standard value of 1 μH is selected. Solving for I<sub>RIPPLE</sub> using an inductor value of 1 μH, results in 2.6-A peak-to-peak ripple.

The RMS current through the inductor is approximated by [Equation 7](#).

$$\begin{aligned} I_{L(rms)} &= \sqrt{(I_{L(avg)})^2 + \frac{1}{12} \times (I_{RIPPLE})^2} = \sqrt{(I_{OUT})^2 + \frac{1}{12} \times (I_{RIPPLE})^2} \\ &= \sqrt{(10 \text{ A})^2 + \frac{1}{12} \times (2.6 \text{ A})^2} \approx 10.03 \text{ A} \end{aligned} \quad (7)$$

Using [Equation 7](#), the maximum RMS current in the inductor is approximately 10.03 A

### 8.2.2.3 Output Capacitor Selection (C8)

The selection of the output capacitor is typically driven by the output transient response. The [Equation 8](#) and [Equation 9](#) overestimate the voltage deviation to account for delays in the loop bandwidth and can be used to determine the required output capacitance.

$$V_{\text{OVER}} < \frac{I_{\text{TRAN}}}{C_{\text{OUT}}} \times \Delta t = \frac{I_{\text{TRAN}}}{C_{\text{OUT}}} \times \frac{I_{\text{TRAN}} \times L}{V_{\text{OUT}}} = \frac{(I_{\text{TRAN}})^2 \times L}{V_{\text{OUT}} \times C_{\text{OUT}}} \quad (8)$$

$$V_{\text{UNDER}} < \frac{I_{\text{TRAN}}}{C_{\text{OUT}}} \times \Delta t = \frac{I_{\text{TRAN}}}{C_{\text{OUT}}} \times \frac{I_{\text{TRAN}} \times L}{(V_{\text{IN}} - V_{\text{OUT}})} = \frac{(I_{\text{TRAN}})^2 \times L}{(V_{\text{IN}} - V_{\text{OUT}}) \times C_{\text{OUT}}}$$

If

- $V_{\text{IN}(\text{min})} > 2 \times V_{\text{OUT}}$ , use overshoot to calculate minimum output capacitance.
- $V_{\text{IN}(\text{min})} < 2 \times V_{\text{OUT}}$ , use undershoot to calculate minimum output capacitance.

$$C_{\text{OUT}(\text{min})} = \frac{(I_{\text{TRAN}(\text{max})})^2 \times L}{V_{\text{OUT}} \times V_{\text{OVER}}} = \frac{(4 \text{ A})^2 \times 1.0 \mu\text{H}}{1.8 \text{ V} \times 50 \text{ mV}} = 178 \mu\text{F} \quad (10)$$

With a minimum capacitance, the maximum allowable ESR is determined by the maximum ripple voltage and is approximated by [Equation 11](#).

$$\begin{aligned} \text{ESR}_{\text{MAX}} &< \frac{V_{\text{RIPPLE}(\text{tot})} - V_{\text{RIPPLE}(\text{cap})}}{C_{\text{OUT}}} = \frac{V_{\text{RIPPLE}(\text{tot})} - \left( \frac{I_{\text{RIPPLE}}}{C_{\text{OUT}} \times f_{\text{SW}}} \right)}{I_{\text{RIPPLE}}} \\ &= \frac{36 \text{ mV} - \left( \frac{2.6 \text{ A}}{178 \mu\text{F} \times 600 \text{ kHz}} \right)}{2.6 \text{ A}} = 4.4 \text{ m}\Omega \end{aligned} \quad (11)$$

Two 1206 100- $\mu\text{F}$ , 6.3-V X5R ceramic capacitors are selected to provide more than 178- $\mu\text{F}$  of minimum capacitance and less than 4.4 m $\Omega$  of ESR (2.5 m $\Omega$  each).

### 8.2.2.4 Peak Current Rating of the Inductor

With output capacitance, it is possible to calculate the charge current during start-up and determine the minimum saturation current rating for the inductor. The start-up charging current is approximated by [Equation 12](#).

$$I_{\text{CHARGE}} = \frac{V_{\text{OUT}} \times C_{\text{OUT}}}{t_{\text{SS}}} = \frac{1.8 \text{ V} \times 200 \mu\text{F}}{3.0 \text{ ms}} = 120 \text{ mA} \quad (12)$$

$$I_{\text{L}(\text{peak})} = I_{\text{OUT}(\text{max})} + \left( \frac{1}{2} \times I_{\text{RIPPLE}} \right) + I_{\text{CHARGE}} = 10 \text{ A} + \left( \frac{1}{2} \times 2.6 \text{ A} \right) + 120 \text{ mA} = 11.4 \text{ A} \quad (13)$$

**Table 3. Inductor Requirements**

PARAMETER	SYMBOL	VALUE	UNITS
Inductance	L	1	$\mu\text{H}$
RMS current (thermal rating)	$I_{\text{L}(\text{rms})}$	10.03	A
Peak current (saturation rating)	$I_{\text{L}(\text{peak})}$	11.4	

A PG0083.102 1- $\mu\text{H}$  is selected for its small size, low DCR (6.6 m $\Omega$ ) and high current handling capability (12 A thermal, 17 A saturation)

### 8.2.2.5 Input Capacitor Selection (C7)

The input voltage ripple is divided between capacitance and ESR. For this design  $V_{\text{RIPPLE}(\text{cap})} = 400 \text{ mV}$  and  $V_{\text{RIPPLE}(\text{ESR})} = 200 \text{ mV}$ . Use [Equation 14](#) to estimate the minimum capacitance and maximum ESR.

$$C_{\text{IN}(\text{min})} = \frac{I_{\text{OUT}} \times V_{\text{OUT}}}{V_{\text{RIPPLE}(\text{cap})} \times V_{\text{IN}(\text{MIN})} \times f_{\text{SW}}} = \frac{10 \text{ A} \times 1.8 \text{ V}}{400 \text{ mV} \times 8 \text{ V} \times 600 \text{ kHz}} = 9.375 \mu\text{F} \quad (14)$$

$$ESR_{MAX} = \frac{V_{RIPPLE (esr)}}{I_{OUT} + \left(\frac{1}{2} \times I_{RIPPLE}\right)} = \frac{200 \text{ mV}}{10 \text{ A} + \left(\frac{1}{2} \times 2.6 \text{ A}\right)} = 17.7 \text{ m}\Omega \quad (15)$$

For this design  $C_{IN(min)} > 9.375 \mu\text{F}$  and  $ESR < 17.7 \text{ m}\Omega$ . Use [Equation 16](#) to estimate the RMS current in the input capacitors.

$$I_{RMS (cin)} = I_{IN (rms)} - I_{IN (avg)} = \left(I_{OUT} + \frac{1}{12} \times I_{RIPPLE}\right) \times \sqrt{\frac{V_{OUT}}{V_{IN}} - \frac{V_{OUT} \times I_{OUT}}{V_{IN}}} \\ = \left(10 \text{ A} + \frac{1}{12} \times 2.6 \text{ A}\right) \times \sqrt{\frac{1.8 \text{ V}}{14 \text{ V}} - \frac{1.8 \text{ V} \times 10 \text{ A}}{14 \text{ V}}} = 2.37 \text{ A} \quad (16)$$

The total input capacitance must support 2.37 A of RMS ripple current.

Two 1210 10- $\mu\text{F}$ , 25 V, X5R ceramic capacitors with approximately 2 m $\Omega$  ESR and a 2-A<sub>RMS</sub> current rating are selected. Higher voltage capacitors minimize capacitance loss at the DC bias voltage to ensure the capacitors have sufficient capacitance at the working voltage.

### 8.2.2.6 MOSFET Switch Selection (Q1, Q2)

The switching losses for the high-side MOSFET are estimated by [Equation 17](#).

$$P_{G1SW} = \frac{1}{2} \times V_{IN} \times I_{OUT} \times \Delta t_{SW} \times f_{SW} = \frac{1}{2} \times V_{IN} \times I_{OUT} \times \frac{Q_{GD1}}{\frac{V_{DRV} - V_{TH}}{R_{DRV}}} \times f_{SW} \quad (17)$$

Switching losses in this design are highest at high-line. Designing for 1 W of total loss in each MOSFET and 60% of the total high-side MOSFET losses in switching losses, estimate the maximum gate-drain charge for the design by using [Equation 18](#).

$$Q_{GD1 (max)} = \frac{P_{G1SW}}{V_{IN} \times I_{OUT}} \times \frac{V_{DRV} - V_{TH}}{R_{DRV}} \times \frac{1}{f_{SW}} = \frac{600 \text{ mW}}{14 \text{ V} \times 10 \text{ A}} \times \frac{5 \text{ V} - 2 \text{ V}}{2.5 \Omega} \times \frac{1}{600 \text{ kHz}} = 8.6 \text{ nC} \quad (18)$$

The switching losses of the synchronous rectifier are lower than the switching losses of the main MOSFET because the voltage across the MOSFET at the point of switching is reduced to the forward voltage drop across the body diode of the SR MOSFET and are estimated by using [Equation 19](#). The conduction losses in the main MOSFET are estimated by the RMS current through the MOSFET times its  $R_{DS(on)}$ .

$$P_{G1(CON)} = I_{L(rms)} \times R_{DS(on)Q1} \times \frac{V_{OUT}}{V_{IN}} \quad (19)$$

Estimating about 40% of total MOSFET losses to be high-side conduction losses, the maximum  $R_{DS(on)}$  of the high-side MOSFET can be estimated by using [Equation 20](#).

$$R_{DS(on)Q1,MAX} = \frac{P_{Q1CON}}{(I_{L(rms)})^2 \times \frac{V_{OUT}}{V_{IN}}} = \frac{400 \text{ mW}}{(10.03 \text{ A})^2 \times \frac{1.8 \text{ V}}{14 \text{ V}}} = 30.9 \text{ m}\Omega \quad (20)$$

Estimating 80% of total low-side MOSFET losses in conduction losses, repeat the calculation for the synchronous rectifier, whose losses are dominated by the conduction losses. Calculate the maximum  $R_{DS(on)}$  of the synchronous rectifier by [Equation 21](#).

$$R_{DS(on)Q2,MAX} = \frac{P_{Q2CON}}{(I_{L(rms)})^2 \times \left(1 - \frac{V_{OUT}}{V_{IN}}\right)} = \frac{800 \text{ mW}}{10.03^2 \times \left(1 - \frac{1.8 \text{ V}}{14 \text{ V}}\right)} = 9.1 \text{ m}\Omega \quad (21)$$

**Table 4. Power MOSFET Requirements**

PARAMETER	SYMBOL	VALUE	UNITS
High-side MOSFET on-resistance	$R_{DS(on)Q1}$	30.9	m $\Omega$
High-side MOSFET gate-to-drain charge	$Q_{GD1}$	8.5	nC
Low-side MOSFET on-resistance	$R_{DS(on)Q2}$	8.8	m $\Omega$

The IRF7466 has an  $R_{DS(on)MAX}$  of 30.9 m $\Omega$  at 4.5-V gate drive and only 8.0-nC  $V_{GD}$  "Miller" charge with a 4.5-V gate drive, and is chosen as a high-side MOSFET. The IRF7834 has an  $R_{DS(on)Q1,MAX}$  of 5.5 m $\Omega$  at 4.5-V gate drive and 44 nC of total gate charge. These two FETs have maximum total gate charges of 23 nC and 44 nC respectively, which draws 40.2-mA from the 5-V regulator, less than its 50-mA minimum rating.

### 8.2.2.7 Boot Strap Capacitor

To ensure proper charging of the high-side MOSFET gate, limit the ripple voltage on the boost capacitor to less than 50 mV.

$$C_{BOOST} = 20 \times Q_{G1} = 20 \times 23 \text{ nC} = 460 \text{ nF} \quad (22)$$

Use the next higher standard value of 470 nF for the value of the bootstrap capacitor.

#### NOTE

It is recommended to add a high-resistance resistor in parallel with the bootstrap capacitor. Adding a small amount of load to the bootstrap capacitor (100 k $\Omega$  for a 100-nF typical capacitor) creates a discharge time constant for the bootstrap voltage following a shutdown event. This prevents the possibility of an inadvertent turn-on of the high-side MOSFET following shutdown via the ENABLE pin, due to leakage paths within the driver stage which can slowly transfer the bootstrap voltage to the HDRV pin following the shutdown. (See [Figure 15](#))

### 8.2.2.8 Input Bypass Capacitor (C6)

As suggested, select a 1.0- $\mu$ F ceramic bypass capacitor for VDD.

### 8.2.2.9 BP5 Bypass Capacitor (C5)

The recommended minimum 1.0- $\mu$ F ceramic capacitance stabilizes the 5-V regulator. To limit regulator noise to less than 10 mV, the bypass capacitor is sized by using [Equation 23](#).

$$C_{BP5} = 100 \times \text{MAX}(Q_{G1}, Q_{G2}) = 100 \times \text{MAX}(23 \text{ nC}, 44 \text{ nC}) \cong 4.4 \mu\text{F} \quad (23)$$

Because the Q2 gate charge is larger than Q1 and the total gate charge of Q2 is 44 nC, a BP5 capacitor of 4.4- $\mu$ F is calculated, and the next larger standard value of 4.7  $\mu$ F is selected to limit noise on the BP5 regulator.

### 8.2.2.10 Input Voltage Filter Resistor (R11)

Because the minimum input voltage ( $V_{IN(min)}$ ) is greater than 6.0 V, place a 0- $\Omega$  resistor in the VDD resistor location. If  $V_{IN(min)}$  was < 6.0 V, an optional series VDD resistor with a value between 1  $\Omega$  and 2  $\Omega$  filters switching noise from the device. Limit the voltage drop across this resistor to less than 50 mV.

$$R_{VDD} = \frac{V_{RVDD(max)}}{I_{DD}} = \frac{50 \text{ mV}}{3 \text{ mA} + (Q_{G1,tot} + Q_{G2,tot}) \times f_{SW}} = \frac{50 \text{ mV}}{3 \text{ mA} + (44 \text{ nC} + 23 \text{ nC}) \times 600 \text{ kHz}}$$

$$= \frac{50 \text{ mV}}{43 \text{ mA}} \cong 1 \Omega \quad (24)$$

Driving the two FETs with 23 nC and 44 nC respectively, the maximum  $I_{VDD}$  current calculation of 43 mA yields a resistor value of approximately 1  $\Omega$ .

### 8.2.2.11 Short Circuit Protection (R9)

The devices use the negative drop across the low-side MOSFET during the OFF time to measure the inductor current. [Equation 25](#) approximates the voltage drop across the low-side MOSFET.

$$V_{CS(max)} = I_{L(peak)} \times R_{DS(on),Q2,MAX} = 11.4 \text{ A} \times 5.5 \text{ m}\Omega \cong 62.7 \text{ mV} \quad (25)$$

The internal temperature coefficient of the TPS40192 device helps compensate for the MOSFET on-resistance ( $R_{DS(on)}$ ) temperature coefficient. For this design select the short circuit protection voltage threshold of 110 mV by selecting  $R_9 = 3.9 \text{ k}\Omega$ .

### 8.2.2.12 Feedback Compensation (Modeling the Power Stage)

The DC gain of the modulator is given by [Equation 26](#).

$$A_{MOD} = \frac{dV_{OUT}}{dV_{COMP}} = \frac{dD}{V_{COMP}} \times V_{IN} = \frac{dt}{dV_{RAMP}} \times \frac{1}{t_{SW}} \times V_{IN} \quad (26)$$

Because the peak-to-peak ramp voltage given in the [Electrical Characteristics](#) table is projected from the ramp slope over a full switching period, the modulator gain can be calculated as [Equation 27](#). The maximum modulator gain for this design is found to be 14 (23 dB).

$$A_{MOD(max)} = \frac{V_{IN(max)}}{V_{RAMP(pp)}} = \frac{14 \text{ V}}{1 \text{ V}_{PP}} = 14 \quad (27)$$

The L-C filter applies a double pole at the resonance frequency described in [Equation 28](#).

$$f_{RES} = \frac{1}{2\pi \times \sqrt{L \times C}} = \frac{1}{2\pi \times \sqrt{1 \mu\text{H} \times 200 \mu\text{F}}} \cong 11.3 \text{ kHz} \quad (28)$$

At any frequency lower than this ( 11.3 kHz), the power stage has a DC gain of 23 dB and at any higher frequency the power stage gain drops off at -40 dB per decade. The ESR zero is approximated in [Equation 29](#).

$$f_{ESR} = \frac{1}{2\pi \times C_{OUT} \times R_{ESR}} = \frac{1}{2\pi \times (2 \times 100 \mu\text{F}) \times \left(\frac{2.5 \text{ m}\Omega}{2}\right)} = 636 \text{ kHz} \quad (29)$$

Using two 100  $\mu\text{F}$ , 2.5 m $\Omega$  ESR ceramic output capacitors, the calculated  $f_{ESR}$  of 636 kHz is greater than 1/5th the switching frequency, and therefore outside the scope of the error amplifier design. The gain of the power stage would change to -20 dB per decade above  $f_{ESR}$ . The straight line approximation the power stage gain is described in [Figure 16](#).

The following compensation design procedure assumes  $f_{ESR} > f_{RES}$ . For designs using large high-ESR bulk capacitors on the output where  $f_{ESR} < f_{RES}$ . Type-II compensation can be used but is not described in this data sheet.

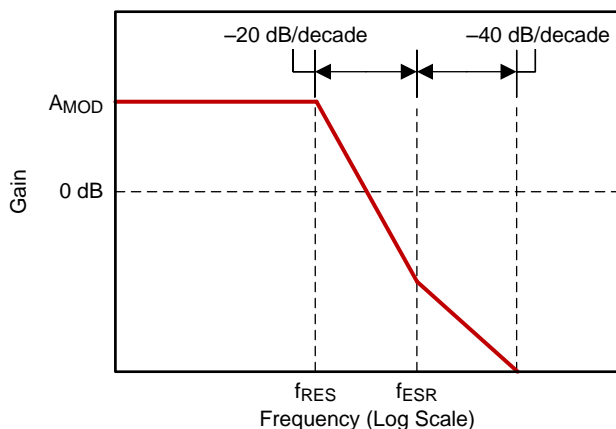

**Figure 16. Approximation of Power Stage Gain**

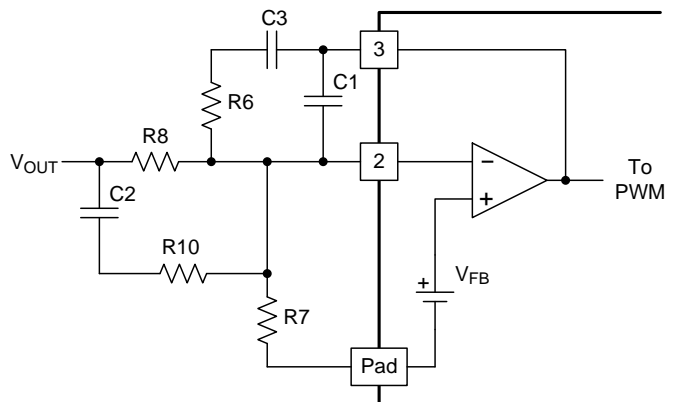

**Figure 17. Type-III Compensator Used with TPS40040 or TPS40041**

### 8.2.2.13 Feedback Divider ( $R_7$ , $R_8$ )

Select a value for  $R_8$  between 10 k $\Omega$  and 100 k $\Omega$ . For this design, select 20 k $\Omega$ .  $R_7$  is then selected to produce the desired output voltage when  $V_{FB} = 0.591 \text{ V}$  using [Equation 30](#).

$$R7 = \frac{V_{FB} \times R8}{V_{OUT} - V_{FB}} = \frac{0.591 \text{ V} \times 20 \text{ k}\Omega}{1.8 \text{ V} - 0.591 \text{ V}} = 9.78 \text{ k}\Omega \quad (30)$$

Select the closest standard value of 9.76 kΩ. A slightly lower nominal value increases the nominal output voltage slightly to compensate for some trace impedance at load.

### 8.2.2.14 Error Amplifier Compensation (R6, R10, C1, C2, C3)

Place two zeros at 50% and 100% of the resonance frequency to boost the phase margin before resonance frequency generates  $-180^\circ$  of phase shift. For  $f_{RES} = 11.7 \text{ kHz}$ ,  $f_{Z1} = 5.8 \text{ kHz}$  and  $f_{Z2} = 11 \text{ kHz}$ . Selecting the crossover frequency ( $f_{CO}$ ) of the control loop between 3 times the LC filter resonance and 1/5th the switching frequency. For most applications 1/10th the switching frequency provides a good balance between ease of design and fast transient response.

- If  $f_{ESR} < f_{CO}$ ;  $f_{P1} = f_{ESR}$  and  $f_{P2} = 4 \times f_{CO}$
- If  $f_{ESR} > 2 \times f_{CO}$ ;  $f_{P1} = f_{CO}$  and  $f_{P2} = 8 \times f_{CO}$ .

For this design

- $f_{SW} = 600 \text{ kHz}$
- $f_{RES} = 11.7 \text{ kHz}$
- $f_{ESR} = 636 \text{ kHz}$
- $f_{CO} = 60 \text{ kHz}$  and because
- $f_{ESR} > 2 \times f_{CO}$ ,  $f_{P1} = f_{CO} = 60 \text{ kHz}$  and  $f_{P2} = 4 \times f_{CO} = 500 \text{ kHz}$ .

Because  $f_{CO} < f_{ESR}$  the power stage gain at the desired crossover can be approximated in [Equation 31](#).

$$A_{PS(f_{CO})} = A_{MOD(dC)} - 40 \log\left(\frac{f_{CO}}{f_{RES}}\right) = 10^{A_{PS(f_{CO})}/20} = 10^{5.4 \text{ dB}/20} = 1.86 \quad (31)$$

**Table 5. Error Amplifier Design Parameters**

PARAMETER	SYMBOL	VALUE	UNITS
First zero frequency	$f_{Z1}$	5.8	kHz
Second zero frequency	$f_{Z2}$	11.0	
First pole frequency	$f_{P1}$	60	
Second pole frequency	$f_{P2}$	500	
Midband gain	$A_{MID(\text{band})}$	1.86	V/V

Approximate C2 with the formula described in [Equation 32](#).

$$C2 = \frac{1}{2\pi \times R8 \times f_{Z2}} = \frac{1}{2\pi \times 20 \text{ k}\Omega \times 11 \text{ kHz}} = 723 \text{ pF} \quad (32)$$

For a calculated value for C2 of 723 pF, the closest standard capacitor value is 1000 pF.

Approximate R10 using [Equation 33](#).

$$R10 = \frac{1}{2\pi \times C2 \times f_{P1}} = \frac{1}{2\pi \times 1000 \text{ pF} \times 60 \text{ kHz}} = 2.65 \text{ k}\Omega \quad (33)$$

For a calculated value for R10 of 2.65 kΩ, the closest standard resistor value is 2.61 kΩ.

Calculate R6 using [Equation 34](#).

$$R6 = \frac{A_{MID(\text{band})} \times R10 \times R8}{R10 + R8} = \frac{1.86 \times 2.61 \text{ k}\Omega \times 20 \text{ k}\Omega}{2.61 \text{ k}\Omega + 20 \text{ k}\Omega} = 4.29 \text{ k}\Omega \quad (34)$$

For a calculated value for R6 of 4.29 kΩ, the closest standard resistor value is 4.22 kΩ.

Calculate C1 and C3 using [Equation 35](#) and [Equation 36](#).

$$C3 = \frac{1}{2\pi \times R6 \times f_{Z1}} = \frac{1}{2\pi \times 4.22 \text{ k}\Omega \times 5.8 \text{ kHz}} = 6.5 \text{ nF} \quad (35)$$

$$C1 = \frac{1}{2\pi \times R6 \times f_{p2}} = \frac{1}{2\pi \times 4.22 \text{ k}\Omega \times 500 \text{ kHz}} = 75 \text{ pF} \tag{36}$$

Using the a standard value close to 75 pF, select C1 = 100 pF. Likewise, using a standard value close to 6.5 nF, select C3 = 10 nF.

The error amplifier straight line approximation transfer function is described in Figure 18.

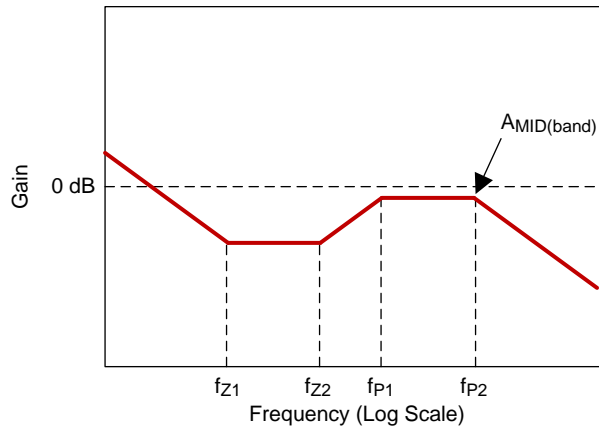

Figure 18. Error Amplifier Transfer Function Approximation

### 8.2.3 Application Curves

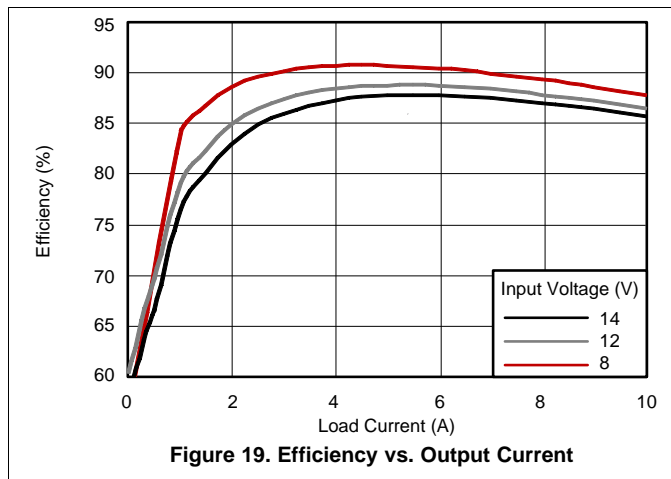

Figure 19. Efficiency vs. Output Current

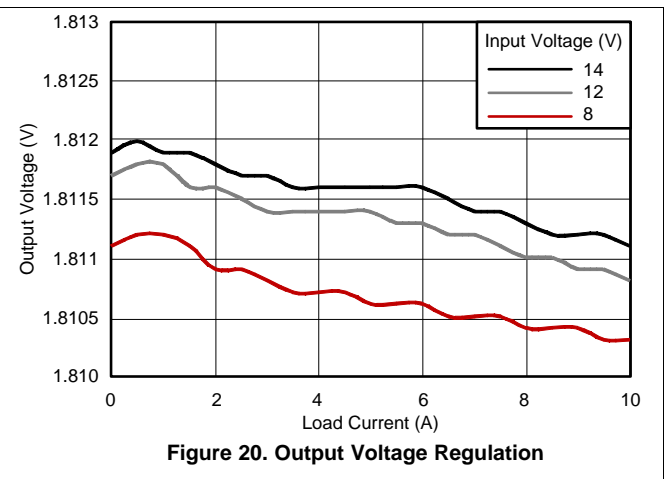

Figure 20. Output Voltage Regulation

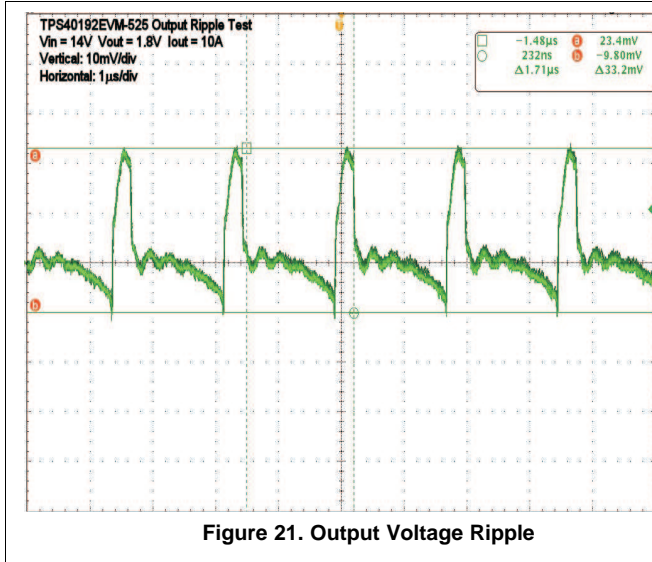

Figure 21. Output Voltage Ripple

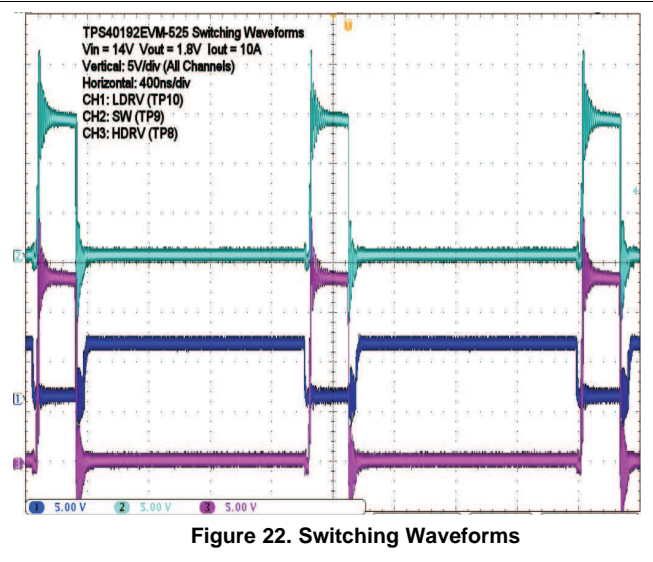

Figure 22. Switching Waveforms

## 9 Power Supply Recommendations

The TPS40192, and TPS40193 devices are designed to operate from a supply on the VDD pin, ranging from 4.5 V to 18 V. This supply must be well regulated and bypassed for proper operation of the devices. The VDD pin must be connected to the same supply as the power stage conversion input voltage for accurate high-side current sensing. The BP5 pin is the output of an internal low dropout regulator which is used to supply the gate drive voltages, and must also have good local bypassing for proper operation of the devices.

## 10 Layout

### 10.1 Layout Guidelines

- Optionally use R11 as a VDD filter resistor
- Locate the bypass capacitors (C7) near the power MOSFETs.
- Terminate signal components to a signal ground island separate from power ground
- Connect signal ground island to thermal pad with a single 10-mil wide trace.
- Connect power ground to the source of the synchronous rectifier.
- The thermal pad serves as the only ground for the controller.
- PowerPAD must be connected to signal ground and power ground at a single point only. Connect the PowerPAD to the system ground.
- PowerPAD™ should be directly connected to SYNC MOSFET (Q3) source with short, wide trace.
- Locate 3-5 vias in PowerPAD™ land to remove heat from the device.
- Connect input capacitors (C7 and C9) and output capacitors (C8 and C10) grounds directly to SYNC MOSFET (Q3) source with wide copper trace or solid power ground island.
- Locate input capacitors (C7 and C9), MOSFETs (Q2 and Q3), inductor (L1) and output capacitor (C8 and C10) over power ground island.
- Use short, wide traces for LDRV and HDRV MOSFET connections.
- Route SW trace near HDRV trace.
- Route GND trace near LDRV trace.
- Use separate analog ground island under feedback components (C1, C2, C3, R5, R6, R7, R8 and R10).
- Connect ground islands at PowerPAD™ with 10-mil wide trace opposite SYNC MOSFET (Q2) source connection.

### 10.2 Layout Examples

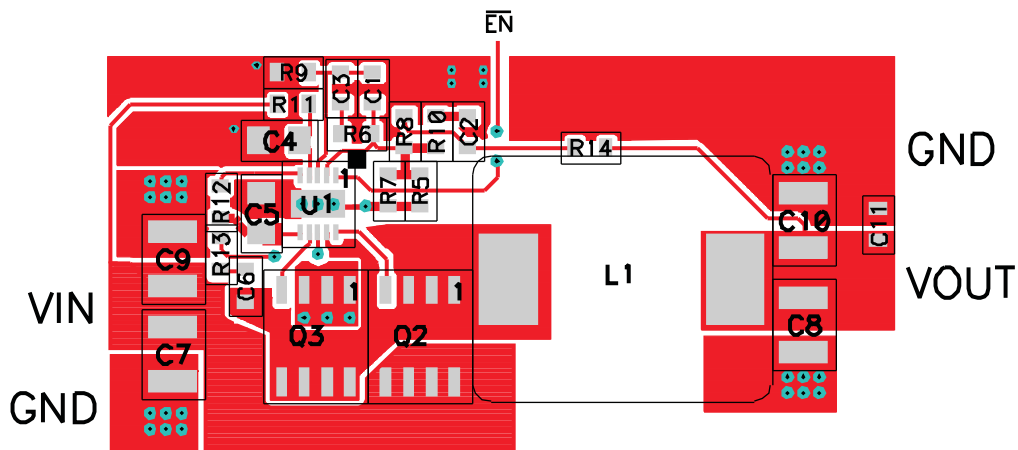

Figure 23. TPS40192 and TPS40193 Devices Sample Layout - Component Placement and Top Side Copper

## Layout Examples (continued)

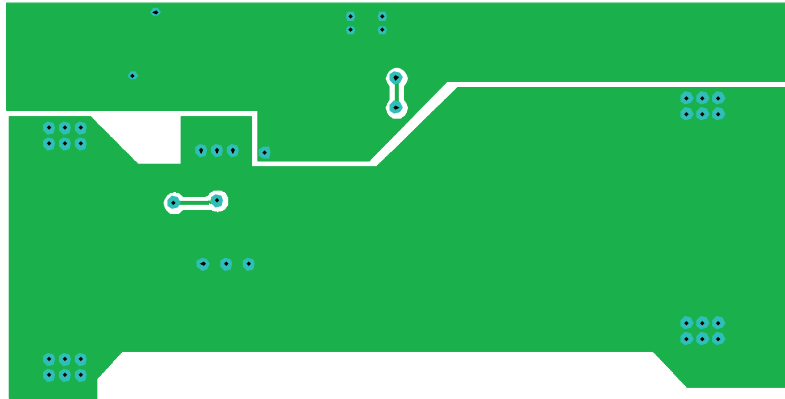

Figure 24. TPS40192 and TPS40193 Devices Sample Layout - Bottom Side Copper (X-Ray view from Top)

## 11 Device and Documentation Support

### 11.1 Device Support

#### 11.1.1 Development Support

##### 11.1.1.1 Related Devices

The following devices have characteristics similar to the TPS40192 and TPS40193.

**Table 6. Related Devices**

DEVICE	DESCRIPTION
TPS40100	Midrange Input Synchronous Controller with Advanced Sequencing and Output Margining
TPS40075	Wide Input Synchronous Controller with Voltage Feed Forward

#### 11.1.2 Device Nomenclature

**Table 7. Definition of Symbols**

SYMBOL	DESCRIPTION
$V_{IN(max)}$	Maximum operating input voltage
$V_{IN(min)}$	Minimum operating input voltage
$V_{IN(ripple)}$	Peak- to-peak AC ripple voltage on $V_{IN}$
$V_{OUT}$	Target output voltage
$V_{OUT(ripple)}$	Peak- to-peak AC ripple voltage on $V_{OUT}$
$I_{OUT(max)}$	Maximum operating load current
$I_{RIPPLE}$	Peak-to-Peak ripple current through Inductor
$I_{L(peak)}$	Peak current through inductor
$I_{L(rms)}$	Root mean squared current through inductor
$I_{RMS(Cin)}$	Root mean squared current through input capacitor
$f_{SW}$	Switching frequency
$f_{CO}$	Desired control loop crossover frequency
$A_{MOD}$	Low frequency gain of the pwm modulator ( $V_{OUT} / V_{CONTROL}$ )
$V_{CONTROL}$	PWM control voltage (error amplifier output voltage $V_{COMP}$ )
$f_{RES}$	L-C filter resonant frequency
$f_{ESR}$	Output capacitor ESR zero frequency
$f_{P1}$	First pole frequency in error amplifier compensation
$f_{P2}$	Second pole frequency in error amplifier compensation
$f_{Z1}$	First zero frequency in error amplifier compensation
$f_{Z2}$	Second pole frequency in error amplifier compensation
$Q_{G1}$	Total gate charge of main MOSFET
$Q_{G2}$	Total gate charge of synchronous rectifier MOSFET
$R_{DS(on)Q1}$	"ON" drain-to-source resistance of main MOSFET
$R_{DS(on)Q2}$	"ON" drain-to-source resistance of synchronous rectifier MOSEFT
$P_{Q1C(on)}$	Conduction losses in main switching MOSFET
$P_{Q1SW}$	Switching losses in main switching MOSFET
$P_{Q2C(on)}$	Conduction losses in synchronous rectifier MOSFET
$Q_{GD}$	Gate-to-drain charge of synchronous rectifier MOSFET
$Q_{GS}$	Gate-t-source charge of synchronous rectifier MOSFET

## 11.2 Documentation Support

Access these reference documents as well as design tools and links to additional references, including design software at [www.power.ti.com](http://www.power.ti.com).

- [Under The Hood Of Low Voltage DC/DC Converters](#), SEM1500 Topic 5, 2002 Seminar Series
- [Understanding Buck Power Stages in Switchmode Power Supplies](#), March 1999
- [Design and Application Guide for High Speed MOSFET Gate Drive Circuits](#), SEM 1400, 2001 Seminar Series
- [Designing Stable Control Loops](#), SEM 1400, 2001 Seminar Series
- [PowerPAD™ Thermally Enhanced Package](#) Application Report
- [PowerPAD™ Made Easy](#) Application Report
- [QFN/SON PCB Attachment](#) Application Report

## 11.3 Related Links

The table below lists quick access links. Categories include technical documents, support and community resources, tools and software, and quick access to sample or buy.

**Table 8. Related Links**

PARTS	PRODUCT FOLDER	SAMPLE & BUY	TECHNICAL DOCUMENTS	TOOLS & SOFTWARE	SUPPORT & COMMUNITY
TPS40192	<a href="#">Click here</a>	<a href="#">Click here</a>	<a href="#">Click here</a>	<a href="#">Click here</a>	<a href="#">Click here</a>
TPS40193	<a href="#">Click here</a>	<a href="#">Click here</a>	<a href="#">Click here</a>	<a href="#">Click here</a>	<a href="#">Click here</a>

## 11.4 Receiving Notification of Documentation Updates

To receive notification of documentation updates, navigate to the device product folder on ti.com. In the upper right corner, click on *Alert me* to register and receive a weekly digest of any product information that has changed. For change details, review the revision history included in any revised document.

## 11.5 Community Resources

The following links connect to TI community resources. Linked contents are provided "AS IS" by the respective contributors. They do not constitute TI specifications and do not necessarily reflect TI's views; see TI's [Terms of Use](#).

**TI E2E™ Online Community** *TI's Engineer-to-Engineer (E2E) Community*. Created to foster collaboration among engineers. At [e2e.ti.com](http://e2e.ti.com), you can ask questions, share knowledge, explore ideas and help solve problems with fellow engineers.

**Design Support** *TI's Design Support* Quickly find helpful E2E forums along with design support tools and contact information for technical support.

## 11.6 Trademarks

E2E is a trademark of Texas Instruments.  
All other trademarks are the property of their respective owners.

## 11.7 Electrostatic Discharge Caution



These devices have limited built-in ESD protection. The leads should be shorted together or the device placed in conductive foam during storage or handling to prevent electrostatic damage to the MOS gates.

## 11.8 Glossary

**SLYZ022** — *TI Glossary*.

This glossary lists and explains terms, acronyms, and definitions.

## 12 Mechanical, Packaging, and Orderable Information

The following pages include mechanical, packaging, and orderable information. This information is the most current data available for the designated devices. This data is subject to change without notice and revision of this document. For browser-based versions of this data sheet, refer to the left-hand navigation.

## PACKAGING INFORMATION

Orderable Device	Status (1)	Package Type	Package Drawing	Pins	Package Qty	Eco Plan (2)	Lead/Ball Finish (6)	MSL Peak Temp (3)	Op Temp (°C)	Device Marking (4/5)	Samples
HPA00351DRCR	ACTIVE	VSON	DRC	10	3000	Green (RoHS & no Sb/Br)	CU NIPDAU	Level-2-260C-1 YEAR	-40 to 85	0193	<a href="#">Samples</a>
TPS40192DRCR	ACTIVE	VSON	DRC	10	3000	Green (RoHS & no Sb/Br)	CU NIPDAU	Level-2-260C-1 YEAR	-40 to 85	0192	<a href="#">Samples</a>
TPS40192DRCT	ACTIVE	VSON	DRC	10	250	Green (RoHS & no Sb/Br)	CU NIPDAU	Level-2-260C-1 YEAR	-40 to 85	0192	<a href="#">Samples</a>
TPS40193DRCR	ACTIVE	VSON	DRC	10	3000	Green (RoHS & no Sb/Br)	CU NIPDAU	Level-2-260C-1 YEAR	-40 to 85	0193	<a href="#">Samples</a>
TPS40193DRCRG4	ACTIVE	VSON	DRC	10	3000	Green (RoHS & no Sb/Br)	CU NIPDAU	Level-2-260C-1 YEAR	-40 to 85	0193	<a href="#">Samples</a>
TPS40193DRCT	ACTIVE	VSON	DRC	10	250	Green (RoHS & no Sb/Br)	CU NIPDAU	Level-2-260C-1 YEAR	-40 to 85	0193	<a href="#">Samples</a>

(1) The marketing status values are defined as follows:

**ACTIVE:** Product device recommended for new designs.

**LIFEBUY:** TI has announced that the device will be discontinued, and a lifetime-buy period is in effect.

**NRND:** Not recommended for new designs. Device is in production to support existing customers, but TI does not recommend using this part in a new design.

**PREVIEW:** Device has been announced but is not in production. Samples may or may not be available.

**OBSOLETE:** TI has discontinued the production of the device.

(2) **RoHS:** TI defines "RoHS" to mean semiconductor products that are compliant with the current EU RoHS requirements for all 10 RoHS substances, including the requirement that RoHS substance do not exceed 0.1% by weight in homogeneous materials. Where designed to be soldered at high temperatures, "RoHS" products are suitable for use in specified lead-free processes. TI may reference these types of products as "Pb-Free".

**RoHS Exempt:** TI defines "RoHS Exempt" to mean products that contain lead but are compliant with EU RoHS pursuant to a specific EU RoHS exemption.

**Green:** TI defines "Green" to mean the content of Chlorine (Cl) and Bromine (Br) based flame retardants meet JS709B low halogen requirements of <=1000ppm threshold. Antimony trioxide based flame retardants must also meet the <=1000ppm threshold requirement.

(3) MSL, Peak Temp. - The Moisture Sensitivity Level rating according to the JEDEC industry standard classifications, and peak solder temperature.

(4) There may be additional marking, which relates to the logo, the lot trace code information, or the environmental category on the device.

(5) Multiple Device Markings will be inside parentheses. Only one Device Marking contained in parentheses and separated by a "~" will appear on a device. If a line is indented then it is a continuation of the previous line and the two combined represent the entire Device Marking for that device.

<sup>(6)</sup> Lead/Ball Finish - Orderable Devices may have multiple material finish options. Finish options are separated by a vertical ruled line. Lead/Ball Finish values may wrap to two lines if the finish value exceeds the maximum column width.

**Important Information and Disclaimer:**The information provided on this page represents TI's knowledge and belief as of the date that it is provided. TI bases its knowledge and belief on information provided by third parties, and makes no representation or warranty as to the accuracy of such information. Efforts are underway to better integrate information from third parties. TI has taken and continues to take reasonable steps to provide representative and accurate information but may not have conducted destructive testing or chemical analysis on incoming materials and chemicals. TI and TI suppliers consider certain information to be proprietary, and thus CAS numbers and other limited information may not be available for release.

In no event shall TI's liability arising out of such information exceed the total purchase price of the TI part(s) at issue in this document sold by TI to Customer on an annual basis.

**TAPE AND REEL INFORMATION**

**QUADRANT ASSIGNMENTS FOR PIN 1 ORIENTATION IN TAPE**

\*All dimensions are nominal

Device	Package Type	Package Drawing	Pins	SPQ	Reel Diameter (mm)	Reel Width W1 (mm)	A0 (mm)	B0 (mm)	K0 (mm)	P1 (mm)	W (mm)	Pin1 Quadrant
TPS40192DRCR	VSON	DRC	10	3000	330.0	12.4	3.3	3.3	1.1	8.0	12.0	Q2
TPS40192DRCT	VSON	DRC	10	250	180.0	12.4	3.3	3.3	1.1	8.0	12.0	Q2
TPS40193DRCR	VSON	DRC	10	3000	330.0	12.4	3.3	3.3	1.1	8.0	12.0	Q2
TPS40193DRCT	VSON	DRC	10	250	180.0	12.4	3.3	3.3	1.1	8.0	12.0	Q2

**TAPE AND REEL BOX DIMENSIONS**

\*All dimensions are nominal

Device	Package Type	Package Drawing	Pins	SPQ	Length (mm)	Width (mm)	Height (mm)
TPS40192DRCR	VSON	DRC	10	3000	367.0	367.0	35.0
TPS40192DRCT	VSON	DRC	10	250	210.0	185.0	35.0
TPS40193DRCR	VSON	DRC	10	3000	367.0	367.0	35.0
TPS40193DRCT	VSON	DRC	10	250	210.0	185.0	35.0

## GENERIC PACKAGE VIEW

DRC 10

VSON - 1 mm max height

PLASTIC SMALL OUTLINE - NO LEAD

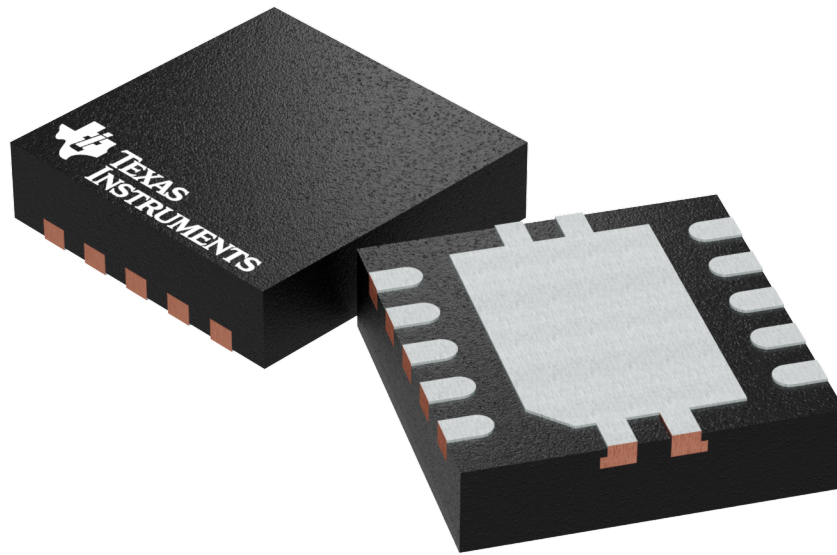

Images above are just a representation of the package family, actual package may vary.  
Refer to the product data sheet for package details.

4204102-3/M

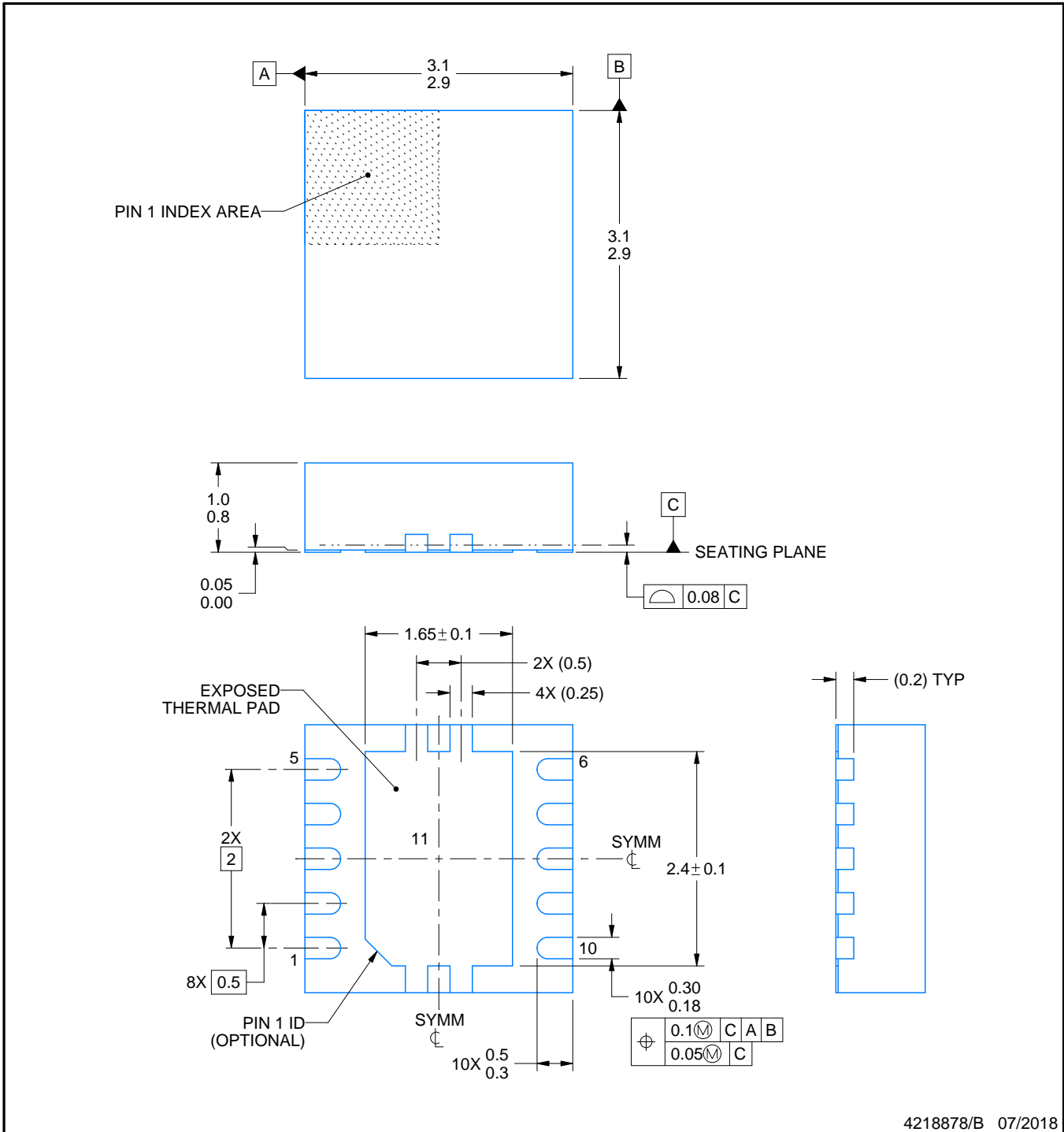

4218878/B 07/2018

NOTES:

1. All linear dimensions are in millimeters. Any dimensions in parenthesis are for reference only. Dimensioning and tolerancing per ASME Y14.5M.
2. This drawing is subject to change without notice.
3. The package thermal pad must be soldered to the printed circuit board for optimal thermal and mechanical performance.

# EXAMPLE BOARD LAYOUT

DRC0010J

VSON - 1 mm max height

PLASTIC SMALL OUTLINE - NO LEAD

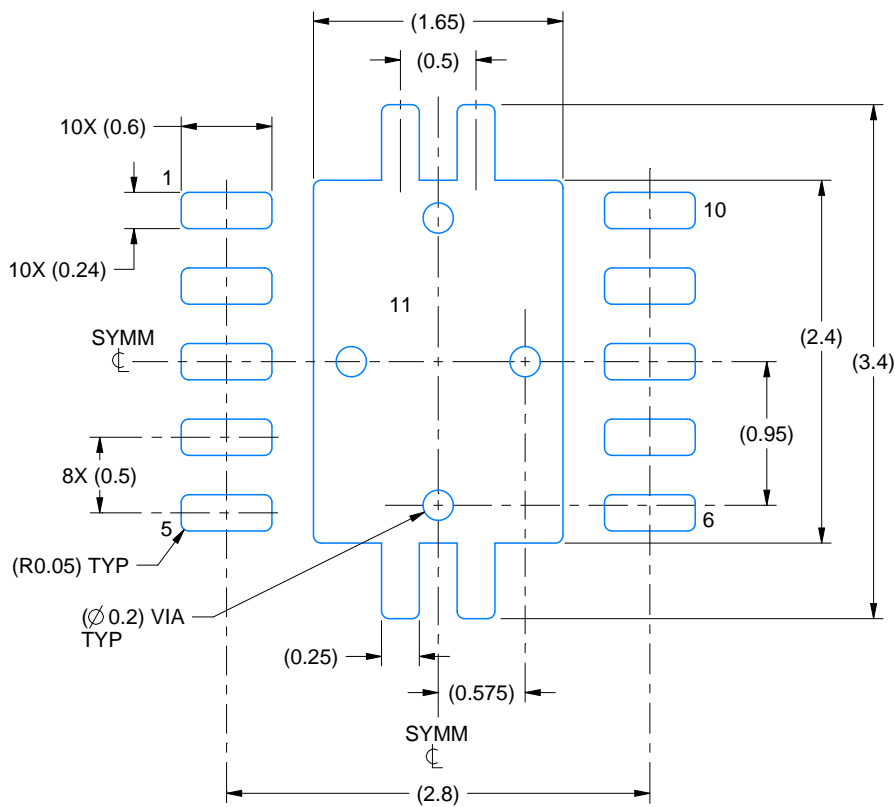

LAND PATTERN EXAMPLE  
EXPOSED METAL SHOWN  
SCALE:20X

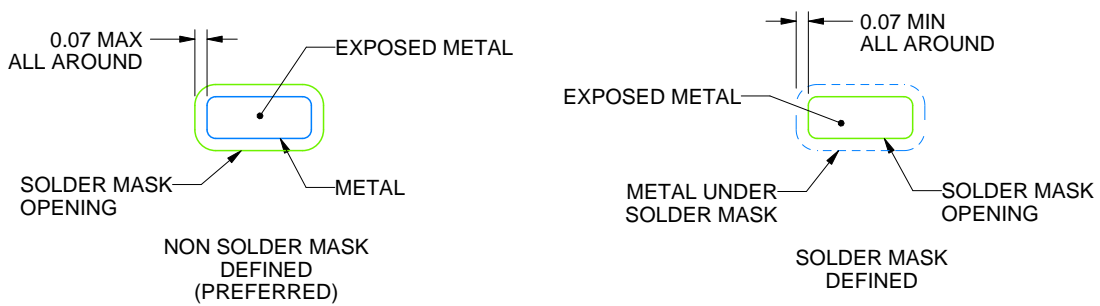

SOLDER MASK DETAILS

4218878/B 07/2018

NOTES: (continued)

4. This package is designed to be soldered to a thermal pad on the board. For more information, see Texas Instruments literature number SLUA271 ([www.ti.com/lit/slua271](http://www.ti.com/lit/slua271)).
5. Vias are optional depending on application, refer to device data sheet. If any vias are implemented, refer to their locations shown on this view. It is recommended that vias under paste be filled, plugged or tented.

# EXAMPLE STENCIL DESIGN

DRC0010J

VSON - 1 mm max height

PLASTIC SMALL OUTLINE - NO LEAD

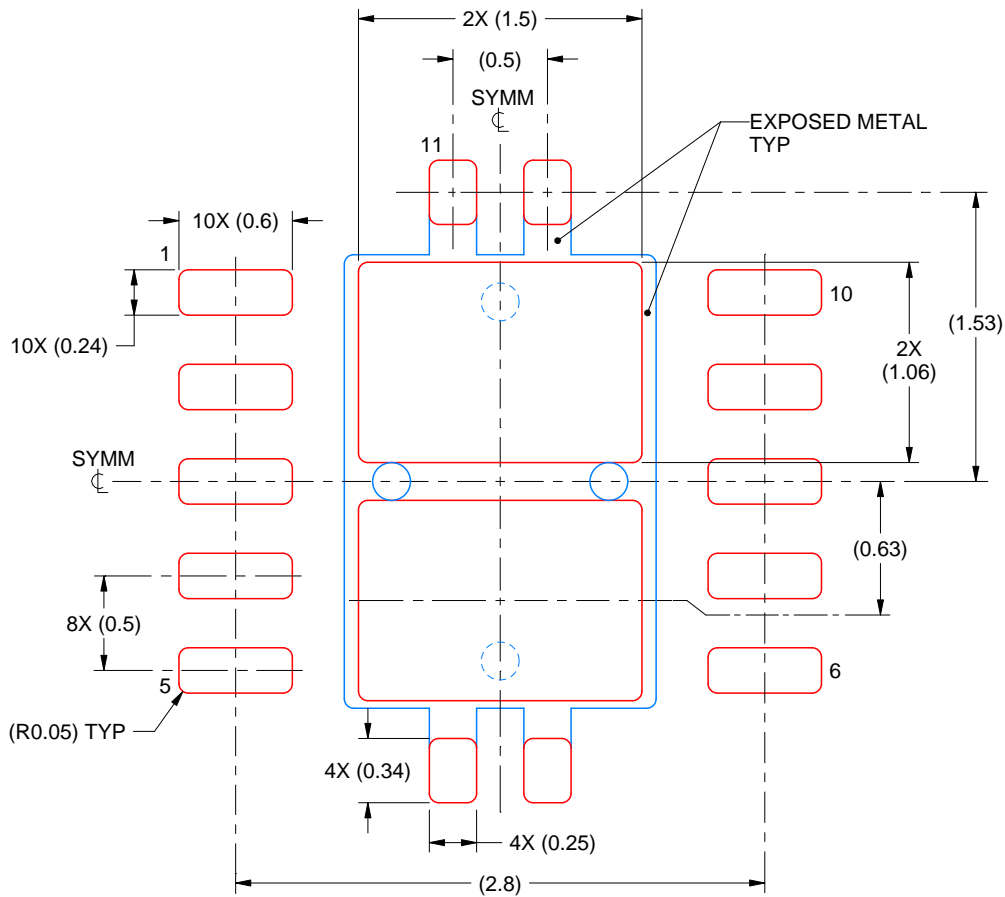

SOLDER PASTE EXAMPLE  
BASED ON 0.125 mm THICK STENCIL

EXPOSED PAD 11:  
80% PRINTED SOLDER COVERAGE BY AREA  
SCALE:25X

4218878/B 07/2018

NOTES: (continued)

6. Laser cutting apertures with trapezoidal walls and rounded corners may offer better paste release. IPC-7525 may have alternate design recommendations.

## IMPORTANT NOTICE AND DISCLAIMER

TI PROVIDES TECHNICAL AND RELIABILITY DATA (INCLUDING DATASHEETS), DESIGN RESOURCES (INCLUDING REFERENCE DESIGNS), APPLICATION OR OTHER DESIGN ADVICE, WEB TOOLS, SAFETY INFORMATION, AND OTHER RESOURCES "AS IS" AND WITH ALL FAULTS, AND DISCLAIMS ALL WARRANTIES, EXPRESS AND IMPLIED, INCLUDING WITHOUT LIMITATION ANY IMPLIED WARRANTIES OF MERCHANTABILITY, FITNESS FOR A PARTICULAR PURPOSE OR NON-INFRINGEMENT OF THIRD PARTY INTELLECTUAL PROPERTY RIGHTS.

These resources are intended for skilled developers designing with TI products. You are solely responsible for (1) selecting the appropriate TI products for your application, (2) designing, validating and testing your application, and (3) ensuring your application meets applicable standards, and any other safety, security, or other requirements. These resources are subject to change without notice. TI grants you permission to use these resources only for development of an application that uses the TI products described in the resource. Other reproduction and display of these resources is prohibited. No license is granted to any other TI intellectual property right or to any third party intellectual property right. TI disclaims responsibility for, and you will fully indemnify TI and its representatives against, any claims, damages, costs, losses, and liabilities arising out of your use of these resources.

TI's products are provided subject to TI's Terms of Sale ([www.ti.com/legal/termsofsale.html](http://www.ti.com/legal/termsofsale.html)) or other applicable terms available either on [ti.com](http://ti.com) or provided in conjunction with such TI products. TI's provision of these resources does not expand or otherwise alter TI's applicable warranties or warranty disclaimers for TI products.

Mailing Address: Texas Instruments, Post Office Box 655303, Dallas, Texas 75265  
Copyright © 2019, Texas Instruments Incorporated

## Looking for pricing, stock, or lifecycle information?

Click below to explore more details on WIN SOURCE:

 [View TPS40192DRCTG4 on WIN SOURCE](#)

 [Texas Instruments](#) Information

## Optimize Your Supply Chain with WIN SOURCE Solutions

-  Global Sourcing Solution
-  Obsolete Management
-  Cost Control Management
-  Shortage Management
-  Alternative Solution
-  Excess Inventory Management