



**THE DATASHEET OF
ICM7555IBAT**



ICM7555, ICM7556

General Purpose Timers

FN2867
Rev 1.00
June 28, 2016

The [ICM7555](#) and [ICM7556](#) are CMOS RC timers providing significantly improved performance over the standard SE/NE 555/556 and 355 timers, while at the same time being direct replacements for those devices in most applications. Improved parameters include low supply current, wide operating supply voltage range, low Threshold, Trigger and Reset currents, no crowbaring of the supply current during output transitions, higher frequency performance and no requirement to decouple Control Voltage for stable operation.

Specifically, the ICM7555 and ICM7556 are stable controllers capable of producing accurate time delays or frequencies. The ICM7556 is a dual ICM7555, with the two timers operating independently of each other, sharing only V+ and GND. In the one shot mode, the pulse width of each circuit is precisely controlled by one external resistor and capacitor. For astable operation as an oscillator, the free running frequency and the duty cycle are both accurately controlled by two external resistors and one capacitor. Unlike the regular bipolar SE/NE 555/556 devices, the Control Voltage terminal need not be decoupled with a capacitor. The circuits are triggered and reset on falling (negative) waveforms, and the output inverter can source or sink currents large enough to drive TTL loads, or provide minimal offsets to drive CMOS loads.

Features

- Exact equivalent in most cases for SE/NE 555/556 or TLC555/556
- Low supply current
 - ICM7555 60µA
 - ICM7556 120µA
- Extremely low input currents 20pA
- High speed operation 1MHz
- Guaranteed supply voltage range 2V to 18V
- Temperature stability 0.005%/°C at +25°C
- Normal reset function - no crowbaring of supply during output transition
- Can be used with higher impedance timing elements than regular 555/556 for longer RC time constants
- Timing from microseconds through hours
- Operates in both astable and monostable modes
- Adjustable duty cycle
- High output source/sink driver can drive TTL/CMOS
- Outputs have very low offsets, HIGH and LOW
- Pb-free (RoHS Compliant)

Applications

- Precision timing
- Pulse generation
- Sequential timing
- Time delay generation
- Pulse width modulation
- Pulse position modulation
- Missing pulse detector

Pin Configurations

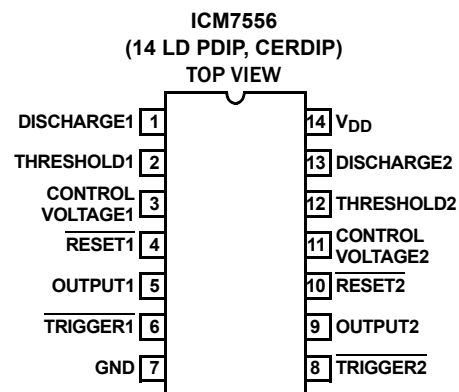
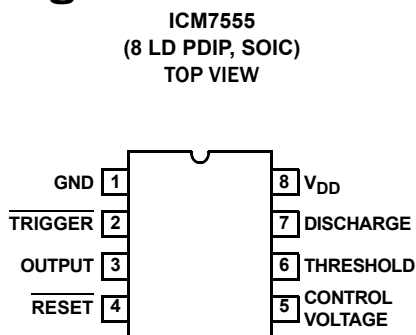

Ordering Information

PART NUMBER	PART MARKING	TEMP. RANGE (°C)	TAPE AND REEL (UNITS)	PACKAGE (RoHS COMPLIANT)	PKG. DWG. #
ICM7555CBAZ (Notes 2, 3)	7555 CBAZ	0 to +70		8 Ld SOIC	M8.15
ICM7555CBAZ-T (Notes 1, 2, 3)	7555 CBAZ	0 to +70	2.5k	8 Ld SOIC (Tape and Reel)	M8.15
ICM7555IBAZ (Notes 2, 3)	7555 IBAZ	-25 to +85		8 Ld SOIC	M8.15
ICM7555IBAZ-T (Notes 1, 2, 3)	7555 IBAZ	-25 to +85	2.5k	8 Ld SOIC (Tape and Reel)	M8.15
ICM7555IPAZ (Notes 2, 3)	7555 IPAZ	-25 to +85		8 Ld PDIP	E8.3
ICM7556IPDZ (Notes 2, 3)	ICM7556IPDZ	-25 to +85		14 Ld PDIP	E14.3
ICM7556MJD (No longer available or supported)	ICM7556MJD	-55 to +125		14 Ld Cerdip	F14.3

NOTES:

1. Please refer to [TB347](#) for details on reel specifications.
2. These Intersil Pb-free plastic packaged products employ special Pb-free material sets, molding compounds/die attach materials, and 100% matte tin plate plus anneal (e3 termination finish, which is RoHS compliant and compatible with both SnPb and Pb-free soldering operations). Intersil Pb-free products are MSL classified at Pb-free peak reflow temperatures that meet or exceed the Pb-free requirements of IPC/JEDEC J STD-020.
3. For Moisture Sensitivity Level (MSL), please see product information page for [ICM7555](#), [ICM7556](#). For more information on MSL, please see tech brief [TB363](#).

Absolute Maximum Ratings

Supply Voltage	+18V
Input Voltage	
Trigger, Control Voltage, Threshold, Reset (Note 4)	V+ +0.3V to GND -0.3V
Output Current	100mA

Operating Conditions

Temperature Range	
ICM7555C	0 °C to +70 °C
ICM7555I, ICM7556I	-25 °C to +85 °C
ICM7556M	-55 °C to +125 °C

Thermal Information

Thermal Resistance (Typical, Notes 5, 6)	θ_{JA} (°C/W)	θ_{JC} (°C/W)
14 Ld CERDIP Package	80	24
14 Ld PDIP Package*	115	46
8 Ld PDIP Package*	130	69
8 Ld SOIC Package	170	67
Maximum Junction Temperature (Hermetic Package)	+175 °C	
Maximum Junction Temperature (Plastic Package)	+150 °C	
Maximum Storage Temperature Range	-65 °C to +150 °C	
* Pb-free PDIPs can be used for through-hole wave solder processing only. They are not intended for use in Reflow solder processing applications.		

CAUTION: Do not operate at or near the maximum ratings listed for extended periods of time. Exposure to such conditions may adversely impact product reliability and result in failures not covered by warranty.

NOTES:

- Due to the SCR structure inherent in the CMOS process used to fabricate these devices, connecting any terminal to a voltage greater than V+ +0.3V or less than V- -0.3V may cause destructive latch-up. For this reason it is recommended that no inputs from external sources not operating from the same power supply be applied to the device before its power supply is established. In multiple supply systems, the supply of the ICM7555 and ICM7556 must be turned on first.
- θ_{JA} is measured with the component mounted on a low effective thermal conductivity test board in free air. See Tech Brief [TB379](#) for details.
- For θ_{JC} , the “case temp” location is taken at the package top center.

Electrical Specifications Applies to ICM7555 and ICM7556, unless otherwise specified.

PARAMETER	SYMBOL	TEST CONDITIONS	$T_A = +25\text{ °C}$			(Note 8) $-55\text{ °C TO }+125\text{ °C}$			UNIT
			MIN	TYP	MAX	MIN	TYP	MAX	
Static Supply Current	I_{DD}	ICM7555 $V_{DD} = 5V$		40	200			300	μA
			$V_{DD} = 15V$		60	300			300
		ICM7556 $V_{DD} = 5V$		80	400			600	μA
			$V_{DD} = 15V$		120	600			600
Monostable Timing Accuracy		$R_A = 10k, C = 0.1\mu F, V_{DD} = 5V$		2					%
						858		1161	μs
Drift with Temperature (Note 7)		$V_{DD} = 5V$					150		ppm/°C
		$V_{DD} = 10V$					200		ppm/°C
		$V_{DD} = 15V$					250		ppm/°C
Drift with Supply (Note 7)		$V_{DD} = 5V$ to $15V$		0.5			0.5		%/V
Astable Timing Accuracy		$R_A = R_B = 10k, C = 0.1\mu F, V_{DD} = 5V$		2					%
						1717		2323	μs
Drift with Temperature (Note 7)		$V_{DD} = 5V$					150		ppm/°C
		$V_{DD} = 10V$					200		ppm/°C
		$V_{DD} = 15V$					250		ppm/°C
Drift with Supply (Note 7)		$V_{DD} = 5V$ to $15V$		0.5			0.5		%/V
Threshold Voltage	V_{TH}	$V_{DD} = 15V$	62	67	71	61		72	% V_{DD}
Trigger Voltage	V_{TRIG}	$V_{DD} = 15V$	28	32	36	27		37	% V_{DD}
Trigger Current	I_{TRIG}	$V_{DD} = 15V$			10			50	nA
Threshold Current	I_{TH}	$V_{DD} = 15V$			10			50	nA
Control Voltage	V_{CV}	$V_{DD} = 15V$	62	67	71	61		72	% V_{DD}

Electrical Specifications Applies to ICM7555 and ICM7556, unless otherwise specified. (Continued)

PARAMETER	SYMBOL	TEST CONDITIONS	T _A = +25°C			(Note 8) -55°C TO +125°C			UNIT
			MIN	TYP	MAX	MIN	TYP	MAX	
Reset Voltage	V _{RST}	V _{DD} = 2V to 15V	0.4		1.0	0.2		1.2	V
Reset Current	I _{RST}	V _{DD} = 15V			10			50	nA
Discharge Leakage	I _{DIS}	V _{DD} = 15V			10			50	nA
Output Voltage	V _{OL}	V _{DD} = 15V, I _{SINK} = 20mA		0.4	1.0			1.25	V
		V _{DD} = 5V, I _{SINK} = 3.2mA		0.2	0.4			0.5	V
	V _{OH}	V _{DD} = 15V, I _{SOURCE} = 0.8mA	14.3	14.6		14.2			V
		V _{DD} = 5V, I _{SOURCE} = 0.8mA	4.0	4.3		3.8			V
Discharge Output Voltage	V _{DIS}	V _{DD} = 5V, I _{SINK} = 15mA		0.2	0.4			0.6	V
		V _{DD} = 15V, I _{SINK} = 15mA						0.4	V
Supply Voltage (Note 7)	V _{DD}	Functional Operation	2.0		18.0	3.0		16.0	V
Output Rise Time (Note 7)	t _R	R _L = 10M, C _L = 10pF, V _{DD} = 5V		75					ns
Output Fall Time (Note 7)	t _F	R _L = 10M, C _L = 10pF, V _{DD} = 5V		75					ns
Oscillator Frequency (Note 7)	f _{MAX}	V _{DD} = 5V, R _A = 470Ω, R _B = 270Ω, C = 200pF		1					MHz

NOTES:

- 7. These parameters are based upon characterization data and are not tested.
- 8. Applies only to military temperature range product (M suffix).

Functional Diagram

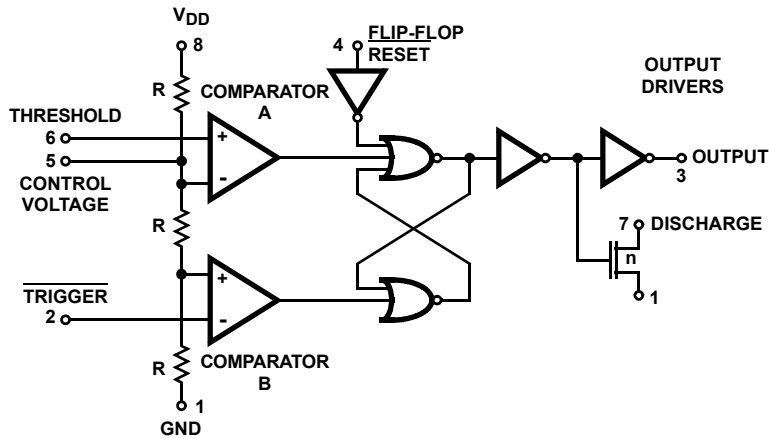

NOTE: This functional diagram reduces the circuitry down to its simplest equivalent components. Tie down unused inputs.

FIGURE 1. FUNCTIONAL DIAGRAM

TRUTH TABLE

THRESHOLD VOLTAGE	TRIGGER VOLTAGE	RESET	OUTPUT	DISCHARGE SWITCH
Don't Care	Don't Care	Low	Low	On
> ² / ₃ (V ⁺)	> ¹ / ₃ (V ⁺)	High	Low	On
< ² / ₃ (V ⁺)	> ¹ / ₃ (V ⁺)	High	Stable	Stable
Don't Care	< ¹ / ₃ (V ⁺)	High	High	Off

NOTE: RESET will dominate all other inputs: TRIGGER will dominate over THRESHOLD.

Schematic Diagram

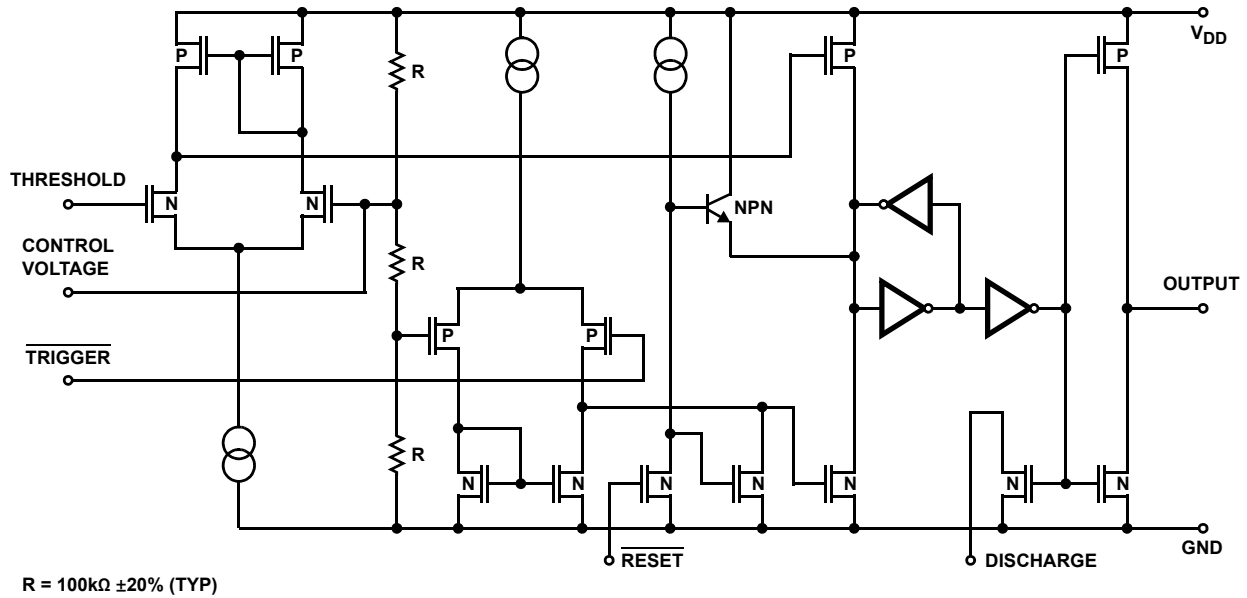

FIGURE 2. SCHEMATIC DIAGRAM

Application Information

General

The ICM7555 and ICM7556 devices are, in most instances, direct replacements for the SE/NE 555/556 devices. However, it is possible to effect economies in the external component count using the ICM7555 and ICM7556. Because the bipolar SE/NE 555/556 devices produce large crowbar currents in the output driver, it is necessary to decouple the power supply lines with a good capacitor close to the device. The ICM7555 and ICM7556 devices produce no such transients (see [Figure 3](#)).

The ICM7555 and ICM7556 produce supply current spikes of only 2mA to 3mA instead of 300mA to 400mA and supply decoupling is normally not necessary. Also, in most instances, the Control Voltage decoupling capacitors are not required since the input impedance of the CMOS comparators on chip are very high. Thus, for many applications, two capacitors can be saved using an ICM7555 and three capacitors with an ICM7556.

POWER SUPPLY CONSIDERATIONS

Although the supply current consumed by the ICM7555 and ICM7556 devices is very low, the total system supply current can be high unless the timing components are high impedance. Therefore, use high values for R and low values for C in [Figures 4](#), [5](#), and [6](#).

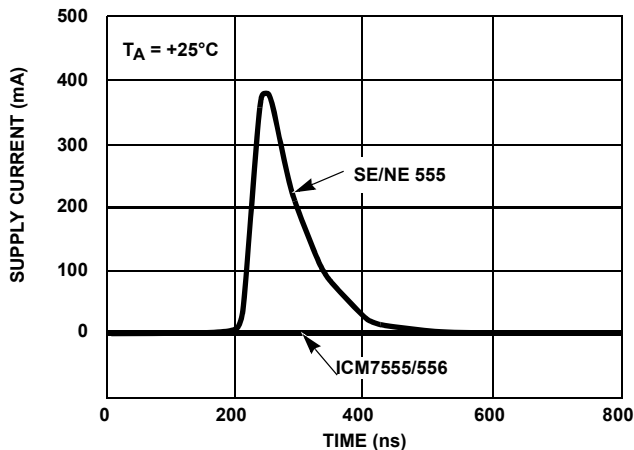

FIGURE 3. SUPPLY CURRENT TRANSIENT COMPARED WITH A STANDARD BIPOLAR 555 DURING AN OUTPUT TRANSITION

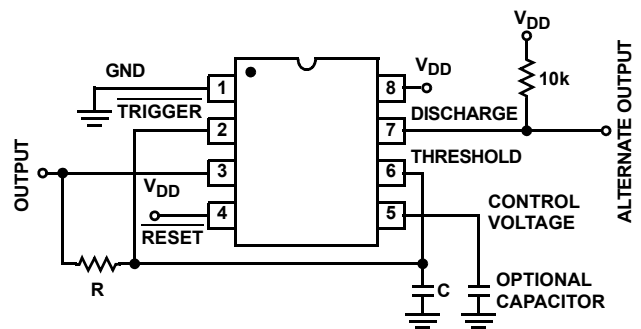

FIGURE 4. ASTABLE OPERATION

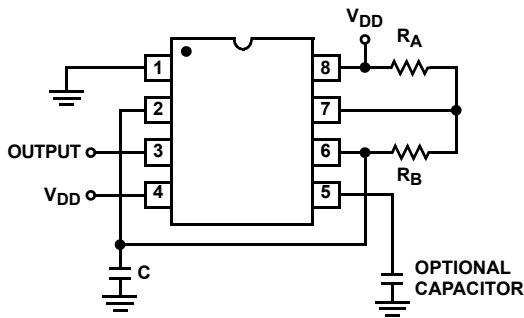

FIGURE 5. ALTERNATE ASTABLE CONFIGURATION

OUTPUT DRIVE CAPABILITY

The output driver consists of a CMOS inverter capable of driving most logic families including CMOS and TTL. As such, if driving CMOS, the output swing at all supply voltages will equal the supply voltage. At a supply voltage of 4.5V or more, the ICM7555 and ICM7556 will drive at least two standard TTL loads.

ASTABLE OPERATION

The circuit can be connected to trigger itself and free run as a multivibrator, see Figure 4. The output swings from rail-to-rail, and is a true 50% duty cycle square wave. Trip points and output swings are symmetrical. Less than a 1% frequency variation is observed over a voltage range of +5V to +15V.

$$f = \frac{1}{1.4 RC} \tag{EQ. 1}$$

The timer can also be connected as shown in Figure 5. In this circuit, the frequency is as shown by Equation 2:

$$f = 1.44 / (R_A + 2R_B)C \tag{EQ. 2}$$

The duty cycle is controlled by the values of RA and RB, by Equation 3:

$$D = (R_A + R_B) / (R_A + 2R_B) \tag{EQ. 3}$$

MONOSTABLE OPERATION

In this mode of operation, the timer functions as a one-shot (see Figure 6). Initially the external capacitor (C) is held discharged by a transistor inside the timer. Upon application of a negative Trigger pulse to pin 2, the internal flip-flop is set, which releases the short-circuit across the external capacitor and drives the Output high. The voltage across the capacitor now increases exponentially with a time constant $t = R_A C$. When the voltage across the capacitor equals $\frac{2}{3} V+$, the comparator resets the flip-flop, which in turn discharges the capacitor rapidly and also drives the OUTPUT to its low state. Trigger must return to a high state before the OUTPUT can return to a low state.

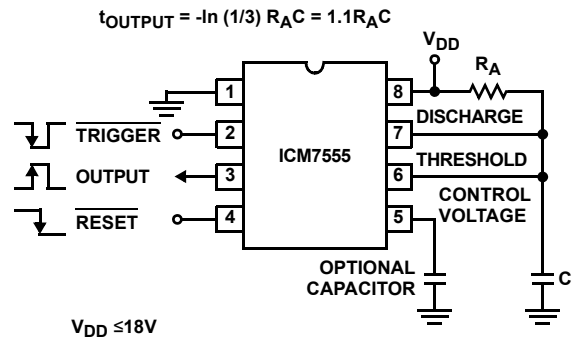

FIGURE 6. MONOSTABLE OPERATION

CONTROL VOLTAGE

The Control Voltage terminal permits the two trip voltages for the Threshold and Trigger internal comparators to be controlled. This provides the possibility of oscillation frequency modulation in the astable mode or even inhibition of oscillation, depending on the applied voltage. In the monostable mode, delay times can be changed by varying the applied voltage to the Control Voltage pin.

RESET

The Reset terminal is designed to have essentially the same trip voltage as the standard bipolar 555/556, i.e., 0.6V to 0.7V. At all supply voltages it represents an extremely high input impedance. The mode of operation of the Reset function is, however, much improved over the standard bipolar SE/NE 555/556 in that it controls only the internal flip-flop, which in turn controls simultaneously the state of the Output and Discharge pins. This avoids the multiple threshold problems sometimes encountered with slow falling edges in the bipolar devices.

Typical Performance Curves

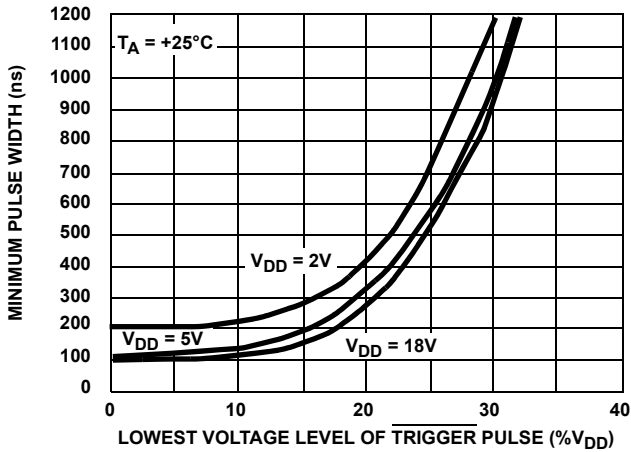

FIGURE 7. MINIMUM PULSE WIDTH REQUIRED FOR TRIGGERING

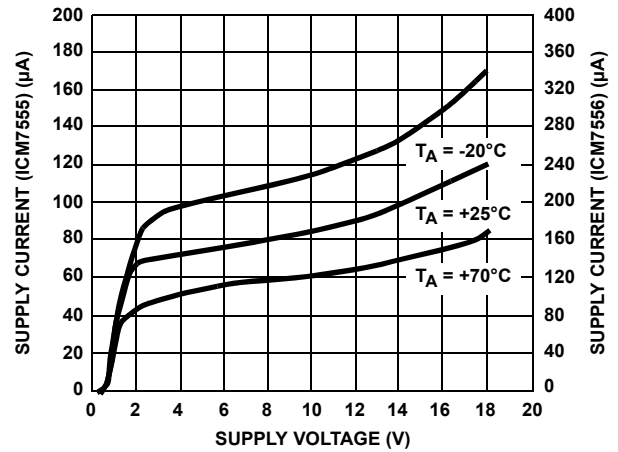

FIGURE 8. SUPPLY CURRENT vs SUPPLY VOLTAGE

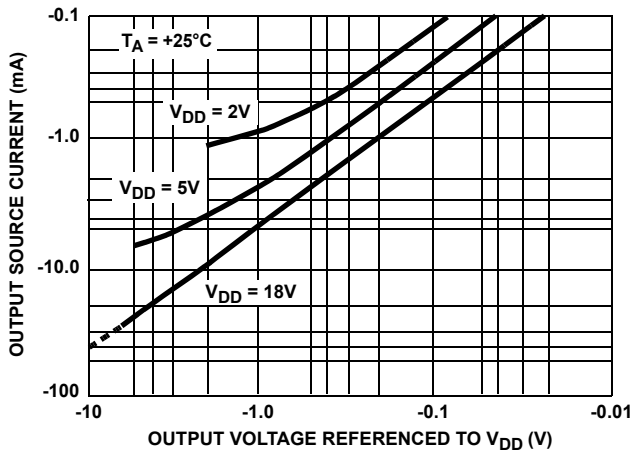

FIGURE 9. OUTPUT SOURCE CURRENT vs OUTPUT VOLTAGE

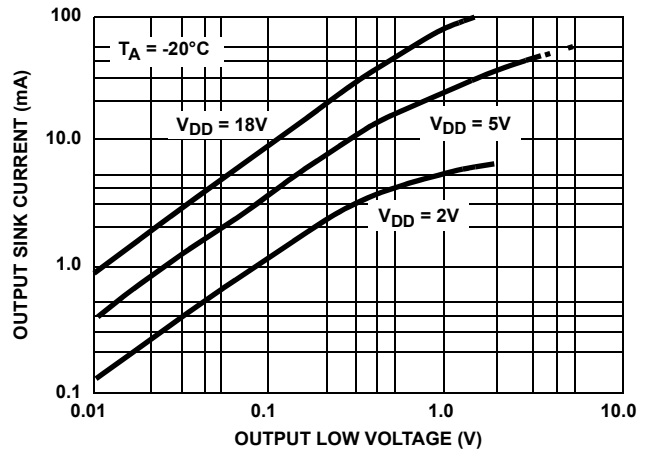

FIGURE 10. OUTPUT SINK CURRENT vs OUTPUT VOLTAGE

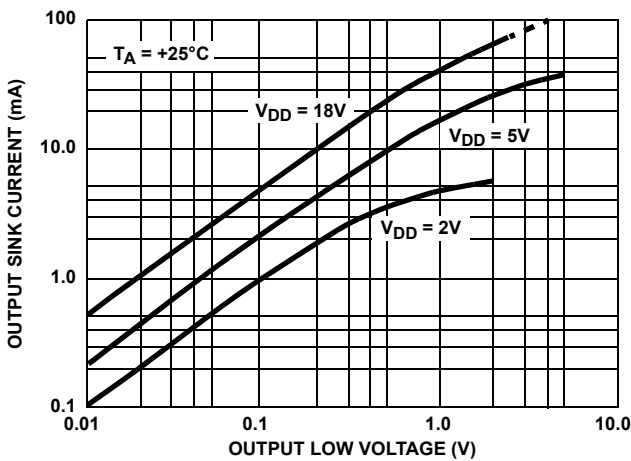

FIGURE 11. OUTPUT SINK CURRENT vs OUTPUT VOLTAGE

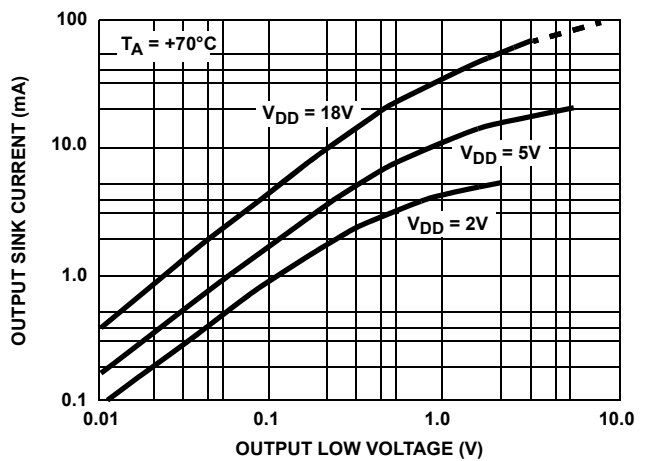

FIGURE 12. OUTPUT SINK CURRENT vs OUTPUT VOLTAGE

Typical Performance Curves (Continued)

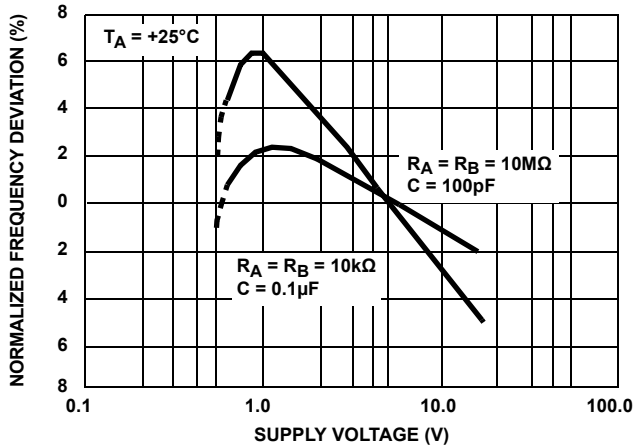

FIGURE 13. NORMALIZED FREQUENCY STABILITY IN THE ASTABLE MODE vs SUPPLY VOLTAGE

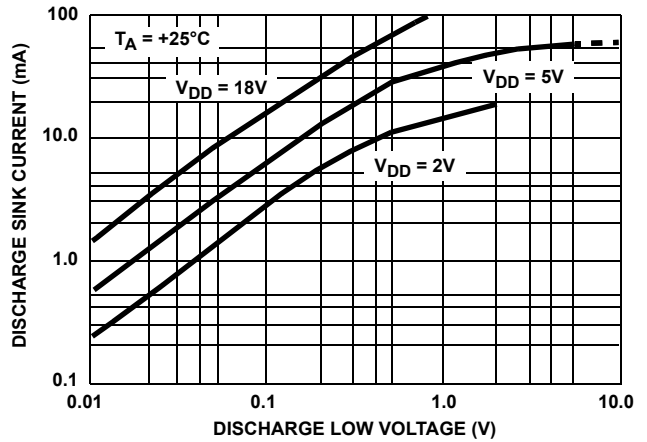

FIGURE 14. DISCHARGE OUTPUT CURRENT vs DISCHARGE OUTPUT VOLTAGE

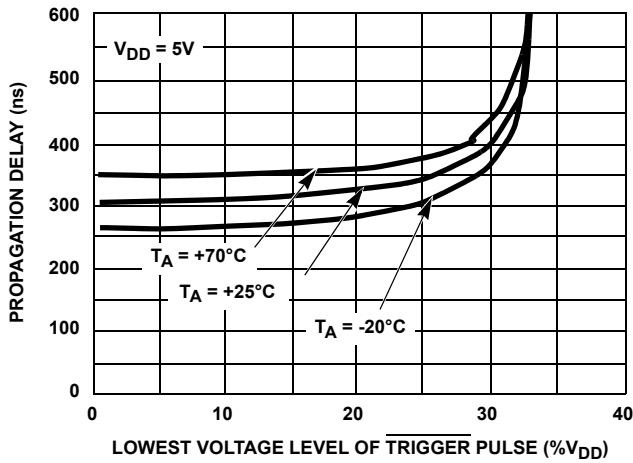

FIGURE 15. PROPAGATION DELAY vs VOLTAGE LEVEL OF TRIGGER PULSE

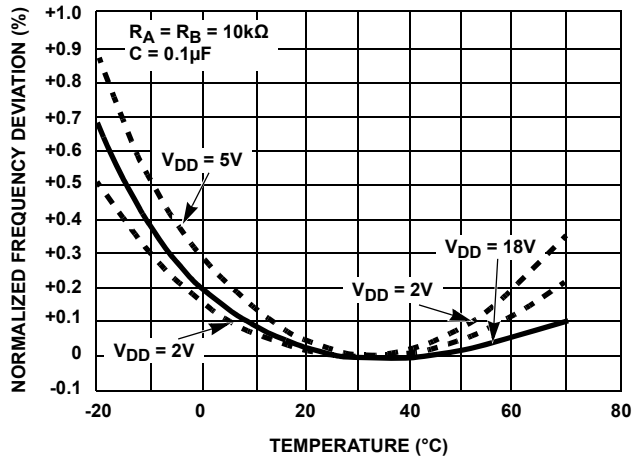

FIGURE 16. NORMALIZED FREQUENCY STABILITY IN THE ASTABLE MODE vs TEMPERATURE

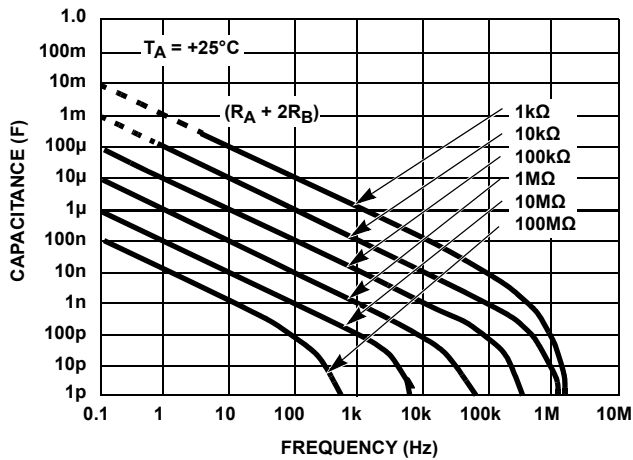

FIGURE 17. FREE RUNNING FREQUENCY vs R_A , R_B AND C

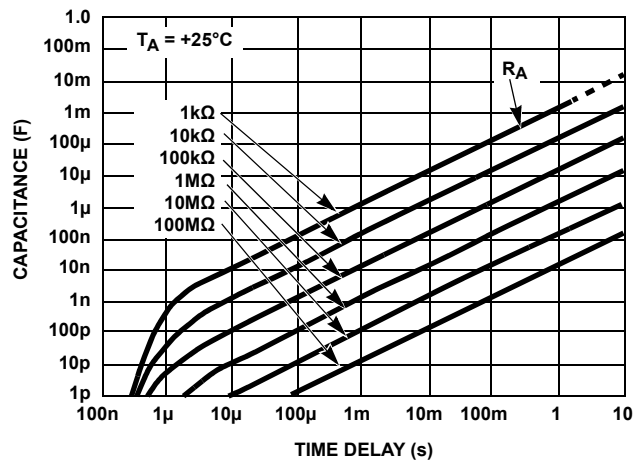

FIGURE 18. TIME DELAY IN THE MONOSTABLE MODE vs R_A AND C

Revision History The revision history provided is for informational purposes only and is believed to be accurate, but not warranted. Please go to the web to make sure that you have the latest revision.

DATE	REVISION	CHANGE
June 28, 2016	FN2867.10	Converted to new datasheet template. Updated 14 Ld PDIP "Pin Configuration" on page 1 by adding "1" or "2" to pins that have same name. Updated "Thermal Information" on page 3 by removing Maximum Lead Temperature and Adding T _{JC} values with corresponding note. Updated "Ordering Information" table on page 2 by removing obsoleted parts, adding Tape and Reel option column, adding MSL note and numbering notes accordingly. Updated POD M8.15 to most current version. POD changes are as follows: Changed in Typical Recommended Land Pattern the following: 2.41(0.095) to 2.20(0.087) 0.76 (0.030) to 0.60(0.023) 0.200 to 5.20(0.205) Updated to new POD format by removing table and moving dimensions onto drawing and adding land pattern

About Intersil

Intersil Corporation is a leading provider of innovative power management and precision analog solutions. The company's products address some of the largest markets within the industrial and infrastructure, mobile computing and high-end consumer markets. For the most updated datasheet, application notes, related documentation and related parts, please see the respective product information page found at www.intersil.com. You may report errors or suggestions for improving this datasheet by visiting www.intersil.com/ask. Reliability reports are also available from our website at www.intersil.com/support.

© Copyright Intersil Americas LLC 1997-2016. All Rights Reserved.
 All trademarks and registered trademarks are the property of their respective owners.

For additional products, see www.intersil.com/en/products.html

Intersil products are manufactured, assembled and tested utilizing ISO9001 quality systems as noted in the quality certifications found at www.intersil.com/en/support/qualandreliability.html

Intersil products are sold by description only. Intersil may modify the circuit design and/or specifications of products at any time without notice, provided that such modification does not, in Intersil's sole judgment, affect the form, fit or function of the product. Accordingly, the reader is cautioned to verify that datasheets are current before placing orders. Information furnished by Intersil is believed to be accurate and reliable. However, no responsibility is assumed by Intersil or its subsidiaries for its use; nor for any infringements of patents or other rights of third parties which may result from its use. No license is granted by implication or otherwise under any patent or patent rights of Intersil or its subsidiaries.

For information regarding Intersil Corporation and its products, see www.intersil.com

Package Outline Drawing

M8.15

8 LEAD NARROW BODY SMALL OUTLINE PLASTIC PACKAGE

Rev 4, 1/12

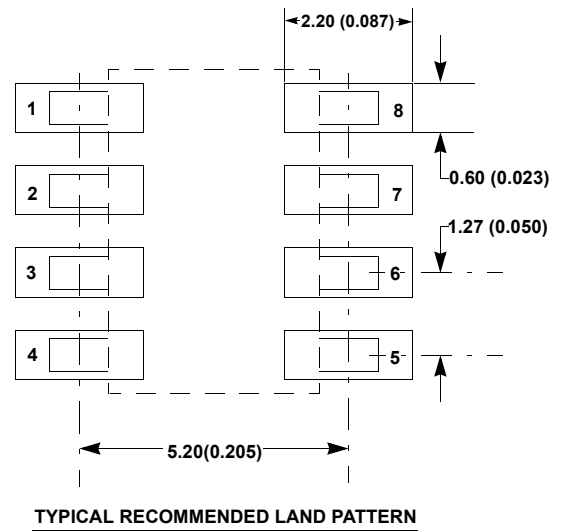
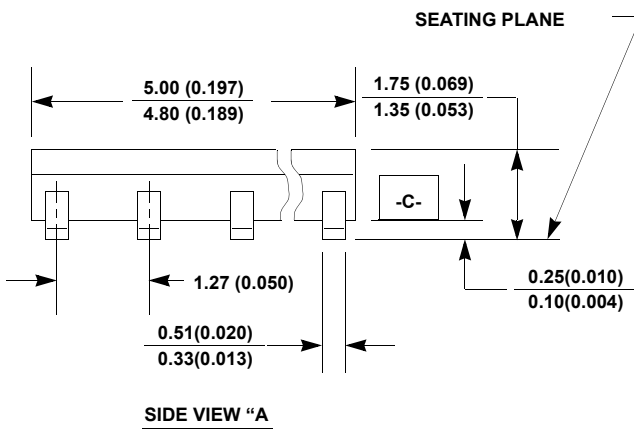
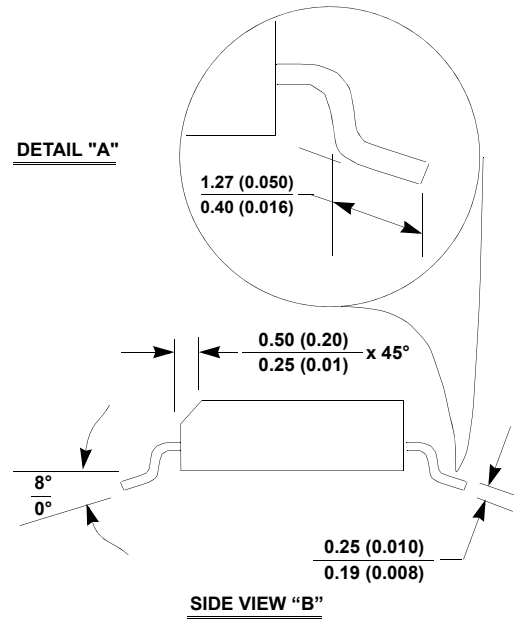
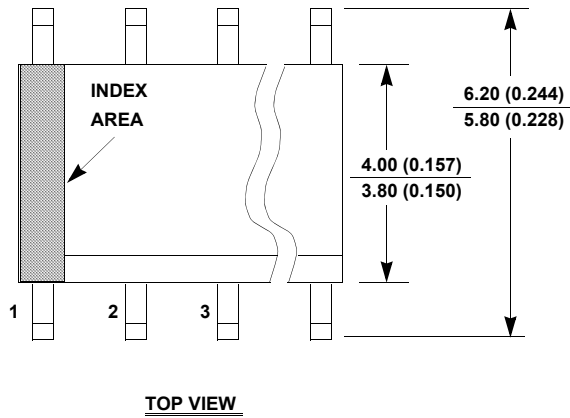

NOTES:

1. Dimensioning and tolerancing per ANSI Y14.5M-1994.
2. Package length does not include mold flash, protrusions or gate burrs. Mold flash, protrusion and gate burrs shall not exceed 0.15mm (0.006 inch) per side.
3. Package width does not include interlead flash or protrusions. Interlead flash and protrusions shall not exceed 0.25mm (0.010 inch) per side.
4. The chamfer on the body is optional. If it is not present, a visual index feature must be located within the crosshatched area.
5. Terminal numbers are shown for reference only.
6. The lead width as measured 0.36mm (0.014 inch) or greater above the seating plane, shall not exceed a maximum value of 0.61mm (0.024 inch).
7. Controlling dimension: MILLIMETER. Converted inch dimensions are not necessarily exact.
8. This outline conforms to JEDEC publication MS-012-AA ISSUE C.

Dual-In-Line Plastic Packages (PDIP)

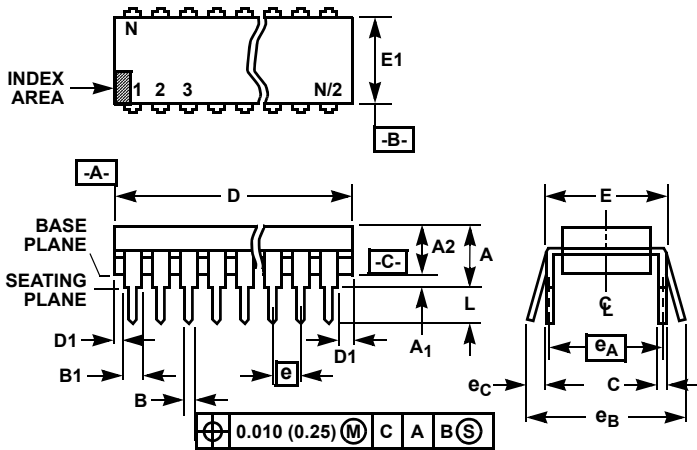

E8.3 (JEDEC MS-001-BA ISSUE D) 8 LEAD DUAL-IN-LINE PLASTIC PACKAGE

SYMBOL	INCHES		MILLIMETERS		NOTES
	MIN	MAX	MIN	MAX	
A	-	0.210	-	5.33	4
A1	0.015	-	0.39	-	4
A2	0.115	0.195	2.93	4.95	-
B	0.014	0.022	0.356	0.558	-
B1	0.045	0.070	1.15	1.77	8, 10
C	0.008	0.014	0.204	0.355	-
D	0.355	0.400	9.01	10.16	5
D1	0.005	-	0.13	-	5
E	0.300	0.325	7.62	8.25	6
E1	0.240	0.280	6.10	7.11	5
e	0.100 BSC		2.54 BSC		-
eA	0.300 BSC		7.62 BSC		6
eB	-	0.430	-	10.92	7
L	0.115	0.150	2.93	3.81	4
N	8		8		9

NOTES:

- Controlling Dimensions: INCH. In case of conflict between English and Metric dimensions, the inch dimensions control.
- Dimensioning and tolerancing per ANSI Y14.5M-1982.
- Symbols are defined in the "MO Series Symbol List" in Section 2.2 of Publication No. 95.
- Dimensions A, A1 and L are measured with the package seated in JEDEC seating plane gauge GS-3.
- D, D1, and E1 dimensions do not include mold flash or protrusions. Mold flash or protrusions shall not exceed 0.010 inch (0.25mm).
- E and e_A are measured with the leads constrained to be perpendicular to datum $-C-$.
- e_B and e_C are measured at the lead tips with the leads unconstrained. e_C must be zero or greater.
- B1 maximum dimensions do not include dambar protrusions. Dambar protrusions shall not exceed 0.010 inch (0.25mm).
- N is the maximum number of terminal positions.
- Corner leads (1, N, N/2 and N/2 + 1) for E8.3, E16.3, E18.3, E28.3, E42.6 will have a B1 dimension of 0.030 - 0.045 inch (0.76 - 1.14mm).

Rev. 0 12/93

Dual-In-Line Plastic Packages (PDIP)

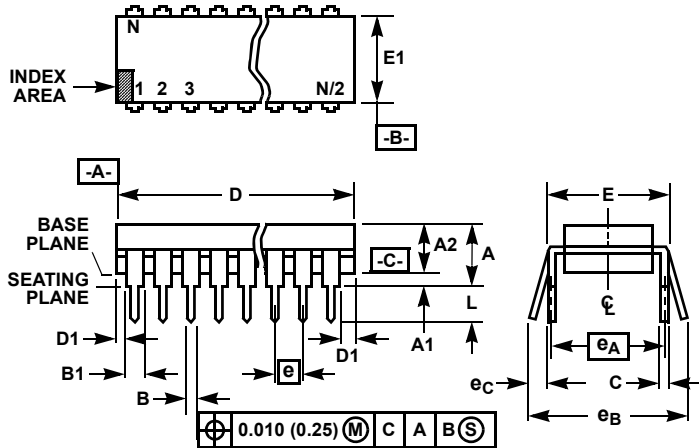

E14.3 (JEDEC MS-001-AA ISSUE D)

14 LEAD DUAL-IN-LINE PLASTIC PACKAGE

SYMBOL	INCHES		MILLIMETERS		NOTES
	MIN	MAX	MIN	MAX	
A	-	0.210	-	5.33	4
A1	0.015	-	0.39	-	4
A2	0.115	0.195	2.93	4.95	-
B	0.014	0.022	0.356	0.558	-
B1	0.045	0.070	1.15	1.77	8
C	0.008	0.014	0.204	0.355	-
D	0.735	0.775	18.66	19.68	5
D1	0.005	-	0.13	-	5
E	0.300	0.325	7.62	8.25	6
E1	0.240	0.280	6.10	7.11	5
e	0.100 BSC		2.54 BSC		-
e _A	0.300 BSC		7.62 BSC		6
e _B	-	0.430	-	10.92	7
L	0.115	0.150	2.93	3.81	4
N	14		14		9

Rev. 0 12/93

NOTES:

- Controlling Dimensions: INCH. In case of conflict between English and Metric dimensions, the inch dimensions control.
- Dimensioning and tolerancing per ANSI Y14.5M-1982.
- Symbols are defined in the "MO Series Symbol List" in Section 2.2 of Publication No. 95.
- Dimensions A, A1 and L are measured with the package seated in JEDEC seating plane gauge GS-3.
- D, D1, and E1 dimensions do not include mold flash or protrusions. Mold flash or protrusions shall not exceed 0.010 inch (0.25mm).
- E and e_A are measured with the leads constrained to be perpendicular to datum -C-.
- e_B and e_C are measured at the lead tips with the leads unconstrained. e_C must be zero or greater.
- B1 maximum dimensions do not include dambar protrusions. Dambar protrusions shall not exceed 0.010 inch (0.25mm).
- N is the maximum number of terminal positions.
- Corner leads (1, N, N/2 and N/2 + 1) for E8.3, E16.3, E18.3, E28.3, E42.6 will have a B1 dimension of 0.030 - 0.045 inch (0.76 - 1.14mm).

Ceramic Dual-In-Line Frit Seal Packages (CERDIP)

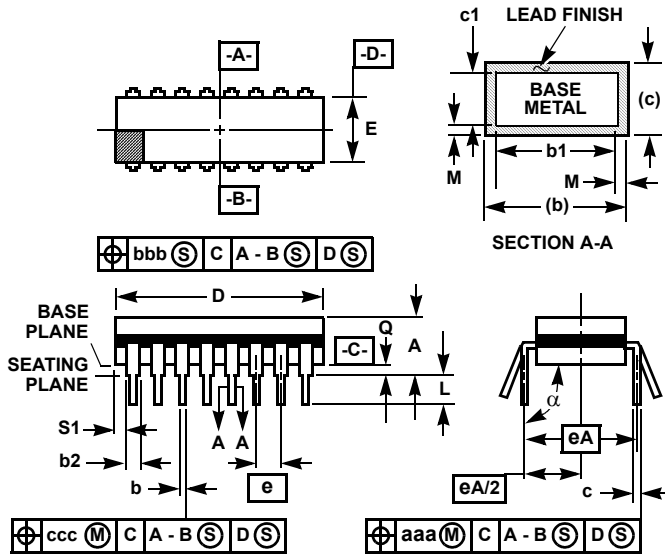

NOTES:

1. Index area: A notch or a pin one identification mark shall be located adjacent to pin one and shall be located within the shaded area shown. The manufacturer's identification shall not be used as a pin one identification mark.
2. The maximum limits of lead dimensions b and c or M shall be measured at the centroid of the finished lead surfaces, when solder dip or tin plate lead finish is applied.
3. Dimensions b1 and c1 apply to lead base metal only. Dimension M applies to lead plating and finish thickness.
4. Corner leads (1, N, N/2, and N/2+1) may be configured with a partial lead paddle. For this configuration dimension b3 replaces dimension b2.
5. This dimension allows for off-center lid, meniscus, and glass overrun.
6. Dimension Q shall be measured from the seating plane to the base plane.
7. Measure dimension S1 at all four corners.
8. N is the maximum number of terminal positions.
9. Dimensioning and tolerancing per ANSI Y14.5M - 1982.
10. Controlling dimension: INCH.

F14.3 (MIL-STD-1835 GDIP1-T14 (D-1, CONFIGURATION A))
14 LEAD CERAMIC DUAL-IN-LINE FRIT SEAL PACKAGE

SYMBOL	INCHES		MILLIMETERS		NOTES
	MIN	MAX	MIN	MAX	
A	-	0.200	-	5.08	-
b	0.014	0.026	0.36	0.66	2
b1	0.014	0.023	0.36	0.58	3
b2	0.045	0.065	1.14	1.65	-
b3	0.023	0.045	0.58	1.14	4
c	0.008	0.018	0.20	0.46	2
c1	0.008	0.015	0.20	0.38	3
D	-	0.785	-	19.94	5
E	0.220	0.310	5.59	7.87	5
e	0.100 BSC		2.54 BSC		-
eA	0.300 BSC		7.62 BSC		-
eA/2	0.150 BSC		3.81 BSC		-
L	0.125	0.200	3.18	5.08	-
Q	0.015	0.060	0.38	1.52	6
S1	0.005	-	0.13	-	7
α	90 ⁰	105 ⁰	90 ⁰	105 ⁰	-
aaa	-	0.015	-	0.38	-
bbb	-	0.030	-	0.76	-
ccc	-	0.010	-	0.25	-
M	-	0.0015	-	0.038	2, 3
N	14		14		8

Rev. 0 4/94

Looking for pricing, stock, or lifecycle information?

Click below to explore more details on WIN SOURCE:

 [View ICM7555IBAT on WIN SOURCE](#)

 [Intersil Information](#)

Optimize Your Supply Chain with WIN SOURCE Solutions

-  Global Sourcing Solution
-  Obsolete Management
-  Cost Control Management
-  Shortage Management
-  Alternative Solution
-  Excess Inventory Management