



**THE DATASHEET OF
CAT8801MTB-GT3**



CAT8801

200 nA Microprocessor Power Supply Supervisors

Description

The CAT8801 is a supervisory circuit that monitors power supplies in digital systems and provides a reset signal whenever the system's input voltage is below a prescribed minimum level. The CAT8801 replaces popular voltage supervisors such as MAX809 in applications where operating current is a primary consideration.

CAT8801 generates a reset signal, which is asserted while the power supply voltage is below a preset threshold level and remains asserted for at least 140 ms after the power supply level has risen above that level. Nine industry standard threshold levels are offered to support +5.0 V, +3.3 V, +3.0 V, +2.5 V and +1.8 V systems. ON Semiconductor's floating gate technology, used in programming the trigger thresholds, makes it possible to quickly offer any custom reset threshold value should the 9 standard voltage thresholds not meet a system's needs.

The CAT8801 features a Push-Pull CMOS $\overline{\text{RESET}}$ output (active LOW) and is fully specified over the industrial temperature range of -40°C to 85°C .

CAT8801 is available in compact 3-pin SOT23 and SC-70 packages.

Features

- Precision Voltage Monitoring of +1.8 V, +2.5 V, +3.0 V, +3.3 V and +5.0 V Power Supplies
- Ultra Low 200 nA Supply Current
- $\pm 1.2\%$ Voltage Threshold Accuracy
- 270 ms Power-On Reset Timeout
- Reset Signal Valid Down to $V_{CC} = 1\text{ V}$
- No External Components Necessary
- High Immunity to Power-Supply Transients
- Industrial Temperature Range: -40°C to $+85^{\circ}\text{C}$
- Available in RoHS-compliant SOT-23 and SC-70 Packages

Applications

- Computers
- Servers
- Laptops
- Cable Modems
- Wireless Communications
- Embedded Control Systems
- Power Meters
- PDAs and Handheld Equipment



ON Semiconductor®

<http://onsemi.com>

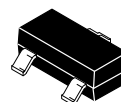

SOT-23
TB SUFFIX
CASE 527AG

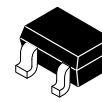

SC-70
SD SUFFIX
CASE 419AB

PIN CONNECTIONS

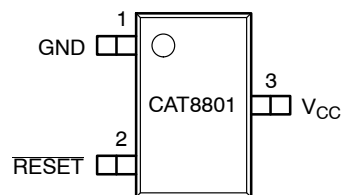

3-Lead SOT-23
3-Lead SC-70
(Top View)

THRESHOLD SUFFIX SELECTOR

Threshold Suffix	Nominal Threshold
L	4.625
M	4.380
T	3.075
S	2.925
R	2.630
Z	2.320
Y	2.190
W	1.670
V	1.580

ORDERING INFORMATION

See detailed ordering and shipping information in the package dimensions section on page 7 of this data sheet.

CAT8801

Table 1. PIN DESCRIPTION

Pin #	Name	Description
1	GND	Ground
2	RESET	Active LOW reset. RESET is asserted if V_{CC} falls below the reset threshold and remains low for at least 140 ms after V_{CC} rises above the reset threshold.
3	V_{CC}	Power supply voltage that is monitored.

Block Diagram

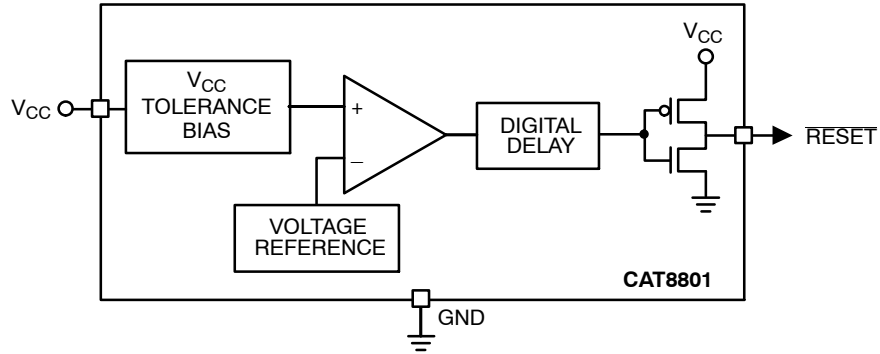

Table 2. ABSOLUTE MAXIMUM RATINGS

Parameters	Ratings	Units
Any pin with respect to ground	-0.3 to +6.0	V
Input Current, V_{CC}	20	mA
Output Current, RESET	20	mA
Rate of Rise, V_{CC}	100	V/ μ s
Continuous Power Dissipation		mW
Derate 2.2 mW/ $^{\circ}$ C above 70 $^{\circ}$ C (SC-70)	175	
Derate 4 mW/ $^{\circ}$ C above 70 $^{\circ}$ C (SOT-23)	320	
Operating Temperature Range	-40 to +85	$^{\circ}$ C
Storage Temperature Range	-65 to +150	$^{\circ}$ C
Lead Soldering Temperature (10 seconds)	300	$^{\circ}$ C

Stresses exceeding Maximum Ratings may damage the device. Maximum Ratings are stress ratings only. Functional operation above the Recommended Operating Conditions is not implied. Extended exposure to stresses above the Recommended Operating Conditions may affect device reliability.

CAT8801

Table 3. ELECTRICAL CHARACTERISTICS (Note 1)

(V_{CC} = Full range, T_A = -40°C to $+85^{\circ}\text{C}$ unless otherwise noted. Typical values at T_A = $+25^{\circ}\text{C}$.)

Symbol	Parameter	Test Conditions	Min	Typ	Max	Units	
	V_{CC} Range	$T_A = 0^{\circ}\text{C}$ to $+70^{\circ}\text{C}$	1.0		5.5	V	
		$T_A = -40^{\circ}\text{C}$ to $+85^{\circ}\text{C}$	1.2		5.5		
I_{CC}	Supply Current	$V_{TH} < V_{CC} < 5.5\text{ V}$		200	400	nA	
		$V_{TH} < V_{CC} < 3.6\text{ V}$		175	350		
V_{TH}	Reset Threshold Voltage (Note 2)	L	$T_A = +25^{\circ}\text{C}$	4.570	4.625	4.681	V
			$T_A = -40^{\circ}\text{C}$ to $+85^{\circ}\text{C}$	4.500		4.750	
		M	$T_A = +25^{\circ}\text{C}$	4.327	4.380	4.433	
			$T_A = -40^{\circ}\text{C}$ to $+85^{\circ}\text{C}$	4.262		4.498	
		T	$T_A = +25^{\circ}\text{C}$	3.038	3.075	3.112	
			$T_A = -40^{\circ}\text{C}$ to $+85^{\circ}\text{C}$	3.000		3.150	
		S	$T_A = +25^{\circ}\text{C}$	2.890	2.925	2.960	
			$T_A = -40^{\circ}\text{C}$ to $+85^{\circ}\text{C}$	2.850		3.000	
		R	$T_A = +25^{\circ}\text{C}$	2.598	2.630	2.662	
			$T_A = -40^{\circ}\text{C}$ to $+85^{\circ}\text{C}$	2.559		2.701	
		Z	$T_A = +25^{\circ}\text{C}$	2.292	2.320	2.348	
			$T_A = -40^{\circ}\text{C}$ to $+85^{\circ}\text{C}$	2.257		2.383	
		Y	$T_A = +25^{\circ}\text{C}$	2.164	2.190	2.216	
			$T_A = -40^{\circ}\text{C}$ to $+85^{\circ}\text{C}$	2.131		2.249	
		W	$T_A = +25^{\circ}\text{C}$	1.650	1.670	1.690	
			$T_A = -40^{\circ}\text{C}$ to $+85^{\circ}\text{C}$	1.625		1.715	
		V	$T_A = +25^{\circ}\text{C}$	1.561	1.580	1.599	
			$T_A = -40^{\circ}\text{C}$ to $+85^{\circ}\text{C}$	1.537		1.623	
V_{TH_HYS}	Threshold Hysteresis			2		%	
	Reset Threshold Temperature Coefficient				0.1	mV/ $^{\circ}\text{C}$	
	V_{CC} to Reset Delay	$V_{CC} = V_{TH}$ to $(V_{TH} - 100\text{ mV})$		20	50	μs	
	Reset Active Timeout Period	$T_A = -40^{\circ}\text{C}$ to $+85^{\circ}\text{C}$	140	270	460	ms	
V_{OL}	RESET Output Voltage Low	$I_{SINK} = 2\text{ mA}$			0.4	V	
V_{OH}	RESET Output Voltage High	$I_{SOURCE} = 0.5\text{ mA}$	$0.8 \times V_{CC}$			V	

1. Production testing done at $T_A = +25^{\circ}\text{C}$; limits over temperature guaranteed by design.
2. Measured on falling edge of V_{CC} .

CAT8801

TYPICAL OPERATING CHARACTERISTICS

(V_{CC} = Full range, T_A = -40°C to $+85^{\circ}\text{C}$ unless otherwise noted. Typical values at T_A = $+25^{\circ}\text{C}$.)

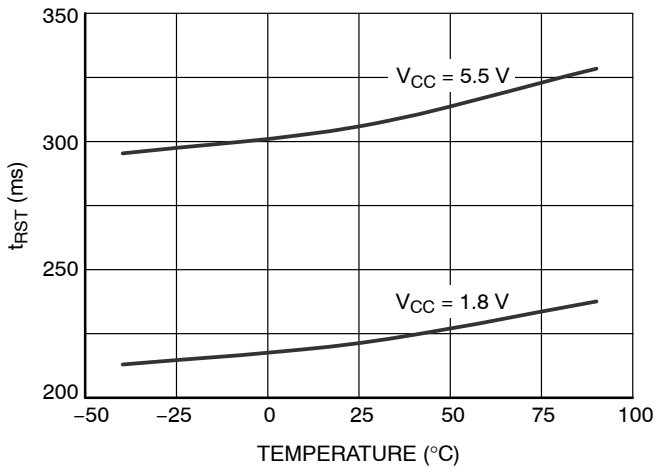

Figure 1. Power-Up Reset Timeout

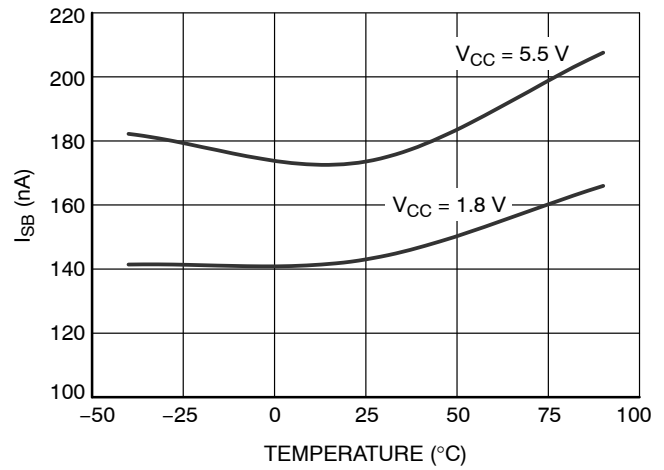

Figure 2. Supply Current vs. Temperature

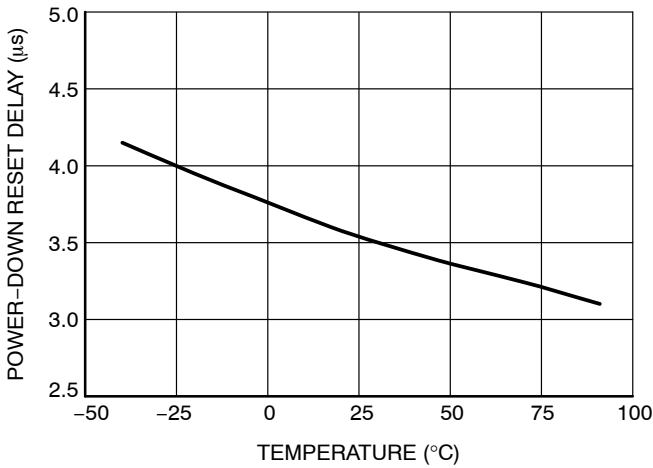

Figure 3. Power-Down Reset Delay vs. Temperature

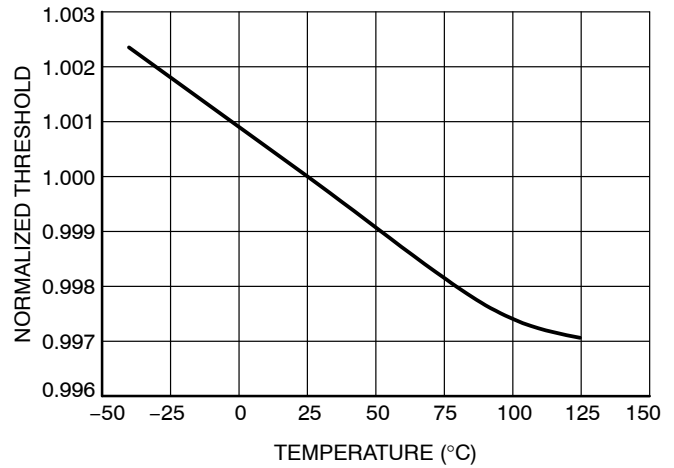

Figure 4. Normalized Reset Threshold vs. Temperature

Description

Reset Timing

The reset signal is asserted LOW for the CAT8801 when the power supply voltage falls below the threshold trip voltage and remains asserted for at least 140 ms after the power supply voltage has risen above the threshold.

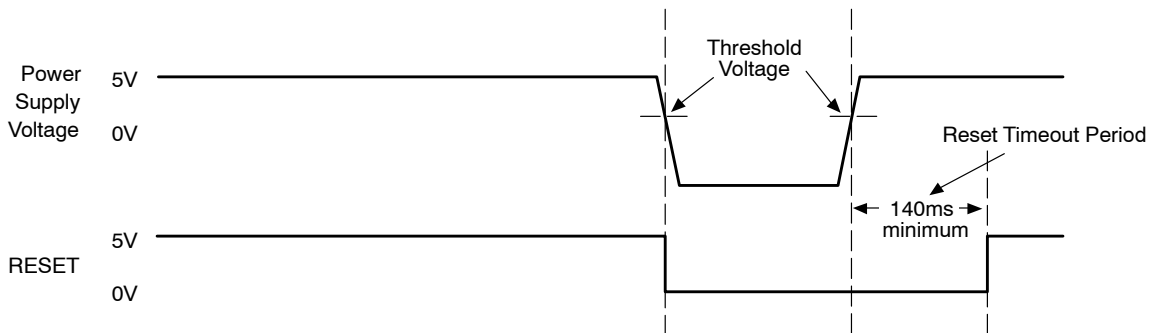
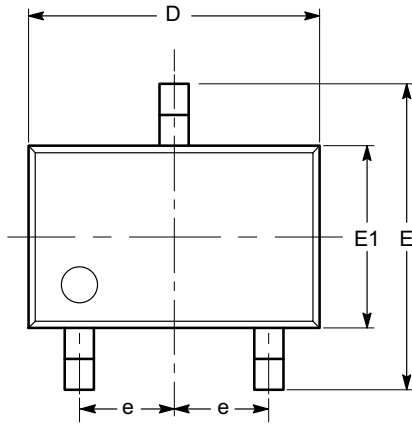

Figure 5. Reset Timing Diagram

CAT8801

PACKAGE DIMENSIONS

SC-70, 3 Lead, 1.25x2
 CASE 419AB-01
 ISSUE O



TOP VIEW

SYMBOL	MIN	NOM	MAX
A	0.80		1.10
A1	0.00		0.10
A2	0.80	0.90	1.00
b	0.15		0.30
c	0.08		0.22
D	1.80	2.00	2.20
E	1.80	2.10	2.40
E1	1.15	1.25	1.35
e	0.65 BSC		
L	0.26	0.36	0.46
L1	0.42 REF		
L2	0.15 BSC		
θ	0°		8°
θ_1	4°		10°

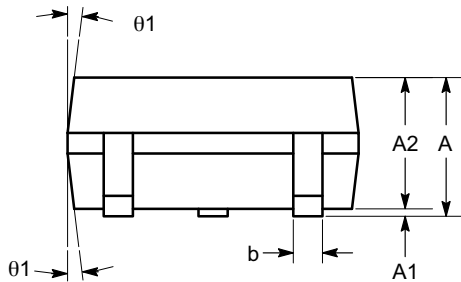

SIDE VIEW

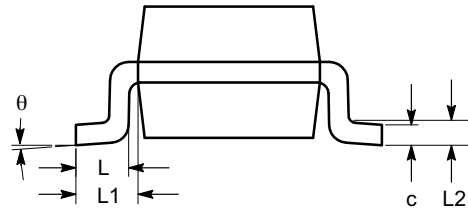

END VIEW

Notes:

- (1) All dimensions are in millimeters. Angles in degrees.
- (2) Complies with JEDEC MO-203.

CAT8801

PACKAGE DIMENSIONS

SOT-23, 3 Lead
CASE 527AG-01
ISSUE O

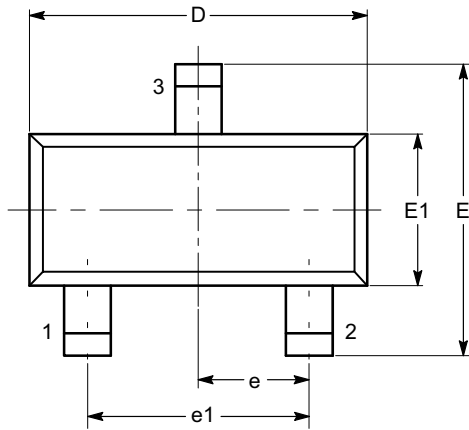

TOP VIEW

SYMBOL	MIN	NOM	MAX
A	0.89		1.12
A1	0.013		0.10
b	0.37		0.50
c	0.085		0.18
D	2.80		3.04
E	2.10		2.64
E1	1.20		1.40
e	0.95 BSC		
e1	1.90 BSC		
L	0.40 REF		
L1	0.54 REF		
θ	0°		8°

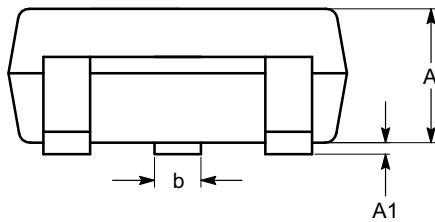

SIDE VIEW

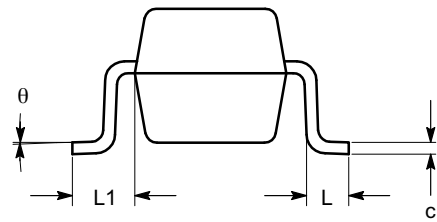

END VIEW

Notes:

- (1) All dimensions are in millimeters. Angles in degrees.
- (2) Complies with JEDEC TO-236.

CAT8801

Example of Ordering Information (Note 3)

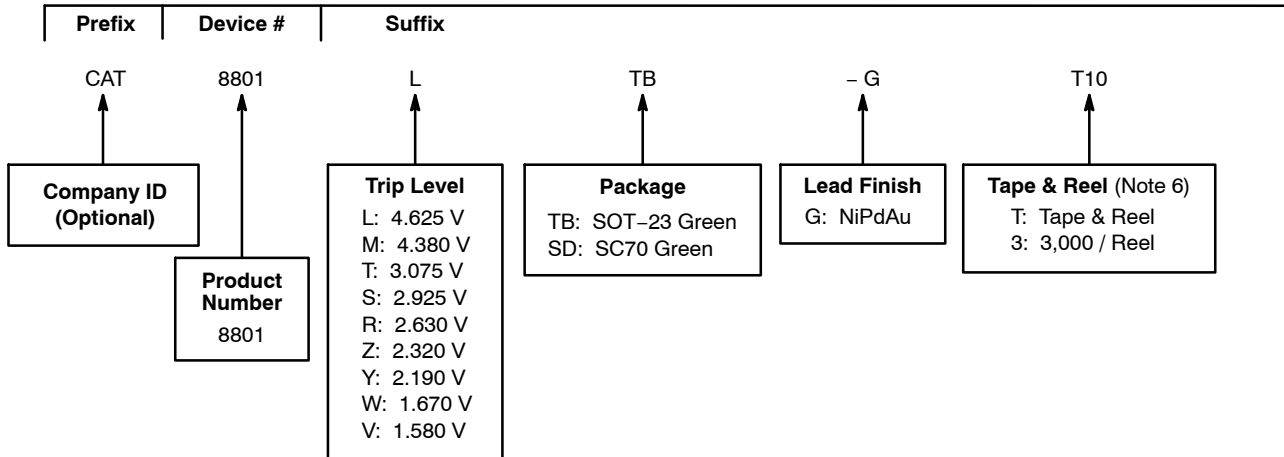

ORDERING INFORMATION

Parts and Threshold	Voltage	SOT-23 Green NiPdAu Lead Finish (Note 5)	SC-70 Green NiPdAu Lead Finish
CAT8801L	4.625	CAT8801LTB-GT3	CAT8801LSD-GT3
CAT8801M	4.380	CAT8801MTB-GT3	CAT8801MSD-GT3
CAT8801T	3.075	CAT8801TTB-GT3	CAT8801TSD-GT3
CAT8801S	2.925	CAT8801STB-GT3	CAT8801SSD-GT3
CAT8801R	2.630	CAT8801RTB-GT3	CAT8801RSD-GT3
CAT8801Z	2.320	CAT8801ZTB-GT3	CAT8801ZSD-GT3
CAT8801Y	2.190	CAT8801YTB-GT3	CAT8801YSD-GT3
CAT8801W	1.670	CAT8801WTB-GT3	CAT8801WSD-GT3
CAT8801V	1.580	CAT8801VTB-GT3	CAT8801VSD-GT3

- All packages are RoHS-compliant (Lead-free, Halogen-free).
- The device used in the above example is a CAT8801LTB-GT3 (4.625 V, SOT-23, NiPdAu, Tape & Reel, 3,000/Reel).
- For availability of the various voltage, package and temperature options, please contact your nearest ON Semiconductor sales office.
- For information on tape and reel specifications, including part orientation and tape sizes, please refer to our Tape and Reel Packaging Specifications Brochure, BRD8011/D.

ON Semiconductor and  are registered trademarks of Semiconductor Components Industries, LLC (SCILLC). SCILLC reserves the right to make changes without further notice to any products herein. SCILLC makes no warranty, representation or guarantee regarding the suitability of its products for any particular purpose, nor does SCILLC assume any liability arising out of the application or use of any product or circuit, and specifically disclaims any and all liability, including without limitation special, consequential or incidental damages. "Typical" parameters which may be provided in SCILLC data sheets and/or specifications can and do vary in different applications and actual performance may vary over time. All operating parameters, including "Typicals" must be validated for each customer application by customer's technical experts. SCILLC does not convey any license under its patent rights nor the rights of others. SCILLC products are not designed, intended, or authorized for use as components in systems intended for surgical implant into the body, or other applications intended to support or sustain life, or for any other application in which the failure of the SCILLC product could create a situation where personal injury or death may occur. Should Buyer purchase or use SCILLC products for any such unintended or unauthorized application, Buyer shall indemnify and hold SCILLC and its officers, employees, subsidiaries, affiliates, and distributors harmless against all claims, costs, damages, and expenses, and reasonable attorney fees arising out of, directly or indirectly, any claim of personal injury or death associated with such unintended or unauthorized use, even if such claim alleges that SCILLC was negligent regarding the design or manufacture of the part. SCILLC is an Equal Opportunity/Affirmative Action Employer. This literature is subject to all applicable copyright laws and is not for resale in any manner.

PUBLICATION ORDERING INFORMATION

LITERATURE FULFILLMENT:
 Literature Distribution Center for ON Semiconductor
 P.O. Box 5163, Denver, Colorado 80217 USA
Phone: 303-675-2175 or 800-344-3860 Toll Free USA/Canada
Fax: 303-675-2176 or 800-344-3867 Toll Free USA/Canada
Email: orderlit@onsemi.com

N. American Technical Support: 800-282-9855 Toll Free
 USA/Canada
Europe, Middle East and Africa Technical Support:
 Phone: 421 33 790 2910
Japan Customer Focus Center
 Phone: 81-3-5773-3850

ON Semiconductor Website: www.onsemi.com
Order Literature: <http://www.onsemi.com/orderlit>

For additional information, please contact your local Sales Representative

Looking for pricing, stock, or lifecycle information?

Click below to explore more details on WIN SOURCE:

 [View CAT8801MTB-GT3 on WIN SOURCE](#)

 [ON Semiconductor](#) Information

Optimize Your Supply Chain with WIN SOURCE Solutions

-  Global Sourcing Solution
-  Obsolete Management
-  Cost Control Management
-  Shortage Management
-  Alternative Solution
-  Excess Inventory Management