



# THE DATASHEET OF STL45P3LLH6



## P-channel -30 V, 11 mΩ typ., -45 A STripFET™ H6 Power MOSFET in a PowerFLAT™ 5x6 package

Datasheet - production data

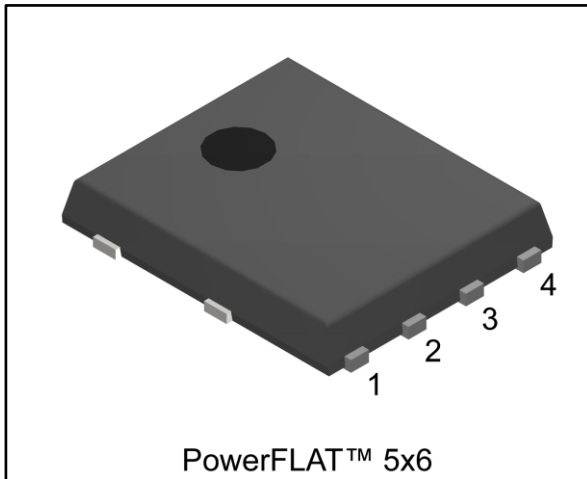
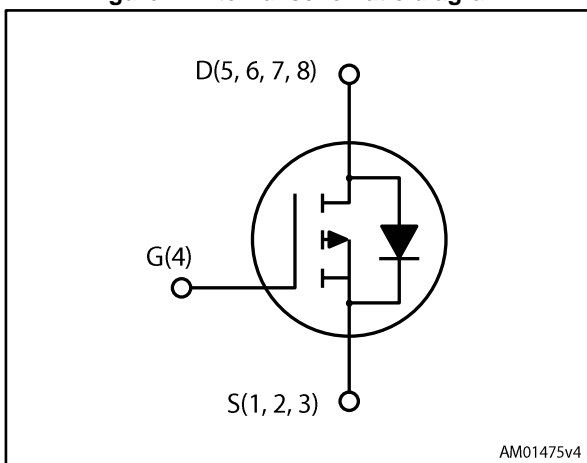

Figure 1: Internal schematic diagram



### Features

Order code	V <sub>DS</sub>	R <sub>DS(on)</sub> max	I <sub>D</sub>
STL45P3LLH6	-30 V	13 mΩ	-45 A

- Very low on-resistance
- Very low gate charge
- High avalanche ruggedness
- Low gate drive power loss

### Applications

- Switching applications

### Description

This device is a P-channel Power MOSFET developed using the STripFET™ H6 technology with a new trench gate structure. The resulting Power MOSFET exhibits very low R<sub>DS(on)</sub> in all packages.

Table 1: Device summary

Order code	Marking	Package	Packing
STL45P3LLH6	45P3LLH6	PowerFLAT™ 5x6	Tape and reel

---

**Contents**

<b>1</b>	<b>Electrical ratings .....</b>	<b>3</b>
<b>2</b>	<b>Electrical characteristics .....</b>	<b>4</b>
	2.1 Electrical characteristics (curves) .....	6
<b>3</b>	<b>Test circuits .....</b>	<b>8</b>
<b>4</b>	<b>Package information .....</b>	<b>9</b>
	4.1 PowerFLAT™ 5x6 package information.....	10
	4.2 PowerFLAT™ 5x6 packaging information.....	12
<b>5</b>	<b>Revision history .....</b>	<b>14</b>

# 1 Electrical ratings

Table 2: Absolute maximum ratings

Symbol	Parameter	Value	Unit
$V_{DS}$	Drain-source voltage	-30	V
$V_{GS}$	Gate-source voltage	$\pm 20$	V
$I_D^{(1)}$	Drain current (continuous) at $T_C = 25\text{ }^\circ\text{C}$	-45	A
$I_D^{(1)}$	Drain current (continuous) at $T_C = 100\text{ }^\circ\text{C}$	-34	A
$I_D^{(2)}$	Drain current (continuous) at $T_{pcb} = 25\text{ }^\circ\text{C}$	-12	A
$I_D^{(2)}$	Drain current (continuous) at $T_{pcb} = 100\text{ }^\circ\text{C}$	-8.7	A
$I_{DM}^{(1)(3)}$	Drain current (pulsed)	-180	A
$I_{DM}^{(2)(3)}$	Drain current (pulsed)	-48	A
$P_{TOT}^{(1)}$	Total dissipation at $T_C = 25\text{ }^\circ\text{C}$	75	W
$P_{TOT}^{(2)}$	Total dissipation at $T_{pcb} = 25\text{ }^\circ\text{C}$	4.8	W
$T_{stg}$	Storage temperature range	- 55 to 175	$^\circ\text{C}$
$T_j$	Operating junction temperature range		

**Notes:**

- (1) The value is rated according to  $R_{thj-c}$ .  
 (2) This value is rated according to  $R_{thj-pcb}$ .  
 (3) Pulse width is limited by safe operating area

Table 3: Thermal data

Symbol	Parameter	Value	Unit
$R_{thj-case}$	Thermal resistance junction-case	2.00	$^\circ\text{C/W}$
$R_{thj-pcb}^{(1)}$	Thermal resistance junction-pcb	31.3	$^\circ\text{C/W}$

**Notes:**

- (1) When mounted on FR-4 board of 1inch<sup>2</sup>, 2oz Cu,  $t < 10\text{ sec}$

## 2 Electrical characteristics

( $T_C = 25\text{ }^\circ\text{C}$  unless otherwise specified)

**Table 4: On /off states**

Symbol	Parameter	Test conditions	Min.	Typ.	Max.	Unit
$V_{(BR)DSS}$	Drain-source breakdown voltage	$V_{GS} = 0, I_D = -1\text{ mA}$	-30			V
$I_{DSS}$	Zero gate voltage drain current	$V_{GS} = 0, V_{DS} = -30\text{ V}$			-1	$\mu\text{A}$
		$V_{GS} = 0, V_{DS} = -30\text{ V}, T_C = 125\text{ }^\circ\text{C}$ <sup>(1)</sup>			-10	$\mu\text{A}$
$I_{GSS}$	Gate-body leakage current	$V_{DS} = 0, V_{GS} = \pm 20\text{ V}$			$\pm 100$	nA
$V_{GS(th)}$	Gate threshold voltage	$V_{DS} = V_{GS}, I_D = -250\text{ }\mu\text{A}$	-1			V
$R_{DS(on)}$	Static drain-source on- resistance	$V_{GS} = -10\text{ V}, I_D = -6\text{ A}$		11	13	$\text{m}\Omega$
		$V_{GS} = -4.5\text{ V}, I_D = -6\text{ A}$		16	19.5	$\text{m}\Omega$

**Notes:**

<sup>(1)</sup> Defined by design, not subject to production test.

**Table 5: Dynamic**

Symbol	Parameter	Test conditions	Min.	Typ.	Max.	Unit
$C_{iss}$	Input capacitance	$V_{DS} = -25\text{ V}, f = 1\text{ MHz}, V_{GS} = 0$	-	2615	-	pF
$C_{oss}$	Output capacitance		-	340	-	pF
$C_{rss}$	Reverse transfer capacitance		-	235	-	pF
$Q_g$	Total gate charge	$V_{DD} = -15\text{ V}, I_D = -12\text{ A}, V_{GS} = -4.5\text{ V}$	-	24	-	nC
$Q_{gs}$	Gate-source charge		-	9	-	nC
$Q_{gd}$	Gate-drain charge		-	8	-	nC

**Table 6: Switching times**

Symbol	Parameter	Test conditions	Min.	Typ.	Max.	Unit
$t_{d(on)}$	Turn-on delay time	$V_{DD} = -15\text{ V}, I_D = -6\text{ A}, R_G = 4.7\text{ }\Omega, V_{GS} = -10\text{ V}$	-	13.2	-	ns
$t_r$	Rise time		-	93	-	ns
$t_{d(off)}$	Turn-off delay time		-	50	-	ns
$t_f$	Fall time		-	18	-	ns

Table 7: Source drain diode

Symbol	Parameter	Test conditions	Min.	Typ.	Max.	Unit
$V_{SD}^{(1)}$	Forward on voltage	$I_{SD} = -6 \text{ A}$ , $V_{GS} = 0$	-		-1.1	V
$t_{rr}$	Reverse recovery time	$I_{SD} = -6 \text{ A}$ , $di/dt = 100 \text{ A}/\mu\text{s}$ $V_{DD} = -16 \text{ V}$ , $T_j = 150 \text{ }^\circ\text{C}$	-	20		ns
$Q_{rr}$	Reverse recovery charge		-	16		nC
$I_{RRM}$	Reverse recovery current		-	-1.6		A

**Notes:**

<sup>(1)</sup>Pulsed: pulse duration = 300  $\mu\text{s}$ , duty cycle 1.5%

## 2.2 Electrical characteristics (curves)



Note: For the P-channel Power MOSFET, current and voltage polarities are reversed.

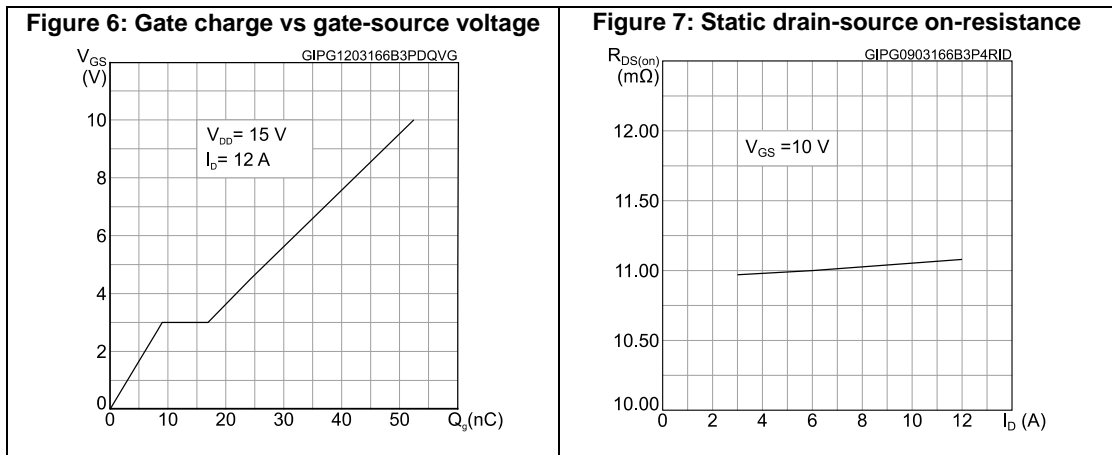
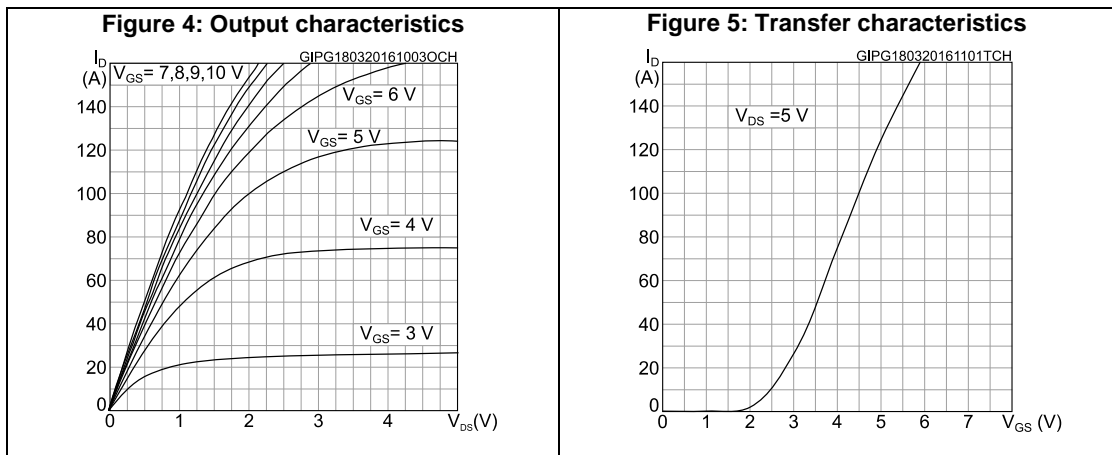
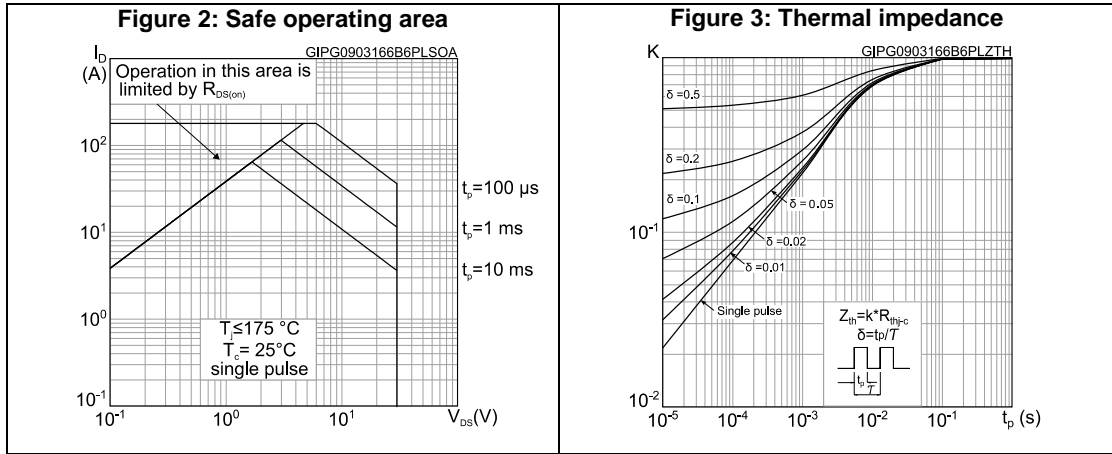

Figure 8: Capacitance variations

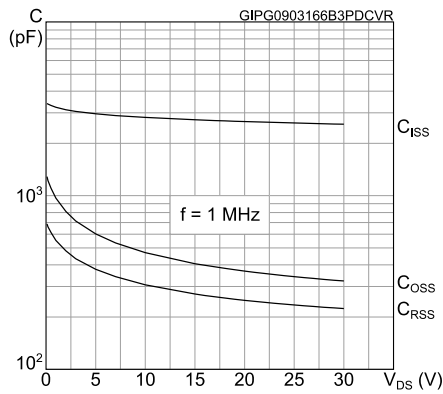

Figure 9: Normalized gate threshold voltage vs temperature

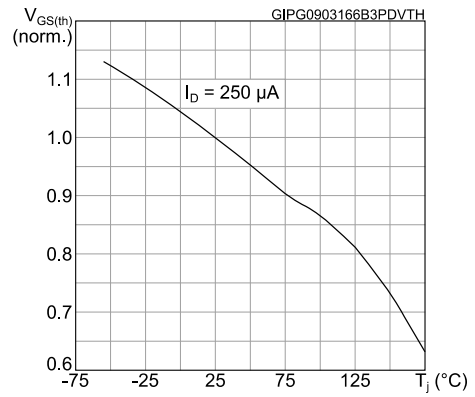

Figure 10: Normalized on-resistance vs temperature

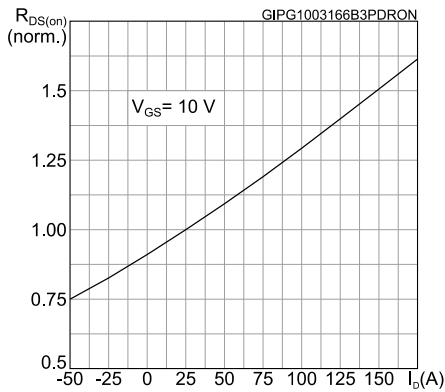

Figure 11: Normalized  $V_{(BR)DSS}$  vs temperature

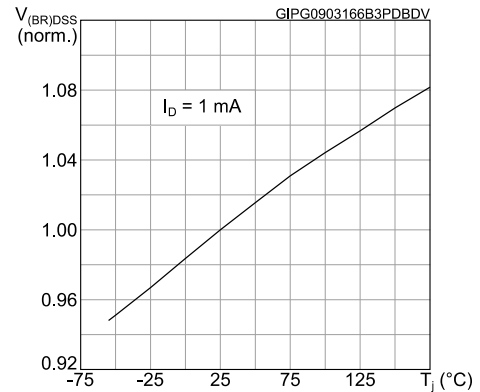
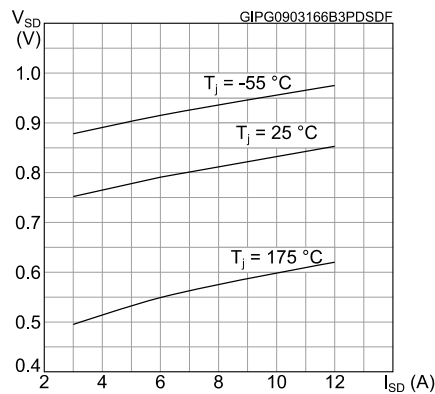

Figure 12: Source-drain diode forward characteristics



### 3 Test circuits

Figure 13: Switching times test circuit for resistive load

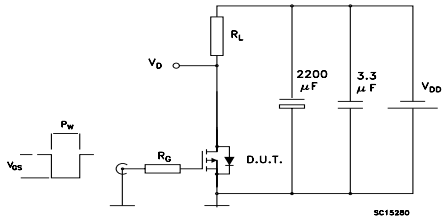

Figure 14: Gate charge test circuit

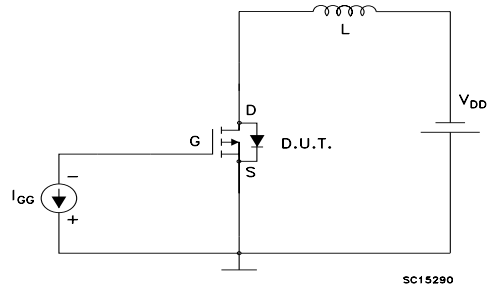
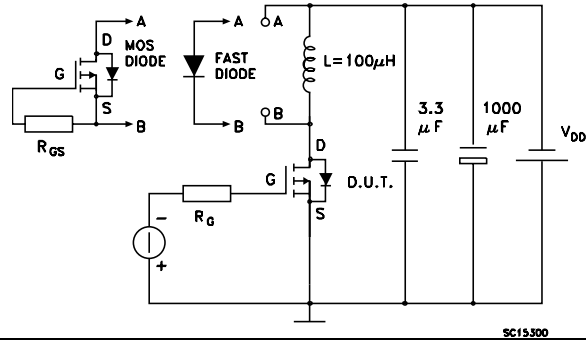

Figure 15: Test circuit for inductive load switching and diode recovery times



## 4 Package information

In order to meet environmental requirements, ST offers these devices in different grades of ECOPACK<sup>®</sup> packages, depending on their level of environmental compliance. ECOPACK<sup>®</sup> specifications, grade definitions and product status are available at: [www.st.com](http://www.st.com). ECOPACK<sup>®</sup> is an ST trademark.

### 4.1 PowerFLAT™ 5x6 package information

Figure 16: PowerFLAT™ 5x6 type R package outline

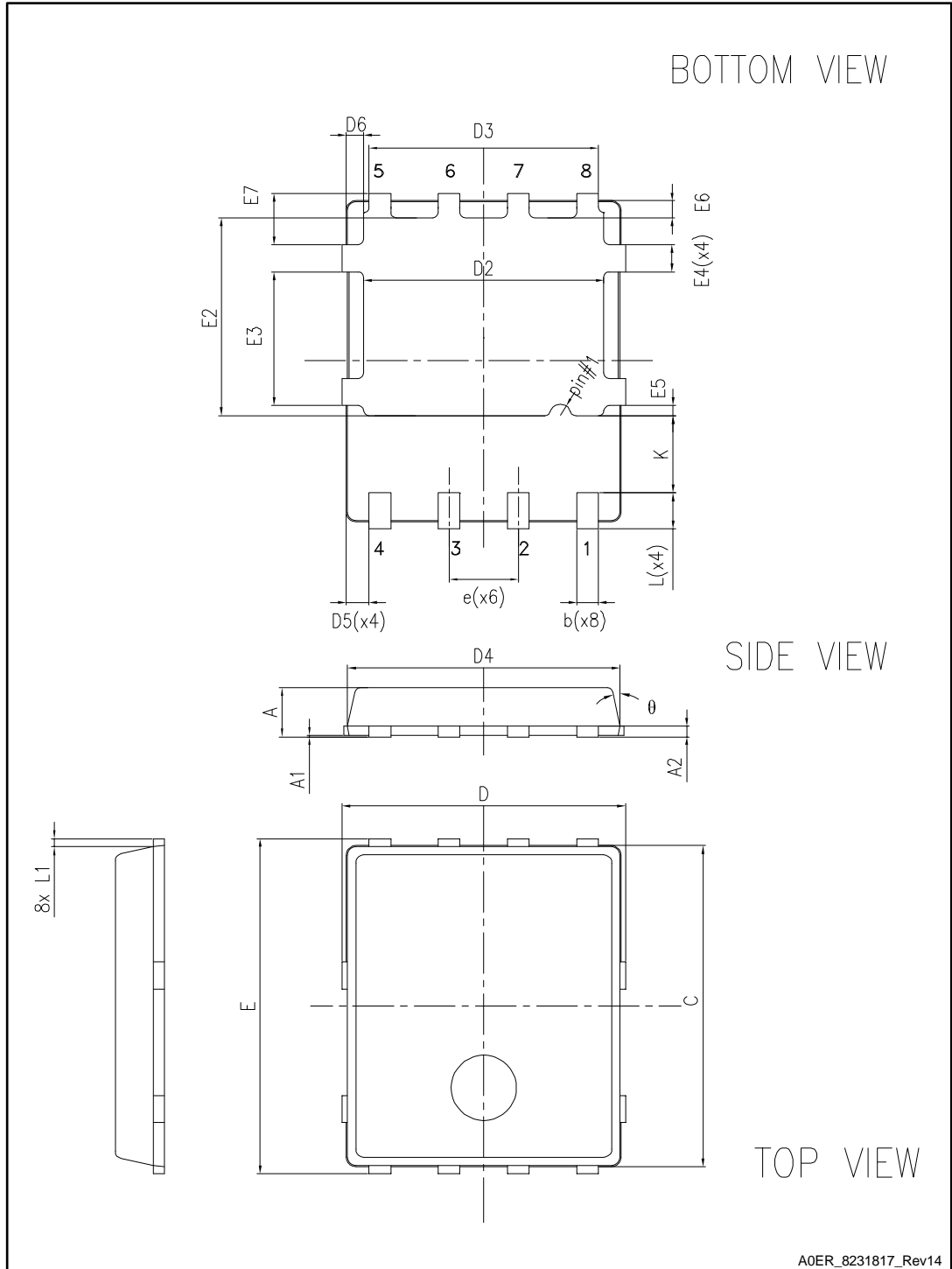
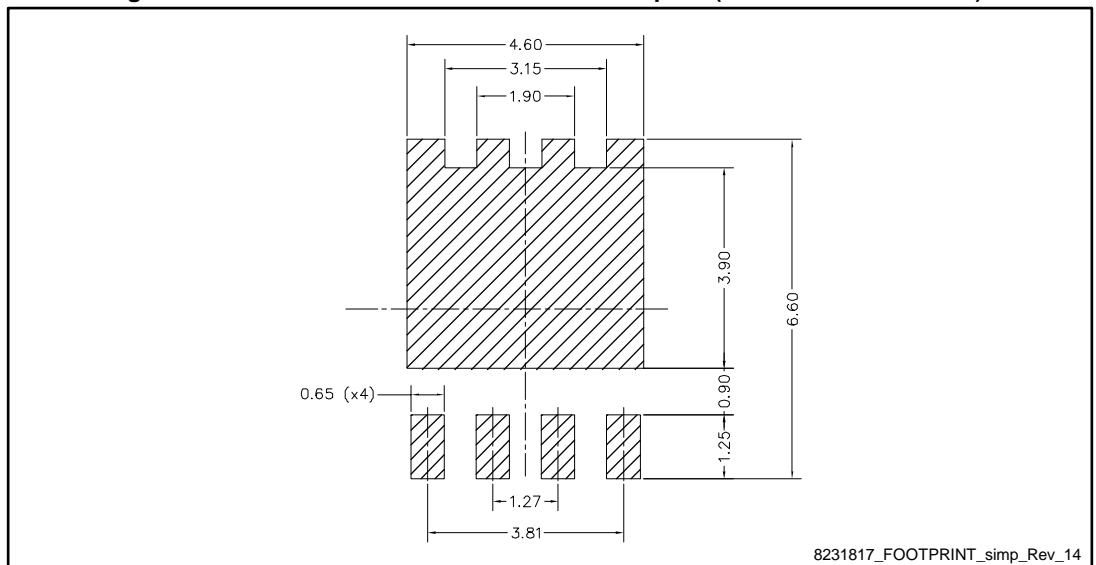

Table 8: PowerFLAT™ 5x6 type R mechanical data

Dim.	mm		
	Min.	Typ.	Max.
A	0.80		1.00
A1	0.02		0.05
A2		0.25	
b	0.30		0.50
C	5.80	6.00	6.20
D	5.00	5.20	5.40
D2	4.15		4.45
D3	4.05	4.20	4.35
D4	4.80	5.00	5.20
D5	0.25	0.40	0.55
D6	0.15	0.30	0.45
e		1.27	
E	5.95	6.15	6.35
E2	3.50		3.70
E3	2.35		2.55
E4	0.40		0.60
E5	0.08		0.28
E6	0.20	0.325	0.45
E7	0.75	0.90	1.05
K	1.275		1.575
L	0.60		0.80
L1	0.05	0.15	0.25
θ		0°	12°

Figure 17: PowerFLAT™ 5x6 recommended footprint (dimensions are in mm)



## 4.2 PowerFLAT™ 5x6 packaging information

Figure 18: PowerFLAT™ 5x6 tape (dimensions are in mm)

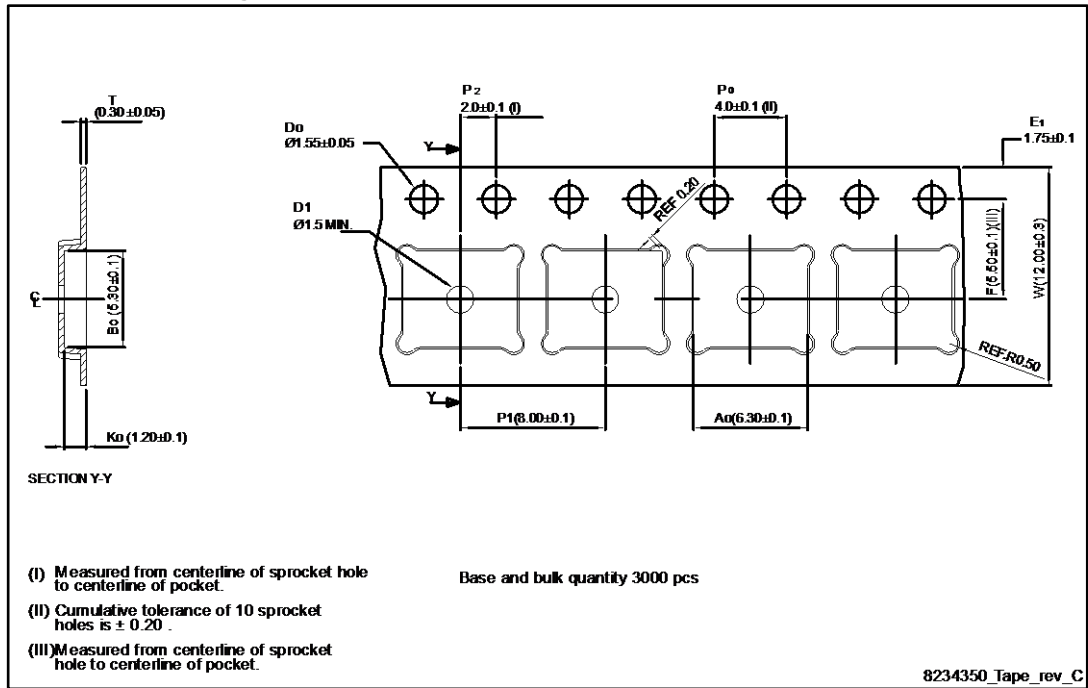

Figure 19: PowerFLAT™ 5x6 package orientation in carrier tape

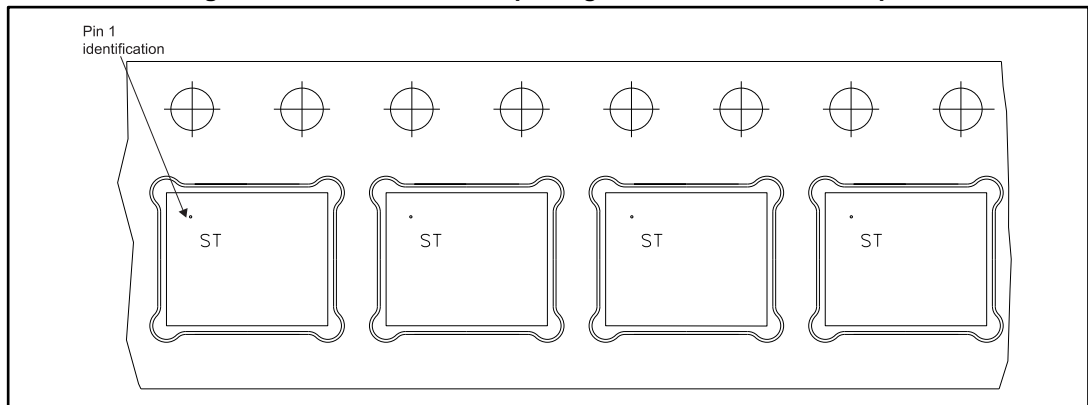
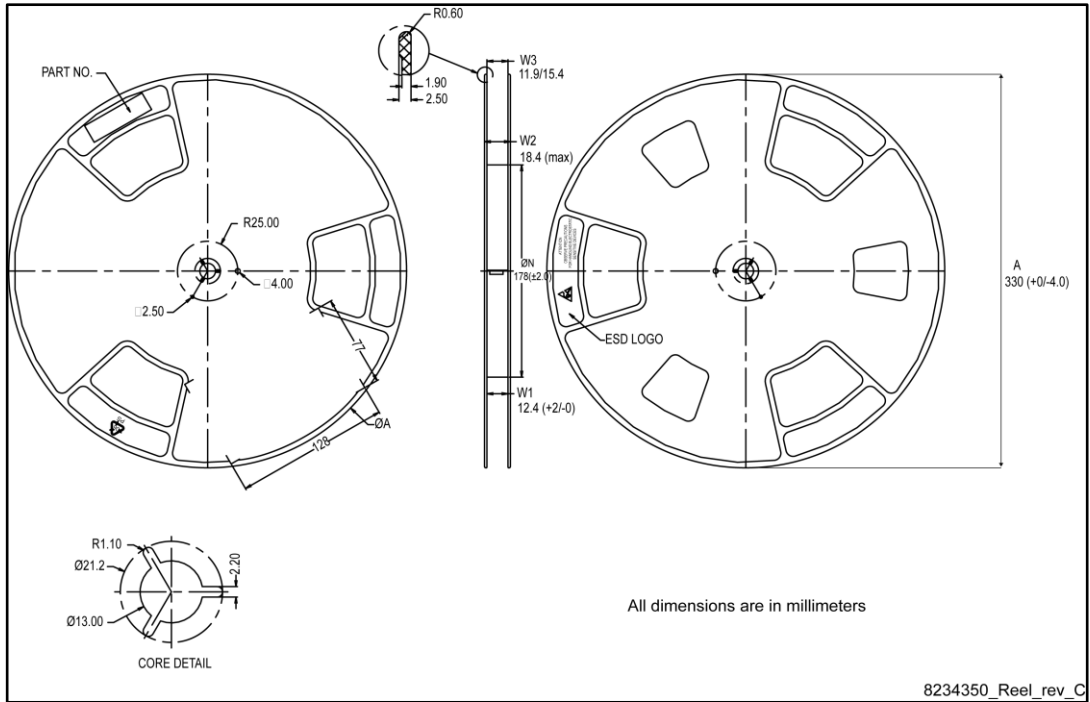

Figure 20: PowerFLAT™ 5x6 reel



## 5 Revision history

Table 9: Document revision history

Date	Revision	Changes
01-Apr-2016	1	First release.

**IMPORTANT NOTICE – PLEASE READ CAREFULLY**

STMicroelectronics NV and its subsidiaries ("ST") reserve the right to make changes, corrections, enhancements, modifications, and improvements to ST products and/or to this document at any time without notice. Purchasers should obtain the latest relevant information on ST products before placing orders. ST products are sold pursuant to ST's terms and conditions of sale in place at the time of order acknowledgement.

Purchasers are solely responsible for the choice, selection, and use of ST products and ST assumes no liability for application assistance or the design of Purchasers' products.

No license, express or implied, to any intellectual property right is granted by ST herein.

Resale of ST products with provisions different from the information set forth herein shall void any warranty granted by ST for such product.



ST and the ST logo are trademarks of ST. All other product or service names are the property of their respective owners.

Information in this document supersedes and replaces information previously supplied in any prior versions of this document.

© 2016 STMicroelectronics – All rights reserved

## Looking for pricing, stock, or lifecycle information?

Click below to explore more details on WIN SOURCE:

-  [View STL45P3LLH6 on WIN SOURCE](#)
-  [STMicroelectronics](#) Information

## Optimize Your Supply Chain with WIN SOURCE Solutions

-  Global Sourcing Solution
-  Obsolete Management
-  Cost Control Management
-  Shortage Management
-  Alternative Solution
-  Excess Inventory Management