



## 1:3 LVPECL CLOCK BUFFER WITH PROGRAMMABLE DIVIDER

### FEATURES

- Distributes One Differential Clock Input to Three LVPECL Differential Clock Outputs
- Programmable Output Divider for Two LVPECL Outputs
- Low-Output Skew 15 ps (Typical)
- $V_{CC}$  Range 3 V–3.6 V
- Signaling Rate Up to 800-MHz LVPECL
- Differential Input Stage for Wide Common-Mode Range
- Provides VBB Bias Voltage Output for Single-Ended Input Signals
- Receiver Input Threshold  $\pm 75$  mV
- 24-Terminal QFN Package (4 mm  $\times$  4 mm)
- Accepts Any Differential Signaling: LVDS, HSTL, CML, VML, SSTL-2, and Single-Ended: LVTTTL/LVCMOS

### SUPPORTS DEFENSE, AEROSPACE, AND MEDICAL APPLICATIONS

- Controlled Baseline
- One Assembly/Test Site
- One Fabrication Site
- Available in Military ( $-55^{\circ}\text{C}/125^{\circ}\text{C}$ ) Temperature Range<sup>(1)</sup>
- Extended Product Life Cycle
- Extended Product-Change Notification
- Product Traceability

(1) Additional temperature ranges available - contact factory

### DESCRIPTION/ORDERING INFORMATION

The CDCP1803 clock driver distributes one pair of differential clock inputs to three pairs of LVPECL differential clock outputs Y[2:0] and  $\bar{Y}$ [2:0] with minimum skew for clock distribution. The CDCP1803 is specifically designed for driving 50- $\Omega$  transmission lines.

The CDCP1803 has three control terminals, S0, S1, and S2, to select different output mode settings; see [Table 1](#) for details. The CDCP1803 is characterized for operation from  $-55^{\circ}\text{C}$  to  $125^{\circ}\text{C}$ . For use in single-ended driver applications, the CDCP1803 also provides a VBB output terminal that can be directly connected to the unused input as a common-mode voltage reference.

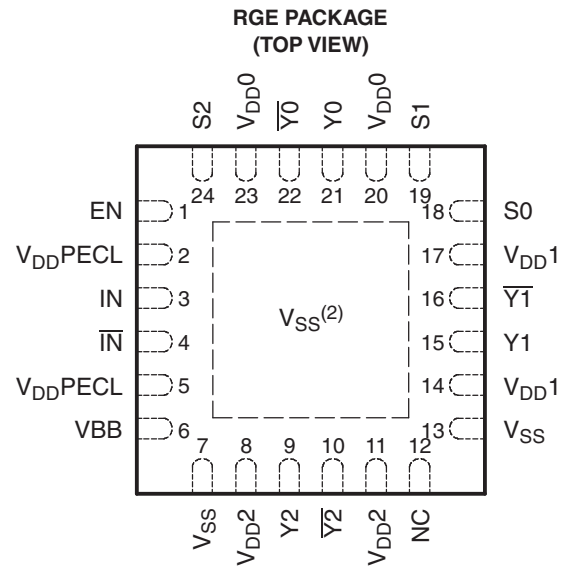

(2) Thermal pad must be connected to  $V_{SS}$ .

P0024-02



Please be aware that an important notice concerning availability, standard warranty, and use in critical applications of Texas Instruments semiconductor products and disclaimers thereto appears at the end of this data sheet.

**ORDERING INFORMATION<sup>(1)</sup>**

$T_A$	PACKAGE <sup>(2)</sup>		ORDERABLE PART NUMBER	TOP-SIDE MARKING
-55°C to 125°C	VQFN-RGE	Reel of 250	CDCP1803MRGETEP	CDCP1803EP

- (1) For the most current package and ordering information, see the Package Option Addendum at the end of this document, or see the TI Web site at [www.ti.com](http://www.ti.com).
- (2) Package drawings, standard packing quantities, thermal data, symbolization, and PCB design guidelines are available at [www.ti.com/sc/package](http://www.ti.com/sc/package).

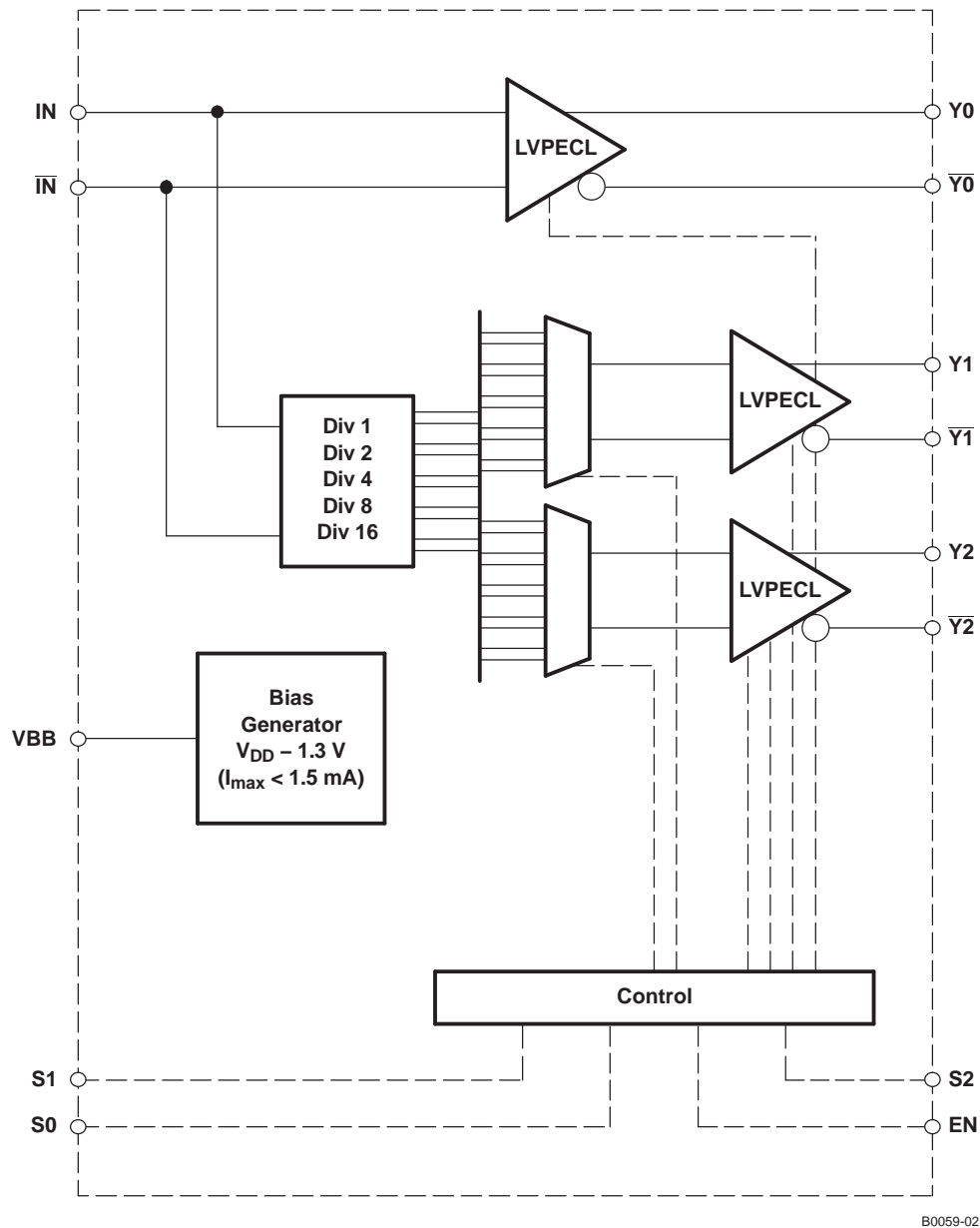
**FUNCTIONAL BLOCK DIAGRAM**

**TERMINAL FUNCTIONS**

TERMINAL		I/O	DESCRIPTION
NAME	NO.		
EN	1	I (with 60-k $\Omega$ pullup)	<p>ENABLE: Enables or disables all outputs simultaneously.</p> <p>EN = 1: outputs on according to S[2:0] settings            EN = 0: outputs Y[2:0] off (high impedance)            See <a href="#">Table 1</a> for details.</p>
IN, $\overline{\text{IN}}$	3, 4	I (differential)	<p>Differential input clock. Input stage is sensitive and has a wide common-mode range. Therefore, almost any type of differential signal can drive this input (LVPECL, LVDS, CML, HSTL). Because the input is high-impedance, it is recommended to terminate the PCB transmission line before the input (e.g., with 100 <math>\Omega</math> across input). Input can also be driven by a single-ended signal if the complementary input is tied to VBB. A more-advanced scheme for single-ended signals is given in the <i>Application Information</i> section near the end of this document.</p> <p>The inputs employ an ESD structure protecting the inputs in case of an input voltage exceeding the rails by more than ~0.7 V. Reverse biasing of the IC through these inputs is possible and must be prevented by limiting the input voltage &lt; <math>V_{DD}</math>.</p>
NC	12		No connect. Leave this terminal open or tie to ground.
S[2:0]	24, 19, 18	I (with 60-k $\Omega$ pullup)	Select mode of operation. Defines the output configuration of Y[2:0], see <a href="#">Table 1</a> for configuration.
VBB	6	O	<p>Bias voltage output can be used to bias unused complementary input <math>\overline{\text{IN}}</math> for single-ended input signals.</p> <p>The output voltage of VBB is <math>V_{DD} - 1.3</math> V. When driving a load, the output current drive is limited to about 1.5 mA.</p>
$V_{DD}$ PECL	2, 5	Supply	Supply voltage PECL input + internal logic
$V_{DD}$ [2:0]	8, 11, 14, 17, 20, 23	Supply	<p>PECL output supply voltage for output Y[2:0]. Each output can be disabled by pulling the corresponding <math>V_{DDx}</math> to GND.</p> <p><b>CAUTION:</b> In this mode, no voltage from outside may be forced, because internal diodes could be forced in forward direction. Thus, it is recommended to disconnect the output if it is not being used.</p>
$V_{SS}$	7, 13	Supply	Device ground
$\overline{\text{Y}}[2:0]$ Y[2:0]	9, 15, 21 10, 16, 22	O (LVPECL)	LVPECL clock outputs. These outputs provide low-skew copies of IN or down-divided copies of clock IN based on selected mode of operation S[2:0]. If an output is unused, the output can simply be left open to save power and minimize noise impact to the remaining outputs.

## CONTROL TERMINAL SETTINGS

The CDCP1803 has three control terminals (S0, S1, and S2) and an enable terminal (EN) to select different output mode settings.

Setting for Mode 20:

EN = 1

S2 = 1

S1 = 0

S0 = 1

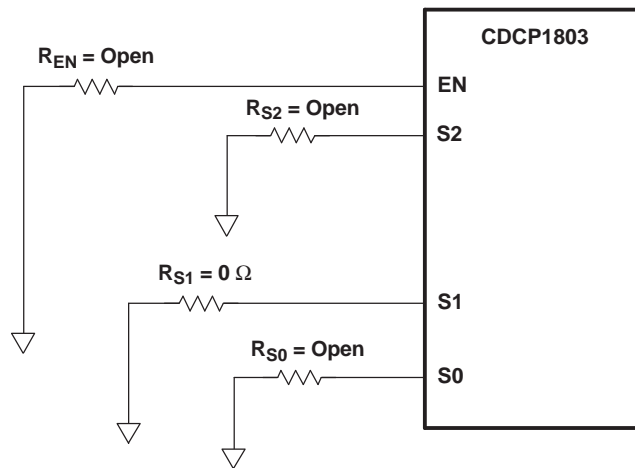

S0084-02

**Figure 1. Control Terminal Setting for Example**

**Table 1. Selection Mode Table**

MODE	EN	S2	S1	S0	LVPECL <sup>(1)</sup>		
					Y0	Y1	Y2
0	0	x	x	x	Off (high-z)		
1	1	0	0	0	÷ 1	÷ 1	÷ 1
2	1	0	0	V <sub>DD</sub> /2	÷ 1	Off (high-z)	Off (high-z)
3	1	0	0	1	÷ 1	÷ 1	Off (high-z)
4	1	0	V <sub>DD</sub> /2	0	÷ 1	÷ 2	Off (high-z)
5	1	0	V <sub>DD</sub> /2	V <sub>DD</sub> /2	÷ 1	÷ 4	Off (high-z)
6	1	0	V <sub>DD</sub> /2	1	÷ 1	÷ 8	Off (high-z)
7	1	0	1	0	÷ 1	Off (high-z)	÷ 1
8	1	0	1	1	÷ 1	÷ 2	÷ 1
9	1	V <sub>DD</sub> /2	0	0	÷ 1	÷ 4	÷ 1
10	1	V <sub>DD</sub> /2	0	V <sub>DD</sub> /2	÷ 1	÷ 8	÷ 1
11	1	V <sub>DD</sub> /2	0	1	÷ 1	Off (high-z)	÷ 2
12	1	V <sub>DD</sub> /2	V <sub>DD</sub> /2	0	÷ 1	÷ 1	÷ 2
13	1	V <sub>DD</sub> /2	V <sub>DD</sub> /2	V <sub>DD</sub> /2	÷ 1	÷ 2	÷ 2
14	1	V <sub>DD</sub> /2	V <sub>DD</sub> /2	1	÷ 1	÷ 4	÷ 2
15	1	V <sub>DD</sub> /2	1	0	÷ 1	÷ 8	÷ 2
16	1	V <sub>DD</sub> /2	1	V <sub>DD</sub> /2	÷ 1	Off (high-z)	÷ 4
17	1	V <sub>DD</sub> /2	1	1	÷ 1	÷ 1	÷ 4
18	1	1	0	0	÷ 1	÷ 2	÷ 4
19	1	1	0	V <sub>DD</sub> /2	÷ 1	÷ 4	÷ 4
20	1	1	0	1	÷ 1	÷ 8	÷ 4
21	1	1	V <sub>DD</sub> /2	0	÷ 1	Off (high-z)	÷ 8
22	1	1	V <sub>DD</sub> /2	V <sub>DD</sub> /2	÷ 1	÷ 1	÷ 8
23	1	1	V <sub>DD</sub> /2	1	÷ 1	÷ 2	÷ 8
24	1	1	1	0	÷ 1	÷ 4	÷ 8
25	1	1	1	V <sub>DD</sub> /2	÷ 1	÷ 8	÷ 8
26	1	1	1	1	÷ 1	Off (high-z)	÷ 16
27	V <sub>DD</sub> /2	0	0	0	÷ 1	÷ 1	÷ 16
28	V <sub>DD</sub> /2	0	0	V <sub>DD</sub> /2	÷ 1	÷ 2	÷ 16
29	V <sub>DD</sub> /2	0	0	1	÷ 1	÷ 4	÷ 16
30	V <sub>DD</sub> /2	0	V <sub>DD</sub> /2	0	÷ 1	÷ 8	÷ 16
Rsv	V <sub>DD</sub> /2	1	V <sub>DD</sub> /2	1	Reserved	Reserved	Reserved
Rsv	V <sub>DD</sub> /2	1	1	0	N/A	Low	Low

- (1) The LVPECL outputs are open-emitter stages. Thus, if the unused LVPECL outputs Y0, Y1, or Y2 are left unconnected, then the current consumption is minimized and noise impact to remaining outputs is neglectable. Also, each output can be individually disabled by connecting the corresponding V<sub>DD</sub> input to GND.

## ABSOLUTE MAXIMUM RATINGS

 over operating free-air temperature (unless otherwise noted)<sup>(1)</sup>

V <sub>DD</sub>	Supply voltage	–0.3 V to 3.8 V
V <sub>I</sub>	Input voltage	–0.2 V to (V <sub>DD</sub> + 0.2 V)
V <sub>O</sub>	Output voltage	–0.2 V to (V <sub>DD</sub> + 0.2 V)
	Differential short-circuit current, Y <sub>n</sub> , $\overline{Y}_n$ , I <sub>OSD</sub>	Continuous
	Electrostatic discharge (HBM 1.5 kΩ, 100 pF), ESD	>2000 V
	Moisture level 24-terminal QFN package (solder reflow temperature of 235°C) MSL	2
T <sub>stg</sub>	Storage temperature	–65°C to 150°C
T <sub>J</sub>	Maximum junction temperature	150°C

(1) Stresses beyond those listed under *absolute maximum ratings* may cause permanent damage to the device. These are stress ratings only, and functional operation of the device at these or any other conditions beyond those indicated under *recommended operating conditions* is not implied. Exposure to absolute-maximum-rated conditions for extended periods may affect device reliability.

## RECOMMENDED OPERATING CONDITIONS

		MIN	TYP	MAX	UNIT
V <sub>DD</sub>	Supply voltage	3	3.3	3.6	V
T <sub>A</sub>	Operating free-air temperature	–55		125	°C

## ELECTRICAL CHARACTERISTICS

over operating free-air temperature range (unless otherwise noted)

### LVPECL INPUT IN, $\overline{IN}$

PARAMETER		TEST CONDITIONS	MIN	TYP	MAX	UNIT
f <sub>clk</sub>	Input frequency		0		800	MHz
V <sub>CM</sub>	High-level input common mode		1	V <sub>DD</sub> – 0.3		V
V <sub>IN</sub>	Input voltage swing between IN and $\overline{IN}$ <sup>(1)</sup>		500		1300	mV
	Input voltage swing between IN and $\overline{IN}$ <sup>(2)</sup>		125		1300	
I <sub>IN</sub>	Input current	V <sub>I</sub> = V <sub>DD</sub> or 0 V			±10	μA
R <sub>IN</sub>	Input impedance		300			kΩ
C <sub>I</sub>	Input capacitance at IN, $\overline{IN}$			1		pF

- (1) Is required to maintain ac specifications  
 (2) Is required to maintain device functionality

**ELECTRICAL CHARACTERISTICS (continued)**

over operating free-air temperature range (unless otherwise noted)

**LVPECL OUTPUT DRIVER Y[2:0],  $\overline{Y[2:0]}$** 

PARAMETER		TEST CONDITIONS	MIN	TYP	MAX	UNIT
$f_{clk}$	Output frequency, see <a href="#">Figure 3</a> .		0		800	MHz
$V_{OH}$	High-level output voltage	Termination with 50 $\Omega$ to $V_{DD} - 2$ V	$V_{DD} - 1.18$		$V_{DD} - 0.81$	V
$V_{OL}$	Low-level output voltage	Termination with 50 $\Omega$ to $V_{DD} - 2$ V	$V_{DD} - 1.98$		$V_{DD} - 1.55$	V
$V_O$	Output voltage swing between Y and $\overline{Y}$ , see <a href="#">Figure 3</a> .	Termination with 50 $\Omega$ to $V_{DD} - 2$ V	500			mV
$I_{OZL}$	Output 3-state current	$V_{DD} = 3.6$ V, $V_O = 0$ V			5	$\mu$ A
$I_{OZH}$		$V_{DD} = 3.6$ V, $V_O = V_{DD} - 0.8$ V			10	
$t_r/t_f$	Rise and fall times	20% to 80% of $V_{OUTPP}$ , see <a href="#">Figure 8</a> .	170		400	ps
$t_{skpecl(o)}$	Output skew between any LVPECL output Y[2:0] and $\overline{Y[2:0]}$	See Note A in <a href="#">Figure 7</a> .		15	70	ps
$t_{Duty}$	Output duty-cycle distortion <sup>(1)</sup>	Crossing point-to-crossing point distortion	-50		50	ps
$t_{sk(pp)}$	Part-to-part skew	Any Y, see Note B in <a href="#">Figure 7</a> .		50		ps
$C_O$	Output capacitance	$V_O = V_{DD}$ or GND		1		pF
LOAD	Expected output load			50		$\Omega$

 (1) For an 800-MHz signal, the 50-ps error would result in a duty cycle distortion of  $\pm 4\%$  when driven by an ideal clock input signal.

**LVPECL INPUT-TO-LVPECL OUTPUT PARAMETERS**

PARAMETER		TEST CONDITIONS	MIN	TYP	MAX	UNIT
$t_{pd(lh)}$	Propagation delay, rising edge	VOX to VOX	320		600	ps
$t_{pd(hl)}$	Propagation delay, falling edge	VOX to VOX	320		600	ps
$t_{sk(p)}$	LVPECL pulse skew	VOX to VOX, see Note C in <a href="#">Figure 7</a> .			100	ps

**JITTER CHARACTERISTICS**

PARAMETER		TEST CONDITIONS	MIN	TYP	MAX	UNIT
<b>JITTER CHARACTERISTICS</b>						
$t_{jitterLVPECL}$	Additive phase jitter from input to LVPECL output Y[2:0], see <a href="#">Figure 2</a> .	12 kHz to 20 MHz, $f_{out} = 250$ MHz to 800 MHz, divide-by-1 mode		0.15		ps rms
		50 kHz to 40 MHz, $f_{out} = 250$ MHz to 800 MHz, divide-by-1 mode		0.25		

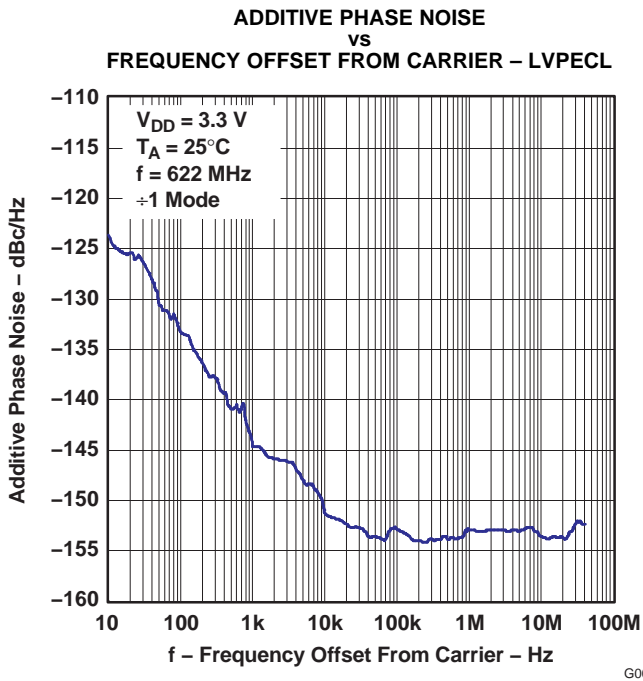

Figure 2.

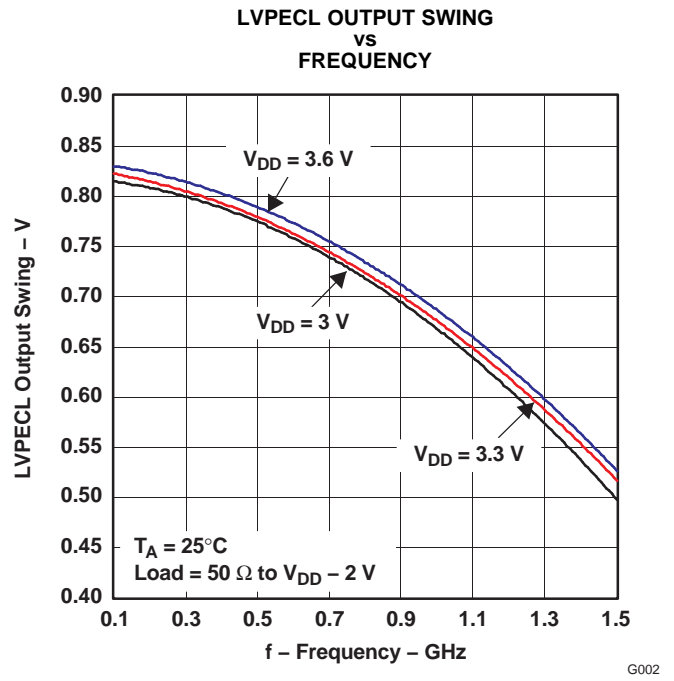
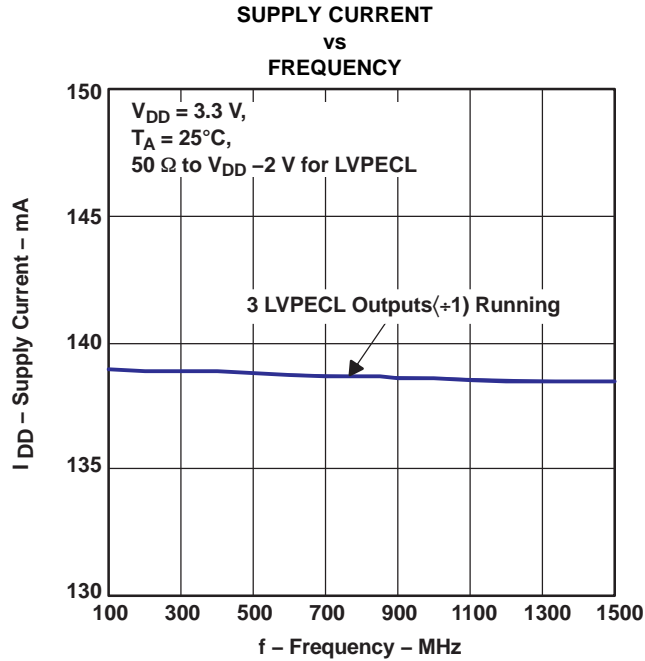

Figure 3.

### SUPPLY CURRENT ELECTRICAL CHARACTERISTICS

over recommended operating free-air temperature range (unless otherwise noted)

PARAMETER		TEST CONDITIONS		MIN	TYP	MAX	UNIT
I <sub>DD</sub>	Supply current	Full load	All outputs enabled and terminated with 50 Ω to V <sub>DD</sub> - 2 V on LVPECL outputs, f = 800 MHz for LVPECL outputs, V <sub>DD</sub> = 3.3 V		140		mA
		No load	Outputs enabled, no output load, f = 800 MHz for LVPECL outputs, V <sub>DD</sub> = 3.6 V			90	
	Supply current saving per LVPECL output stage disabled, no load	f = 800 MHz for LVPECL output, V <sub>DD</sub> = 3.3 V			10		
I <sub>DDZ</sub>	Supply current, 3-state		All outputs in high-impedance state by control logic, f = 0 Hz, V <sub>DD</sub> = 3.6 V			0.5	mA



**PACKAGE THERMAL RESISTANCE**

PARAMETER	TEST CONDITIONS	MIN	TYP	MAX	UNIT
R <sub>θJA-1</sub> QFN-24 package thermal resistance <sup>(1)</sup>	4-layer JEDEC test board (JESD51-7), airflow = 0 ft/min		106.6		°C/W
R <sub>θJA-2</sub> QFN-24 package thermal resistance with thermal vias in PCB <sup>(1)</sup>	4-layer JEDEC test board (JESD51-7) with four thermal vias of 22-mil diameter each, airflow = 0 ft/min		55.4		°C/W

(1) It is recommended to provide four thermal vias to connect the thermal pad of the package effectively with the PCB and ensure a good heat sink.

**Example:**

**Calculation of the junction-lead temperature with a 4-layer JEDEC test board using four thermal vias:**

$T_{\text{Chassis}} = 125^{\circ}\text{C}$  (temperature of the chassis)

$P_{\text{effective}} = I_{\text{max}} \times V_{\text{max}} = 90 \text{ mA} \times 3.6 \text{ V} = 324 \text{ mW}$  (max power consumption inside the package)

$\theta T_{\text{Junction}} = \theta_{\text{JA-2}} \times P_{\text{effective}} = 55.45^{\circ}\text{C/W} \times 324 \text{ mW} = 17.97^{\circ}\text{C}$

$T_{\text{Junction}} = \theta T_{\text{Junction}} + T_{\text{Chassis}} = 17.97^{\circ}\text{C} + 125^{\circ}\text{C} = 143^{\circ}\text{C}$  (see [Figure 5](#) for expected life with continuous 125°C operation)

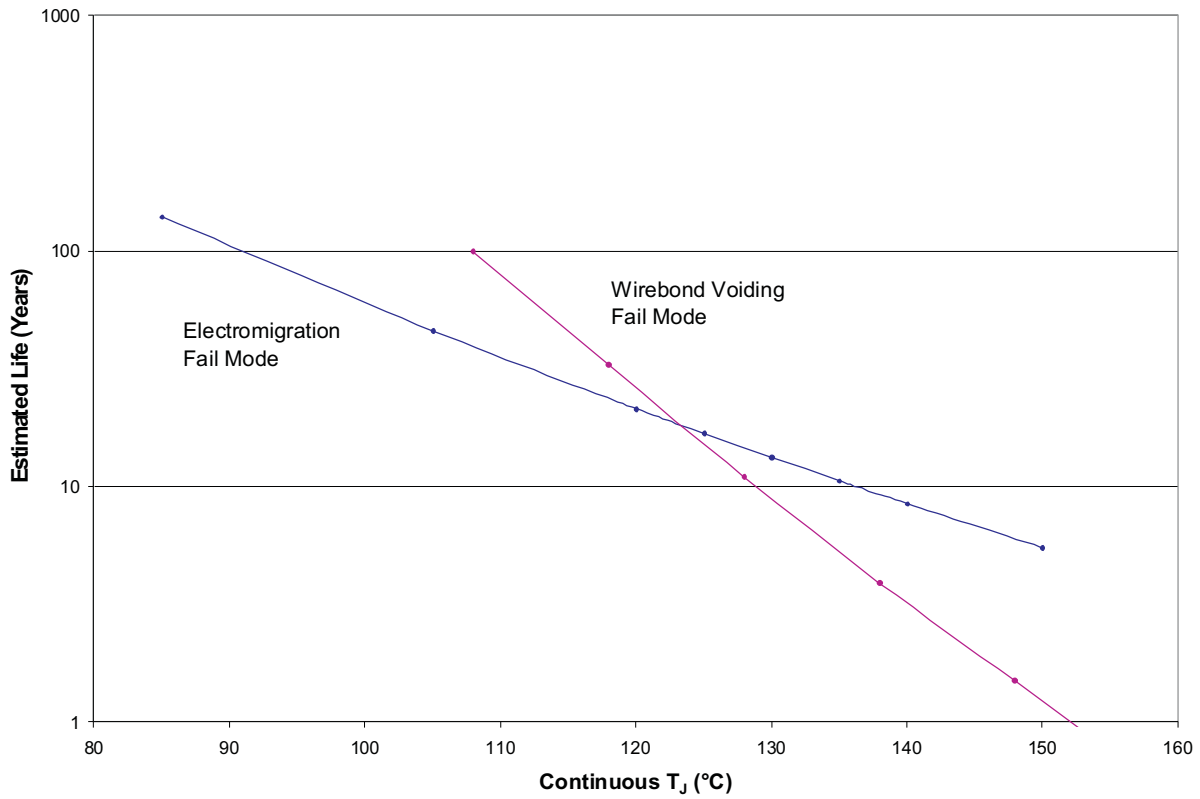

- (1) See data sheet for absolute maximum and minimum recommended operating conditions.
- (2) Silicon operating life design goal is 10 years at 105°C junction temperature (does not include package interconnect life).

**Figure 5. Operating Life Derating Chart**

### CONTROL INPUT CHARACTERISTICS

over recommended operating free-air temperature range

PARAMETER		TEST CONDITIONS	MIN	TYP	MAX	UNIT
$t_{su}$	Setup time, S0, S1, S2, and EN terminals before clock IN		25			ns
$t_h$	Hold time, S0, S1, S2, and EN terminals after clock IN		0			ns
$t_{(disable)}$	Time between latching the EN low transition and when all outputs are disabled (how much time is required until the outputs turn off)			10		ns
$t_{(enable)}$	Time between latching the EN low-to-high transition and when outputs are enabled based on control settings (how much time passes before the outputs carry valid signals)			1		$\mu s$
Rpullup	Internal pullup resistor on S[2:0] and EN input			60		k $\Omega$
$V_{IH(H)}$	Three-level input high, S0, S1, S2, and EN terminals <sup>(1)</sup>		0.9 $V_{DD}$			V
$V_{IL(L)}$	Three-level low, S0, S1, S2, and EN terminals				0.1 $V_{DD}$	V
$I_{IH}$	Input current, S0, S1, S2, and EN terminals	$V_I = V_{DD}$			-5	$\mu A$
$I_{IL}$		$V_I = GND$	38		85	$\mu A$

(1) Leaving this terminal floating automatically pulls the logic level high to  $V_{DD}$  through an internal pullup resistor of 60 k $\Omega$ .

### BIAS VOLTAGE $V_{BB}$

over operating free-air temperature range

PARAMETER	TEST CONDITIONS	MIN	TYP	MAX	UNIT
$V_{BB}$	Output reference voltage	$V_{DD} - 1.4$		$V_{DD} - 1.1$	V

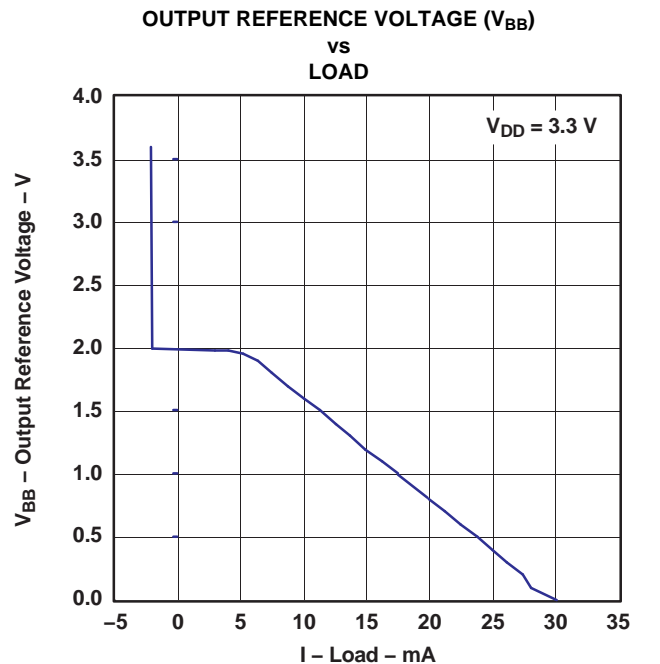
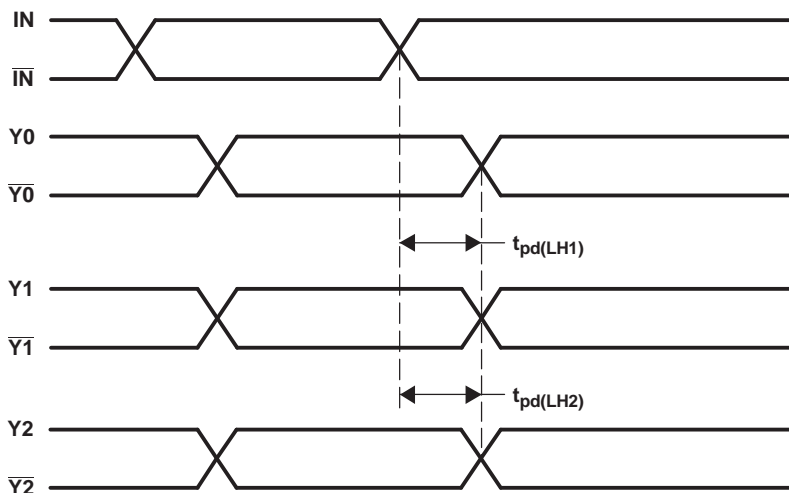

Figure 6.

G004

PARAMETER MEASUREMENT INFORMATION



- NOTES: A. Output skew,  $t_{sk(o)}$ , is calculated as the greater of:
- The difference between the fastest and the slowest  $t_{pd(LH)n}$  ( $n = 0 \dots 2$ )
  - The difference between the fastest and the slowest  $t_{pd(HL)n}$  ( $n = 0 \dots 2$ )
- B. Part-to-part skew,  $t_{sk(pp)}$ , is calculated as the greater of:
- The difference between the fastest and the slowest  $t_{pd(LH)n}$  ( $n = 0 \dots 2$  for LVPECL,  $n = 3$  for LVCMOS) across multiple devices
  - The difference between the fastest and the slowest  $t_{pd(HL)n}$  ( $n = 0 \dots 2$  for LVPECL,  $n = 3$  for LVCMOS) across multiple devices
- C. Pulse skew,  $t_{sk(p)}$ , is calculated as the magnitude of the absolute time difference between the high-to-low ( $t_{pd(HL)}$ ) and the low-to-high ( $t_{pd(LH)}$ ) propagation delays when a single switching input causes one or more outputs to switch,  $t_{sk(p)} = |t_{pd(HL)} - t_{pd(LH)}|$ . Pulse skew is sometimes referred to as *pulse width distortion* or *duty cycle skew*.

T0067-02

Figure 7. Waveforms for Calculation of  $t_{sk(o)}$  and  $t_{sk(pp)}$

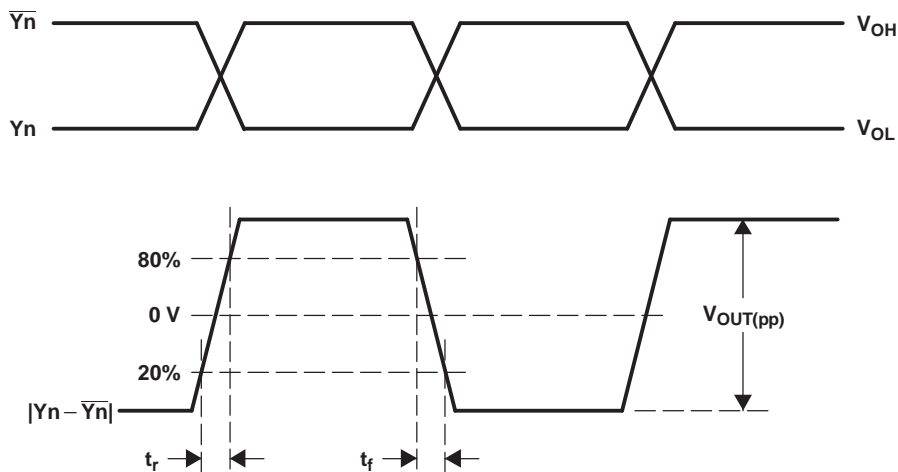

T0058-02

Figure 8. LVPECL Differential Output Voltage and Rise/Fall Time

PCB DESIGN FOR THERMAL FUNCTIONALITY

It is recommended to take special care of the PCB design for good thermal flow from the QFN 24-terminal package to the PCB.

Due to the three LVPECL outputs, the current consumption of the CDCP1803 is fixed.

JEDEC JESD51-7 specifies thermal conductivity for standard PCB boards.

**PARAMETER MEASUREMENT INFORMATION (continued)**

Modeling the CDCP1803 with a standard 4-layer JEDEC board results in a 59.5°C maximum temperature with  $R_{\theta JA}$  of 106.62°C/W for 25°C ambient temperature.

When deploying four thermal vias (one per quadrant), the thermal flow improves significantly, yielding 42.9°C maximum temperature with  $R_{\theta JA}$  of 55.4°C/W for 25°C ambient temperature.

To ensure sufficient thermal flow, it is recommended to design with four thermal vias in applications enabling all four outputs at once.

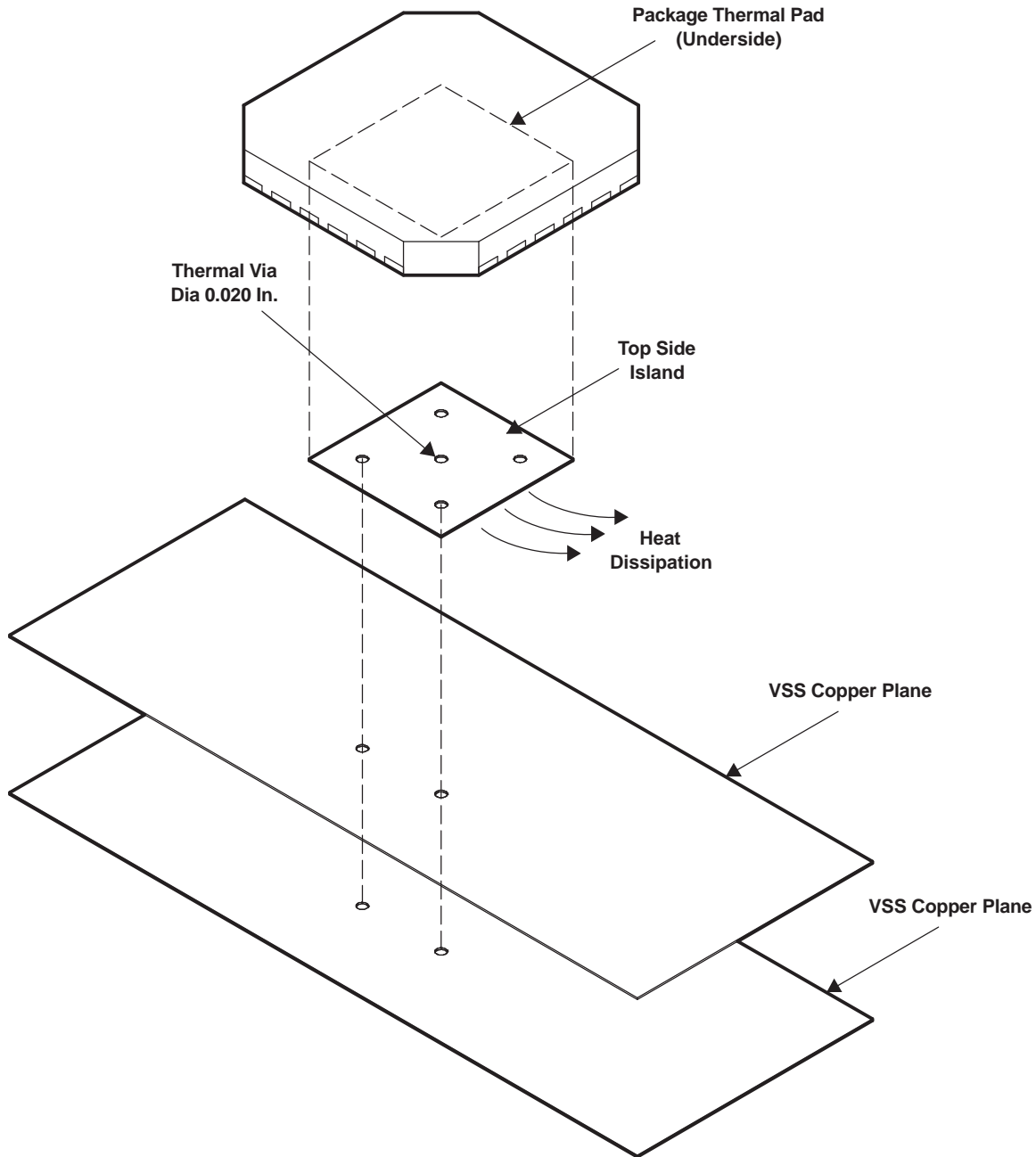

M0029-01

**Figure 9. Recommended Thermal Via Placement**

See the *Quad Flatpack No-Lead Logic Packages (SCBA017)* and *QFN/SON PCB Attachment (SLUA271)* application reports for further package-related information.

## APPLICATION INFORMATION

### LVPECL RECEIVER INPUT TERMINATION

The input of the CDCP1803 has a high impedance and comes with a large common-mode voltage range.

For optimized noise performance, it is recommended to properly terminate the PCB trace (transmission line). If a differential signal drives the CDCP1803, then a 100- $\Omega$  termination resistor is recommended to be placed as close as possible across the input terminals. An even better approach is to install  $2 \times 50\text{-}\Omega$  resistors, with the center tap connected to a capacitor (C) to terminate odd-mode noise and make up for transmission line mismatches. The VBB output can also be connected to the center tap to bias the input signal to  $(V_{DD} - 1.3\text{ V})$  (see Figure 10).

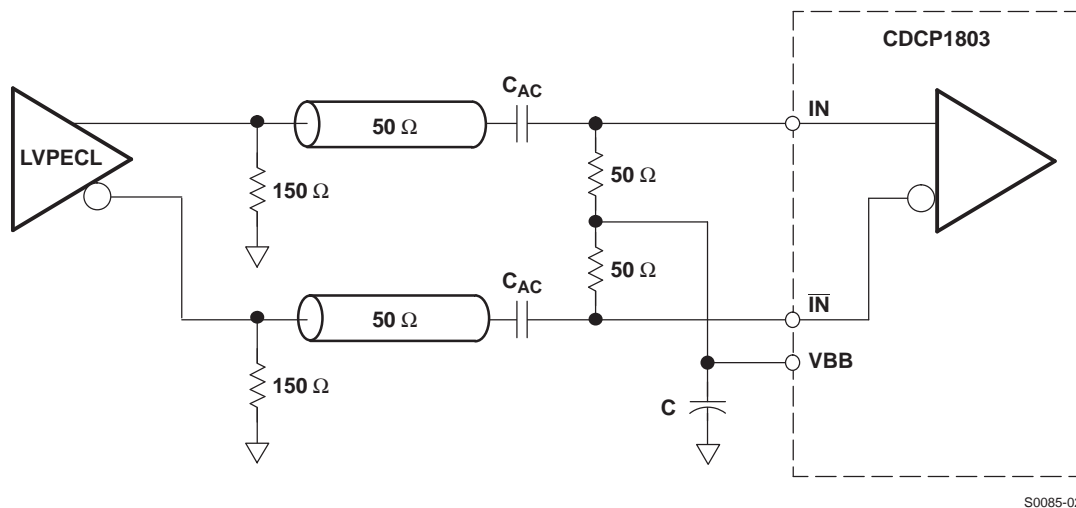

Figure 10. Recommended AC-Coupling LVPECL Receiver Input Termination

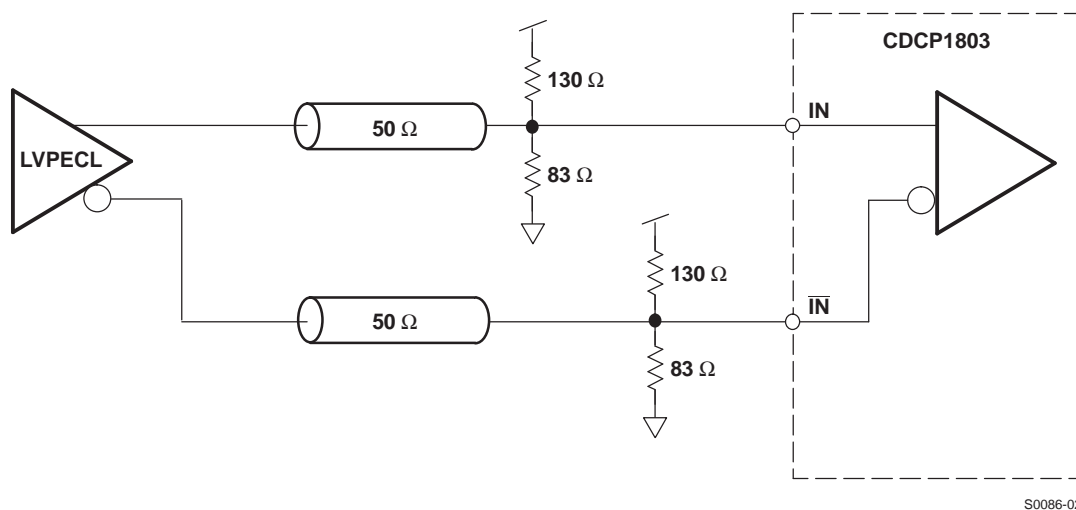
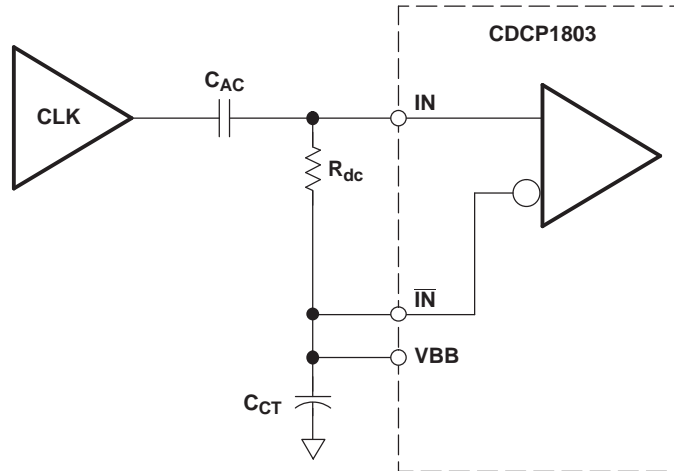

Figure 11. Recommended DC-Coupling LVPECL Receiver Input Termination

The CDCP1803 can also be driven by single-ended signals. Typically, the input signal becomes connected to one input, while the complementary input must be properly biased to the center voltage of the incoming input signal. For LVCMOS signals, this would be  $V_{CC}/2$ , realized by a simple voltage divider (e.g., two 10-k $\Omega$  resistors). The best option (especially if the dc offset of the input signal might vary) is to ac-couple the input signal and then rebias the signal using the VBB reference output. See Figure 12.



NOTE: C<sub>AC</sub> – AC-coupling capacitor (e.g., 10 nF)  
 C<sub>CT</sub> – Capacitor keeps voltage at  $\overline{IN}$  constant (e.g., 10 nF)  
 R<sub>dc</sub> – Load and correct duty cycle (e.g., 50  $\Omega$ )  
 VBB – Bias voltage output

S0087-02

Figure 12. Typical Application Setting for Single-Ended Input Signals Driving the CDCP1803

## DEVICE BEHAVIOR DURING RESET AND CONTROL-TERMINAL SWITCHING

### Output Behavior From Enabling the Device (EN = 0 → 1)

In disable mode (EN = 0), all output drivers are switched in high-Z mode. The S[2:0] control inputs are also switched off. In the same mode, all flip-flops are reset. The typical current consumption is below 500  $\mu$ A.

When the device is enabled again, it takes typically 1  $\mu$ s for the settling of the reference voltage and currents. During this time, the outputs Y[2:0] and  $\overline{Y}$ [2:0] drive a high signal. After the settle time, the outputs go into the low state. Due to the synchronization of each output driver signal with the input clock, the state of the waveforms after enabling the device is as shown in Figure 13. The inverting input and output signal is not included. The Y:/1 waveform is the undivided output driver state.

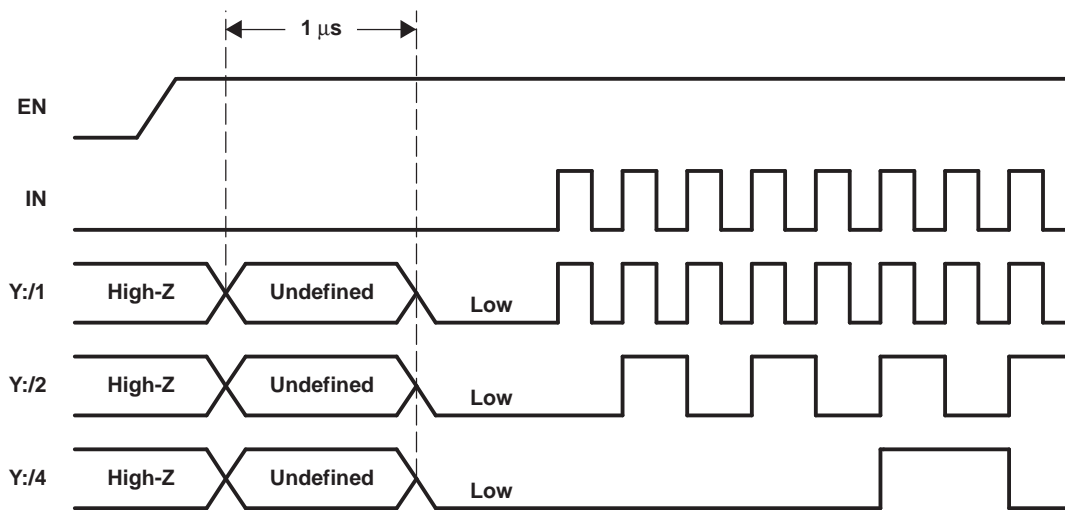

Signal State After the Device is Enabled (IN = Low)

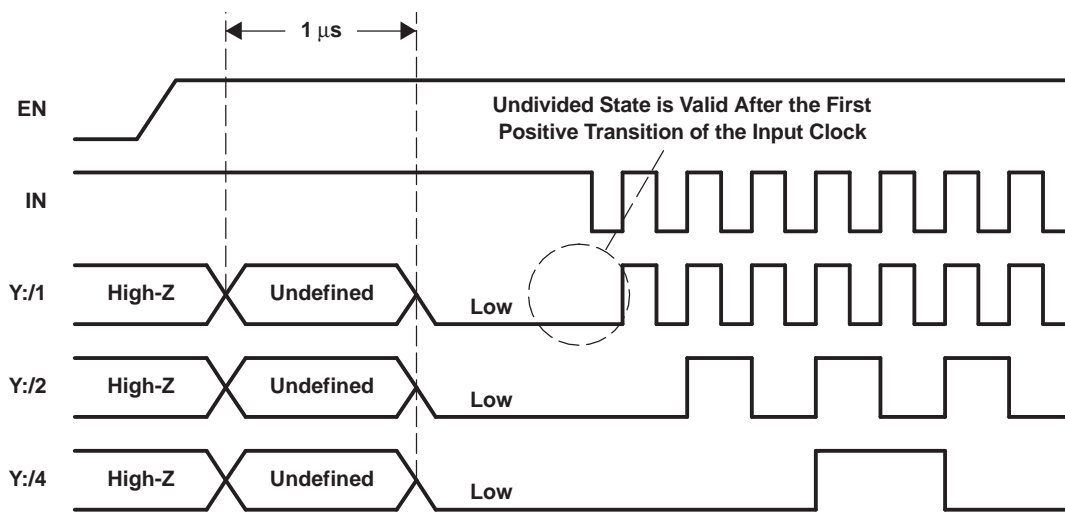

Signal State After the Device is Enabled (IN = High)

T0068-01

Figure 13. Waveforms

### Enabling a Single Output Stage

If a single output stage becomes enabled:

- $Y[2:0]$  is either low or high (undefined).
- $\overline{Y[2:0]}$  is the inverted signal of  $Y[2:0]$ .

With the first positive clock transition, the undivided output becomes the input clock state. The divided output states are equal to the actual internal divider. The internal divider is not reset while enabling single output drivers.

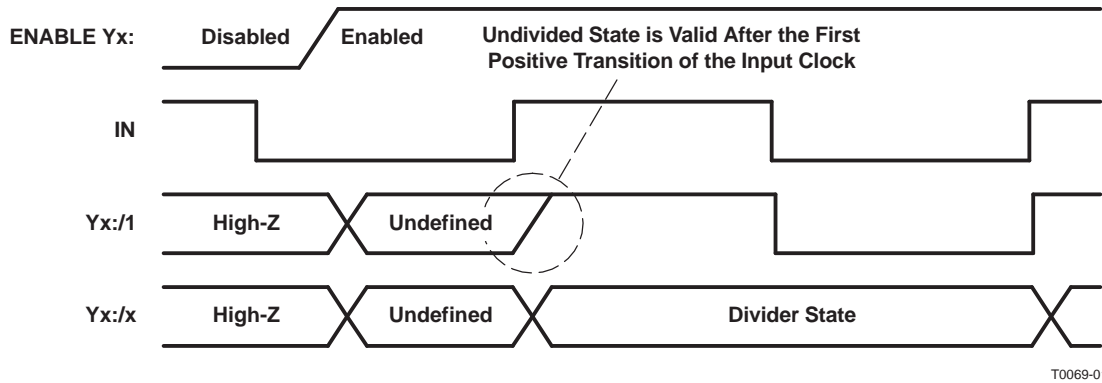

Figure 14. Signal State After an Output Driver Becomes Enabled While IN = 0

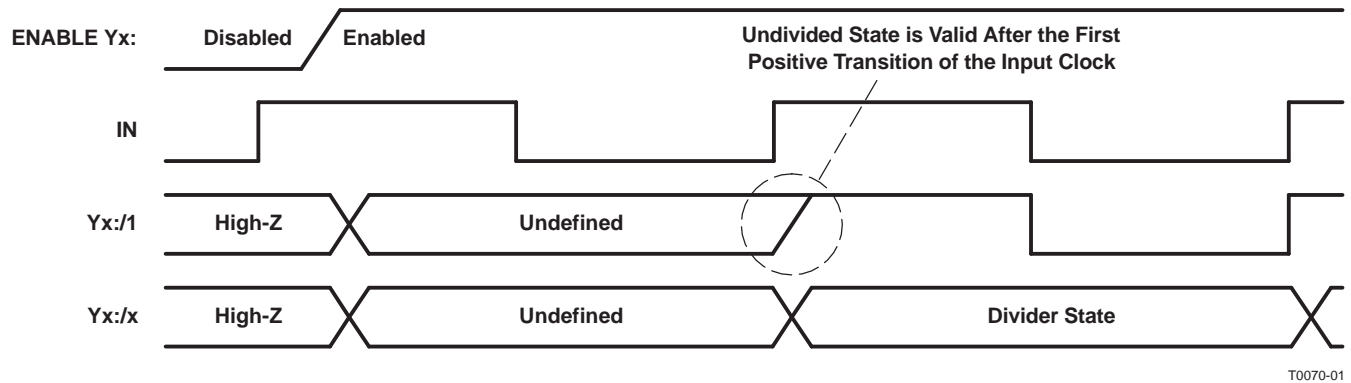

Figure 15. Signal State After an Output Driver Becomes Enabled While IN = 1

**PACKAGING INFORMATION**

Orderable Device	Status (1)	Package Type	Package Drawing	Pins	Package Qty	Eco Plan (2)	Lead/Ball Finish (6)	MSL Peak Temp (3)	Op Temp (°C)	Device Marking (4/5)	Samples
CDCP1803MRGETEP	LIFEBUY	VQFN	RGE	24		TBD	Call TI	Call TI	-55 to 125	CDCP 1803EP	
V62/09619-01XE	LIFEBUY	VQFN	RGE	24		TBD	Call TI	Call TI	-55 to 125	CDCP 1803EP	

(1) The marketing status values are defined as follows:

**ACTIVE:** Product device recommended for new designs.

**LIFEBUY:** TI has announced that the device will be discontinued, and a lifetime-buy period is in effect.

**NRND:** Not recommended for new designs. Device is in production to support existing customers, but TI does not recommend using this part in a new design.

**PREVIEW:** Device has been announced but is not in production. Samples may or may not be available.

**OBSOLETE:** TI has discontinued the production of the device.

(2) **RoHS:** TI defines "RoHS" to mean semiconductor products that are compliant with the current EU RoHS requirements for all 10 RoHS substances, including the requirement that RoHS substance do not exceed 0.1% by weight in homogeneous materials. Where designed to be soldered at high temperatures, "RoHS" products are suitable for use in specified lead-free processes. TI may reference these types of products as "Pb-Free".

**RoHS Exempt:** TI defines "RoHS Exempt" to mean products that contain lead but are compliant with EU RoHS pursuant to a specific EU RoHS exemption.

**Green:** TI defines "Green" to mean the content of Chlorine (Cl) and Bromine (Br) based flame retardants meet JS709B low halogen requirements of <=1000ppm threshold. Antimony trioxide based flame retardants must also meet the <=1000ppm threshold requirement.

(3) MSL, Peak Temp. - The Moisture Sensitivity Level rating according to the JEDEC industry standard classifications, and peak solder temperature.

(4) There may be additional marking, which relates to the logo, the lot trace code information, or the environmental category on the device.

(5) Multiple Device Markings will be inside parentheses. Only one Device Marking contained in parentheses and separated by a "~" will appear on a device. If a line is indented then it is a continuation of the previous line and the two combined represent the entire Device Marking for that device.

(6) Lead/Ball Finish - Orderable Devices may have multiple material finish options. Finish options are separated by a vertical ruled line. Lead/Ball Finish values may wrap to two lines if the finish value exceeds the maximum column width.

**Important Information and Disclaimer:**The information provided on this page represents TI's knowledge and belief as of the date that it is provided. TI bases its knowledge and belief on information provided by third parties, and makes no representation or warranty as to the accuracy of such information. Efforts are underway to better integrate information from third parties. TI has taken and continues to take reasonable steps to provide representative and accurate information but may not have conducted destructive testing or chemical analysis on incoming materials and chemicals. TI and TI suppliers consider certain information to be proprietary, and thus CAS numbers and other limited information may not be available for release.

In no event shall TI's liability arising out of such information exceed the total purchase price of the TI part(s) at issue in this document sold by TI to Customer on an annual basis.

**OTHER QUALIFIED VERSIONS OF CDCP1803-EP :**

- Catalog: [CDCP1803](#)

## NOTE: Qualified Version Definitions:

- Catalog - TI's standard catalog product

## GENERIC PACKAGE VIEW

RGE 24

VQFN - 1 mm max height

PLASTIC QUAD FLATPACK - NO LEAD

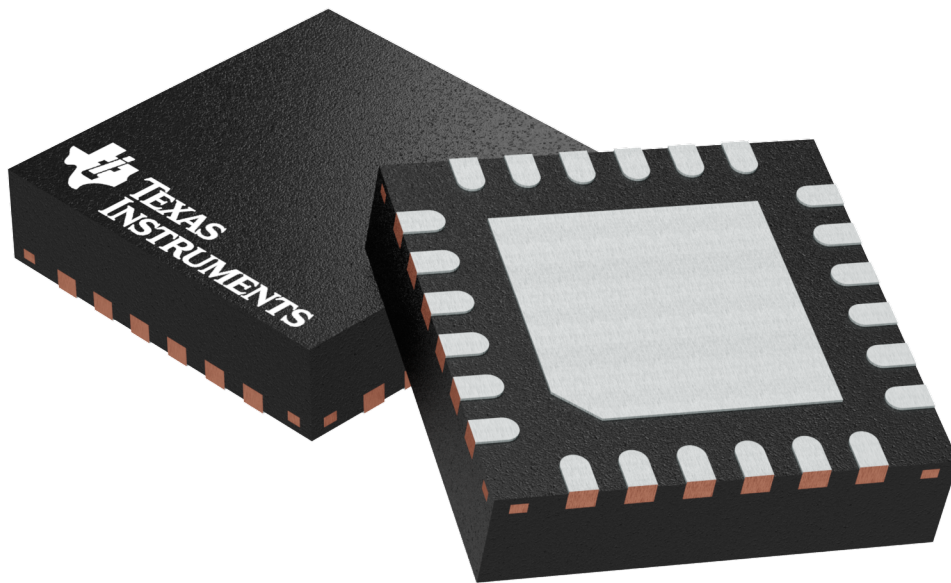

Images above are just a representation of the package family, actual package may vary.  
Refer to the product data sheet for package details.

4204104/H

## IMPORTANT NOTICE AND DISCLAIMER

TI PROVIDES TECHNICAL AND RELIABILITY DATA (INCLUDING DATASHEETS), DESIGN RESOURCES (INCLUDING REFERENCE DESIGNS), APPLICATION OR OTHER DESIGN ADVICE, WEB TOOLS, SAFETY INFORMATION, AND OTHER RESOURCES "AS IS" AND WITH ALL FAULTS, AND DISCLAIMS ALL WARRANTIES, EXPRESS AND IMPLIED, INCLUDING WITHOUT LIMITATION ANY IMPLIED WARRANTIES OF MERCHANTABILITY, FITNESS FOR A PARTICULAR PURPOSE OR NON-INFRINGEMENT OF THIRD PARTY INTELLECTUAL PROPERTY RIGHTS.

These resources are intended for skilled developers designing with TI products. You are solely responsible for (1) selecting the appropriate TI products for your application, (2) designing, validating and testing your application, and (3) ensuring your application meets applicable standards, and any other safety, security, or other requirements. These resources are subject to change without notice. TI grants you permission to use these resources only for development of an application that uses the TI products described in the resource. Other reproduction and display of these resources is prohibited. No license is granted to any other TI intellectual property right or to any third party intellectual property right. TI disclaims responsibility for, and you will fully indemnify TI and its representatives against, any claims, damages, costs, losses, and liabilities arising out of your use of these resources.

TI's products are provided subject to TI's Terms of Sale ([www.ti.com/legal/termsofsale.html](http://www.ti.com/legal/termsofsale.html)) or other applicable terms available either on [ti.com](http://ti.com) or provided in conjunction with such TI products. TI's provision of these resources does not expand or otherwise alter TI's applicable warranties or warranty disclaimers for TI products.

Mailing Address: Texas Instruments, Post Office Box 655303, Dallas, Texas 75265  
Copyright © 2019, Texas Instruments Incorporated

## Looking for pricing, stock, or lifecycle information?

Click below to explore more details on WIN SOURCE:

- ⊖ [View CDCP1803MRGETEP on WIN SOURCE](#)
- ⊖ [Texas Instruments](#) Information

## Optimize Your Supply Chain with WIN SOURCE Solutions

- ✓ Global Sourcing Solution
- ✓ Obsolete Management
- ✓ Cost Control Management
- ✓ Shortage Management
- ✓ Alternative Solution
- ✓ Excess Inventory Management