

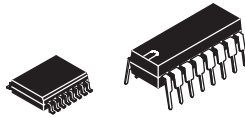

THE DATASHEET OF UCC2810DWTR





DUAL CHANNEL SYNCHRONIZED CURRENT-MODE PWM

FEATURES

- Single Oscillator Synchronizes Two PWMs
- 150- μ A Startup Supply Current
- 2-mA Operating Supply Current
- Operation to 1 MHz
- Internal Soft-Start
- Full-Cycle Fault Restart
- Internal Leading-Edge Blanking of the Current Sense Signal
- 1-A Totem Pole Outputs
- 75-ns Typical Response from Current Sense to Output
- 1.5% Tolerance Voltage Reference

DESCRIPTION

The UCC3810 is a high-speed BiCMOS controller integrating two synchronized pulse width modulators for use in off-line and dc-to-dc power supplies. The UCC3810 family provides perfect synchronization between two PWMs by using the same oscillator. The oscillator's sawtooth waveform can be used for slope compensation if required.

Using a toggle flip-flop to alternate between modulators, the UCC3810 ensures that one PWM does not slave, interfere, or otherwise affect the other PWM. This toggle flip-flop also ensures that each PWM is limited to 50% maximum duty cycle, insuring adequate off-time to reset magnetic elements. This device contains many of the same elements of the UC3842 current mode controller family, combined with the enhancements of the UCC3802. This minimizes power supply parts count. Enhancements include leading edge blanking of the current sense signals, full cycle fault restart, CMOS output drivers, and outputs which remain low even when the supply voltage is removed.

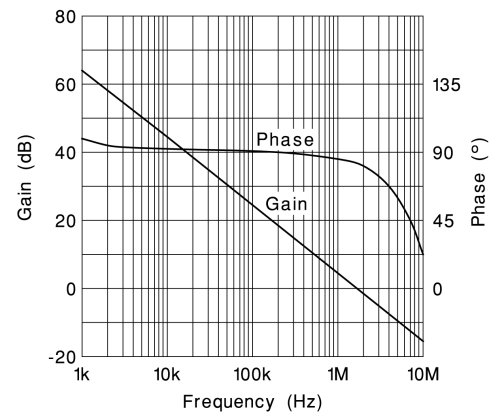
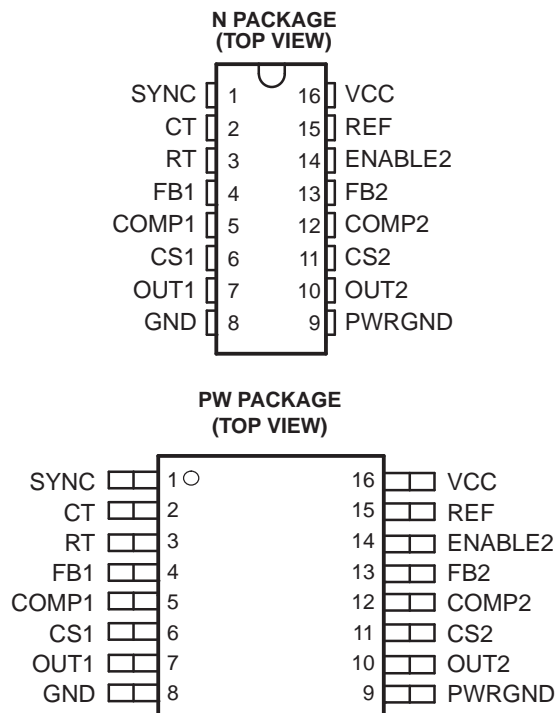

Please be aware that an important notice concerning availability, standard warranty, and use in critical applications of Texas Instruments semiconductor products and disclaimers thereto appears at the end of this data sheet.



These devices have limited built-in ESD protection. The leads should be shorted together or the device placed in conductive foam during storage or handling to prevent electrostatic damage to the MOS gates.

ORDERING INFORMATION

T _J	PACKAGED DEVICES ⁽¹⁾	
	SOP (DW)	PDIP (N)
-40°C to 85°C	UCC2810DW (16)	UCC2810N (16)
0°C to 70°C	UCC3810DW (16)	UCC3810N (16)

(1) All packages are available taped and reeled (indicated by the R suffix on the device type e.g., UCC2810JR)

ABSOLUTE MAXIMUM RATINGS

over operating free-air temperature range (unless otherwise noted)⁽¹⁾⁽²⁾

		UNIT
V _{CC}	Supply voltage ⁽³⁾	11V
I _{CC}	Supply current	20mA
	Output peak current, OUT1, OUT2, 5% duty cycle	±1A
	Output energy, OUT1, OUT2, capacitive load 20 μJ	20μJ
	Analog inputs, FB1, FB2, CS1, CS2, SYNC	-0.3 to 6.3V
T _J	Operating junction temperature	150°C
T _{stg}	Storage temperature range	-65 to 150°C
	Lead temperature (soldering, 10 sec)	300°C

- (1) Currents are positive into, negative out of the specified terminal. All voltages are with respect to GND.
- (2) Stresses beyond those listed under absolute maximum ratings may cause permanent damage to the device. These are stress ratings only, and functional operation of the device at these or any other conditions beyond those indicated under recommended operating conditions is not implied. Exposure to absolute-maximum-rated conditions for extended periods may affect device reliability.
- (3) In normal operation, V_{CC} is powered through a current-limiting resistor. Absolute maximum of 11 V applies when driven from a low impedance such that the V_{CC} current does not exceed 20 mA.

BLOCK DIAGRAM

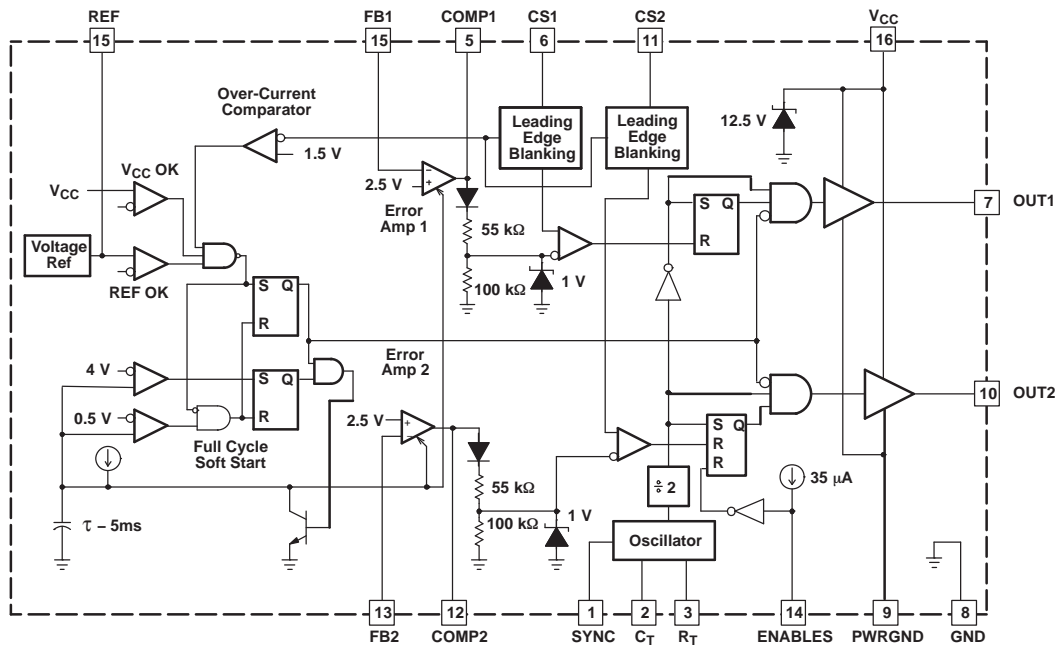

VDG-92062-1

ELECTRICAL CHARACTERISTICS

All parameters are the same for both channels, $-40^{\circ}\text{C} \leq T_A \leq 85^{\circ}\text{C}$ for the UCC2810, $0^{\circ}\text{C} \leq T_A \leq 70^{\circ}\text{C}$ for the UCC3810, $V_{CC} = 10\text{ V}^{(1)}$; $R_T = 150\text{ k}\Omega$, $C_T = 120\text{ pF}$; no load; $T_A = T_J$; (unless otherwise specified)

PARAMETER		TEST CONDITIONS	MIN	TYP	MAX	UNIT
REFERENCE						
V_{CC}	Output voltage	$T_J = 25^{\circ}\text{C}$	4.925	5.000	5.075	V
		$T_J = \text{full range, } 0\text{ mA} \leq I_{REF} \leq 5\text{ mA}$	4.85	5.00	5.10	
	Load regulation	$0\text{ mA} \leq I_{REF} \leq 5\text{ mA}$		5	30	mV
	Line regulation	UVLO stop threshold voltage, $0.5\text{ V} \leq V_{CC} \leq V_{SHUNT}$		12		
	Output noise voltage ⁽²⁾	10Hz <f< 10 kHz, $T_J = 25^{\circ}\text{C}$		235		
	Long term stability ⁽²⁾	$T_A = 125^{\circ}\text{C}$, 1000 hours		5		mV
$I_{O(SC)}$	Output short circuit current			-8	-25	mA
OSCILLATOR						
f_{OSC}	Oscillator frequency ⁽³⁾	$R_T = 30\text{ k}\Omega$, $C_T = 120\text{ pF}$	860	980	1100	kHz
		$R_T = 150\text{ k}\Omega$, $C_T = 120\text{ pF}$	190	220	250	
	Temperature stability ⁽²⁾			2.5%		V
	Peak voltage			2.5		
	Valley voltage			0.05		
	Peak-to-peak amplitude		2.25	2.45	2.65	
	SYNC threshold voltage		0.80	1.65	2.20	
	SYNC input current	SYNC = 5 V		30		
ERROR AMPLIFIER						
V_{FB}	FB input voltage	COMP = 2.5 V	2.44	2.50	2.56	V
I_{FB}	FB input bias current				± 1	μA
	Open loop voltage gain		60	73		dB
f_{GAIN}	Unity gain bandwidth ⁽²⁾			2		MHz
I_{SINK}	Sink current, COMP	FB = 2.7 V, COMP = 1 V	0.3	1.4	3.5	
I_{SRCE}	Source current, COMP	FB = 1.8 V, COMP = 4 V	-0.2	-0.5	-0.8	mA
	Minimum duty cycle	COMP = 0 V			0%	
	Soft-start rise time, COMP	FB = 1.8 V, Rise from 0.5 V to (REF - 1.5 V)			5	ms
CURRENT SENSE						
	Gain ⁽⁴⁾		1.20	1.55	1.80	V/V
	Maximum input signal ⁽⁵⁾	COMP = 5 V	0.9	1.0	1.1	V
I_{CS}	Input bias current, CS				± 200	nA
	Propagation delay time (CS to OUT)	CS steps from 0 V to 1.2 V, COMP = 2.5 V		75		ns
	Blank time, CS ⁽⁶⁾			55		
	Overcurrent threshold voltage, CS		1.35	1.55	1.85	V
	COMP-to-CS offset voltage	CS = 0 V	0.45	0.90	1.35	

(1) For UCC3810, adjust V_{CC} above the start threshold before setting at 10 V.

(2) Ensured by design. Not production tested.

$$f_{OSC} = \frac{4}{R_T \times C_T}$$

(3) Oscillator frequency is twice the output frequency.

$$A = \frac{\Delta V_{COMP}}{\Delta V_{CS}}$$

(4) Current sense gain A is defined by: $0\text{ V} \leq V_{CS} \leq 0.8\text{ V}$.

(5) Parameter measured at trip point of latch with FB = 0 V.

(6) CS blank time is measured as the difference between the minimum non-zero on-time and the CS-to-OUT delay.

ELECTRICAL CHARACTERISTICS (continued)

All parameters are the same for both channels, $-40^{\circ}\text{C} \leq T_A \leq 85^{\circ}\text{C}$ for the UCC2810, $0^{\circ}\text{C} \leq T_A \leq 70^{\circ}\text{C}$ for the UCC3810, $V_{CC} = 10\text{ V}$; $R_T = 150\text{ k}\Omega$, $C_T = 120\text{ pF}$; no load; $T_A = T_J$; (unless otherwise specified)

PARAMETER		TEST CONDITIONS	MIN	TYP	MAX	UNIT
PWM						
Maximum duty cycle ⁽²⁾		$R_T = 150\text{ k}\Omega$, $C_T = 120\text{ pF}$	45%	49%	50%	
		$R_T = 30\text{ k}\Omega$, $C_T = 120\text{ pF}$	40%	45%	48%	
Minimum on-time		$CS = 1.2\text{ V}$, $COMP = 5\text{ V}$		130		ns
OUTPUT						
V_{OL} Low-level output voltage		$I_{OUT} = 20\text{ mA}$		0.12	0.42	V
		$I_{OUT} = 200\text{ mA}$		0.48	1.10	
		$I_{OUT} = 20\text{ mA}$, $V_{CC} = 0\text{ V}$		0.7	1.2	
V_{OH} High-level output voltage ($V_{CC} - OUT$)		$I_{OUT} = -20\text{ mA}$		0.15	0.42	V
		$I_{OUT} = -200\text{ mA}$		1.2	2.3	
t_R Rise time, OUT		$C_{OUT} = 1\text{ nF}$		20	50	ns
t_F Fall time, OUT		$C_{OUT} = 1\text{ nF}$		30	60	
UNDERVOLTAGE LOCKOUT (UVLO)						
Start threshold voltage			9.6	11.3	13.2	V
Stop threshold voltage			7.1	8.3	9.5	
Start-to-stop hysteresis			1.7	3.0	4.7	
ENABLE2 input bias current		$ENABLE2 = 0\text{ V}$	-20	-35	-55	μA
ENABLE2 input threshold voltage			0.80	1.53	2.00	V
OVERALL						
Startup current		$V_{CC} < \text{Start threshold voltage}$		0.15	0.25	mA
Operating supply current, outputs off		$V_{CC} = 10\text{ V}$, $FB = 2.75\text{ V}$		2	3	
Operating supply current, outputs on		$V_{CC} = 10\text{ V}$, $CS = 0\text{ V}$, $FB = 0\text{ V}$, $RT = 150\text{ k}\Omega$		3.2	5.1	
		$V_{CC} = 10\text{ V}$, $CS = 0\text{ V}$, $FB = 0\text{ V}$, $RT = 30\text{ k}\Omega$		8.5	14.5	
VCC internal zener voltage		$I_{CC} = 10\text{ mA}$	11.0	12.9	14.0	V
VCC internal zener voltage minus start threshold voltage			0.4	1.2		

DEVICE INFORMATION
TERMINAL FUNCTIONS

TERMINAL		I/O	DESCRIPTION
NAME	NO.		
COMP1	5	O	Low impedance output of the error amplifiers.
COMP2	12	O	
CS1	6	I	Current sense inputs to the PWM comparators. These inputs have leading edge blanking. For most applications, no input filtering is required. Leading edge blanking disconnects the CS inputs from all internal circuits for the first 55 ns of each PWM cycle. When used with very slow diodes or in other applications where the current sense signal is unusually noisy, a small current-sense R-C filter may be required.
CS2	11	I	
CT	2	O	The timing capacitor of the oscillator. Recommended values of CT are between 100 pF and 1 nF. Connect the timing capacitor directly across CT and GND.
ENABLE2	14	I	A logic input which disables PWM 2 when low. This input has no effect on PWM 1. This input is internally pulled high. In most applications it can be left floating. In unusually noisy applications, the input should be bypassed with a 1-nF ceramic capacitor. This input has TTL compatible thresholds.
FB1	4	I	The high impedance inverting inputs of the error amplifiers.
FB2	13	I	
GND	8	–	To separate noise from the critical control circuits, this part has two different ground connections: GND and PWRGND. GND and PWRGND must be electrically connected together. However, use care to avoid coupling noise into GND.
OUT1	7	O	The high-current push-pull outputs of the PWM are intended to drive power MOSFET gates through a small resistor. This resistor acts as both a current limiting resistor and as a damping impedance to minimize ringing and overshoot.
OUT2	10	O	
PWRGND	9	–	To separate noise from the critical control circuits, this part has two different ground connections: GND and PWRGND. GND and PWRGND must be electrically connected together.
REF	15	O	The output of the 5-V reference. Bypass REF to GND with a ceramic capacitor $\geq 0.01\text{-}\mu\text{F}$ for best performance.
RT	3	O	The oscillator charging current is set by the value of the resistor connected from RT to GND. This pin is regulated to 1 V, but the actual charging current is $10\text{ V}/\text{RT}$. Recommended values of RT are between 10 k Ω and 470 k Ω . For a given frequency, higher timing resistors give higher maximum duty cycle and slightly lower overall power consumption.
SYNC	1	I	This logic input can be used to synchronize the oscillator to a free running oscillator in another part. This pin is edge triggered with TTL thresholds, and requires at least a 10-ns-wide pulse. If unused, this pin can be grounded, open circuited, or connected to REF.
VCC	16	I	The power input to the device. This pin supplies current to all functions including the high current output stages and the precision reference. Therefore, it is critical that VCC be directly bypassed to PWRGND with an 0.1- μF ceramic capacitor.

APPLICATION INFORMATION

TIMING RESISTOR

Supply current decreases with increased R_T by the relationship:

$$\Delta I_{CC} = \frac{11V}{R_T}$$

For more information, see the detailed oscillator block diagram.

LEADING EDGE BLANKING AND CURRENT SENSE

Figure 1 shows how an external power stage is connected to the UCC3810. The gate of an external power N-channel MOSFET is connected to OUT through a small current-limiting resistor. For most applications, a 10- Ω resistor is adequate to limit peak current and also practical at damping resonances between the gate driver and the MOSFET input reactance. Long gate lead length increases gate capacitance and mandates a higher series gate resistor to damp the R-L-C tank formed by the lead, the MOSFET input reactance, and the device's driver output resistance.

The UCC3810 features internal leading edge blanking of the current-sense signal on both current sense inputs. The blank time starts when OUT rises and continues for 55 ns. During that 55 ns period, the signal on CS is ignored. For most PWM applications, this means that the CS input can be connected to the current-sense resistor as shown in Figure 1. However, high speed grounding practices and short lead lengths are still required for good performance.

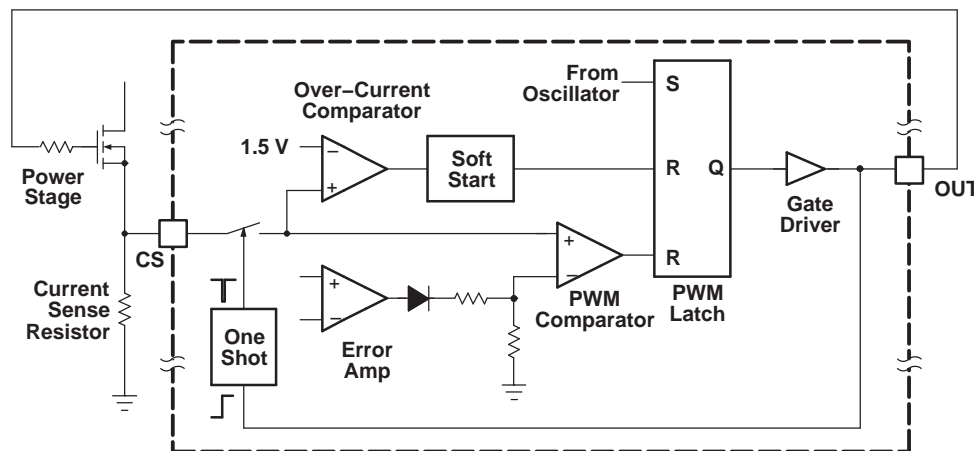

Figure 1. Detailed Block Diagram

OSCILLATOR

The UCC3810 oscillator generates a sawtooth wave at CT. The sawtooth rise time is set by the resistor from R_T to GND. Since R_T is biased at 1 V, the current through R_T is $1 V/R_T$. The actual charging current is 10 times higher. The fall time is set by an internal transistor on-resistance of approximately 100 Ω . During the fall time, all outputs are off and the maximum duty cycle is reduced to below 50%. Larger timing capacitors increase the discharge time and reduce frequency. However, the percentage maximum duty cycle is only a function of the timing resistor R_T , and the internal 100- Ω discharge resistance.

ERROR AMPLIFIER OUTPUT STAGE

The UCC3810 error amplifiers are operational amplifiers with low-output resistance and high-input resistance. The output stage of one error amplifier is shown in Figure 3. This output stage allows the error amplifier output to swing close to GND and as high as one diode drop below 5 V with little loss in amplifier performance.

APPLICATION INFORMATION (continued)

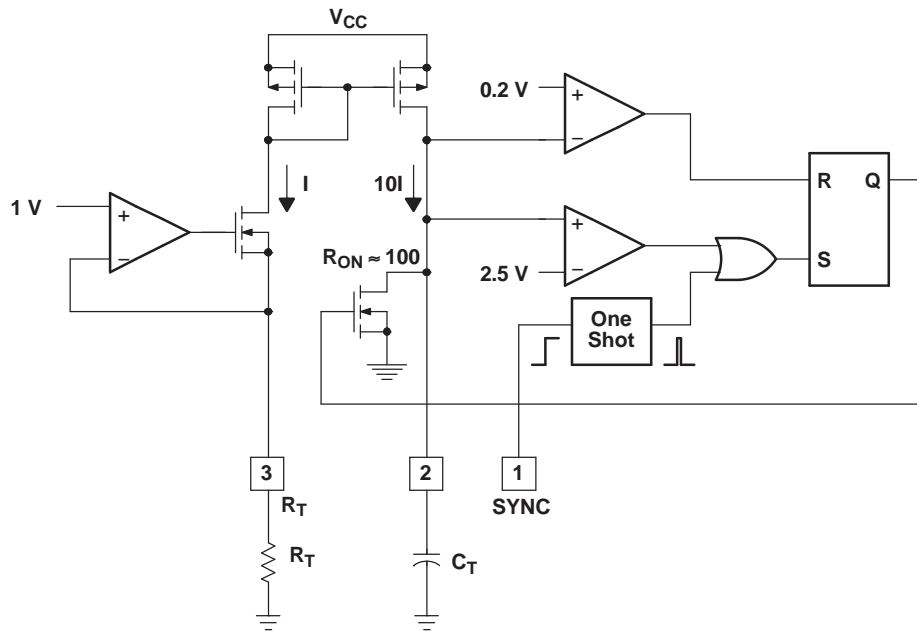

Figure 2. Oscillator

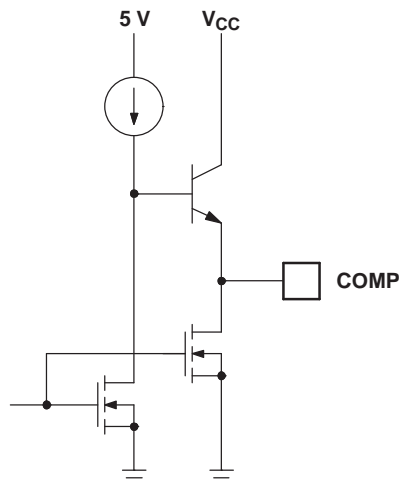

Figure 3. Error Amplifier Output Stage

TYPICAL CHARACTERISTICS

ERROR AMPLIFIER GAIN AND PHASE
VS
FREQUENCY

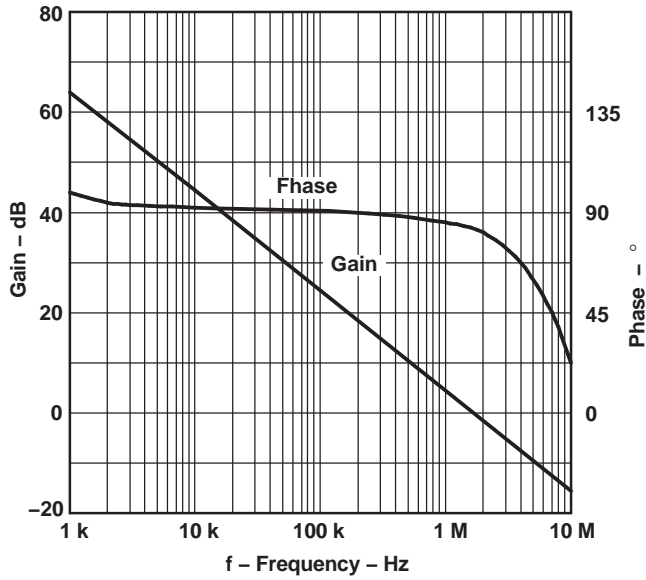

Figure 4.

OSCILLATOR FREQUENCY
VS
TIMING RESISTANCE

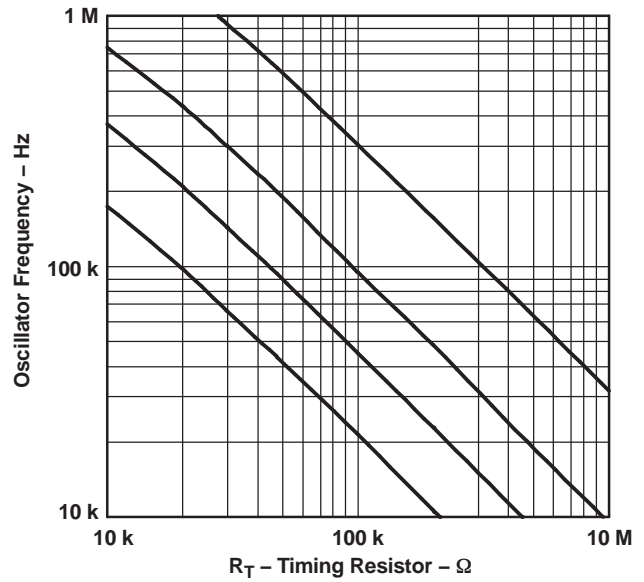

Figure 5.

OSCILLATOR FREQUENCY
VS
TEMPERATURE

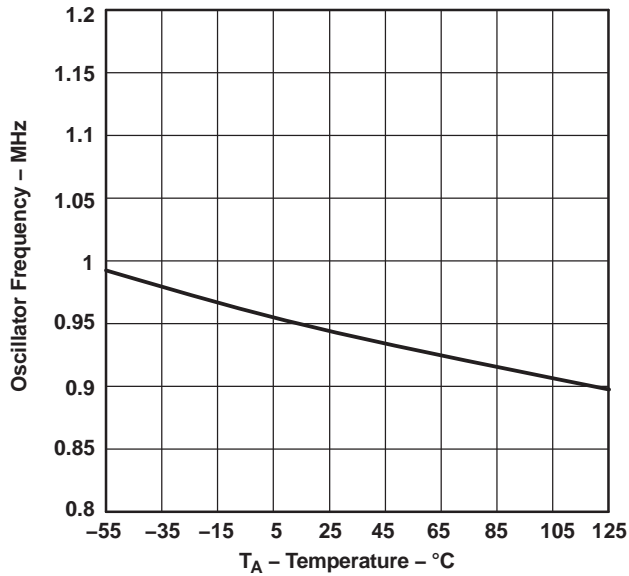

Figure 6.

MAXIMUM DUTY CYCLE
VS
TIMING RESISTANCE

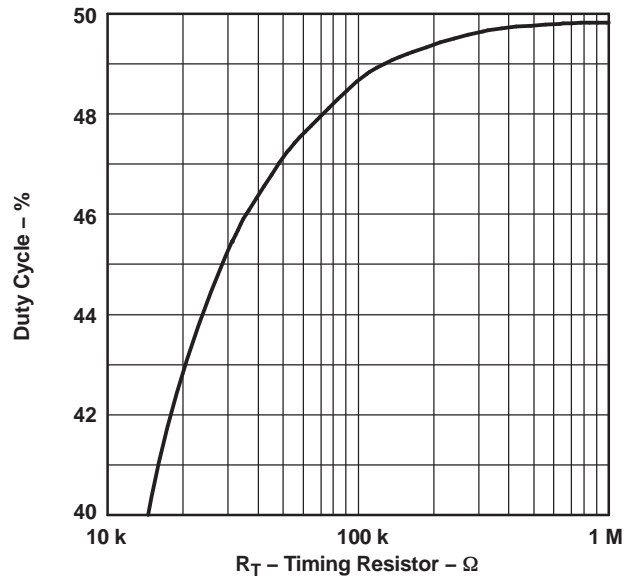

Figure 7.

TYPICAL CHARACTERISTICS (continued)

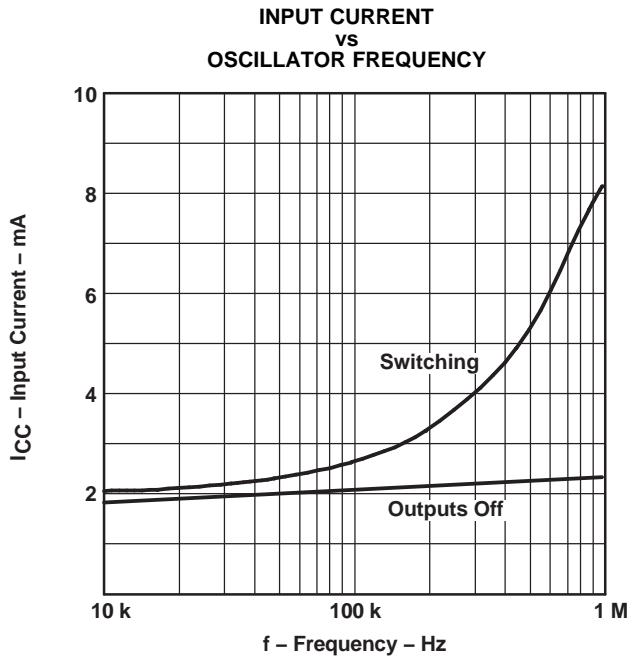

Figure 8.

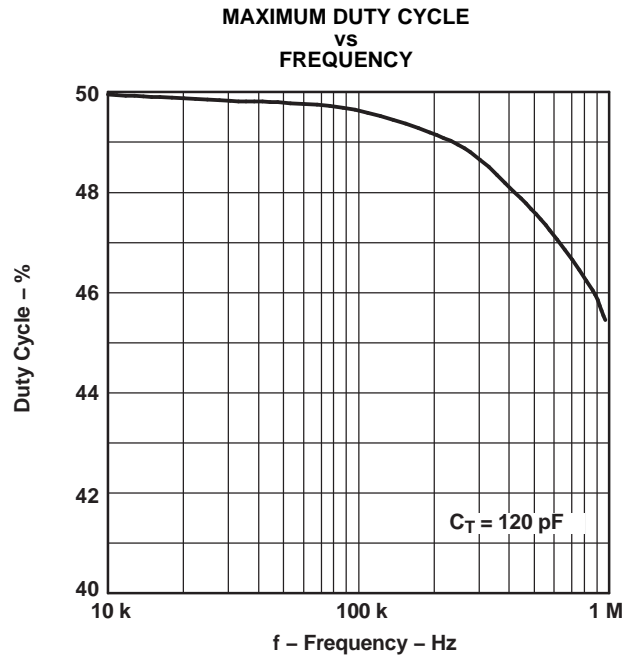
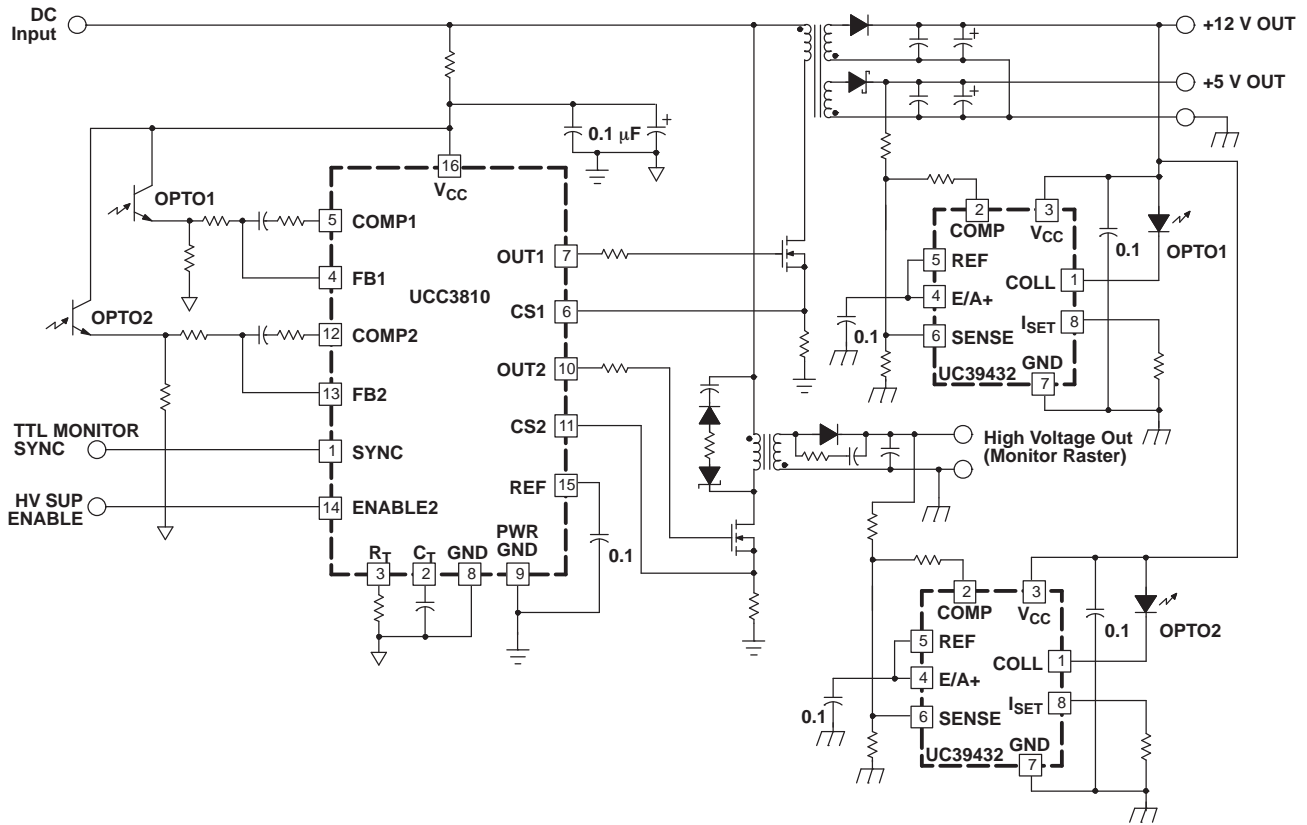
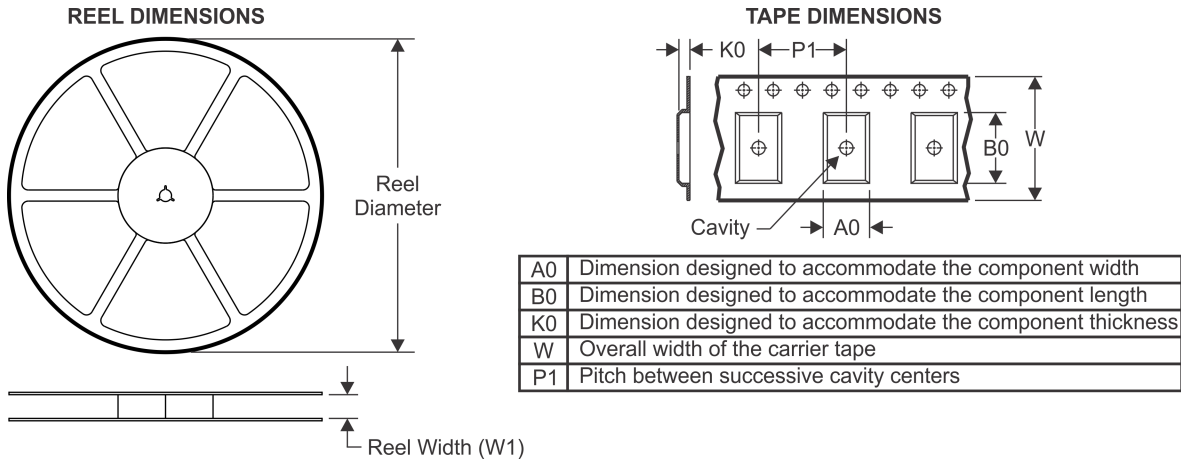
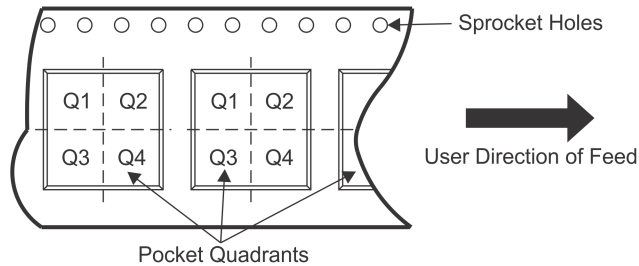

Figure 9.



VDG-94022

Figure 10. Typical Application

TAPE AND REEL INFORMATION

QUADRANT ASSIGNMENTS FOR PIN 1 ORIENTATION IN TAPE

*All dimensions are nominal

Device	Package Type	Package Drawing	Pins	SPQ	Reel Diameter (mm)	Reel Width W1 (mm)	A0 (mm)	B0 (mm)	K0 (mm)	P1 (mm)	W (mm)	Pin1 Quadrant
UCC3810DWTR	SOIC	DW	16	2000	330.0	16.4	10.75	10.7	2.7	12.0	16.0	Q1

TAPE AND REEL BOX DIMENSIONS



*All dimensions are nominal

Device	Package Type	Package Drawing	Pins	SPQ	Length (mm)	Width (mm)	Height (mm)
UCC3810DWTR	SOIC	DW	16	2000	367.0	367.0	38.0

IMPORTANT NOTICE

Texas Instruments Incorporated and its subsidiaries (TI) reserve the right to make corrections, enhancements, improvements and other changes to its semiconductor products and services per JESD46, latest issue, and to discontinue any product or service per JESD48, latest issue. Buyers should obtain the latest relevant information before placing orders and should verify that such information is current and complete. All semiconductor products (also referred to herein as "components") are sold subject to TI's terms and conditions of sale supplied at the time of order acknowledgment.

TI warrants performance of its components to the specifications applicable at the time of sale, in accordance with the warranty in TI's terms and conditions of sale of semiconductor products. Testing and other quality control techniques are used to the extent TI deems necessary to support this warranty. Except where mandated by applicable law, testing of all parameters of each component is not necessarily performed.

TI assumes no liability for applications assistance or the design of Buyers' products. Buyers are responsible for their products and applications using TI components. To minimize the risks associated with Buyers' products and applications, Buyers should provide adequate design and operating safeguards.

TI does not warrant or represent that any license, either express or implied, is granted under any patent right, copyright, mask work right, or other intellectual property right relating to any combination, machine, or process in which TI components or services are used. Information published by TI regarding third-party products or services does not constitute a license to use such products or services or a warranty or endorsement thereof. Use of such information may require a license from a third party under the patents or other intellectual property of the third party, or a license from TI under the patents or other intellectual property of TI.

Reproduction of significant portions of TI information in TI data books or data sheets is permissible only if reproduction is without alteration and is accompanied by all associated warranties, conditions, limitations, and notices. TI is not responsible or liable for such altered documentation. Information of third parties may be subject to additional restrictions.

Resale of TI components or services with statements different from or beyond the parameters stated by TI for that component or service voids all express and any implied warranties for the associated TI component or service and is an unfair and deceptive business practice. TI is not responsible or liable for any such statements.

Buyer acknowledges and agrees that it is solely responsible for compliance with all legal, regulatory and safety-related requirements concerning its products, and any use of TI components in its applications, notwithstanding any applications-related information or support that may be provided by TI. Buyer represents and agrees that it has all the necessary expertise to create and implement safeguards which anticipate dangerous consequences of failures, monitor failures and their consequences, lessen the likelihood of failures that might cause harm and take appropriate remedial actions. Buyer will fully indemnify TI and its representatives against any damages arising out of the use of any TI components in safety-critical applications.

In some cases, TI components may be promoted specifically to facilitate safety-related applications. With such components, TI's goal is to help enable customers to design and create their own end-product solutions that meet applicable functional safety standards and requirements. Nonetheless, such components are subject to these terms.

No TI components are authorized for use in FDA Class III (or similar life-critical medical equipment) unless authorized officers of the parties have executed a special agreement specifically governing such use.

Only those TI components which TI has specifically designated as military grade or "enhanced plastic" are designed and intended for use in military/aerospace applications or environments. Buyer acknowledges and agrees that any military or aerospace use of TI components which have **not** been so designated is solely at the Buyer's risk, and that Buyer is solely responsible for compliance with all legal and regulatory requirements in connection with such use.

TI has specifically designated certain components as meeting ISO/TS16949 requirements, mainly for automotive use. In any case of use of non-designated products, TI will not be responsible for any failure to meet ISO/TS16949.

Products

Audio	www.ti.com/audio
Amplifiers	amplifier.ti.com
Data Converters	dataconverter.ti.com
DLP® Products	www.dlp.com
DSP	dsp.ti.com
Clocks and Timers	www.ti.com/clocks
Interface	interface.ti.com
Logic	logic.ti.com
Power Mgmt	power.ti.com
Microcontrollers	microcontroller.ti.com
RFID	www.ti-rfid.com
OMAP Applications Processors	www.ti.com/omap
Wireless Connectivity	www.ti.com/wirelessconnectivity

Applications

Automotive and Transportation	www.ti.com/automotive
Communications and Telecom	www.ti.com/communications
Computers and Peripherals	www.ti.com/computers
Consumer Electronics	www.ti.com/consumer-apps
Energy and Lighting	www.ti.com/energy
Industrial	www.ti.com/industrial
Medical	www.ti.com/medical
Security	www.ti.com/security
Space, Avionics and Defense	www.ti.com/space-avionics-defense
Video and Imaging	www.ti.com/video

TI E2E Community

e2e.ti.com

Looking for pricing, stock, or lifecycle information?

Click below to explore more details on WIN SOURCE:

 [View UCC2810DWTR](#) on WIN SOURCE

 [Texas Instruments](#) Information

Optimize Your Supply Chain with WIN SOURCE Solutions

-  Global Sourcing Solution
-  Obsolete Management
-  Cost Control Management
-  Shortage Management
-  Alternative Solution
-  Excess Inventory Management