



THE DATASHEET OF BUV48A



High voltage fast switching NPN power transistor

Features

- High current capability
- Fast switching speed

Applications

- Switching mode power supplies
- Flyback and forward single transistor low power converter

Description

The device is a multiepitaxial mesa NPN transistor mounted in TO-247 plastic package. It is intended for switching and industrial applications from single and three-phase mains.

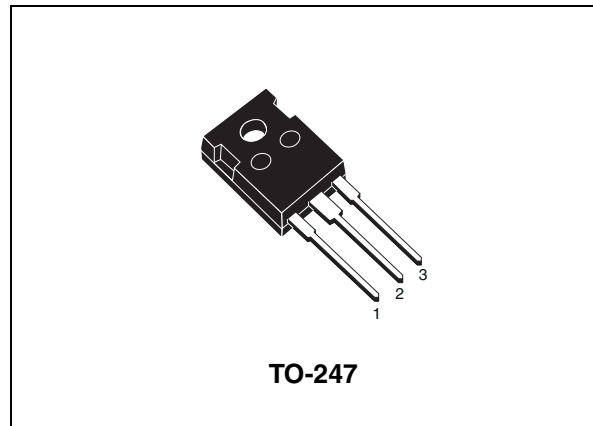

Figure 1. Internal schematic diagram

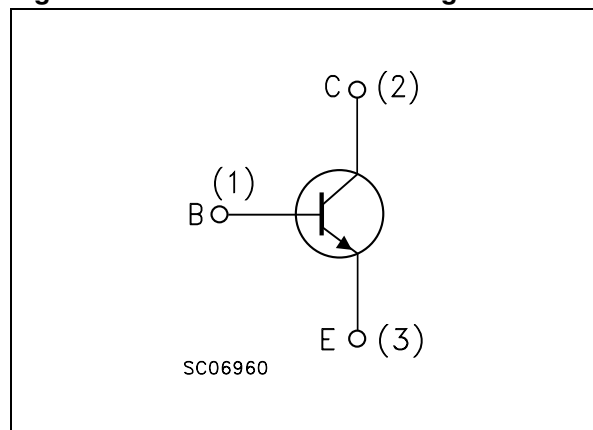

Table 1. Device summary

Order code	Marking	Package	Packaging
BUV48A	BUV48A	TO-247	Tube

1 Absolute maximum ratings

Table 2. Absolute maximum ratings

Symbol	Parameter	Value	Unit
V_{CER}	Collector-emitter voltage ($R_{BE} = 10 \Omega$)	1000	V
V_{CES}	Collector-emitter voltage ($V_{BE} = 0$)	1000	V
V_{CEO}	Collector-emitter voltage ($I_B = 0$)	450	V
V_{EBO}	Emitter-base voltage ($I_C = 0$)	7	V
I_C	Collector current	15	A
I_{CM}	Collector peak current	30	A
I_{CP}	Collector peak current non repetitive ($t_p < 20 \mu s$)	55	A
I_B	Base current	4	A
I_{BM}	Base peak current	20	A
P_{TOT}	Total dissipation at $T_{case} = 25 \text{ }^\circ\text{C}$	125	W
T_{STG}	Storage temperature	-65 to 150	$^\circ\text{C}$
T_J	Max. operating junction temperature	150	$^\circ\text{C}$

Table 3. Thermal data

Symbol	Parameter	Value	Unit
R_{thJC}	Thermal resistance junction-case max	1	$^\circ\text{C}/\text{W}$

2 Electrical characteristics

$T_{case} = 25\text{ °C}$; unless otherwise specified.

Table 4. Electrical characteristics

Symbol	Parameter	Test conditions	Min.	Typ.	Max.	Unit
I_{CES}	Collector cut-off current ($V_{BE} = 0$)	$V_{CE} = 1000\text{ V}$ $V_{CE} = 1000\text{ V}$ $T_c = 125\text{ °C}$			200 2	μA mA
I_{CER}	Collector cut-off current ($R_{BE} = 10\Omega$)	$V_{CE} = 1000\text{ V}$ $V_{CE} = 1000\text{ V}$ $T_c = 125\text{ °C}$			500 4	μA mA
I_{EBO}	Emitter cut-off current ($I_C = 0$)	$V_{EB} = 5\text{ V}$			1	mA
$V_{CEO(sus)}^{(1)}$	Collector-emitter sustaining voltage ($I_B = 0$)	$I_C = 200\text{ mA}$	450			V
V_{EBO}	Emitter-base voltage ($I_C = 0$)	$I_E = 50\text{ mA}$	7		30	V
$V_{CE(sat)}^{(1)}$	Collector-emitter saturation voltage	$I_C = 8\text{ A}$ $I_B = 1.6\text{ A}$ $I_C = 12\text{ A}$ $I_B = 2.4\text{ A}$			1.5 5	V V
$V_{BE(sat)}^{(1)}$	Base-emitter saturation voltage	$I_C = 8\text{ A}$ $I_B = 1.6\text{ A}$			1.6	V
$h_{FE}^{(1)}$	DC current gain	$I_C = 8\text{ A}$ $V_{CE} = 5\text{ V}$	8			
t_{on} t_s t_f	Resistive load Turn-on time Storage time Fall time	$V_{CC} = 150\text{ V}$ $I_C = 8\text{ A}$ $I_{B1} = -I_{B2} = 1.6\text{ A}$			1 3 0.8	μs μs μs
t_s t_f	Inductive load Storage time Fall time	$V_{CC} = 300\text{ V}$ $I_C = 8\text{ A}$ $V_{BE} = -5\text{ V}$ $I_{B1} = 1.6\text{ A}$ $L_B = 3\text{ }\mu\text{H}$		3 0.13		μs μs
t_s t_f	Inductive load Storage time Fall time	$V_{CC} = 300\text{ V}$ $I_C = 8\text{ A}$ $V_{BE} = -5\text{ V}$ $I_{B1} = 1.6\text{ A}$ $L_B = 3\text{ }\mu\text{H}$ $T_C = 125\text{ °C}$			5 0.4	μs μs

1. Pulse test: pulse duration $\leq 300\text{ }\mu\text{s}$, duty cycle $\leq 2\%$

2.1 Test circuit

Figure 2. Resistive load switching test circuit

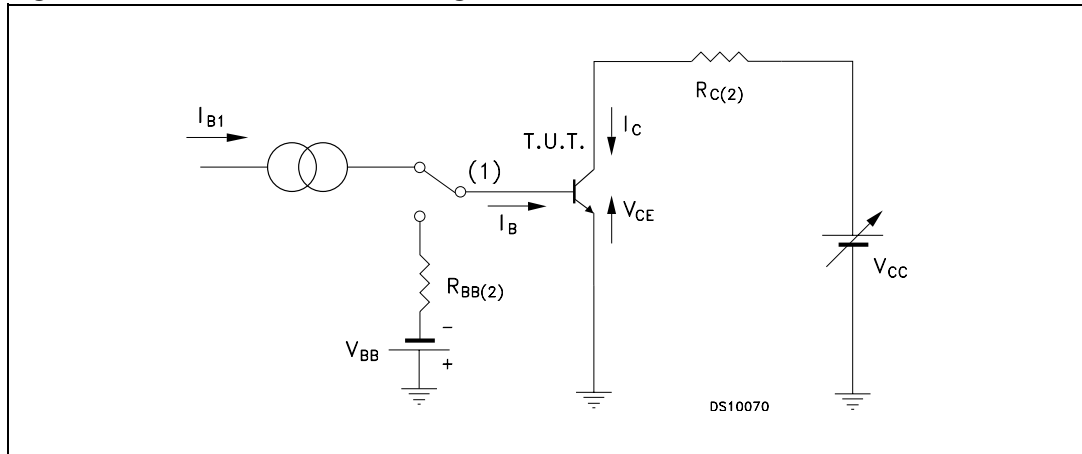

- 1. Fast electronic switch
- 2. Non-inductive resistor

Figure 3. Inductive load switching test circuit

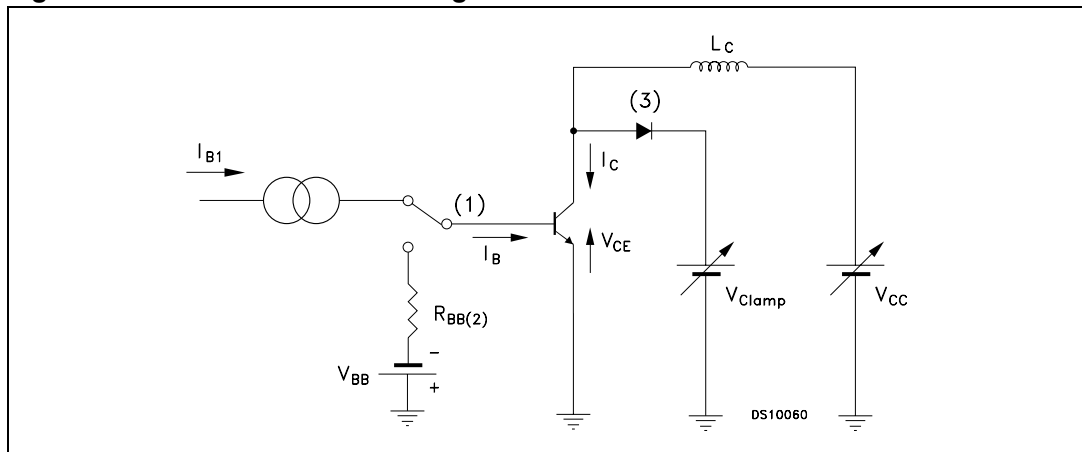

- 1. Fast electronic switch
- 2. Non-inductive resistor
- 3. Fast recovery rectifier

3 Package mechanical data

In order to meet environmental requirements, ST offers these devices in different grades of ECOPACK[®] packages, depending on their level of environmental compliance. ECOPACK[®] specifications, grade definitions and product status are available at: www.st.com. ECOPACK[®] is an ST trademark.

TO-247 mechanical data

Dim.	mm.		
	Min.	Typ.	Max.
A	4.85		5.15
A1	2.20		2.60
b	1.0		1.40
b1	2.0		2.40
b2	3.0		3.40
c	0.40		0.80
D	19.85		20.15
E	15.45		15.75
e		5.45	
L	14.20		14.80
L1	3.70		4.30
L2		18.50	
øP	3.55		3.65
øR	4.50		5.50
S		5.50	

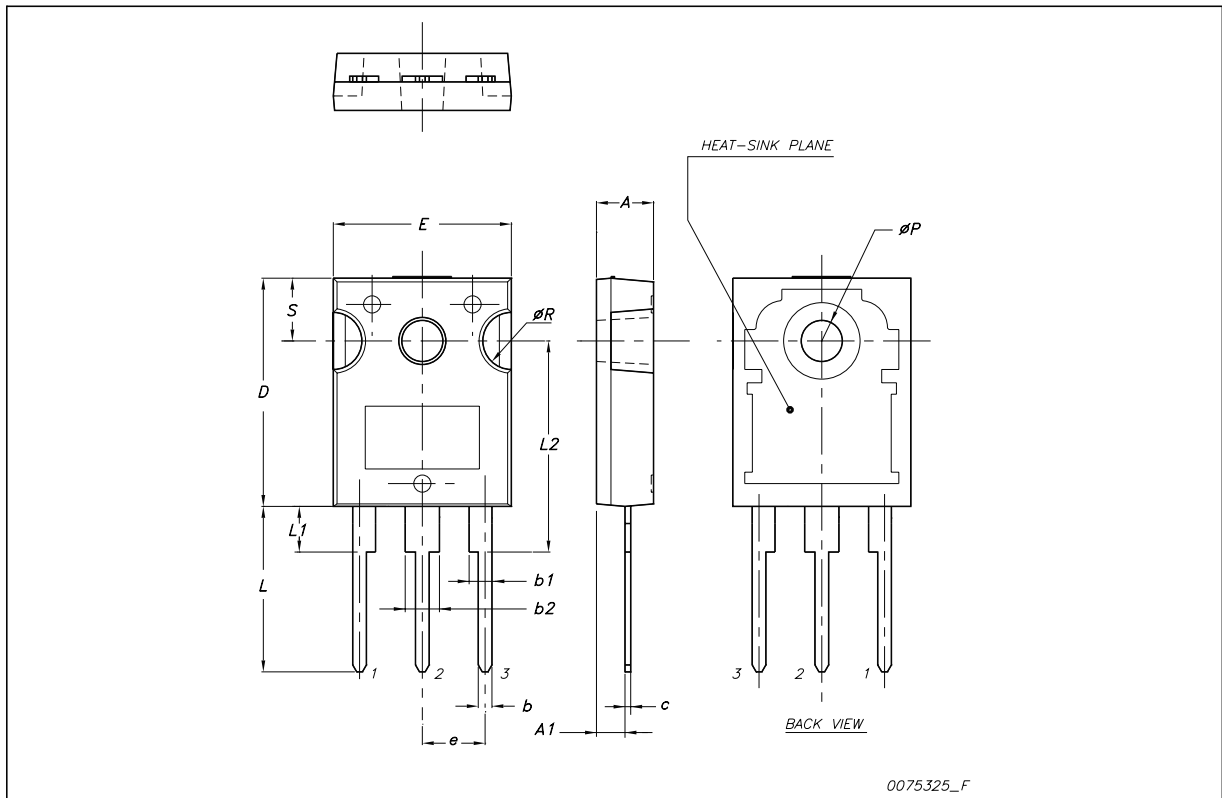

4 Revision history

Table 5. Document revision history

Date	Revision	Changes
29-Oct-2007	8	Package change from TO-218 to TO-247.
16-Nov-2009	9	Added h_{FE} specification Table 4 on page 3 .

Please Read Carefully:

Information in this document is provided solely in connection with ST products. STMicroelectronics NV and its subsidiaries ("ST") reserve the right to make changes, corrections, modifications or improvements, to this document, and the products and services described herein at any time, without notice.

All ST products are sold pursuant to ST's terms and conditions of sale.

Purchasers are solely responsible for the choice, selection and use of the ST products and services described herein, and ST assumes no liability whatsoever relating to the choice, selection or use of the ST products and services described herein.

No license, express or implied, by estoppel or otherwise, to any intellectual property rights is granted under this document. If any part of this document refers to any third party products or services it shall not be deemed a license grant by ST for the use of such third party products or services, or any intellectual property contained therein or considered as a warranty covering the use in any manner whatsoever of such third party products or services or any intellectual property contained therein.

UNLESS OTHERWISE SET FORTH IN ST'S TERMS AND CONDITIONS OF SALE ST DISCLAIMS ANY EXPRESS OR IMPLIED WARRANTY WITH RESPECT TO THE USE AND/OR SALE OF ST PRODUCTS INCLUDING WITHOUT LIMITATION IMPLIED WARRANTIES OF MERCHANTABILITY, FITNESS FOR A PARTICULAR PURPOSE (AND THEIR EQUIVALENTS UNDER THE LAWS OF ANY JURISDICTION), OR INFRINGEMENT OF ANY PATENT, COPYRIGHT OR OTHER INTELLECTUAL PROPERTY RIGHT.

UNLESS EXPRESSLY APPROVED IN WRITING BY AN AUTHORIZED ST REPRESENTATIVE, ST PRODUCTS ARE NOT RECOMMENDED, AUTHORIZED OR WARRANTED FOR USE IN MILITARY, AIR CRAFT, SPACE, LIFE SAVING, OR LIFE SUSTAINING APPLICATIONS, NOR IN PRODUCTS OR SYSTEMS WHERE FAILURE OR MALFUNCTION MAY RESULT IN PERSONAL INJURY, DEATH, OR SEVERE PROPERTY OR ENVIRONMENTAL DAMAGE. ST PRODUCTS WHICH ARE NOT SPECIFIED AS "AUTOMOTIVE GRADE" MAY ONLY BE USED IN AUTOMOTIVE APPLICATIONS AT USER'S OWN RISK.

Resale of ST products with provisions different from the statements and/or technical features set forth in this document shall immediately void any warranty granted by ST for the ST product or service described herein and shall not create or extend in any manner whatsoever, any liability of ST.

ST and the ST logo are trademarks or registered trademarks of ST in various countries.

Information in this document supersedes and replaces all information previously supplied.

The ST logo is a registered trademark of STMicroelectronics. All other names are the property of their respective owners.

© 2009 STMicroelectronics - All rights reserved



STMicroelectronics group of companies

Australia - Belgium - Brazil - Canada - China - Czech Republic - Finland - France - Germany - Hong Kong - India - Israel - Italy - Japan - Malaysia - Malta - Morocco - Philippines - Singapore - Spain - Sweden - Switzerland - United Kingdom - United States of America

www.st.com

Looking for pricing, stock, or lifecycle information?

Click below to explore more details on WIN SOURCE:

-  [View **BUV48A** on WIN SOURCE](#)
-  [STMicroelectronics Information](#)

Optimize Your Supply Chain with WIN SOURCE Solutions

-  Global Sourcing Solution
-  Obsolete Management
-  Cost Control Management
-  Shortage Management
-  Alternative Solution
-  Excess Inventory Management