



# THE DATASHEET OF RT9011-MQGQWC



## Portable Power Management 300mA Dual LDO Regulator

### General Description

The RT9011 is a dual channel, low noise, and low dropout regulator sourcing up to 300mA at each channel. The range of output voltage is from 1.2V to 3.6V by operating from 2.5V to 5.5V input.

The RT9011 offers 2% accuracy, extremely low dropout voltage (240mV @ 300mA), and extremely low ground current, only 27µA per LDO. The shutdown current is near zero current which is suitable for battery-power devices. Other features include current limiting, over temperature, output short circuit protection.

The RT9011 is short circuit thermal folded back protected. The IC lowers its OTP trip point from 165°C to 110°C when output short circuit occurs (VOUT < 0.4V) providing maximum safety to end users.

The RT9011 can operate stably with very small ceramic output capacitors, reducing required board space and component cost. The RT9011 is available in fixed output voltages in the TSOT-23-6, WDFN-8L 2x2, WDFN-10L 3x3, WDFN-8L 3x3 and WDFN-6L 1.6x1.6 packages.

### Ordering Information

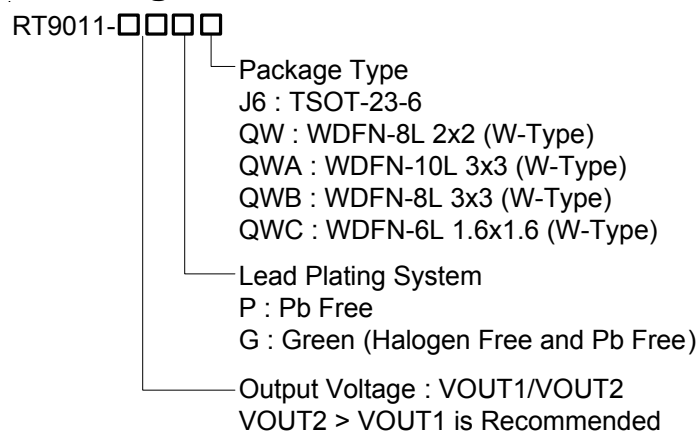

Note :

Richtek products are :

- ▶ RoHS compliant and compatible with the current requirements of IPC/JEDEC J-STD-020.
- ▶ Suitable for use in SnPb or Pb-free soldering processes.

### Features

- **Wide Operating Voltage Ranges : 2.5V to 5.5V**
- **Low-Noise for RF Application**
- **No Noise Bypass Capacitor Required**
- **Fast Response in Line/Load Transient**
- **TTL-Logic-Controlled Shutdown Input**
- **Low Temperature Coefficient**
- **Dual LDO Outputs (300mA/300mA)**
- **Ultra-low Quiescent Current 27µA/LDO**
- **High Output Accuracy 2%**
- **Short Circuit Protection**
- **Thermal Shutdown Protection**
- **Current Limit Protection**
- **Short Circuit Thermal Folded Back Protection**
- **Tiny TSOT-23-6 and 6-Lead/8-Lead/10-Lead WDFN Packages**
- **RoHS Compliant and 100% Lead (Pb)-Free**

### Applications

- CDMA/GSM Cellular Handsets
- Battery-Powered Equipment
- Laptop, Palmtops, Notebook Computers
- Hand-Held Instruments
- PCMCIA Cards
- Portable Information Appliances

### Marking Information

For marking information, contact our sales representative directly or through a Richtek distributor located in your area.

### Available Voltage Version

Code	Voltage	Code	Voltage	Code	Voltage
A	3.5	B	1.3	C	1.2
D	1.85	E	2.1	F	1.5
G	1.8	H	2	J	2.5
K	2.6	L	2.7	M	2.8
N	2.85	P	3	Q	3.1
R	3.2	S	3.3	T	2.65
V	2.9	W	1.6	X	3.15
Y	1.9				

## Pin Configurations

(TOP VIEW)

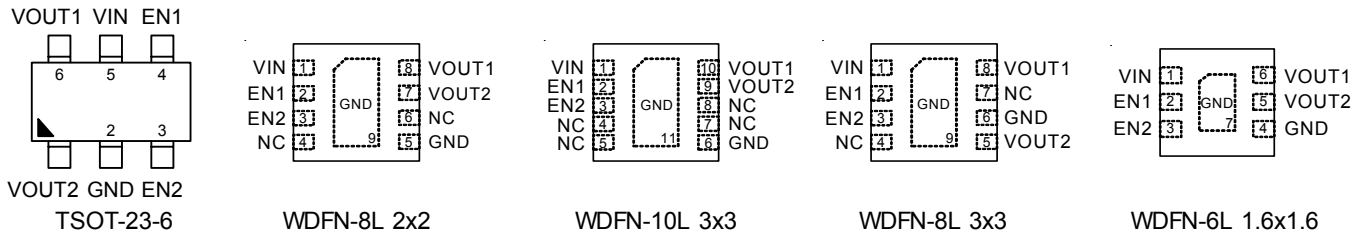

## Typical Application Circuit

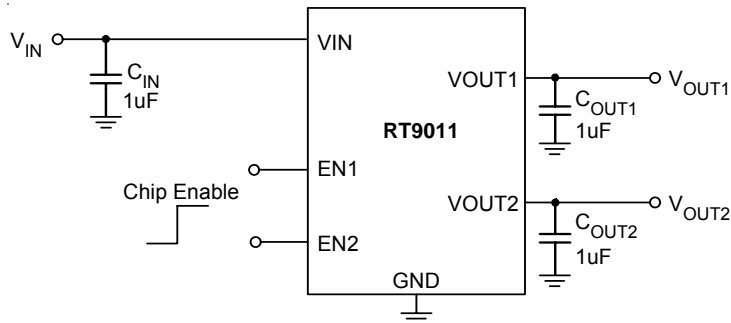

## Functional Pin Description

TSOT-23-6	Pin No.				Pin Name	Pin Function
	WDFN-8L 2x2	WDFN-10L 3x3	WDFN-8L 3x3	WDFN-6L 1.6x1.6		
5	1	1	1	1	VIN	Supply Input.
4	2	2	2	2	EN1	Chip Enable1 (Active High).
3	3	3	3	3	EN2	Chip Enable2 (Active High).
2	5, Exposed Pad (9)	6, Exposed Pad (11)	6, Exposed Pad (9)	4, Exposed Pad (7)	GND	Common Ground. The exposed pad must be soldered to a large PCB and connected to GND for maximum power dissipation.
1	7	9	5	5	VOUT2	Channel 2 Output Voltage.
6	8	10	8	6	VOUT1	Channel 1 Output Voltage.
--	4, 6	4, 5, 7, 8	4, 7	--	NC	No Internal Connection.

**Function Block Diagram**

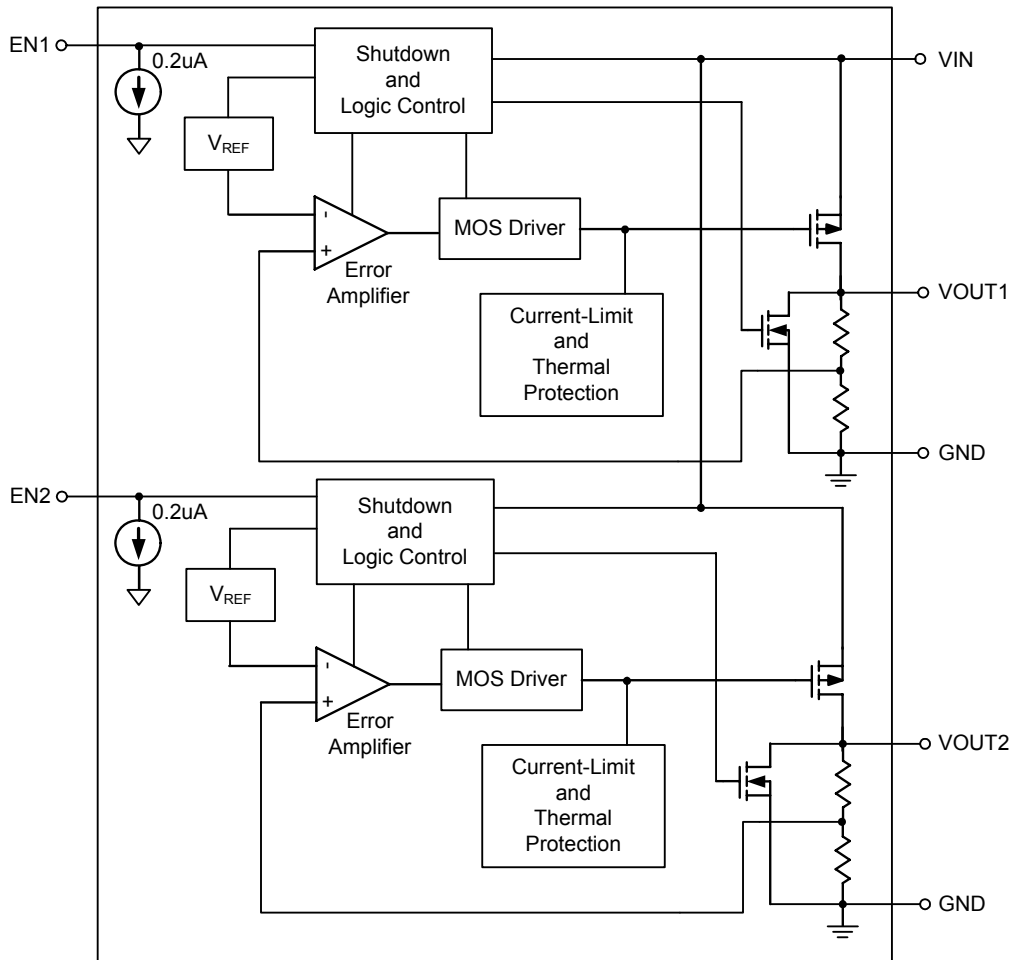

## Absolute Maximum Ratings (Note 1)

• Supply Input Voltage	-----	-0.3V to 7V
• Other I/O Pin Voltages	-----	-0.3V to 7V
• Power Dissipation, $P_D$ @ $T_A = 25^\circ\text{C}$		
TSOT-23-6	-----	0.455W
WDFN-8L 2x2	-----	0.606W
WDFN-10L 3x3	-----	0.926W
WDFN-8L 3x3	-----	0.926W
WDFN-6L 1.6x1.6	-----	0.571W
• Package Thermal Resistance (Note 2)		
TSOT-23-6, $\theta_{JA}$	-----	220°C/W
WDFN-8L 2x2, $\theta_{JA}$	-----	165°C/W
WDFN-10L 3x3, $\theta_{JA}$	-----	108°C/W
WDFN-8L 3x3, $\theta_{JA}$	-----	108°C/W
WDFN-6L 1.6x1.6, $\theta_{JA}$	-----	175°C/W
• Junction Temperature	-----	150°C
• Lead Temperature (Soldering, 10 sec.)	-----	260°C
• Storage Temperature Range	-----	-65°C to 150°C
• ESD Susceptibility (Note 3)		
HBM (Human Body Mode)	-----	2kV
MM (Machine Mode)	-----	200V

## Recommended Operating Conditions (Note 4)

• Supply Input Voltage	-----	2.5V to 5.5V
• Enable Input Voltage	-----	0V to 5.5V
• Junction Temperature Range	-----	-40°C to 125°C
• Ambient Temperature Range	-----	-40°C to 85°C

## Electrical Characteristics

( $V_{IN} = V_{OUT} + 1V$ ,  $V_{EN} = V_{IN}$ ,  $C_{IN} = C_{OUT} = 1\mu\text{F}$ ,  $T_A = -40^\circ\text{C}$  to  $85^\circ\text{C}$ , unless otherwise specified.)

Parameter	Symbol	Test Conditions	Min	Typ	Max	Unit
Input Voltage		$V_{IN} = 2.5V$ to $5.5V$	2.5	--	5.5	V
Dropout Voltage (Note 5)	$V_{DROP}$	$I_{OUT} = 300\text{mA}$	--	240	330	mV
Output voltage range	$V_{OUT}$		1.2	--	3.6	V
$V_{OUT}$ Accuracy	$\Delta V$	$I_{OUT} = 1\text{mA}$ to $300\text{mA}$	-3	--	+3	%
Line Regulation	$\Delta V_{LINE}$	$V_{IN} = (V_{OUT} + 0.3V)$ to $5.5V$ or $V_{IN} > 2.5V$ , whichever is larger	--	--	0.2	%/V
Load Regulation	$\Delta V_{LOAD}$	$1\text{mA} < I_{OUT} < 300\text{mA}$	--	--	0.6	%
Current Limit		$R_{LOAD} = 1\Omega$	330	450	700	mA
Quiescent Current	$I_Q$	$V_{EN} > 1.5V$	--	58	80	$\mu\text{A}$
Shutdown Current	$I_{Q\_SD}$	$V_{EN} < 0.4V$	--	--	1	$\mu\text{A}$
EN Threshold	$V_{IH}$	$V_{IN} = 2.5V$ to $5.5V$ , Power On	1.5	--	--	V
	$V_{IL}$	$V_{IN} = 2.5V$ to $5.5V$ , Shutdown	--	--	0.4	

*To be continued*

Parameter	Symbol	Test Conditions	Min	Typ	Max	Unit
Output Voltage TC			--	100	--	ppm/°C
V <sub>OUT</sub> Discharge Resistance in Shutdown (Note 6)		V <sub>IN</sub> = 5V, EN1 = EN2 = GND	--	3	--	kΩ
EN Pull Low Current	I <sub>EN</sub>		--	0.2	--	μA
Thermal Shutdown	T <sub>SD</sub>		--	170	--	°C
Thermal Shutdown Hysteresis	ΔT <sub>SD</sub>		--	40	--	°C
PSRR V <sub>IN</sub> = V <sub>OUT</sub> + 1V, C <sub>OUT</sub> = 2.2μF I <sub>LOAD</sub> = 50mA	PSRR	f = 100Hz	--	70	--	dB
		f = 1kHz	--	70	--	
		f = 10kHz	--	70	--	
		f = 100kHz	--	54	--	
		f = 200kHz	--	45	--	
		f = 300kHz	--	38	--	
Output Voltage Noise		C <sub>OUT1</sub> = C <sub>OUT2</sub> = 10uF, 10Hz to 100kHz, I <sub>OUT1</sub> = I <sub>OUT2</sub> = 1mA	--	100	--	uVrms

**Note 1.** Stresses listed as the above "Absolute Maximum Ratings" may cause permanent damage to the device. These are for stress ratings. Functional operation of the device at these or any other conditions beyond those indicated in the operational sections of the specifications is not implied. Exposure to absolute maximum rating conditions for extended periods may remain possibility to affect device reliability.

**Note 2.** θ<sub>JA</sub> is measured in the natural convection at T<sub>A</sub> = 25°C on a low effective single layer thermal conductivity test board of JEDEC 51-3 thermal measurement standard.

**Note 3.** Devices are ESD sensitive. Handling precaution recommended.

**Note 4.** The device is not guaranteed to function outside its operating conditions.

**Note 5.** The dropout voltage is defined as V<sub>IN</sub> -V<sub>OUT</sub>, which is measured when V<sub>OUT</sub> is V<sub>OUT(NORMAL)</sub> – 100mV.

**Note 6.** It is guaranteed by design.

## Typical Operating Characteristics

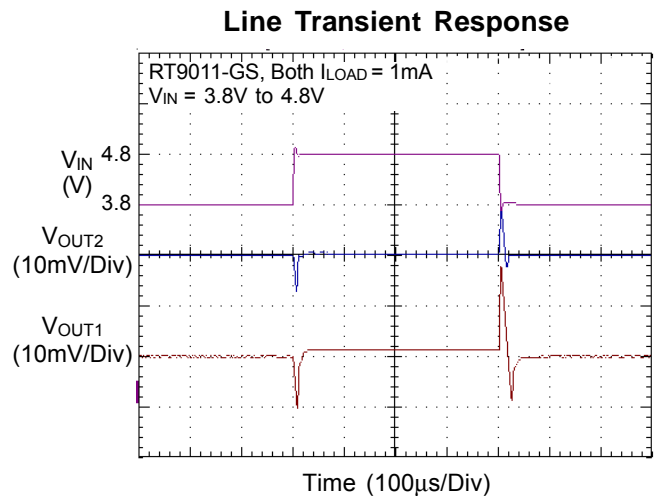
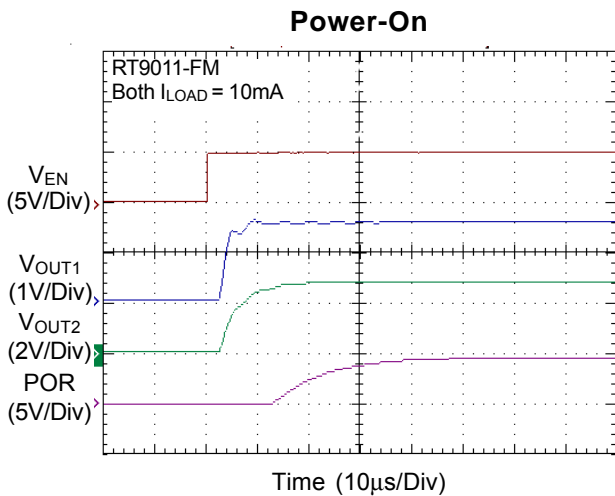
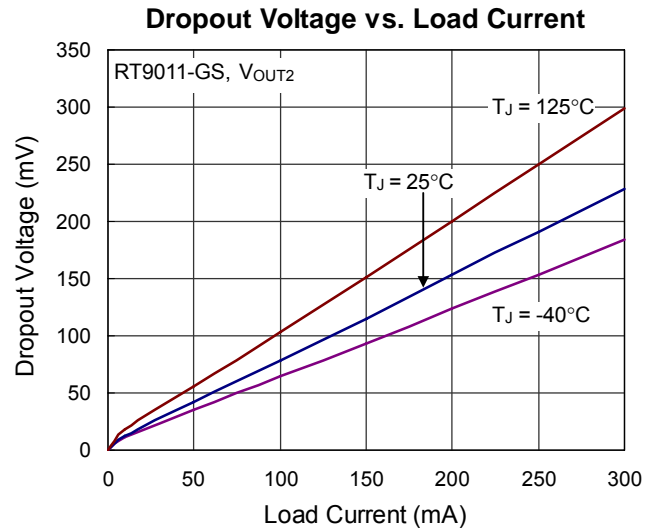
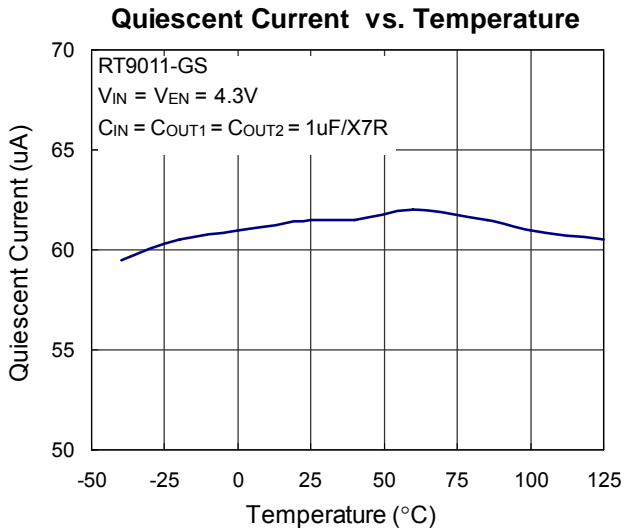
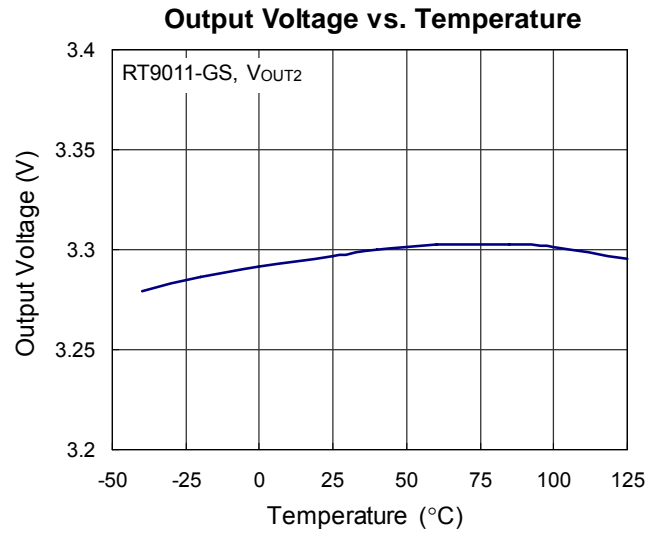
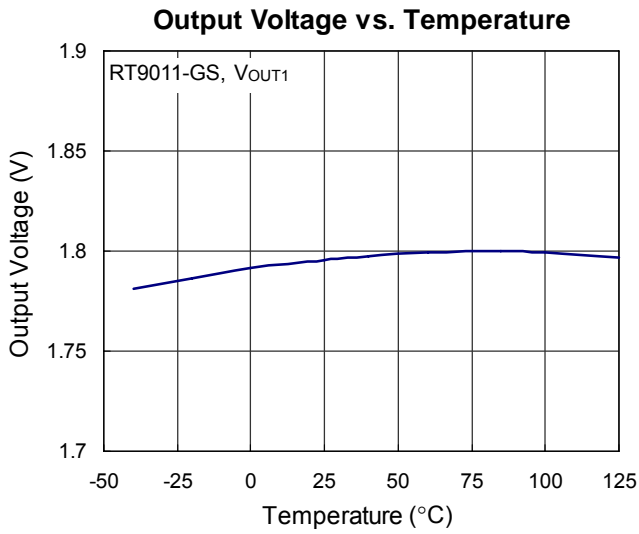

Line Transient Response

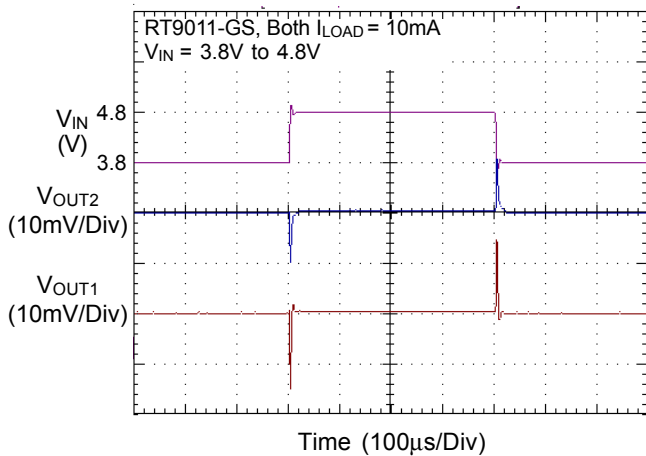

Line Transient Response

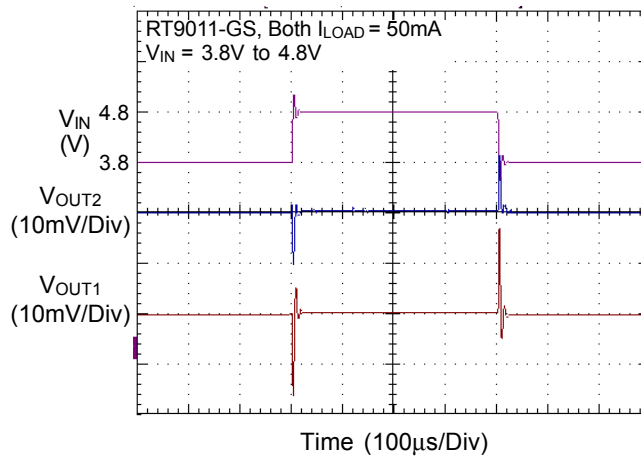

Line Transient Response

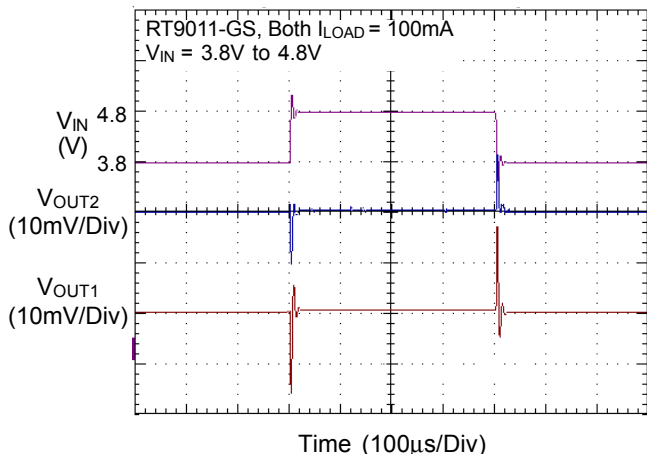

Load Transient Response

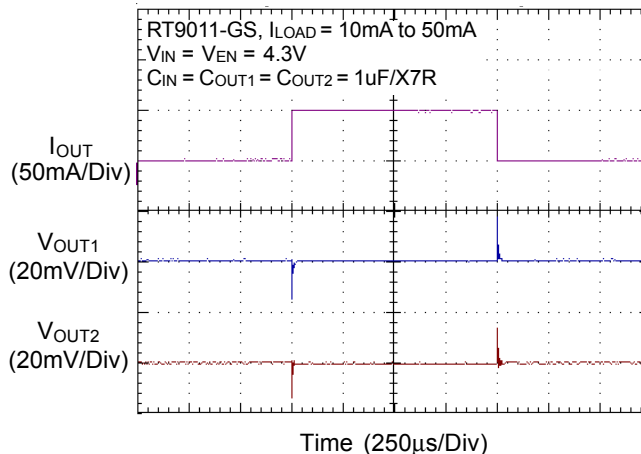

Load Transient Response

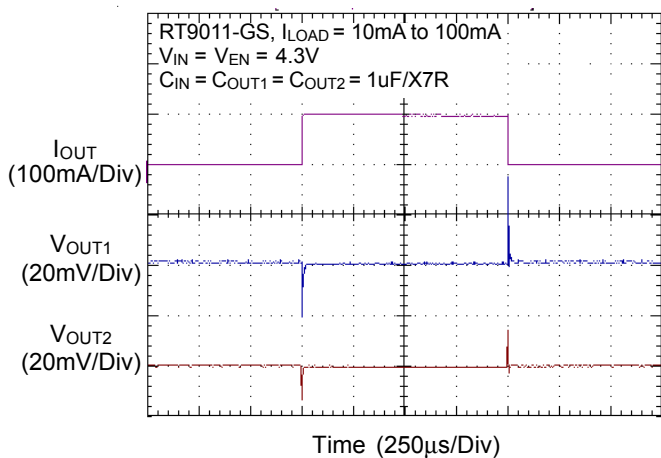

Start Up

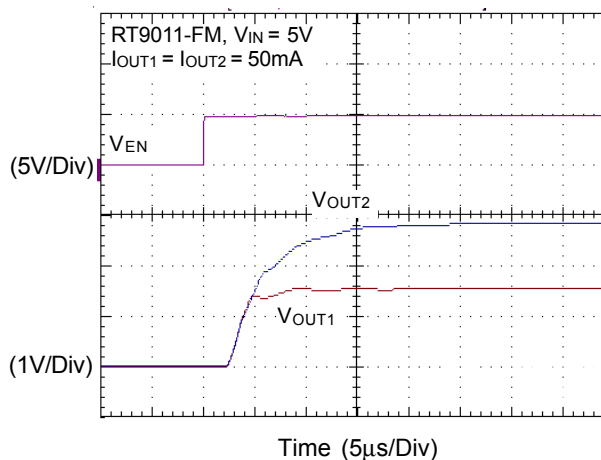

**EN Pin Shutdown Response**

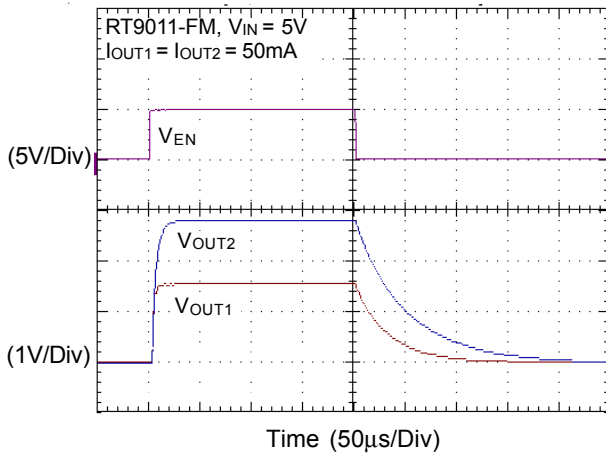

**PSRR**

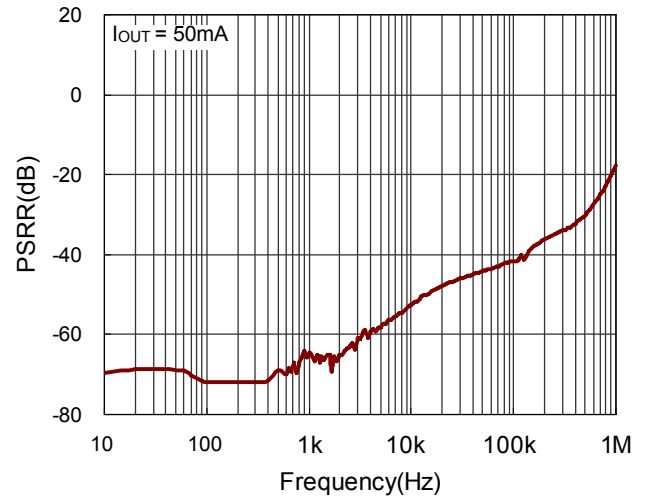

**Noise**

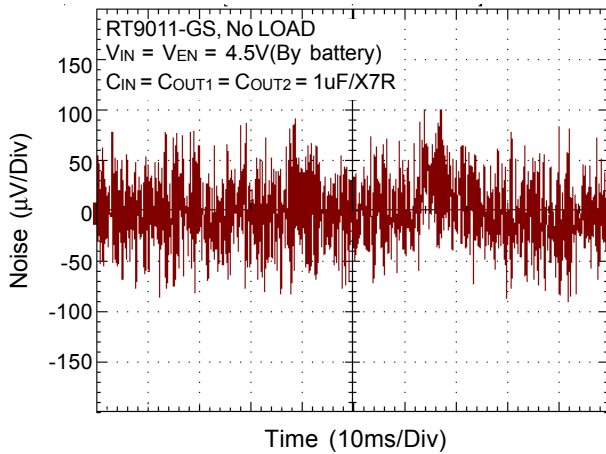

**Noise**

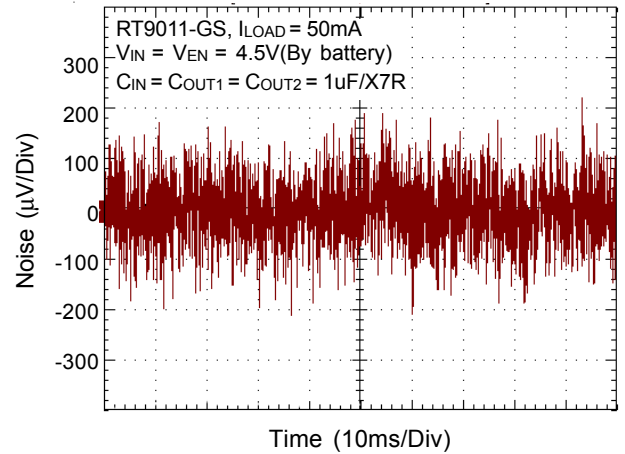

**EN1 Pin Response**

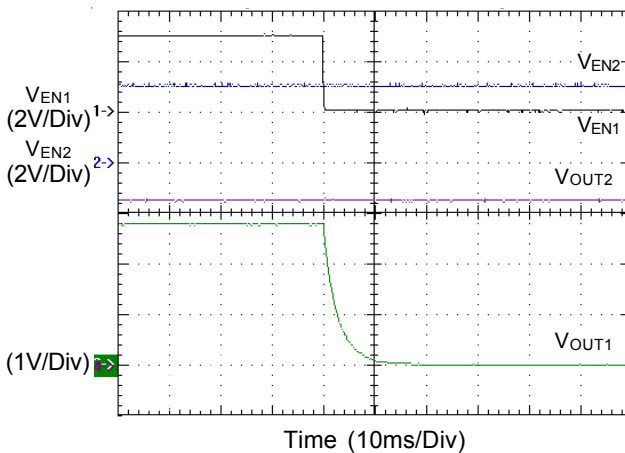

**EN2 Pin Response**

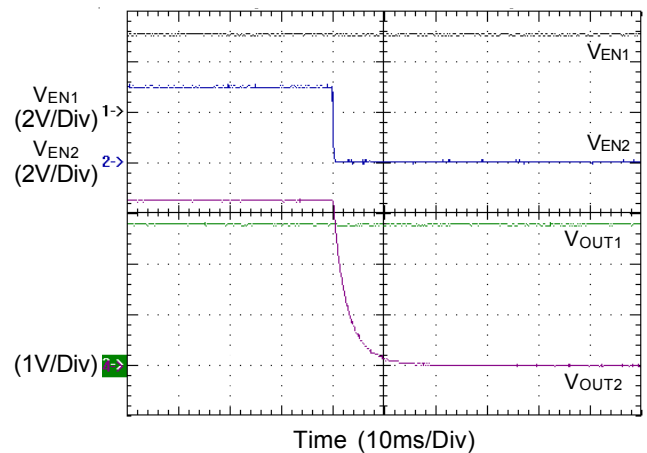

### Applications Information

Like any low-dropout regulator, the external capacitors used with the RT9011 must be carefully selected for regulator stability and performance. Using a capacitor whose value is > 1µF on the RT9011 input and the amount of capacitance can be increased without limit. The input capacitor must be located a distance of not more than 0.5 inch from the input pin of the IC and returned to a clean analog ground. Any good quality ceramic or tantalum can be used for this capacitor. The capacitor with larger value and lower ESR (equivalent series resistance) provides better PSRR and line-transient response.

The output capacitor must meet both requirements for minimum amount of capacitance and ESR in all LDOs application. The RT9011 is designed specifically to work with low ESR ceramic output capacitor in space-saving and performance consideration. Using a ceramic capacitor whose value is at least 1µF with ESR is > 20mΩ on the RT9011 output ensures stability. The RT9011 still works well with output capacitor of other types due to the wide stable ESR range. Figure 1. shows the curves of allowable ESR range as a function of load current for various output capacitor values. Output capacitor of larger capacitance can reduce noise and improve load transient response, stability, and PSRR. The output capacitor should be located not more than 0.5 inch from the VOUT pin of the RT9011 and returned to a clean analog ground.

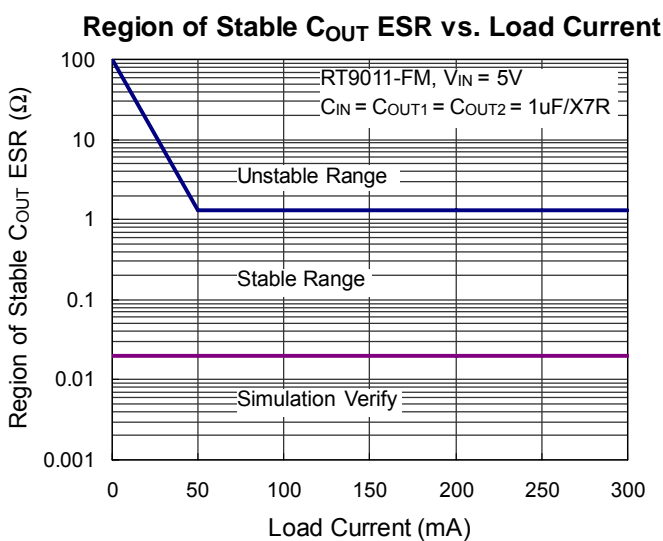

Figure 1. Stable Cout ESR Range

### Thermal Considerations

Thermal protection limits power dissipation in RT9011. When the operation junction temperature exceeds 170°C, the OTP circuit starts the thermal shutdown function and turns the pass element off. The pass element turns on again after the junction temperature cools by 40°C. RT9011 lowers its OTP trip level from 170°C to 110°C when output short circuit occurs (VOUT < 0.4V) as shown in Figure 2. It limits IC case temperature under 100°C and provides maximum safety to customer while output short circuit occurring.

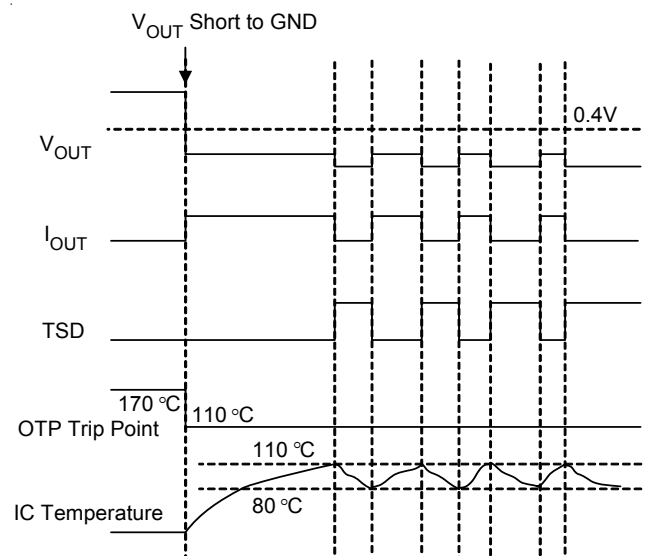

Figure 2. Short Circuit Thermal Folded Back Protection when Output Short Circuit Occurs (Patent)

For continuous operation, do not exceed absolute maximum operation junction temperature 125°C. The power dissipation definition in device is :

$$P_D = (V_{IN} - V_{OUT}) \times I_{OUT} + V_{IN} \times I_Q$$

The maximum power dissipation depends on the thermal resistance of IC package, PCB layout, the rate of surroundings airflow and temperature difference between junction to ambient. The maximum power dissipation can be calculated by following formula :

$$P_{D(MAX)} = (T_{J(MAX)} - T_A) / \theta_{JA}$$

Where  $T_{J(MAX)}$  is the maximum operation junction temperature,  $T_A$  is the ambient temperature and the  $\theta_{JA}$  is the junction to ambient thermal resistance.

For recommended operating conditions specification of RT9011, the maximum junction temperature is 125°C. The junction to ambient thermal resistance ( $\theta_{JA}$  is layout dependent) for TSOT-23-6 is 220°C/W, WDFN-8L 2x2 is 165°C/W, WDFN-10L 3x3 is 108°C/W, WDFN-8L 3x3 is 108°C/W and WDFN-8L 1.6x1.6 is 175°C/W on the standard JEDEC 51-3 single-layer thermal test board. The maximum power dissipation at  $T_A = 25^\circ\text{C}$  can be calculated by following formula :

$$P_{D(\text{MAX})} = ( 125^\circ\text{C} - 25^\circ\text{C} ) / (220^\circ\text{C/W}) = 0.455\text{W for TSOT-23-6 packages}$$

$$P_{D(\text{MAX})} = ( 125^\circ\text{C} - 25^\circ\text{C} ) / (165^\circ\text{C/W}) = 0.606\text{W for WDFN-8L 2x2 packages}$$

$$P_{D(\text{MAX})} = ( 125^\circ\text{C} - 25^\circ\text{C} ) / (108^\circ\text{C/W}) = 0.926\text{W for WDFN-10L 3x3 packages}$$

$$P_{D(\text{MAX})} = ( 125^\circ\text{C} - 25^\circ\text{C} ) / (108^\circ\text{C/W}) = 0.926\text{W for WDFN-8L 3x3 packages}$$

$$P_{D(\text{MAX})} = ( 125^\circ\text{C} - 25^\circ\text{C} ) / (175^\circ\text{C/W}) = 0.571\text{W for WDFN-6L 1.6x1.6 packages}$$

The maximum power dissipation depends on operating ambient temperature for fixed  $T_{J(\text{MAX})}$  and thermal resistance  $\theta_{JA}$ . For RT9011 packages, the Figure 3 of derating curves allows the designer to see the effect of rising ambient temperature on the maximum power allowed.

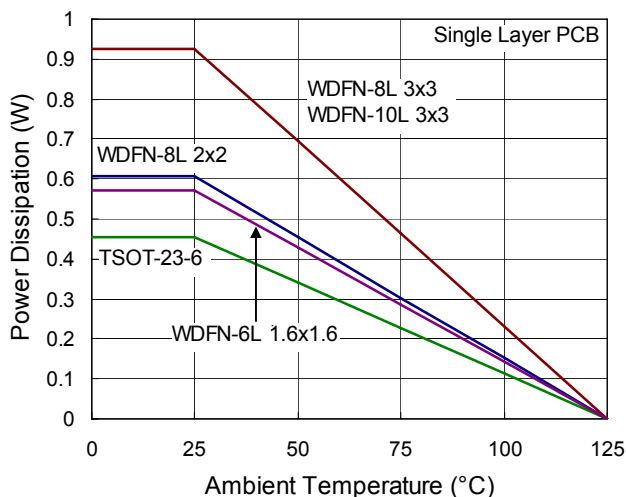
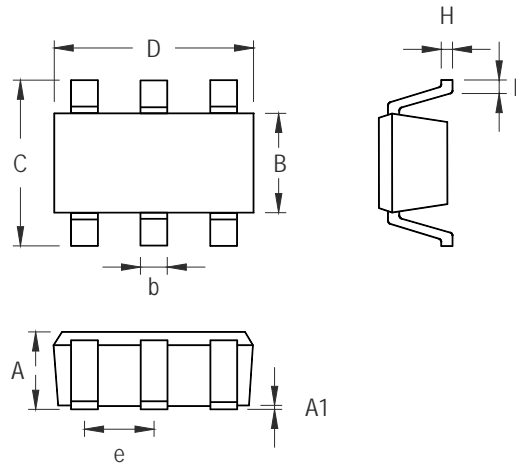

Figure 3. Derating Curves for RT9011 Packages

**Outline Dimension**



Symbol	Dimensions In Millimeters		Dimensions In Inches	
	Min	Max	Min	Max
A	0.700	1.000	0.028	0.039
A1	0.000	0.100	0.000	0.004
B	1.397	1.803	0.055	0.071
b	0.300	0.559	0.012	0.022
C	2.591	3.000	0.102	0.118
D	2.692	3.099	0.106	0.122
e	0.838	1.041	0.033	0.041
H	0.080	0.254	0.003	0.010
L	0.300	0.610	0.012	0.024

**TSOT-23-6 Surface Mount Package**

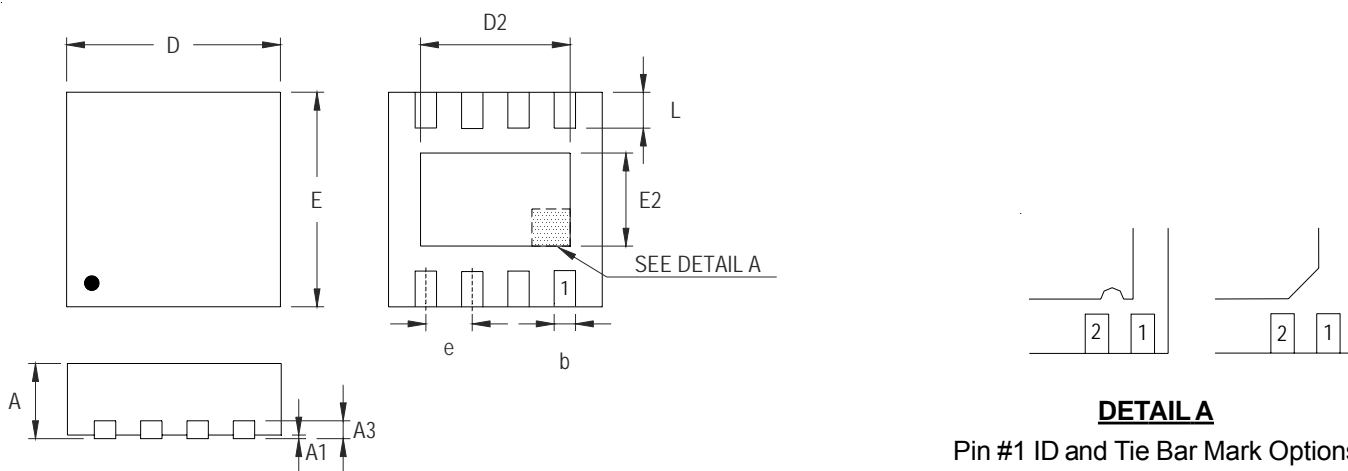

### DETAIL A

Pin #1 ID and Tie Bar Mark Options

Note : The configuration of the Pin #1 identifier is optional, but must be located within the zone indicated.

Symbol	Dimensions In Millimeters		Dimensions In Inches	
	Min	Max	Min	Max
A	0.700	0.800	0.028	0.031
A1	0.000	0.050	0.000	0.002
A3	0.175	0.250	0.007	0.010
b	0.200	0.300	0.008	0.012
D	1.950	2.050	0.077	0.081
D2	1.000	1.250	0.039	0.049
E	1.950	2.050	0.077	0.081
E2	0.400	0.650	0.016	0.026
e	0.500		0.020	
L	0.300	0.400	0.012	0.016

**W-Type 8L DFN 2x2 Package**

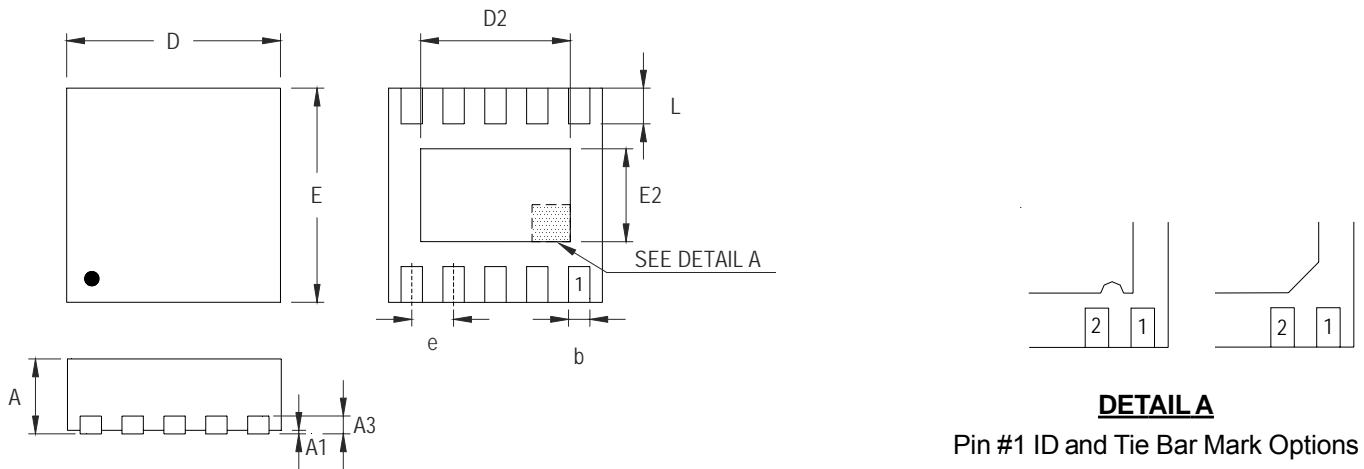

Note : The configuration of the Pin #1 identifier is optional, but must be located within the zone indicated.

Symbol	Dimensions In Millimeters		Dimensions In Inches	
	Min	Max	Min	Max
A	0.700	0.800	0.028	0.031
A1	0.000	0.050	0.000	0.002
A3	0.175	0.250	0.007	0.010
b	0.180	0.300	0.007	0.012
D	2.950	3.050	0.116	0.120
D2	2.300	2.650	0.091	0.104
E	2.950	3.050	0.116	0.120
E2	1.500	1.750	0.059	0.069
e	0.500		0.020	
L	0.350	0.450	0.014	0.018

**W-Type 10L DFN 3x3 Package**

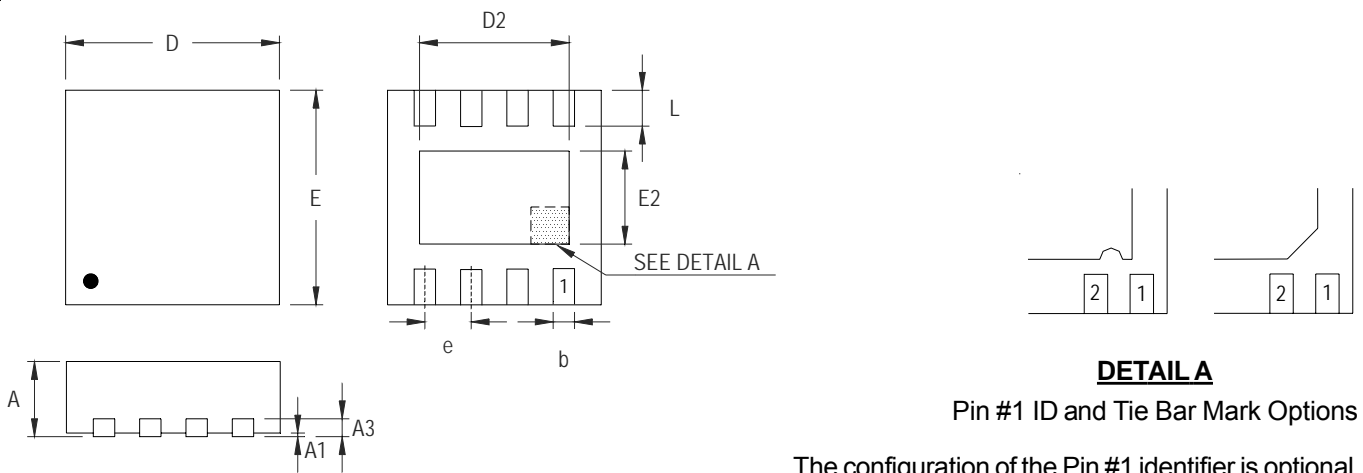

**DETAIL A**

Pin #1 ID and Tie Bar Mark Options

The configuration of the Pin #1 identifier is optional, but must be located within the zone indicated.

Symbol	Dimensions In Millimeters		Dimensions In Inches	
	Min	Max	Min	Max
A	0.700	0.800	0.028	0.031
A1	0.000	0.050	0.000	0.002
A3	0.175	0.250	0.007	0.010
b	0.200	0.300	0.008	0.012
D	2.950	3.050	0.116	0.120
D2	2.100	2.350	0.083	0.093
E	2.950	3.050	0.116	0.120
E2	1.350	1.600	0.053	0.063
e	0.650		0.026	
L	0.425	0.525	0.017	0.021

**W-Type 8L DFN 3x3 Package**

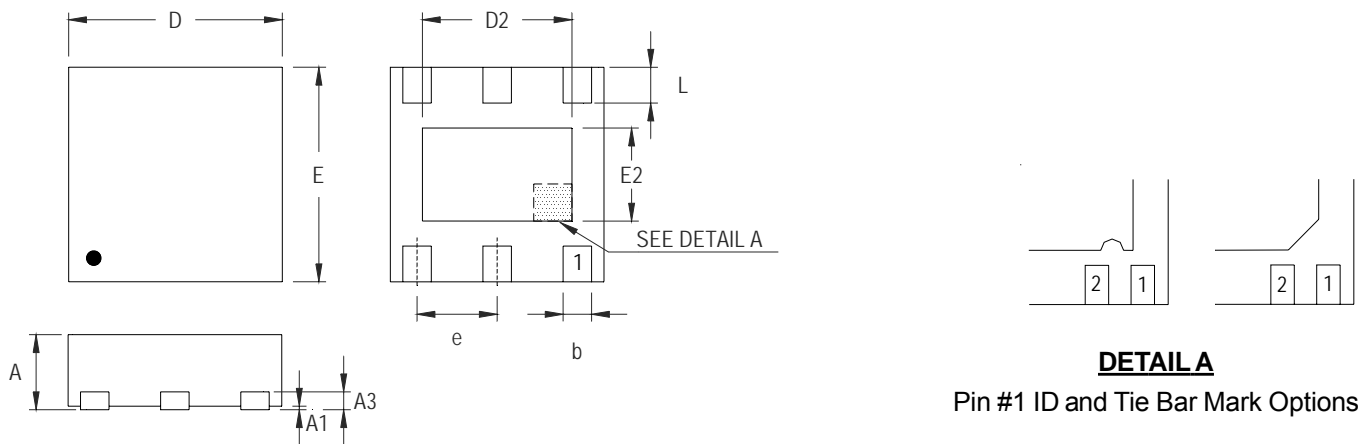

Note : The configuration of the Pin #1 identifier is optional, but must be located within the zone indicated.

Symbol	Dimensions In Millimeters		Dimensions In Inches	
	Min	Max	Min	Max
A	0.700	0.800	0.028	0.031
A1	0.000	0.050	0.000	0.002
A3	0.175	0.250	0.007	0.010
b	0.200	0.300	0.008	0.012
D	1.550	1.650	0.061	0.065
D2	0.950	1.050	0.037	0.041
E	1.550	1.650	0.061	0.065
E2	0.550	0.650	0.022	0.026
e	0.500		0.020	
L	0.190	0.290	0.007	0.011

**W-Type 6L DFN 1.6x1.6 Package**

**Richtek Technology Corporation**

Headquarter  
5F, No. 20, Taiyuen Street, Chupei City  
Hsinchu, Taiwan, R.O.C.  
Tel: (8863)5526789 Fax: (8863)5526611



**Richtek Technology Corporation**

Taipei Office (Marketing)  
5F, No. 95, Minchiuan Road, Hsintien City  
Taipei County, Taiwan, R.O.C.  
Tel: (8862)86672399 Fax: (8862)86672377  
Email: marketing@richtek.com

Information that is provided by Richtek Technology Corporation is believed to be accurate and reliable. Richtek reserves the right to make any change in circuit design, specification or other related things if necessary without notice at any time. No third party intellectual property infringement of the applications should be guaranteed by users when integrating Richtek products into any application. No legal responsibility for any said applications is assumed by Richtek.

## Looking for pricing, stock, or lifecycle information?

Click below to explore more details on WIN SOURCE:

-  [View RT9011-MQGQWC on WIN SOURCE](#)
-  [Richtek USA Inc. Information](#)

## Optimize Your Supply Chain with WIN SOURCE Solutions

-  Global Sourcing Solution
-  Obsolete Management
-  Cost Control Management
-  Shortage Management
-  Alternative Solution
-  Excess Inventory Management