



**THE DATASHEET OF
OPA569AIDWPRG4**





Rail-to-Rail I/O, 2A POWER AMPLIFIER

FEATURES

- HIGH OUTPUT CURRENT: 2A
- OUTPUT SWINGS TO: 150mV of Rails with $I_O = 2A$
- THERMAL PROTECTION
- ADJUSTABLE CURRENT LIMIT
- TWO FLAGS: Current Limit and Temperature Warning
- LOW SUPPLY VOLTAGE OPERATION: 2.7V to 5.5V
- SHUTDOWN FUNCTION WITH OUTPUT DISABLE
- SMALL POWER PACKAGE: SO-20 PowerPAD™

APPLICATIONS

- THERMOELECTRIC COOLER DRIVER
- LASER DIODE PUMP DRIVER
- VALVE, ACTUATOR DRIVER
- SYNCHRO, SERVO DRIVER
- TRANSDUCER EXCITATION
- GENERAL LINEAR POWER BOOSTER FOR OP AMPS
- PARALLELING OPTION FOR HIGHER CURRENT APPLICATIONS

DESCRIPTION

The OPA569 is a low-cost, high-current, operational amplifier designed for driving a wide variety of loads while operating on low-voltage supplies. It operates from either single or dual supplies for design flexibility and has rail-to-rail swing on the input and output. Typical output swing is within 150mV of the supply rails, with output current of 2A. Output swing closer to the rails is achievable with lighter loads.

The OPA569 is unity-gain stable, has low dc errors, is easy to use, and free from the phase inversion problems found in some power amplifiers. High performance is maintained at voltage swings near the output rails.

The OPA569 provides an accurate user-selected current limit that is set with an external resistor, or digitally adjusted via a Digital-to-Analog Converter.

The OPA569 output can be independently disabled using the Enable pin, saving power and protecting the load.

The $I_{MONITOR}$ pin provides a 1:475 bidirectional copy of the output current. This eliminates the need for a series current shunt resistor, allowing more voltage to be applied to the load. This pin can be used for simple monitoring, or feedback control to establish constant output current.

Two flags are provided: one for warning of thermal over-stress, and one for current limit condition. The Thermal Flag pin can be connected to the Enable pin to provide a thermal shutdown solution.

Packaged in the Texas Instruments PowerPAD™ package, it is small and easy to heat-sink. The OPA569 is specified for operation over the industrial temperature range, $-40^{\circ}C$ to $+85^{\circ}C$.

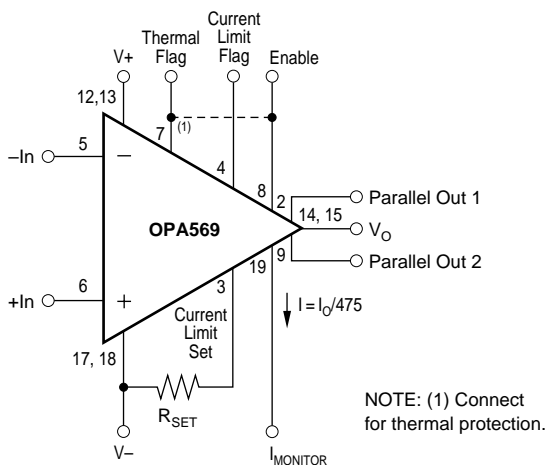

Please be aware that an important notice concerning availability, standard warranty, and use in critical applications of Texas Instruments semiconductor products and disclaimers thereto appears at the end of this data sheet.

PowerPAD is a trademark of Texas Instruments. All other trademarks are the property of their respective owners.

ABSOLUTE MAXIMUM RATINGS⁽¹⁾

Supply Voltage	+7.5V
Output Current	See SOA Curves
Signal Input Terminals (pins 2, 5, 6, and 9):	
Voltage ⁽²⁾	(V ₋) - 0.5V to (V ₊) + 0.5V
Current ⁽²⁾	±10mA
Output Short-Circuit ⁽³⁾	Continuous when thermal protection enabled
Current Monitor (pin 19) Short-Circuit	Continuous
Enable Pin (pin 8)	(V ₋) - 0.5V to (V ₋) + 7.5V
PowerPAD (pins 1, 10, 11, 20, and pad)	(V ₋) - 0.5V to (V ₋) + 0.5V
Current Limit Set (pin 3)	(V ₋) - 0.5V to (V ₊) + 0.5V
Operating Temperature	-55°C to +125°C
Storage Temperature	-65°C to +150°C
Junction Temperature	+150°C
Lead Temperature (soldering, 10s)	+300°C

NOTE: (1) Stresses above these ratings may cause permanent damage. Exposure to absolute maximum conditions for extended periods may degrade device reliability. These are stress ratings only, and functional operation of the device at these or any other conditions beyond those specified is not implied. (2) Input terminals are diode-clamped to the power-supply rails. Input signals that can swing more than 0.5V beyond the supply rails should be current limited to 10mA or less. (3) Short-circuit to ground.

PACKAGE/ORDERING INFORMATION

For the most current package and ordering information, see the Package Option Addendum located at the end of this data sheet.

PIN CONFIGURATION

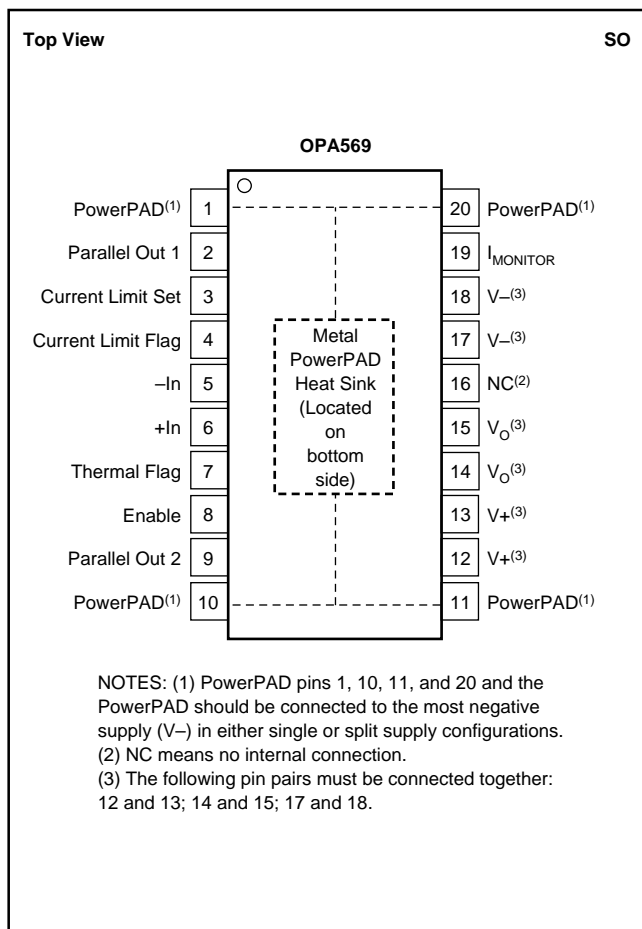

ELECTROSTATIC DISCHARGE SENSITIVITY

This integrated circuit can be damaged by ESD. Texas Instruments recommends that all integrated circuits be handled with appropriate precautions. Failure to observe proper handling and installation procedures can cause damage.

ESD damage can range from subtle performance degradation to complete device failure. Precision integrated circuits may be more susceptible to damage because very small parametric changes could cause the device not to meet its published specifications.

PIN DESCRIPTIONS

PIN #	NAME	DESCRIPTION
1, 10, 11, 20	PowerPAD	PowerPAD Connection Pins
2	Parallel Out 1	Connection for Paralleling Multiple Amplifiers
3	Current Limit Set	Current Limit Set Pin
4	Current Limit Flag	Indicates When Part is in Current Limit (Active LOW).
5	-In	Inverting Input
6	+In	Noninverting Input
7	Thermal Flag	Indicates Thermal Stress (Active LOW)
8	Enable	Enabled HIGH. Shut down LOW.
9	Parallel Out 2	Connection for Paralleling Multiple Amplifiers
12, 13	V ₊	Positive Power-Supply Voltage
14, 15	V _O	Output
16	NC	No Internal Connection
17, 18	V ₋	Negative Power-Supply Voltage
19	I _{MONITOR}	Provides 1:475 Bidirectional Copy of Output Current.

ELECTRICAL CHARACTERISTICS: $V_S = +2.7V$ to $+5.5V$

Boldface limits apply over the specified temperature range, $T_A = -40^\circ\text{C}$ to $+85^\circ\text{C}$.

At $T_{\text{CASE}} = +25^\circ\text{C}$, $R_L = 1\text{k}\Omega$, and connected to $V_S/2$, unless otherwise noted.

PARAMETER	CONDITION	OPA569			UNITS
		MIN	TYP	MAX	
OFFSET VOLTAGE Input Offset Voltage vs Temperature vs Power Supply	V_{OS} dV_{OS}/dT PSRR $I_O = 0V, V_S = +5V$ $T_A = -40^\circ\text{C}$ to $+85^\circ\text{C}$ $V_S = +2.7V$ to $+5.5V, V_{\text{CM}} = (V-) + 0.55V$		± 0.5 ± 1.3 12	± 2 60	mV $\mu\text{V}/^\circ\text{C}$ $\mu\text{V}/\text{V}$
INPUT BIAS CURRENT Input Bias Current vs Temperature Input Offset Current	I_B I_{OS}		± 1 (doubles every 10°C) ± 2	± 10 ± 10	pA pA
NOISE Input Voltage Noise Density, $f = 1\text{kHz}$ $f = 0.1\text{Hz}$ to 10Hz Current Noise Density, $f = 1\text{kHz}$	e_n i_n		12 8 0.6		$\text{nV}/\sqrt{\text{Hz}}$ $\mu\text{V}/\text{p-p}$ $\text{fA}/\sqrt{\text{Hz}}$
INPUT VOLTAGE RANGE Common-Mode Voltage Range Common-Mode Rejection Ratio	V_{CM} CMRR Linear Operation $V_S = +5V, -0.1\text{V} < V_{\text{CM}} < 3.2V$ $V_S = +5V, -0.1\text{V} < V_{\text{CM}} < 5.1V$	$(V-) - 0.1$ 80 60	100 80	$(V+) + 0.1$	V dB dB
INPUT IMPEDANCE Differential Common-Mode			$10^{13} \parallel 4.5$ $10^{13} \parallel 9$		$\Omega \parallel \text{pF}$ $\Omega \parallel \text{pF}$
OPEN-LOOP GAIN Open-Loop Voltage Gain	A_{OL} $0.2\text{V} < V_O < 4.8V, R_L = 1\text{k}\Omega, V_S = +5V$ $0.3\text{V} < V_O < 4.7V, R_L = 1.15\Omega, V_S = +5V$	100	126 90		dB dB
FREQUENCY RESPONSE Gain Bandwidth Product Slew Rate Full-Power Bandwidth ⁽¹⁾ Settling Time: $\pm 0.1\%$ Total Harmonic Distortion + Noise ⁽²⁾	GBW SR THD+N $G = +1, V_O = 4.0V$ Step $G = -1, V_O = 4.0V$ Step		1.2 1.2 See Typical Characteristics 5 See Typical Characteristics		MHz V/ μs μs
OUTPUT Voltage Output Swing from Rail Maximum Continuous Current Output: dc ⁽⁴⁾ Capacitive Load Drive ⁽⁵⁾ Output Disabled Output Impedance	V_O C_{LOAD} $R_L = 1\text{k}\Omega, A_{\text{OL}} > 100\text{dB}$ $I_O = \pm 2A, V_S = +5V, A_{\text{OL}} > 80\text{dB}$ ⁽³⁾	$(V-) + 0.2$ $(V-) + 0.3$	$(V_S) \pm 0.02$ $(V_S) \pm 0.15$ See Typical Characteristics 12M \parallel 570	$(V+) - 0.2$ $(V+) - 0.3$ 2.4	V V A $\Omega \parallel \text{pF}$
CURRENT LIMIT Output Current Limit ⁽⁶⁾ Current Limit Equation R_{SET} Equation Current Limit Tolerance ⁽⁷⁾ , Positive Negative Voltage on Current Limit Set Pin Tolerance ⁽⁸⁾	Externally Adjustable $I_{\text{LIMIT}} = 1A$ $I_{\text{LIMIT}} = 1A$	$(V-) + 1.05$	± 0.2 to ± 2.2 $I_{\text{LIMIT}} = I_{\text{SET}} \cdot 9800$ $R_{\text{SET}} = 9800 (1.18V/I_{\text{LIMIT}})$ ± 3 ± 3 $(V-) + 1.18$	± 10 ± 15 $(V-) + 1.3$	A A Ω % % V
OUTPUT CURRENT MONITOR (Pin 19) Output Current Monitor Output Current Monitor Tolerance ⁽⁹⁾ , Positive Negative Compliance Voltage Range	I_M $I_O = +1A, R_{\text{MONITOR}} = 400\Omega$ $I_O = -1A, R_{\text{MONITOR}} = 400\Omega$ Linear Operation		$I_M = I_O/475$ ± 3 ± 3 See Discussion on Current Monitor Section	± 10 ± 15	A % %

NOTES: (1) See typical characteristic "Maximum Output Voltage vs Frequency." (2) See the typical characteristic "Total Harmonic Distortion + Noise vs Frequency." (3) Swing to the rail is measured in final test. Under those conditions, the A_{OL} is derived from characterization. (4) See Safe Operating Area (SOA) plots. (5) See typical characteristic, "Overshoot vs Load Capacitance." (6) External current limit setting resistor is required. See Figure 1. (7) I_{LIMIT} is the value of the desired current limit and is equal to $9800 (I_{\text{SET}})$, where I_{SET} is the current through the Current Limit Set pin (pin 3). Errors from this parameter can be calibrated out—see Applications Information section. (8) V_{SET} is a voltage reference that equals the difference between the voltage of the Current Limit Set pin and V_- , and is referenced to the negative rail. Errors from this parameter can be calibrated out—see Applications Information section. (9) % Tolerance = $[(I_{\text{OUT}}/475) - I_{\text{MONITOR}}] \cdot 100/I_{\text{MONITOR}}$.

ELECTRICAL CHARACTERISTICS: $V_S = +2.7V$ to $+5.5V$ (Cont.)

Boldface limits apply over the specified temperature range, $T_A = -40^\circ C$ to $+85^\circ C$.

At $T_{CASE} = +25^\circ C$, $R_L = 1k\Omega$, and connected to $V_S/2$, unless otherwise noted.

PARAMETER	CONDITION	OPA569			UNITS
		MIN	TYP	MAX	
ENABLE/SHUTDOWN INPUT (Pin 8) Enable Pin Bias Current HIGH (Output enabled) LOW (Output disabled) Output Disable Time Output Enable Time	$V_{SD} = 0V$ Pin Open or Forced HIGH Pin Forced LOW $R_L = 1\Omega$ $R_L = 1\Omega$	$(V-) + 2.5$	0.2 0.5 15	 $(V-) + 0.8$	μA V V μs μs
THERMAL FLAG PIN (Pin 7) Junction Temperature: Alarm (Thermal Flag pin LOW) Return to Normal Operation (Thermal Flag pin HIGH) Thermal Flag Pin Voltage	Thermal Overstress Normal Operation Normal Operation $I_{pin 7} = +25\mu A$ During Thermal Overstress, $I_{pin 7} = -25\mu A$	 $(V+) - 0.8V$	 +147 +130 V+ V-	 $(V-) + 0.8$	 $^\circ C$ $^\circ C$ V V
CURRENT LIMIT FLAG PIN (Pin 4) Current Limit Flag Pin Voltage	Normal Operation, $I_{pin 4} = +25\mu A$ During Current Limit, $I_{pin 4} = -25\mu A$	$(V+) - 0.8V$	V+ V-	 $(V-) + 0.8$	V V
POWER SUPPLY Specified Voltage Range Operating Voltage Range Quiescent Current ⁽¹⁰⁾ Quiescent Current in Shutdown Mode	V_S $I_O = 0, I_{LIMIT} = 200mA, V_S = 5V$ $I_O = 0, I_{LIMIT} = 2A, V_S = 5V$ $I_O = 0, V_{SD} = 0.8V, V_S = 5V$	+2.7 +2.7	 +3.4 +9 +0.01	+5.5 +5.5 +6 +11	V V mA mA mA
TEMPERATURE RANGE Specified Range Operating Range Storage Range Thermal Resistance, Junction-to-Case Thermal Resistance, Junction-to-Ambient	Junction Temperature Junction Temperature 2oz Trace and 9in ² Copper Pad with Solder	-40 -55 -65	 0.37 21.5	+85 +125 +150	$^\circ C$ $^\circ C$ $^\circ C$ $^\circ C/W$ $^\circ C/W$

NOTE: (10) Quiescent current is a function of the current limit setting. See application section, "Adjustable Current Limit and Current Limit Flag Pin."

TYPICAL CHARACTERISTICS

At $T_A = +25^\circ\text{C}$, $V_S = +5\text{V}$, unless otherwise noted.

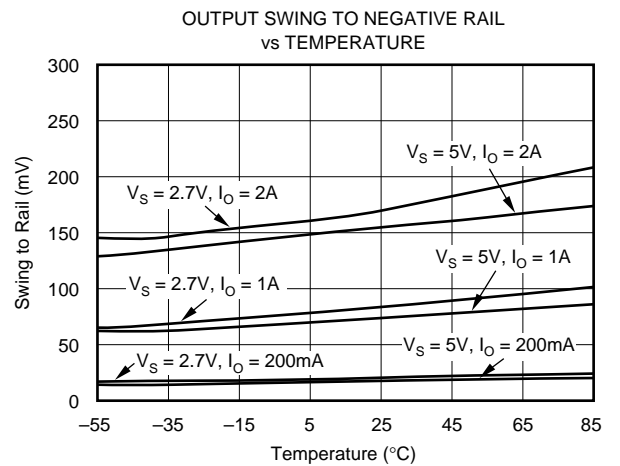
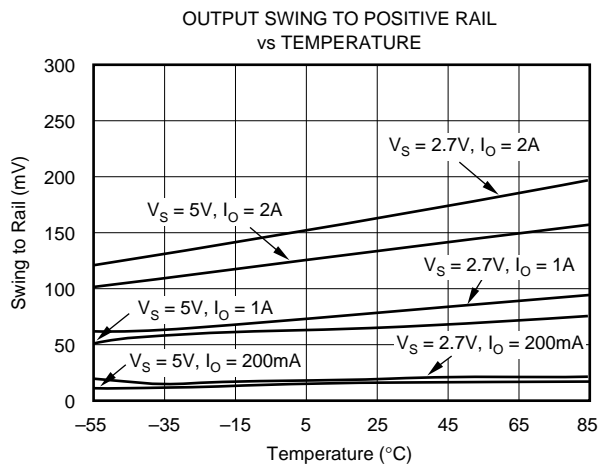
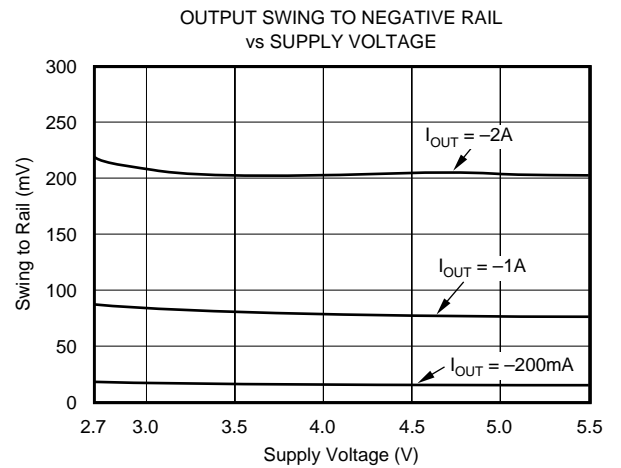
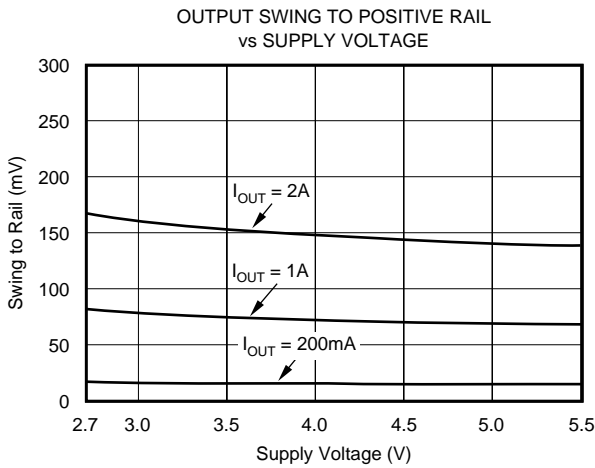
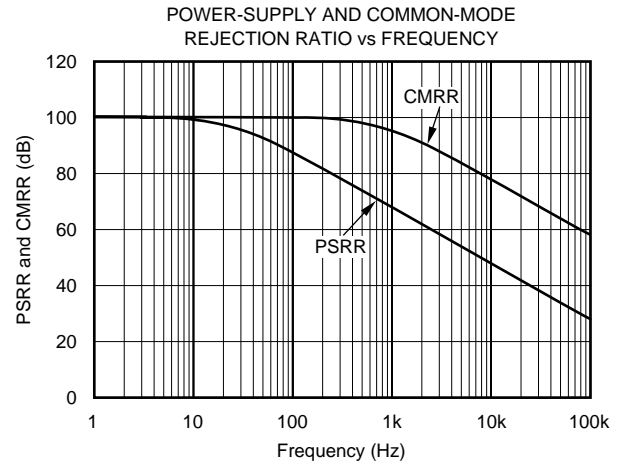
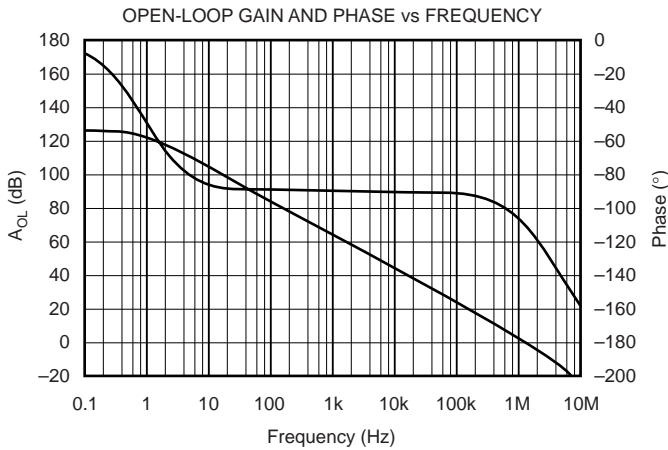

TYPICAL CHARACTERISTICS (Cont.)

At $T_A = +25^\circ\text{C}$, $V_S = +5\text{V}$, unless otherwise noted.

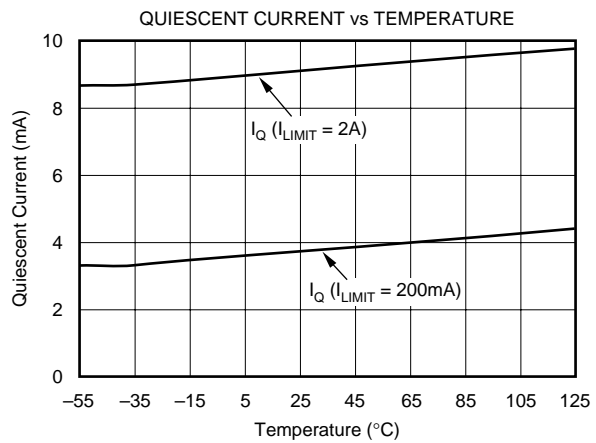
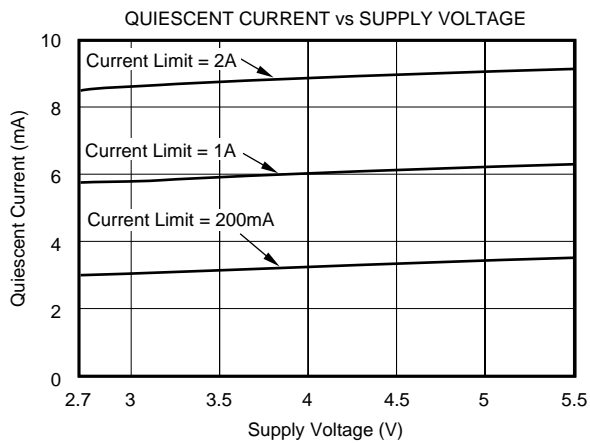
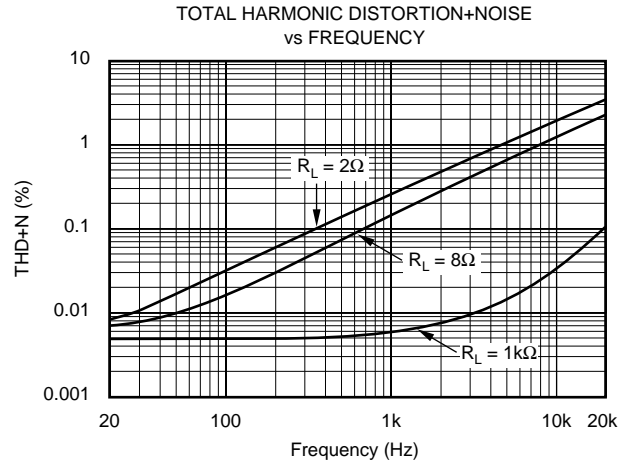
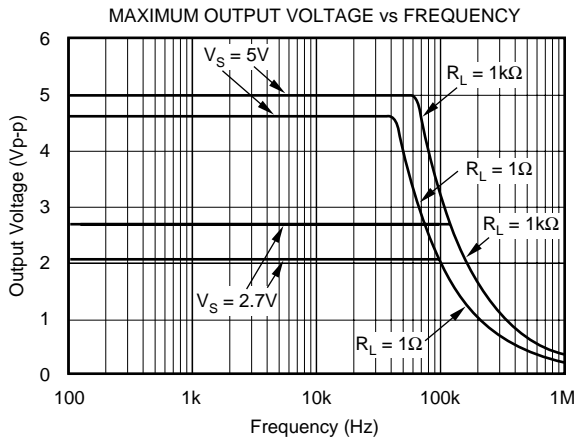
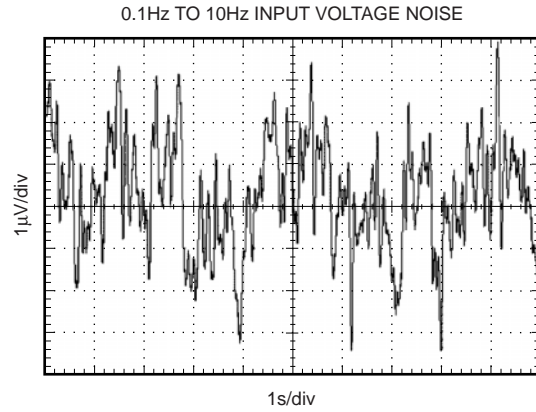
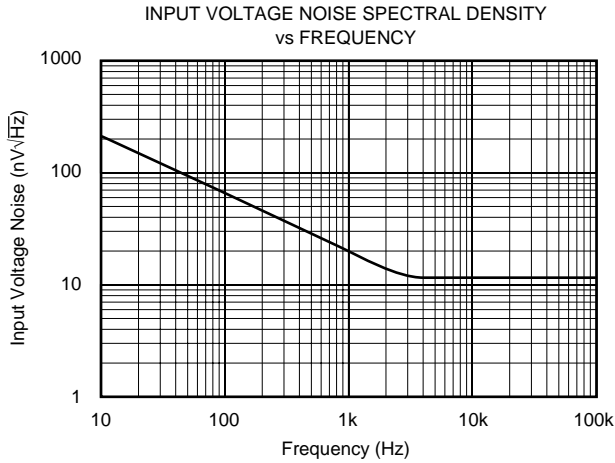

TYPICAL CHARACTERISTICS (Cont.)

At $T_A = +25^\circ\text{C}$, $V_S = +5\text{V}$, unless otherwise noted.

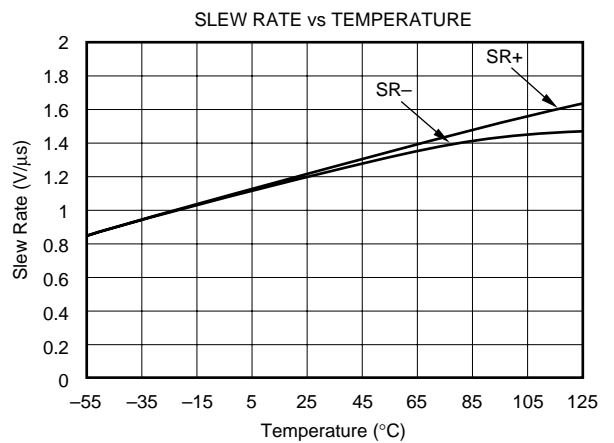
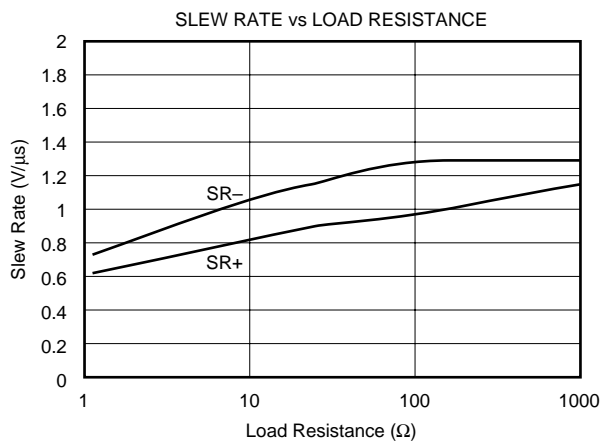
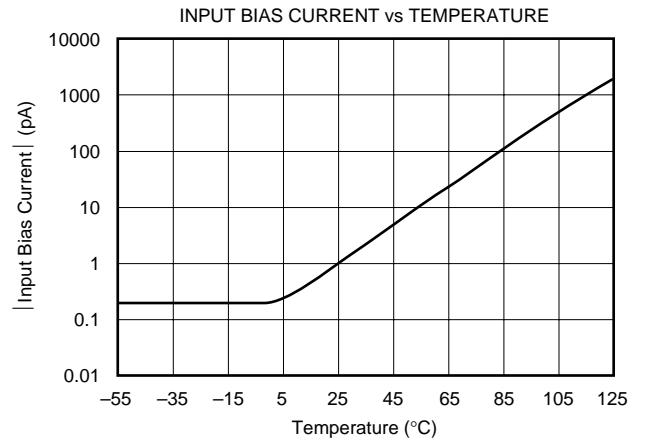
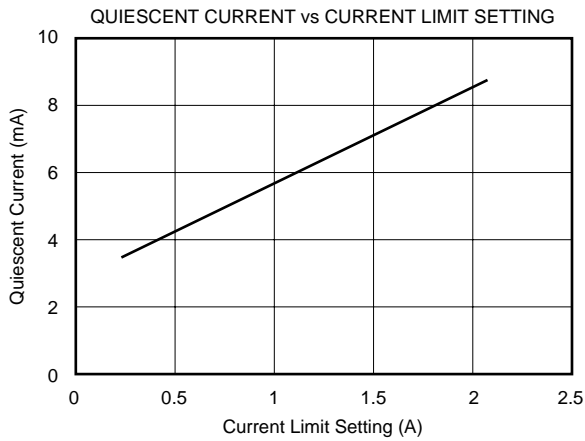
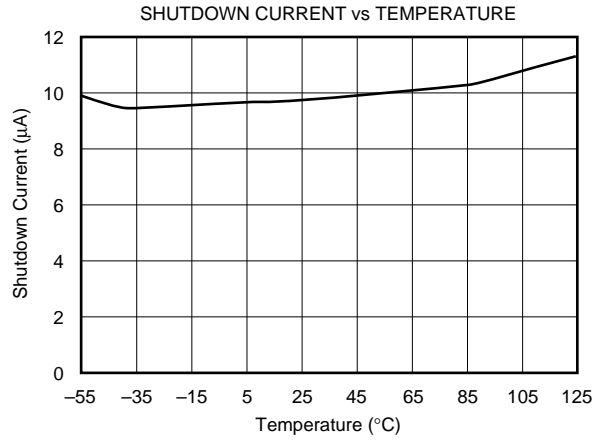
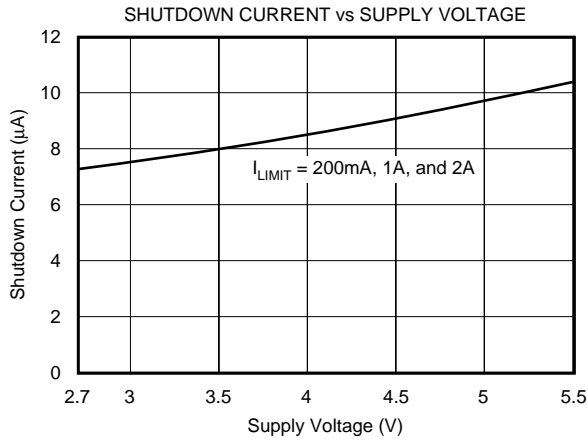

TYPICAL CHARACTERISTICS (Cont.)

At $T_A = +25^\circ\text{C}$, $V_S = +5\text{V}$, unless otherwise noted.

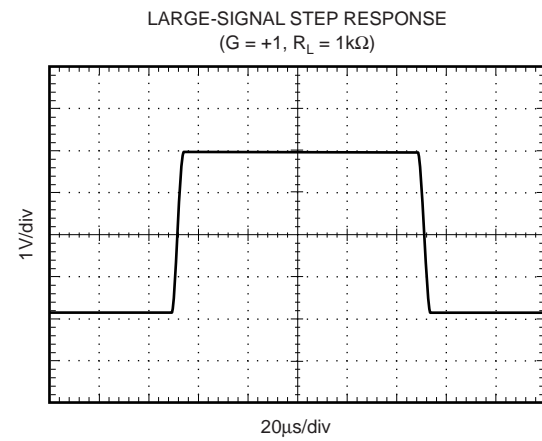
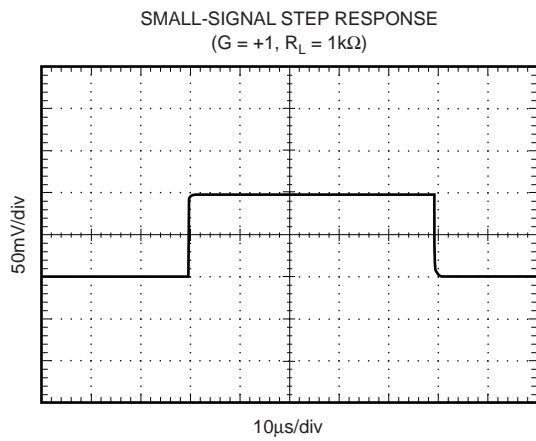
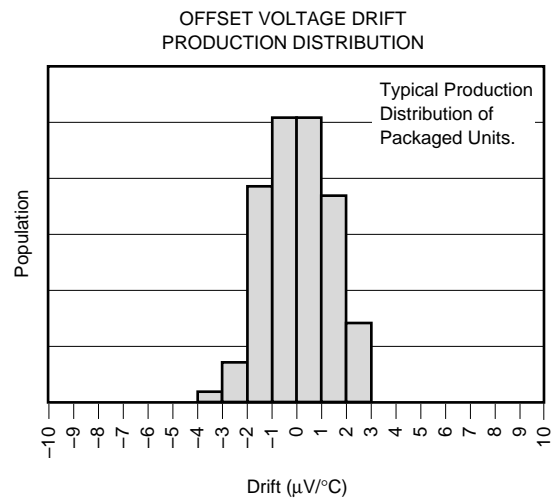
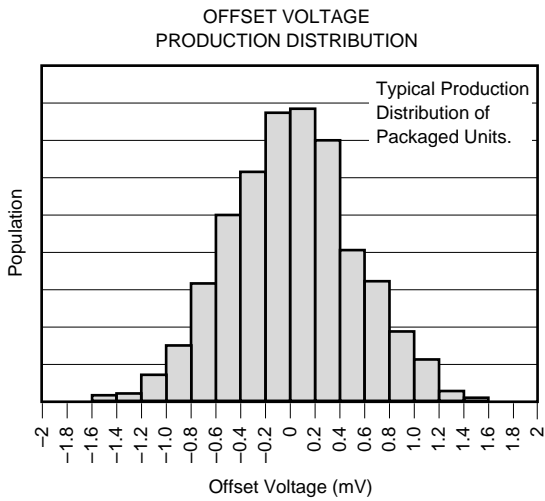
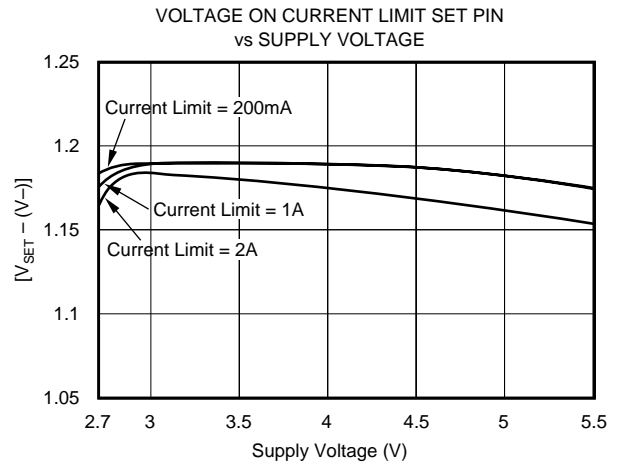
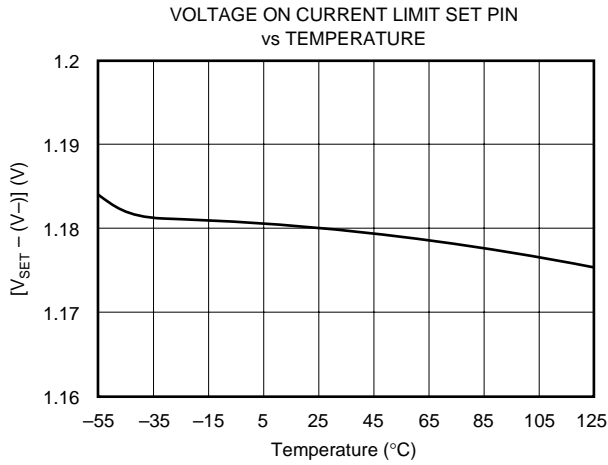

TYPICAL CHARACTERISTICS (Cont.)

At $T_A = +25^\circ\text{C}$, $V_S = +5\text{V}$, unless otherwise noted.

SMALL-SIGNAL STEP RESPONSE
($G = +1$, $R_L = 10\Omega$)

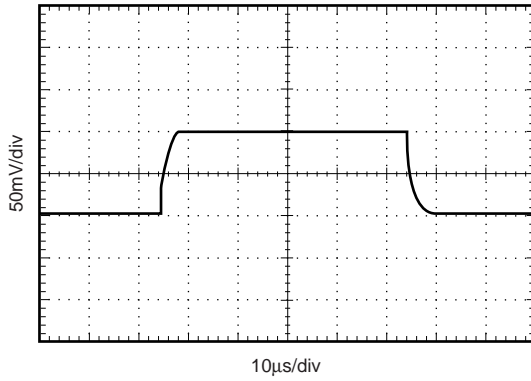

LARGE-SIGNAL STEP RESPONSE
($G = +1$, $R_L = 10\Omega$)

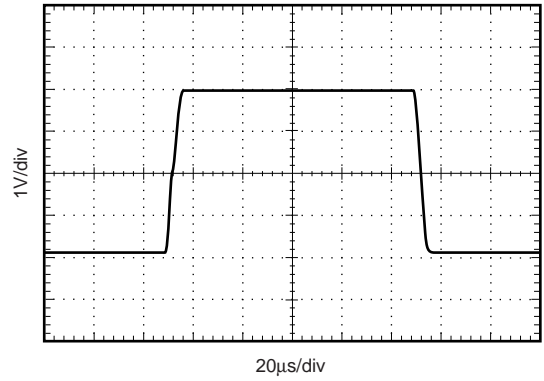

SMALL-SIGNAL STEP RESPONSE
($G = +1$, $R_L = 1\Omega$)

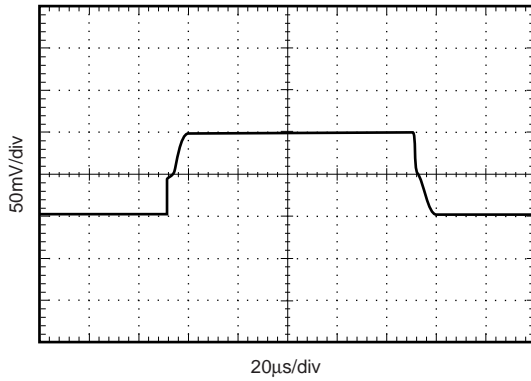

LARGE-SIGNAL STEP RESPONSE
($G = +1$, $R_L = 1\Omega$)

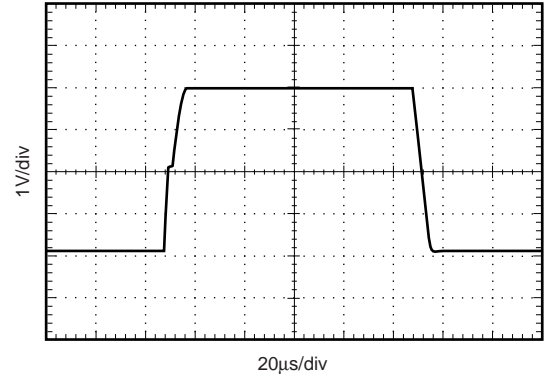

ENABLE
(10Ω Load)

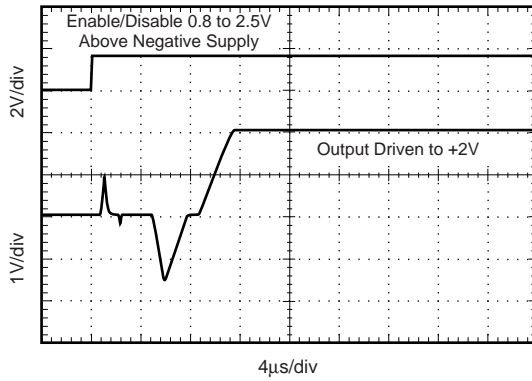

ENABLE
(1Ω Load)

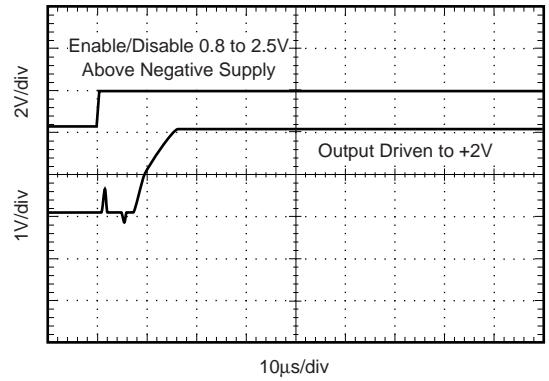

TYPICAL CHARACTERISTICS (Cont.)

At $T_A = +25^\circ\text{C}$, $V_S = +5\text{V}$, unless otherwise noted.

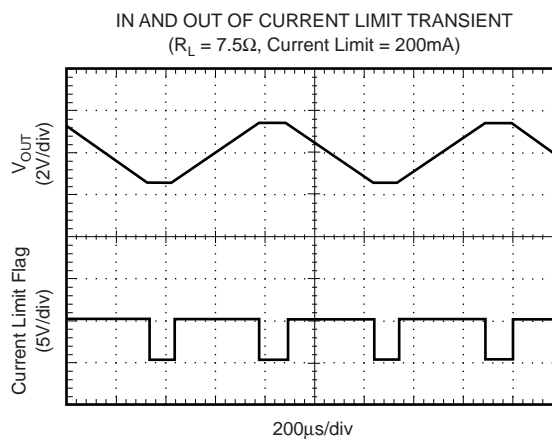
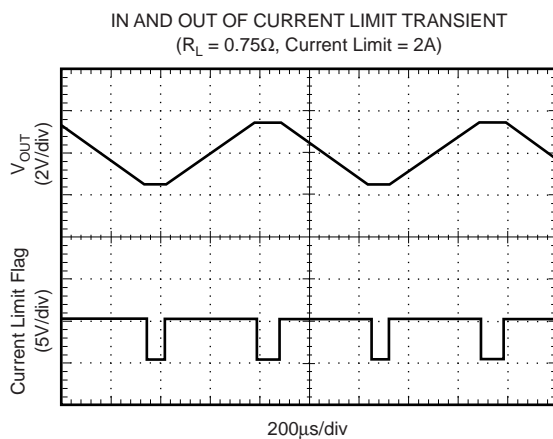
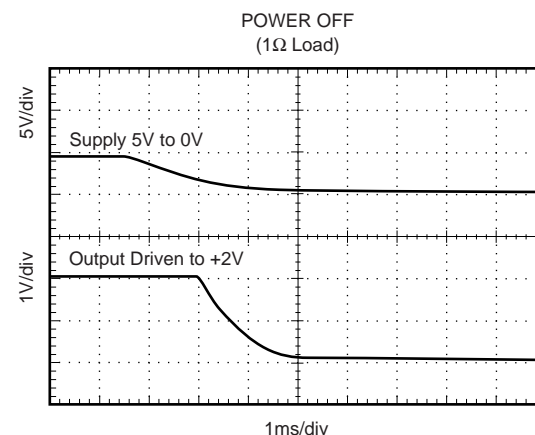
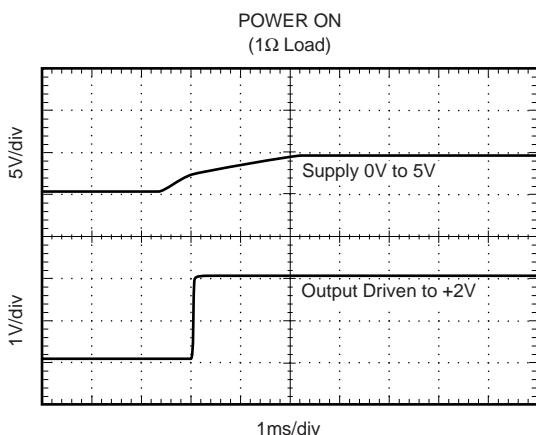
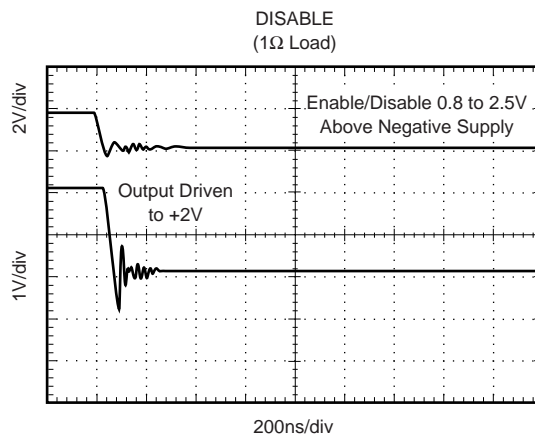
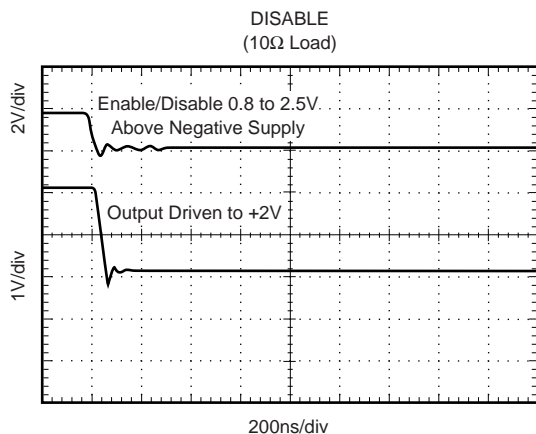

TYPICAL CHARACTERISTICS (Cont.)

At $T_A = +25^\circ\text{C}$, $V_S = +5\text{V}$, unless otherwise noted.

OVERLOAD RECOVERY
($G = +1$)

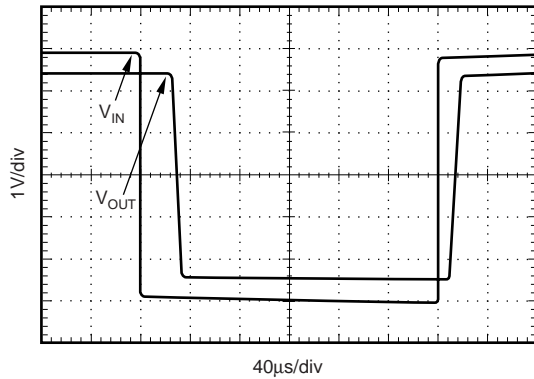

NO PHASE INVERSION WITH INPUTS
LARGER THAN SUPPLY VOLTAGE
($G = +1$, $R_L = 10\Omega$)

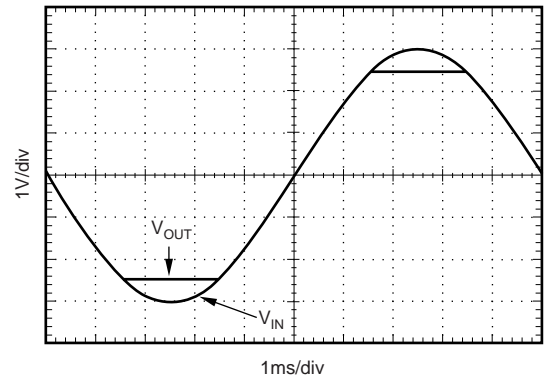

CURRENT MONITOR AND CURRENT LIMIT ERROR
vs SUPPLY VOLTAGE

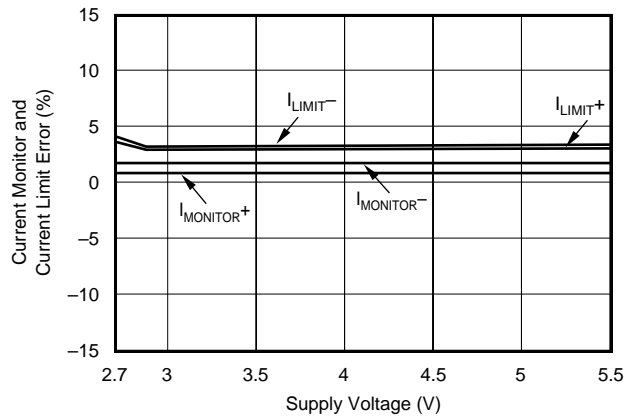

CURRENT MONITOR AND CURRENT
LIMIT ERROR vs TEMPERATURE

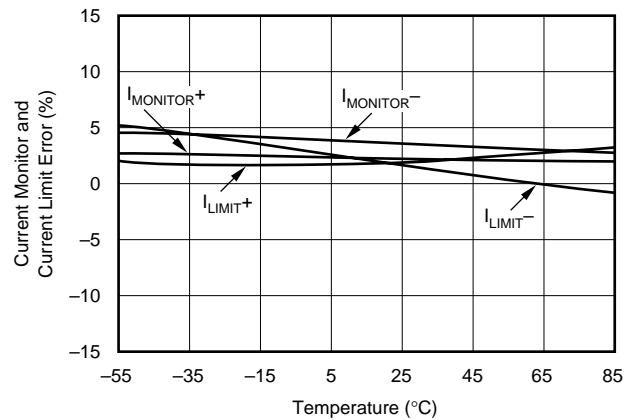

CURRENT MONITOR AND CURRENT LIMIT ERROR
vs OUTPUT CURRENT

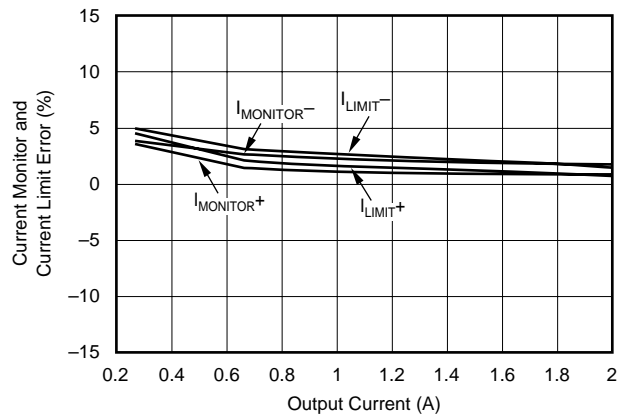

OVERSHOOT vs LOAD CAPACITANCE
($G = +1$, $R_L = 1\text{k}\Omega$)

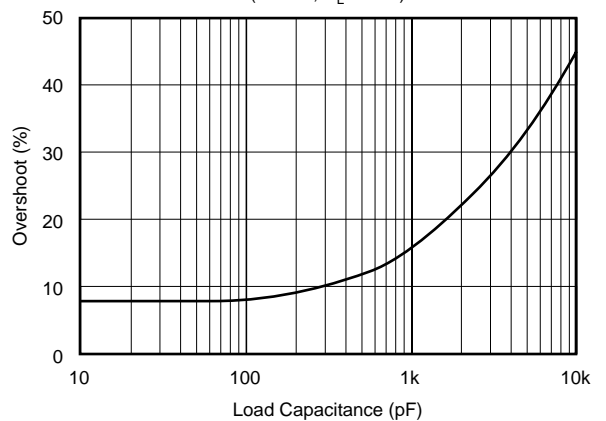

APPLICATIONS INFORMATION

BASIC CONFIGURATION

Figure 1 shows the OPA569 connected as a basic non-inverting amplifier; however, the OPA569 can be used in virtually any op amp configuration. A current limit setting resistor (R_{SET} , in Figure 1) is essential to the OPA569's operation, and cannot be omitted.

Power-supply terminals should be bypassed with low series impedance capacitors. Using a larger tantalum and smaller ceramic type in parallel is recommended. Power-supply wiring should have low series impedance.

POWER SUPPLIES

The OPA569 operates with excellent performance from a single (+2.7V to +5.5V) supply or from dual supplies. Power supply voltages do not need to be equal as long as the total voltage remains below 5.5V. Parameters that vary significantly with operating voltage are shown in the typical characteristics section.

ADJUSTABLE CURRENT LIMIT AND CURRENT LIMIT FLAG PIN

The OPA569 provides over-current protection to the load through its accurate, user-adjustable current limit (pin 3). The current limit value, I_{LIMIT} , can be set from 0.2A to 2.2A by controlling the current through the Current Limit Set pin. The current limit, I_{LIMIT} , will be $9800 I_{SET}$; where I_{SET} is the current through the Current Limit Set pin. Setting the current limit requires no special power resistors. The output current does not flow through this pin.

Setting the current limit

As illustrated in Figure 2, the simplest method of setting the current limit is to connect a resistor or potentiometer between

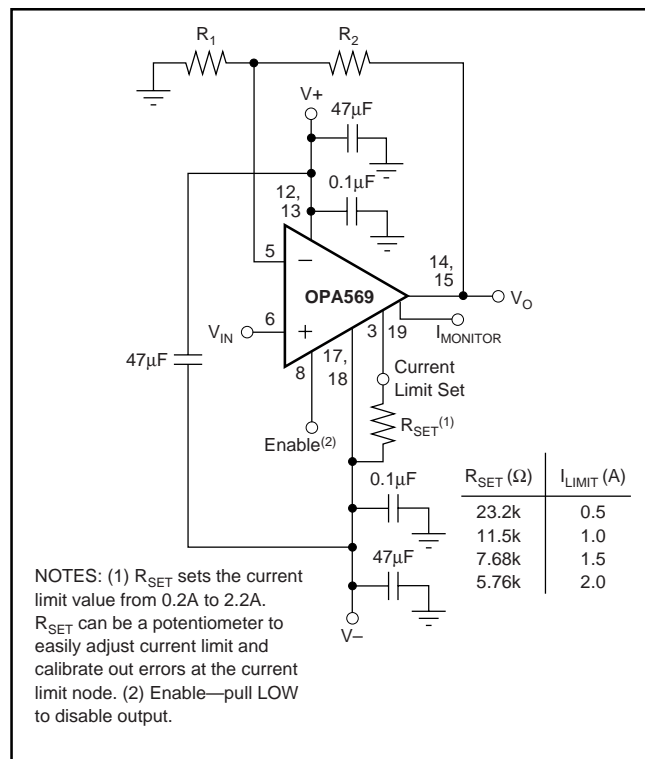

FIGURE 1. Basic Connections.

the current limit set pin and $V-$, the negative supply, according to the formula:

$$I_{LIMIT} = 9800 \cdot (1.18V/R_{SET})$$

Alternatively, the output current limit can be set by applying a voltage source in series with a resistance using the equation:

$$I_{LIMIT} = 9800 \cdot [(1.18V - V_{ADJUST})/R_{SET}]$$

The voltage source will be referenced to $V-$.

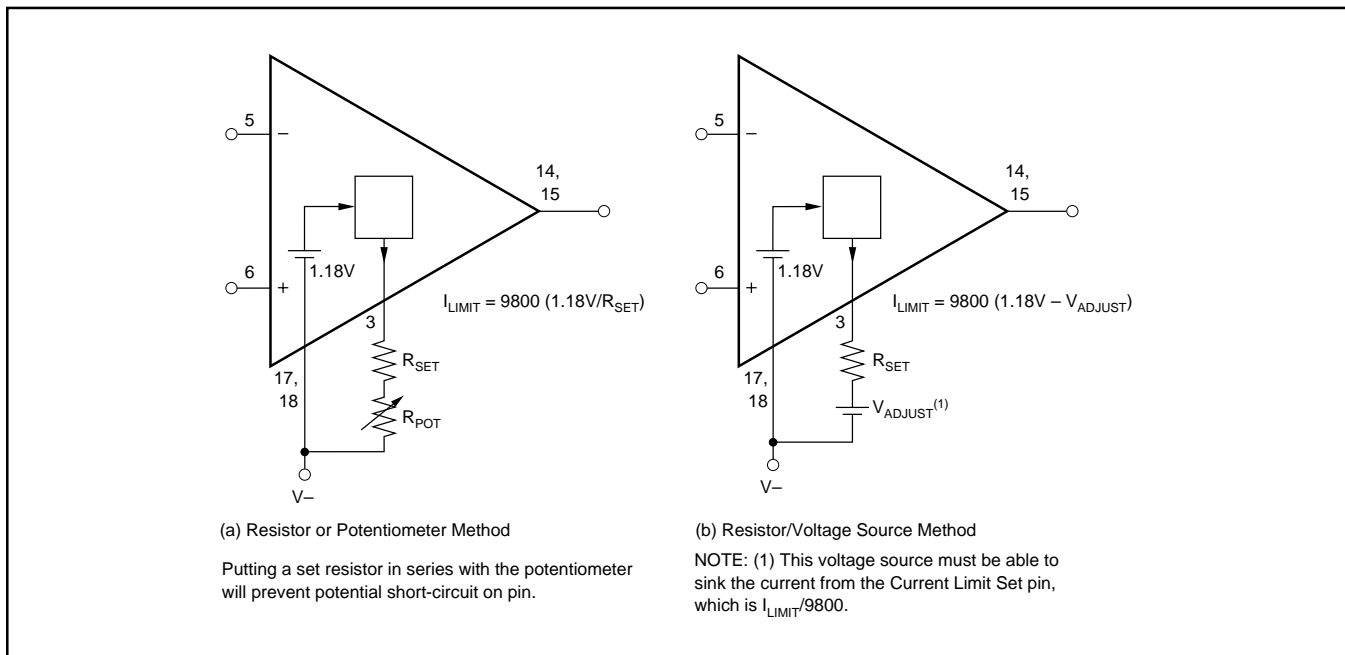

FIGURE 2. Setting the Current Limit—Resistor Method.

Current Limit Accuracy

Internally separate circuits monitor the positive and negative current limits. Each circuit output is compared to a single internal reference that is set by the user with an external resistor or a resistor/voltage source combination. The OPA569 employs a patented circuit technique to achieve an accurate and stable current limit throughout the full output range. The initial accuracy of the current limit is typically within 3%; however, due to internal matching limitations, the error can be as much as 15%. The variation of the current limit with factors such as output current level, output voltage and temperature is shown in the Typical Characteristics section.

When the accuracy of one current limit (sourcing or sinking) is more important than the other, it is possible to set its accuracy to better than 1% by adjusting the external resistor or the applied voltage. The accuracy of the other current limit will still be affected by internal matching.

Current Limit Flag Pin

The OPA569 features a Current Limit Flag pin (pin 4) that can be monitored to determine when the part is in current limit. The output signal of the current limit flag pin is compatible to standard logic in single supply applications. The output signal is a CMOS logic gate that switches from $V+$ to $V-$ to indicate that the amplifier is in current limit. This flag output pin can source and sink up to $25\mu\text{A}$. Additional parasitic capacitance between pins 3 and 4 can cause instability at the edge of the current limit. Avoid routing these traces in parallel close to each other.

Quiescent Current Dependence on the Current Limit Setting

The OPA569 is a low power amplifier, with a typical 3.4mA quiescent current (with the current limit configured for 200mA). The quiescent current varies with the current limit setting—it increases 0.5mA for each additional 200mA increase in the current limit, as shown in Figure 3.

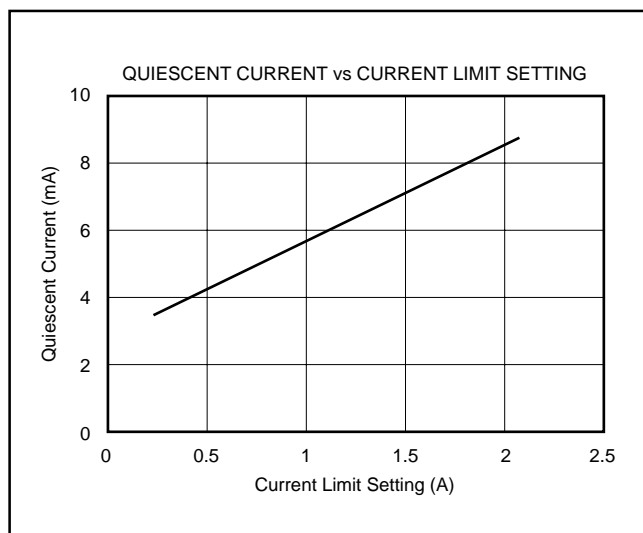

FIGURE 3. Quiescent Current vs Current Limit Setting.

CURRENT MONITOR

The OPA569 features an accurate output current monitor (I_{MONITOR}) without requiring the use of series resistance with the load. This increases efficiency significantly and provides better overall swing-to-supply performance.

An internal circuit creates a 1:475 copy of the output current. This copy of the output current can be monitored independently or it can be used in applications such as current control drive, setting non-symmetric positive and negative current limits or paralleling two or more devices for increased output current drive. When not being used, the Current Monitor pin may be left floating.

Some restrictions apply when using the current monitor function. When the main amplifier is sourcing current, the current monitor circuit must be sourcing current. Likewise, when the main amplifier is sinking current, the current monitor circuit must also be sinking current. Additionally, the swing on the I_{MONITOR} pin is smaller than the output swing. When the amplifier is sourcing current, the voltage of the Current Monitor pin must be at least two hundred millivolts less than the output voltage of the amplifier. Conversely, when the amplifier is sinking current, the voltage of the Current Monitor pin must be at least two hundred millivolts greater than the output voltage of the amplifier. Resistive loads are able to meet these restrictions. Other types of loads may cause invalid current monitor values.

A simple way to monitor the load current and meet these requirements is to connect a resistor (with resistance less than $400 \cdot R_L$) from the I_{MONITOR} pin to the same potential to which the other side of the load is connected. Another method is to use a transimpedance amplifier, as shown in Figure 4. This circuit must assure that the potential of the I_{MONITOR} pin remains in the valid voltage range by connecting it to the same potential to which the load is connected—most likely ground for dual supply or mid-supply for single-supply applications.

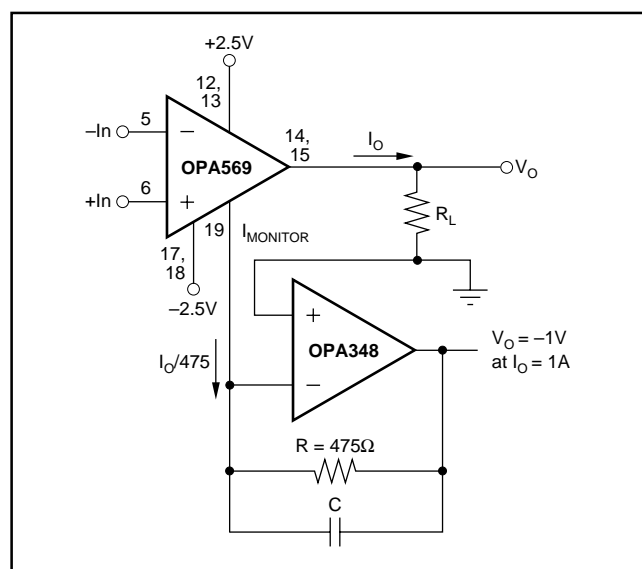

FIGURE 4. Transimpedance Amplifier to Monitor Load Current.

The accuracy of the current copy is reduced with small output currents. An internal circuit monitors the direction of the output current and enables the positive or the negative current monitoring circuitry accordingly. There is an approximate 20µs delay in the change of current direction. The switching point is near quiescent conditions and may cause current monitor inaccuracy with small output currents.

ENABLE PIN—OUTPUT DISABLE

The Enable pin can disable the OPA569 within microseconds. When disabled, the amplifier draws less than 10µA and its output enters a high-impedance state that allows multiplexing. It is important to note that when the amplifier is disabled, the Thermal Flag pin circuitry continues to operate. This feature allows use of the Thermal Flag pin output to implement thermal protection strategies. For more details, please see the section on thermal protection.

The OPA569 Enable pin has an internal pull-up circuit, so it does not have to be connected to the positive supply for normal operation. To disable the amplifier, the Enable pin must be connected to no more than $(V-) + 0.8V$. To enable the amplifier, either allow the Enable pin to float or connect it to at least $(V-) + 2.5V$.

The Enable pin is referenced to the negative supply ($V-$). Therefore, shutdown operation is slightly different in single-supply and dual-supply applications.

In single-supply operation, $V-$ typically equals common ground, thus the enable/disable logic signal and the OPA569 Enable pin are referenced to the same potential. In this configuration, the logic level and the OPA569 Enable pin can simply be tied together. Disable occurs for voltage levels of less than 0.8V. The OPA569 is enabled at logic levels greater than 2.5V.

In dual-supply operation, the logic level is referenced to a logic ground. However, the OPA569 Enable pin is still referenced to $V-$. To disable the OPA569, the voltage level of the logic signal needs to be level-shifted. This can be done using an optocoupler, as shown in Figure 5.

Examples of output behavior during disabled and enabled conditions with various load impedances are shown in the typical characteristics section. Please note that this behavior is a function of board layout, load impedances and bypass strategies. For sensitive loads, the use of a low-pass filter or other protection strategy is recommended.

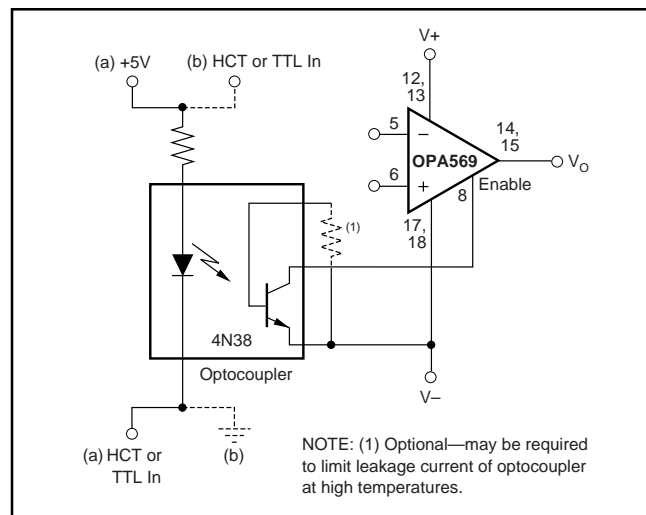

FIGURE 5. OPA569 Shutdown Configuration for Dual Supplies.

ENSURING MICROCONTROLLER COMPATIBILITY

Not all microcontrollers output the same logic state after power-up or reset. 8051-type microcontrollers, for example, output logic HIGH levels on their ports while other models power up with logic LOW levels after reset.

In configuration (a) shown in Figure 5, the enable/disable signal is applied on the cathode side of the photodiode within the optocoupler. A logic HIGH level causes the OPA569 to be enabled, and a logic LOW level disables the OPA569. In configuration (b) of Figure 5, with the logic signal applied on the anode side, a high level disables the OPA569 and a low level enables the op amp.

RAIL TO RAIL OUTPUT RANGE

The OPA569 has a class AB output stage with common source transistors that are used to achieve rail-to-rail output swing. It was designed to be able to swing closer to the rail than other existing linear amplifiers, even with high output current levels. A quick way to estimate the output swing with various output current requirements is by using the equation:

$$V_{\text{SWING}} [\text{typical}] = 0.1 \cdot I_O$$

Plots of the Output Swing vs Output Current, Supply Voltage, and Temperature are provided in the typical characteristics section.

RAIL TO RAIL INPUT RANGE

The input common-mode voltage range of the OPA569 extends 100mV beyond the supply rails. This is achieved by a complementary input stage with an N-channel input differential pair in parallel with a P-channel differential pair. The N-channel input pair is active for input voltages close to the positive rail while the P-channel input pair is active for input voltages close to the negative rail. The transition point is typically at $(V+) - 1.3V$, and there is a small transition region around the switching point where both transistors are on. It is important to note that the two input pairs can have offsets of different signs and magnitudes. Therefore, as the transition point is crossed, the offset of the amplifier changes. This offset shift accounts for the reduced common-mode rejection ratio over the full input common-mode range.

OUTPUT PROTECTION

Reactive and EMF-generating loads can return load current to the amplifier, causing the output voltage to exceed the power-supply voltage. This damaging condition can be avoided with clamp diodes from the output terminal to the power supplies, as shown in Figure 6. Schottky rectifier diodes with a 3A or greater continuous rating are recommended.

THERMAL FLAG PIN

The OPA569 has thermal sensing circuitry that provides a warning signal when the die temperature exceeds safe limits. Unless the Thermal Flag is connected to the Enable pin, when this flag is triggered, the part continues to operate even

though the junction temperature exceeds $150^{\circ}C$. This allows maximum usable operation in very harsh conditions but degrades reliability. The Thermal Flag pin can be used to provide for orderly system shutdown before failure occurs. It can be also used to evaluate the thermal environment to determine need for and appropriate design of a shutdown mechanism.

The thermal flag output signal is from a CMOS logic gate that switches from $V+$ to $V-$ to indicate that the amplifier is in thermal limit. This flag output pin can source and sink up to $25\mu A$. The Thermal Flag pin is HIGH during normal operation. Power dissipated in the amplifier will cause the junction temperature to rise. When the junction temperature exceeds $150^{\circ}C$, the Thermal Flag pin will go LOW, and remain LOW until the amplifier has cooled to $130^{\circ}C$. Despite this hysteresis, with a method of orderly shutdown, the Thermal Flag pin can cycle on and off, depending on load and signal conditions. This limits the dissipation of the amplifier but may have an undesirable effect on the load. This temperature range exceeds the absolute maximum temperature rating and is intended to protect the device from excessive temperatures that can cause damage. Brief and infrequent excursions in this temperature range are likely to be tolerated, but are not recommended.

It is possible to connect the Thermal Flag pin directly to the Enable pin for automatic shutdown protection. When both thermal shutdown and the amplifier enable/disable functions are desired, the externally generated control signal and the Thermal Flag pin outputs should be combined with an AND gate, as shown on Figure 7. The temperature protection was designed to protect against overload conditions. It was not intended to replace proper heatsinking. Continuously running the OPA569 in and out of thermal shutdown will degrade reliability.

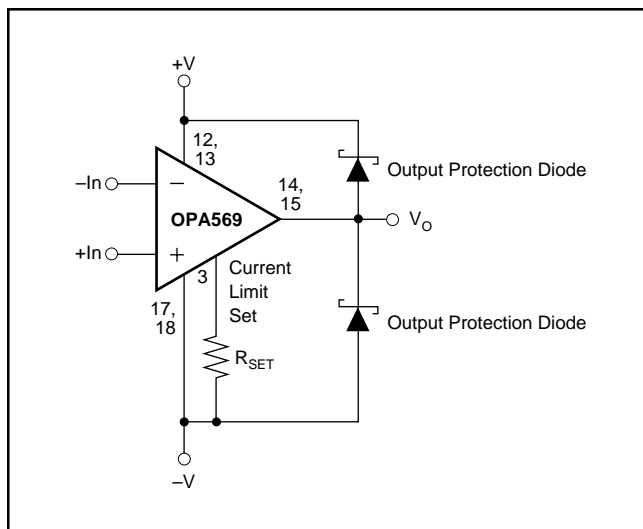

FIGURE 6. Output Protection Diode.

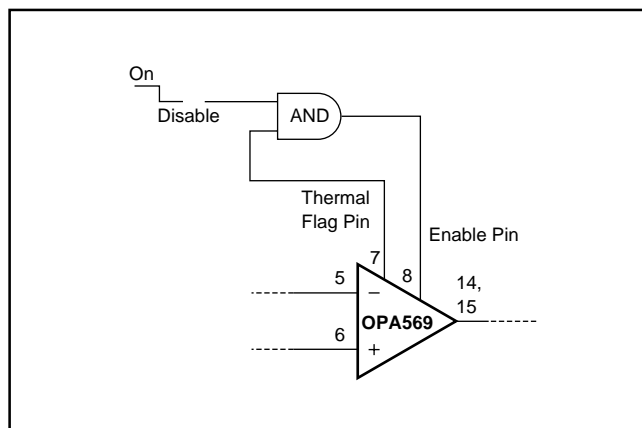

FIGURE 7. Enable/Shutdown Control Using Thermal Flag Pin and External Control Signal.

Any tendency to activate the thermal protection circuit indicates excessive power dissipation or an inadequate heat sink. For reliable, long term, continuous operation, the junction temperature should be limited to 125°C maximum. To estimate the margin of safety in a complete design (including heat sink), increase the ambient temperature until the thermal protection is triggered. Use worst-case loading and signal conditions. For good, long-term reliability, thermal protection should trigger more than 25°C above the maximum expected ambient conditions of your application. This produces a junction temperature of 125°C at the maximum expected ambient condition.

Fast transients of large output current swings (for example switching quickly from sourcing 2A to sinking 2A) may cause a glitch on the Thermal Flag pin. When switching large currents is expected, the use of extra bypass between the supplies or a low-pass filter on the Thermal Flag pin is recommended.

POWER DISSIPATION AND SAFE OPERATING AREA

Power dissipation depends on power supply, signal and load conditions. It is dominated by the power dissipation of the output transistors. For DC signals, power dissipation is equal to the product of output current, I_{OUT} and the output voltage across the conducting output transistor ($V_S - V_{OUT}$). Dissipation with AC signals is lower. Application Bulletin AB-039 (SBOA022) explains how to calculate or measure power dissipation with unusual signals and loads and can be found at the TI web site (www.ti.com).

Output short-circuits are particularly demanding for the amplifier because the full supply voltage is seen across the conducting transistor. It is very important to note that the temperature protection will not shut the part down in over-temperature conditions, unless the Thermal Flag pin is connected to the Enable pin; see the section on Thermal Flag. Figure 8 shows the safe operating area at room temperature with various heatsinking efforts. Note that the safe output current decreases as ($V_S - V_{OUT}$) increases. Figure 9 shows the safe operating area at various temperatures with the PowerPAD being soldered to a 2 oz copper pad.

The power that can be safely dissipated in the package is related to the ambient temperature and the heatsink design. The PowerPAD package was specifically designed to provide excellent power dissipation, but board layout greatly influences the heat dissipation of the package. Refer to the "PowerPAD Thermally Enhanced Package" section for further details.

The OPA569 has a junction-to-ambient thermal resistance (θ_{JA}) value of 21.6°C/W when soldered to 2oz copper plane. This value can be further decreased to 12°C/W by the addition of forced air. Figure 10 shows the junction-to-ambient thermal resistance of the DWP-20 package.

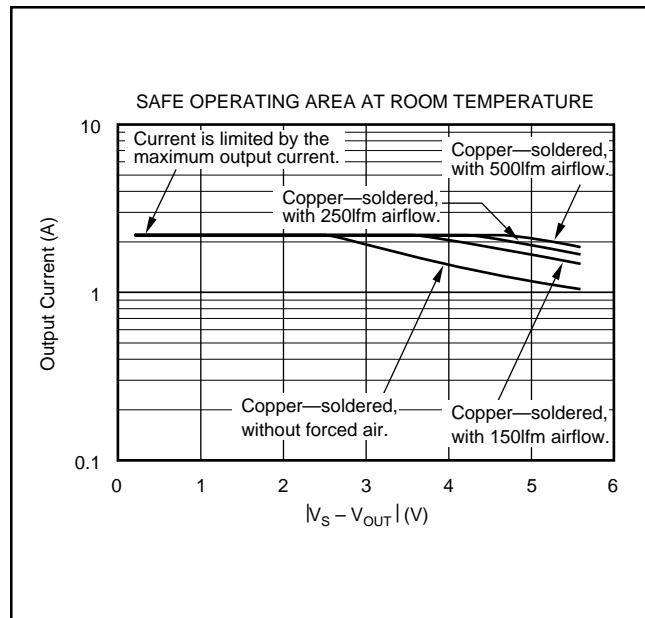

FIGURE 8. Safe Operating Area at Room Temperature.

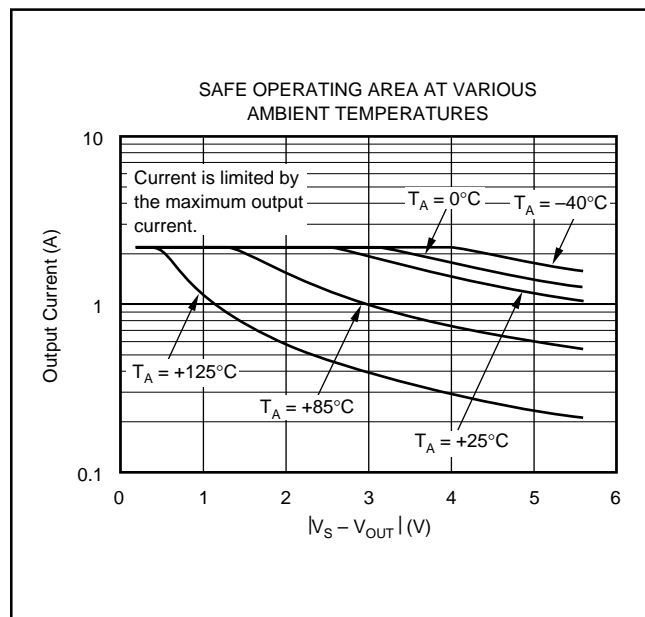

FIGURE 9. Safe Operating Area at Various Ambient Temperatures. PowerPAD soldered to a 2oz copper pad.

HEATSINKING METHOD	θ_{JA}
The part is soldered to a 2 oz copper pad under the exposed pad.	21.6
Soldered to copper pad with forced airflow (150lfm).	15.1
Soldered to copper pad with forced airflow (250lfm).	13.2
Soldered to copper pad with forced airflow (500lfm).	12.0

FIGURE 10. Junction-to-Ambient Thermal Resistance with Various Heatsinking Efforts.

Junction temperature should be kept below 125°C for reliable operation. The junction temperature can be calculated by:

$$T_J = T_A + P_D \theta_{JA}$$

where $\theta_{JA} = \theta_{JC} + \theta_{CA}$

T_J = Junction Temperature (°C)

T_A = Ambient Temperature (°C)

P_D = Power Dissipated (W)

θ_{JA} = Junction-to-Ambient Thermal Resistance

θ_{JC} = Junction-to-Case Thermal Resistance

θ_{CA} = Case-to-Air Thermal Resistance

The Maximum Power Dissipation vs Temperature for the heatsinking methods listed in Figure 10 is shown in Figure 11.

To appropriately determine required heatsink area, required power dissipation should be calculated and the relationship between power dissipation and thermal resistance should be considered to minimize shutdown conditions and allow for proper long-term operation (junction temperature of 125°C). Once the heatsink area has been selected, worst-case load conditions should be tested to ensure proper thermal protection.

For applications with limited board size, refer to Figure 12 for the approximate thermal resistance relative to heatsink area. Increasing the heatsink area beyond 2in² provides little improvement in thermal resistance. To achieve the 21.5°C/W stated in the Electrical Characteristics, a copper plane size of 9in² was used. The SO-20 PowerPAD package is well suited for continuous power levels, as shown in Figure 11. Higher power levels may be achieved in applications with a low on/off duty cycle.

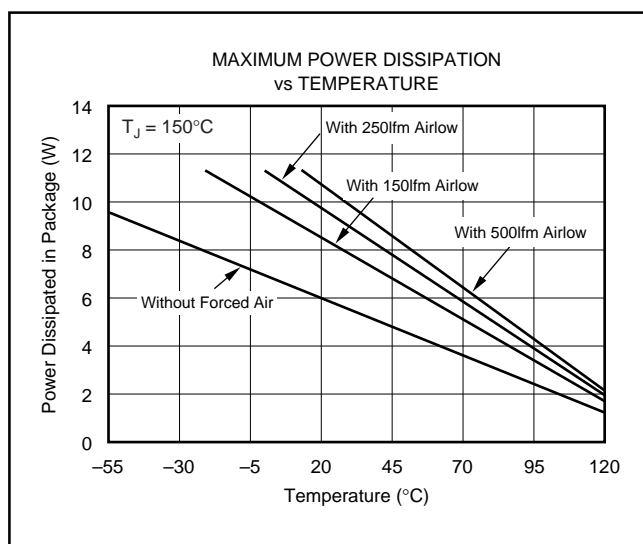

FIGURE 11. Maximum Power Dissipation vs Temperature.

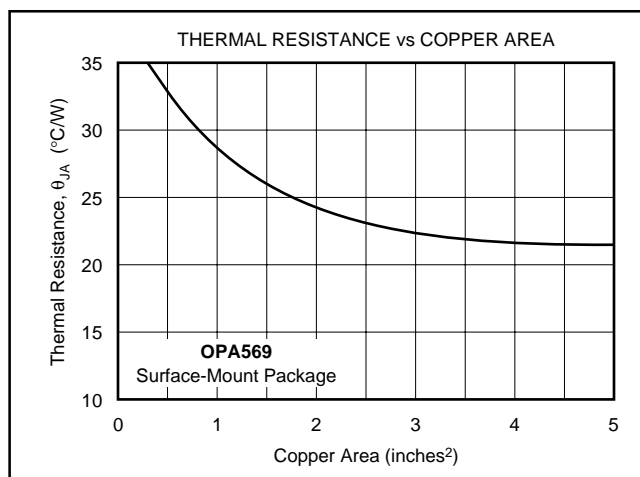

FIGURE 12. Thermal Resistance vs Circuit Board Copper Area.

FEEDBACK CAPACITOR IMPROVES RESPONSE

For optimum settling time and stability with higher impedance feedback networks ($R_F > 50k\Omega$), it may be necessary to add a feedback capacitor across the feedback resistor, R_F , as shown in Figure 13. This capacitor compensates for the zero created by the feedback network impedance and the OPA569 input capacitance (and any parasitic layout capacitance). The effect becomes more significant with higher impedance networks.

The size of the capacitor needed is estimated using the equation:

$$R_{IN} \cdot C_{IN} = R_F \cdot C_F$$

where C_{IN} is the sum of the input capacitance of the OPA569 plus the parasitic layout capacitance.

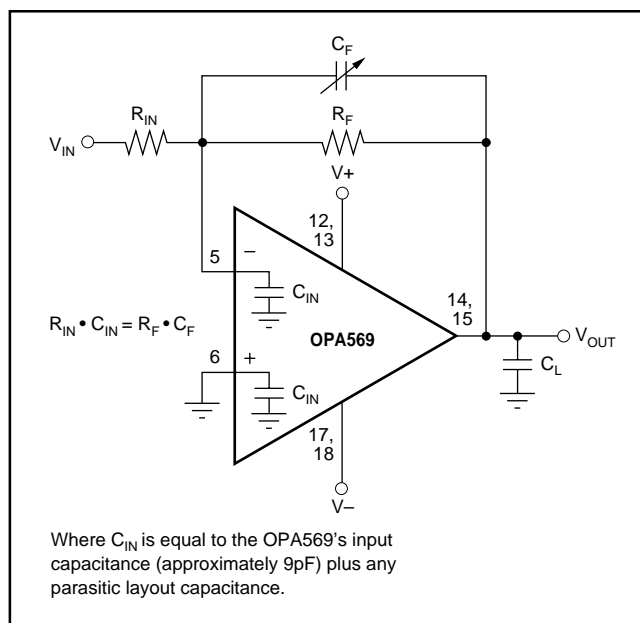

FIGURE 13. Feedback Capacitor for use with Higher Impedance Networks.

PARALLEL OPERATION

The OPA569 allows parallel operation of multiple op amps to extend output current capability or improve the output voltage swing to the rail. Special internal circuitry causes the load current to be shared equally between two (or more) op amps.

Figure 14 shows two ways to connect the input terminals. When the amplifier inputs are connected in parallel, the effective offset voltage is averaged and the bandwidth and slew rate performance are the same as that of a single amplifier. It is also possible to use one amplifier to be the “master” and connect the other inputs to a voltage within the common-mode input range of the amplifier; however, slew rate and bandwidth performance will be degraded.

For best performance, keep additional capacitance at the Parallel Out pins to a minimum and avoid routing these lines close to other lines that might see large voltage swings.

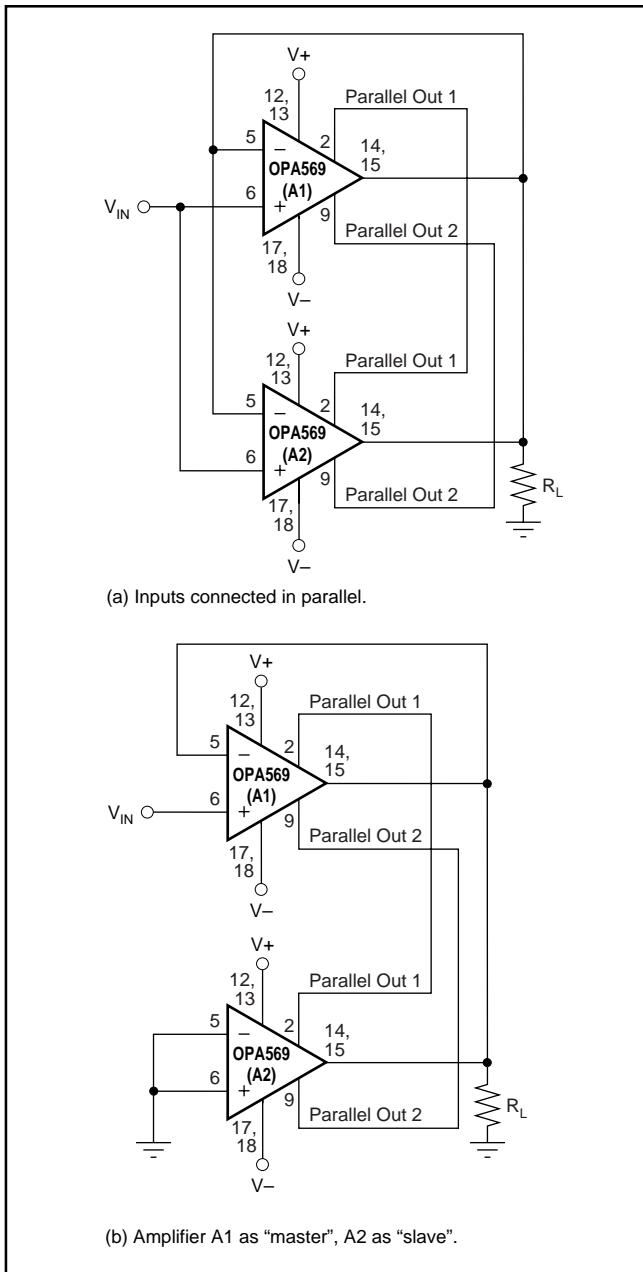

FIGURE 14. Parallel Operation.

PowerPAD THERMALLY ENHANCED PACKAGE

The OPA569 uses the SO-20 PowerPAD package, a thermally enhanced, standard size IC package designed to eliminate the use of bulky heatsinks and slugs traditionally used in thermal packages. This package can be easily mounted using standard PCB assembly techniques.

The PowerPAD package is designed so that the leadframe die pad (or thermal pad) is exposed on the bottom of the IC, as shown in Figure 15. This provides an extremely low thermal resistance (θ_{JC}) path between the die and the exterior of the package. The thermal pad on the bottom of the IC can then be soldered directly to the PCB, using the PCB as a heatsink. In addition, plated-through holes (vias) provide a low thermal resistance heat flow path to the back side of the PCB.

Soldering the PowerPAD to the PCB is always recommended, even with applications that have low power dissipation. This provides the necessary thermal and mechanical connection between the leadframe die pad and the PCB.

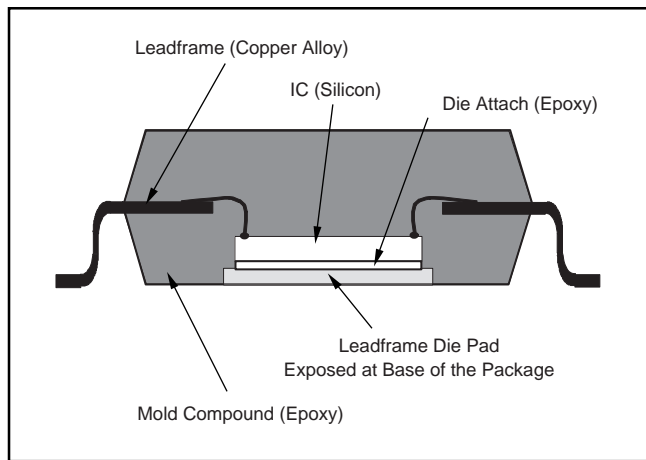

FIGURE 15. Section View of a PowerPAD Package.

PowerPAD Assembly Process

1. The PowerPAD must be connected to the most negative supply voltage of the device, which will be ground in single-supply applications and V^- in split-supply applications.
2. Prepare the PCB with a top-side etch pattern, as shown in Figure 16. There should be etch for the leads as well as etch for the thermal land.
3. Place the recommended number of plated-through holes (or thermal vias) in the area of the thermal pad. These holes should be 13 mils in diameter. They are kept small so that solder wicking through the holes is not a problem during reflow. The minimum recommended number of holes for the SO-20 PowerPAD package is 24, as shown in Figure 16.
4. It is recommended, but not required, to place a small number of additional holes under the package and outside the thermal pad area. These holes provide an additional heat path between the copper land and the ground plane. They may be larger because they are not in the area to be soldered, so wicking is not a problem. This is illustrated in Figure 16.

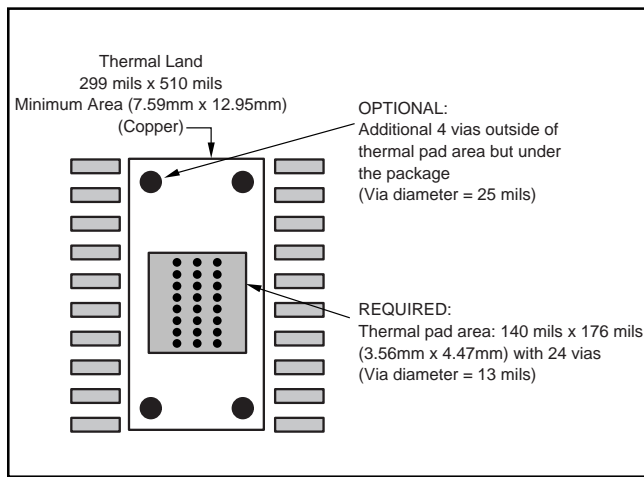

FIGURE 16. 20-Pin DWP PowerPAD PCB Etch and Via Pattern.

5. Connect all holes, including those within the thermal pad area and outside the pad area, to the internal ground plane or other internal copper plane for single supply applications, and V^- for split-supply applications.
6. When laying out these holes to the ground plane, do not use the typical web or spoke via connection methodology, as shown in Figure 17. Web connections have a high thermal resistance connection that is useful for slowing the heat transfer during soldering operations. This makes soldering the vias that have ground plane connections easier. However, in this application, low thermal resistance is desired for the most efficient heat transfer. Therefore, the holes under the PowerPAD package should make their connection to the internal ground plane with a complete connection around the entire circumference of the plated-through hole.

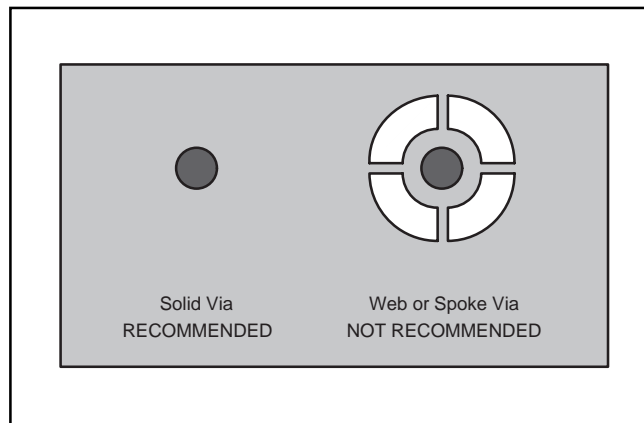

FIGURE 17. Via Connection.

7. The top-side solder mask should leave the terminals of the pad connections and the thermal pad area exposed. The thermal pad area should leave the 13 mil holes exposed. The larger holes outside the thermal pad area should be covered with solder mask.
8. Apply solder paste to the exposed thermal pad area and all of the package terminals.

9. With these preparatory steps in place, the PowerPAD IC is simply placed in position and run through the solder reflow operation as any standard surface-mount component. This results in a part that is properly installed.

For detailed information on the PowerPAD package including thermal modeling considerations and repair procedures, please see Technical Brief SLMA002, "PowerPAD Thermally Enhanced Package," located at www.ti.com.

LAYOUT GUIDELINES

The OPA569 is a power amplifier that requires proper layout for best performance. Figure 18 shows an example layout. Refinements to this example layout may be required based on assembly process requirements.

Keep power-supply leads as short as possible. This will keep inductance low and resistive losses at a minimum. A minimum of 18 gauge wire thickness is recommended for power-supply leads. The wire length should be less than 8 inches.

Proper power-supply bypassing with low ESR capacitors is essential to achieve good performance. A parallel combination of 100nF ceramic and 47 μ F tantalum bypass capacitors will provide low impedance over a wide frequency range. Bypass capacitors should be placed as close as practical to the power-supply pins of the OPA569.

PCB traces conducting high currents, such as from output to load or from the power-supply connector to the power-supply pins of the OPA569 should be kept as wide and short as possible.

The twenty-four holes in the landing pattern for the OPA569 are for the thermal vias that connect the PowerPAD of the OPA569 to the heatsink area on the PCB. The additional four larger vias further enhance the heat conduction into the heatsink area. All traces conducting high currents are very wide for lowest inductance and minimal resistive losses. Note that the negative supply ($-V$) pin on the OPA569 can be connected through the PowerPAD to allow for maximum trace width for high current paths.

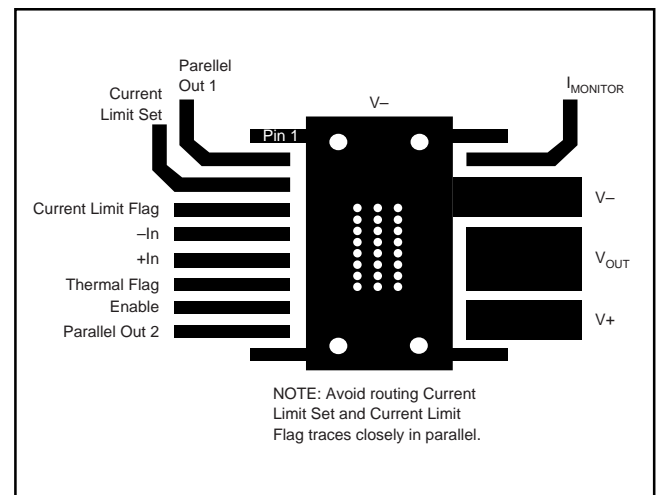

FIGURE 18. 20-Pin DWP PowerPAD PCB Etch and Via Pattern.

APPLICATION CIRCUITS

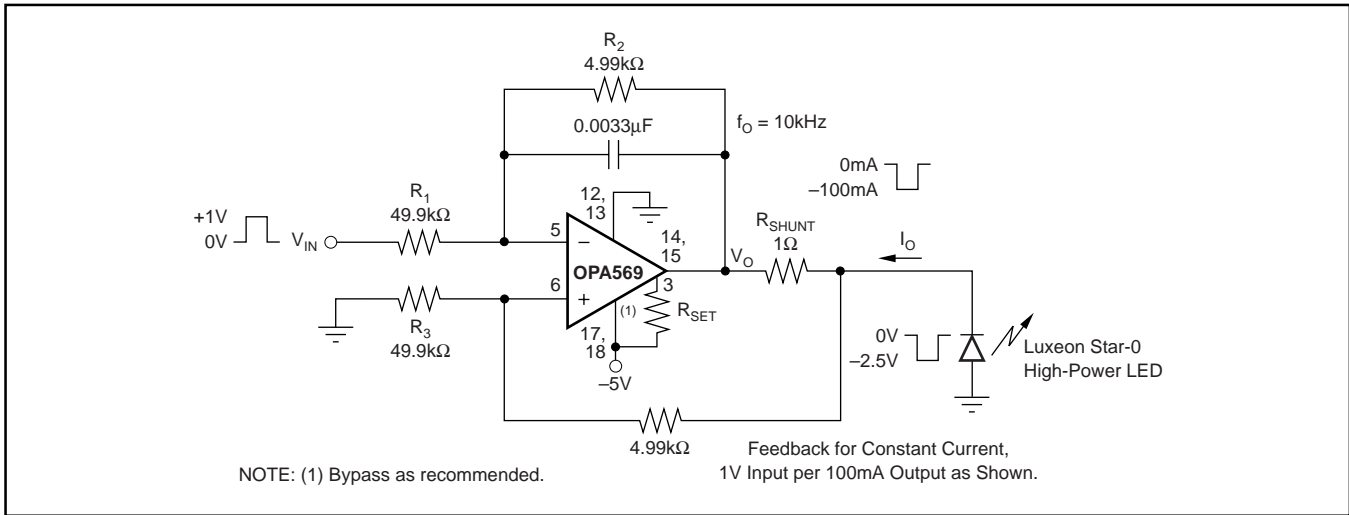

FIGURE 19. Grounded Anode LED Driver.

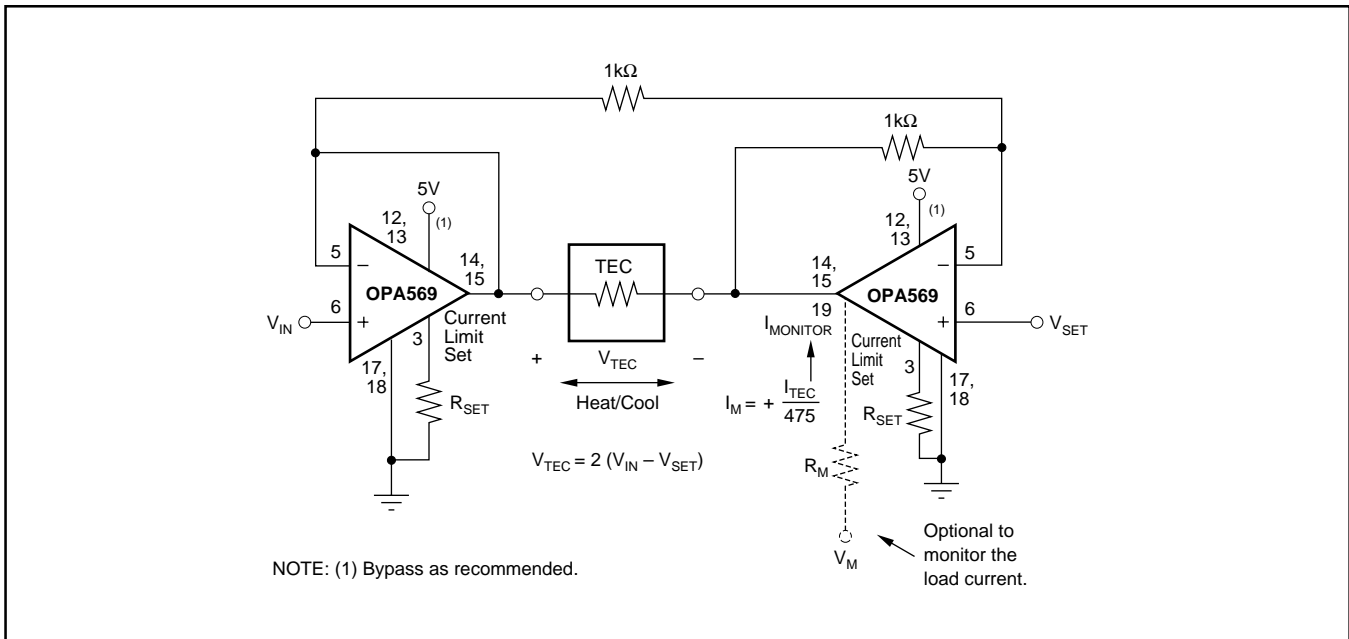

FIGURE 20. Bridge Tied Load Driver.

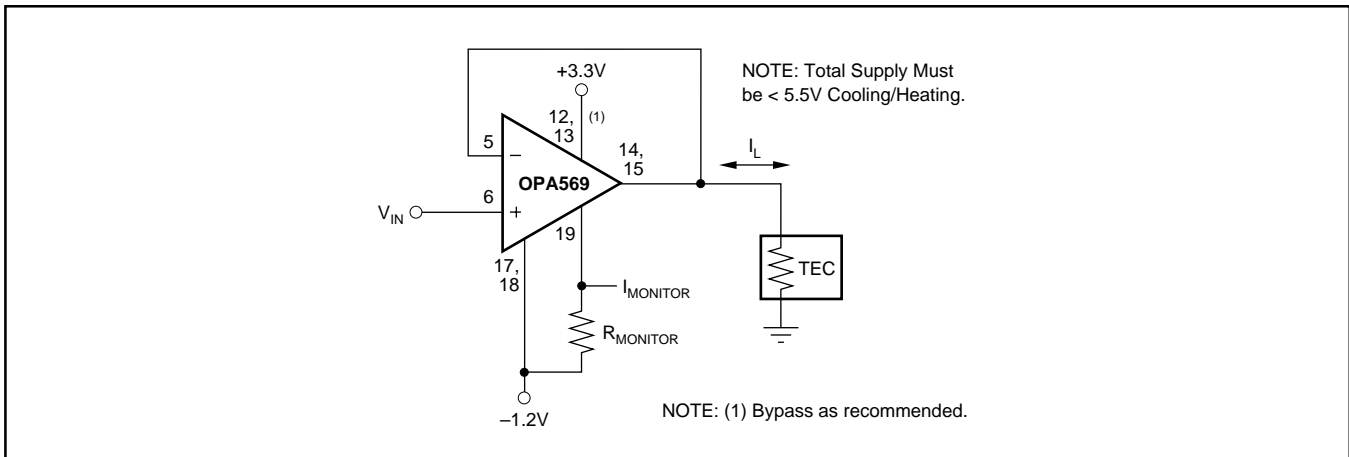

FIGURE 21. Single Power Amplifier Driving Bidirectional Current through a TEC using Asymmetrical Bipolar Power Supplies.

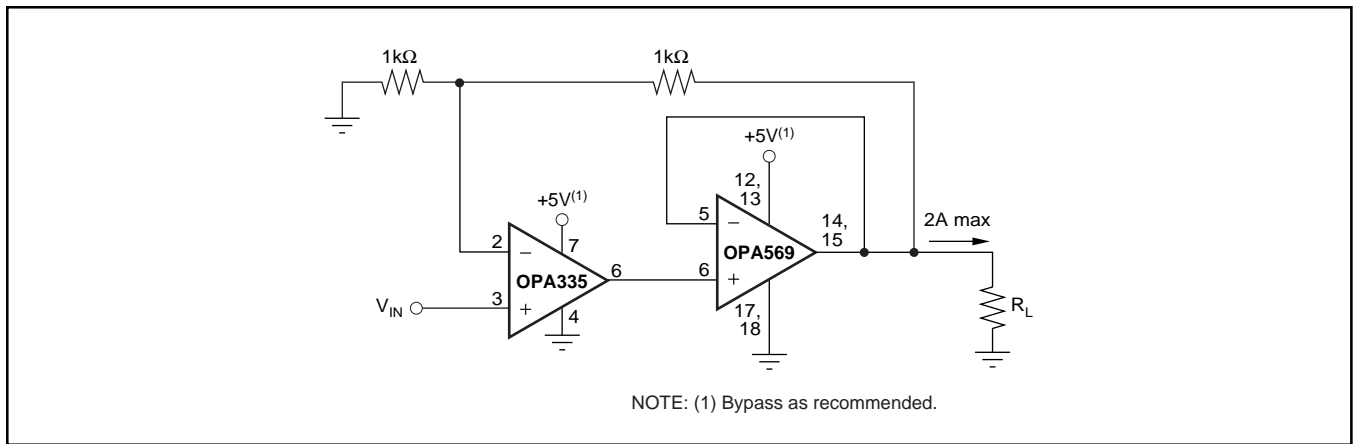

FIGURE 22. Power Booster for Precision Op Amp.

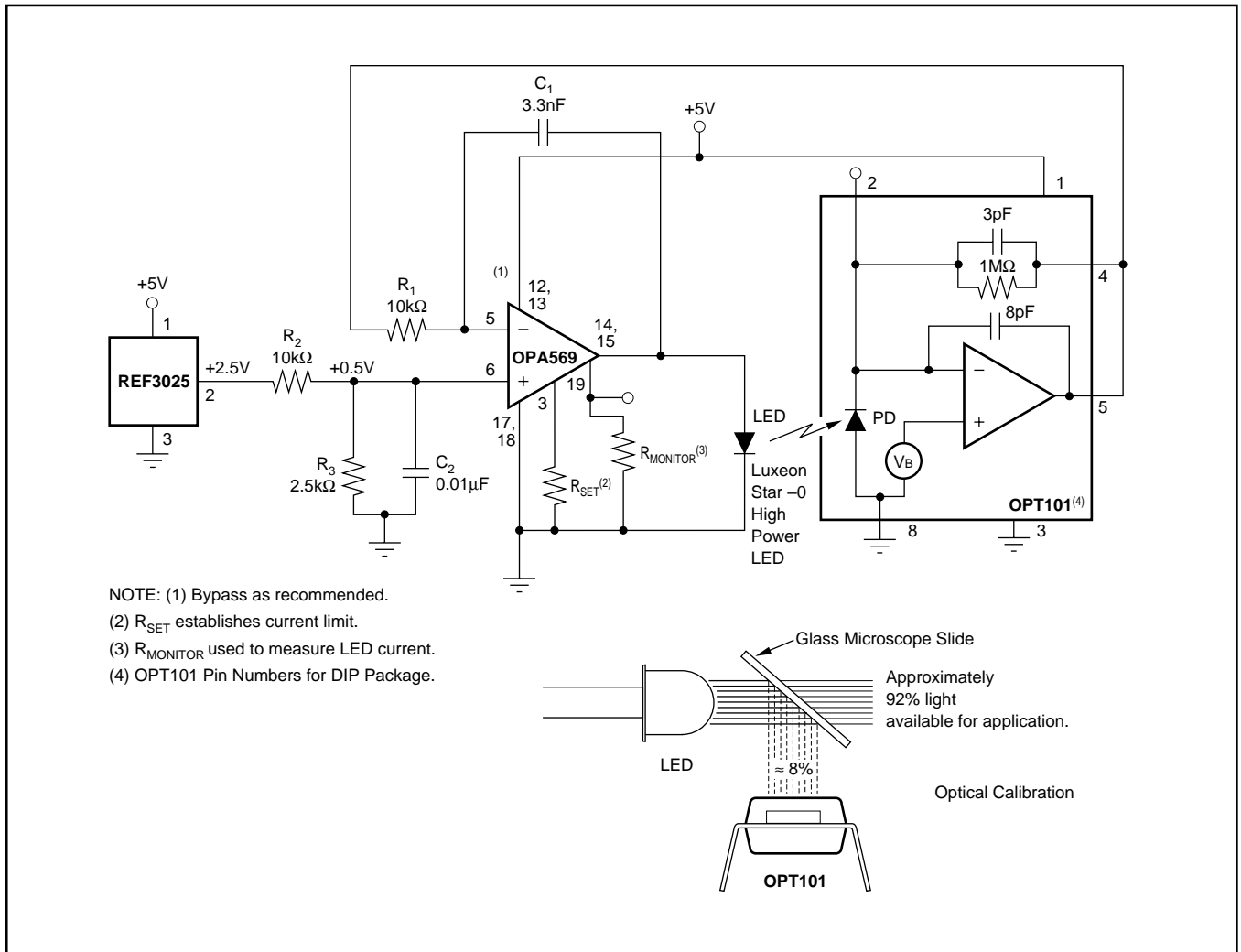

FIGURE 23. LED Output Regulation Circuit for Constant Optical Power.

PACKAGING INFORMATION

Orderable Device	Status (1)	Package Type	Package Drawing	Pins	Package Qty	Eco Plan (2)	Lead/Ball Finish (6)	MSL Peak Temp (3)	Op Temp (°C)	Device Marking (4/5)	Samples
OPA569AIDWP	ACTIVE	SO PowerPAD	DWP	20	25	Green (RoHS & no Sb/Br)	CU NIPDAU	Level-2-260C-1 YEAR	-55 to 125	OPA569A	Samples
OPA569AIDWPR	ACTIVE	SO PowerPAD	DWP	20	1000	Green (RoHS & no Sb/Br)	CU NIPDAU	Level-2-260C-1 YEAR	-55 to 125	OPA569A	Samples

(1) The marketing status values are defined as follows:

ACTIVE: Product device recommended for new designs.

LIFEBUY: TI has announced that the device will be discontinued, and a lifetime-buy period is in effect.

NRND: Not recommended for new designs. Device is in production to support existing customers, but TI does not recommend using this part in a new design.

PREVIEW: Device has been announced but is not in production. Samples may or may not be available.

OBsolete: TI has discontinued the production of the device.

(2) **RoHS:** TI defines "RoHS" to mean semiconductor products that are compliant with the current EU RoHS requirements for all 10 RoHS substances, including the requirement that RoHS substance do not exceed 0.1% by weight in homogeneous materials. Where designed to be soldered at high temperatures, "RoHS" products are suitable for use in specified lead-free processes. TI may reference these types of products as "Pb-Free".

RoHS Exempt: TI defines "RoHS Exempt" to mean products that contain lead but are compliant with EU RoHS pursuant to a specific EU RoHS exemption.

Green: TI defines "Green" to mean the content of Chlorine (Cl) and Bromine (Br) based flame retardants meet JS709B low halogen requirements of <=1000ppm threshold. Antimony trioxide based flame retardants must also meet the <=1000ppm threshold requirement.

(3) MSL, Peak Temp. - The Moisture Sensitivity Level rating according to the JEDEC industry standard classifications, and peak solder temperature.

(4) There may be additional marking, which relates to the logo, the lot trace code information, or the environmental category on the device.

(5) Multiple Device Markings will be inside parentheses. Only one Device Marking contained in parentheses and separated by a "~" will appear on a device. If a line is indented then it is a continuation of the previous line and the two combined represent the entire Device Marking for that device.

(6) Lead/Ball Finish - Orderable Devices may have multiple material finish options. Finish options are separated by a vertical ruled line. Lead/Ball Finish values may wrap to two lines if the finish value exceeds the maximum column width.

Important Information and Disclaimer:The information provided on this page represents TI's knowledge and belief as of the date that it is provided. TI bases its knowledge and belief on information provided by third parties, and makes no representation or warranty as to the accuracy of such information. Efforts are underway to better integrate information from third parties. TI has taken and continues to take reasonable steps to provide representative and accurate information but may not have conducted destructive testing or chemical analysis on incoming materials and chemicals. TI and TI suppliers consider certain information to be proprietary, and thus CAS numbers and other limited information may not be available for release.

In no event shall TI's liability arising out of such information exceed the total purchase price of the TI part(s) at issue in this document sold by TI to Customer on an annual basis.

TAPE AND REEL INFORMATION

QUADRANT ASSIGNMENTS FOR PIN 1 ORIENTATION IN TAPE

*All dimensions are nominal

Device	Package Type	Package Drawing	Pins	SPQ	Reel Diameter (mm)	Reel Width W1 (mm)	A0 (mm)	B0 (mm)	K0 (mm)	P1 (mm)	W (mm)	Pin1 Quadrant
OPA569AIDWPR	SO Power PAD	DWP	20	1000	330.0	24.4	10.8	13.3	2.7	12.0	24.0	Q1

TAPE AND REEL BOX DIMENSIONS



*All dimensions are nominal

Device	Package Type	Package Drawing	Pins	SPQ	Length (mm)	Width (mm)	Height (mm)
OPA569AIDWPR	SO PowerPAD	DWP	20	1000	367.0	367.0	45.0

DWP (R-PDSO-G**)

PowerPAD™ PLASTIC SMALL-OUTLINE PACKAGE

20 PINS SHOWN

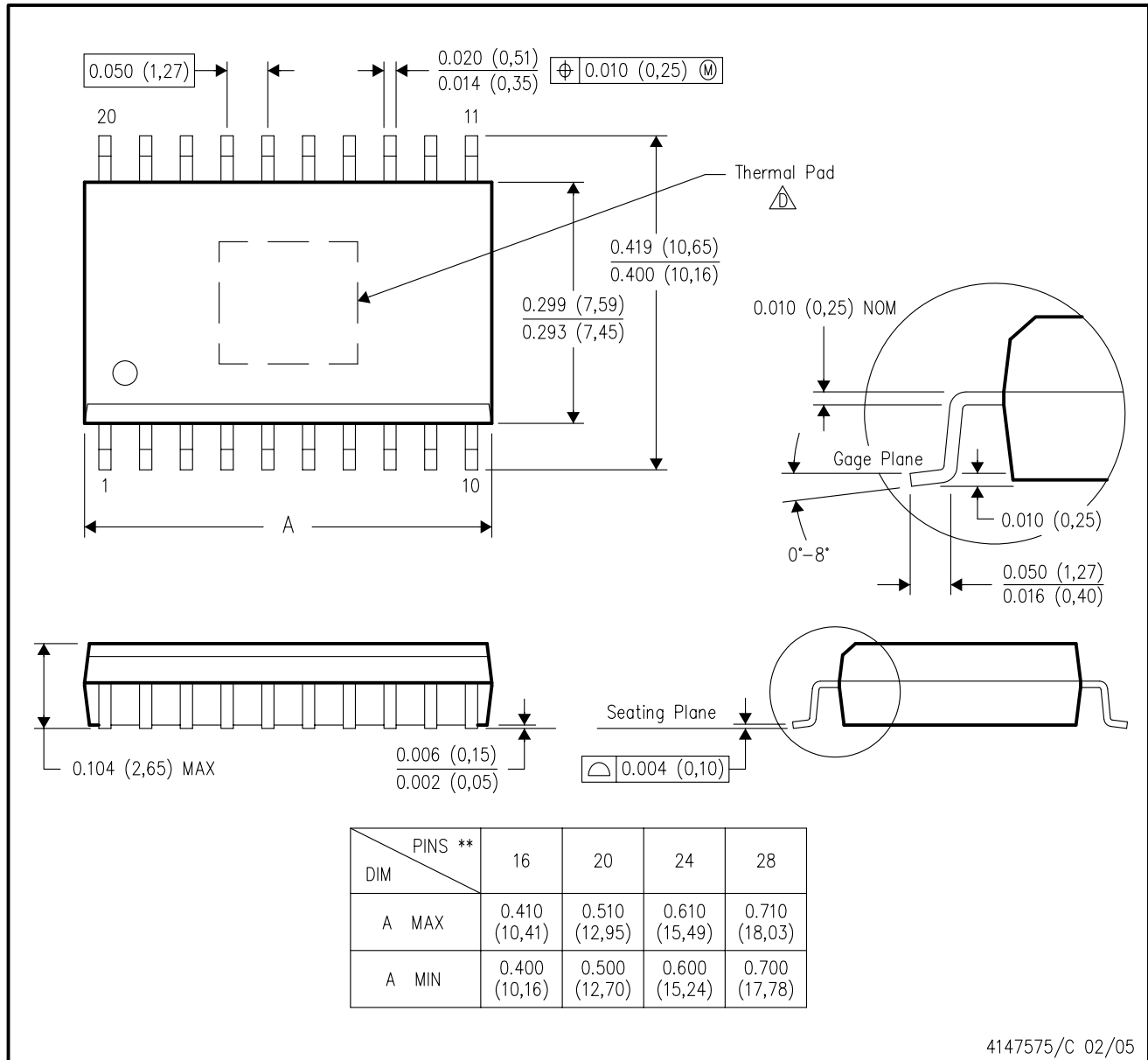

- NOTES:
- A. All linear dimensions are in inches (millimeters).
 - B. This drawing is subject to change without notice.
 - C. Body dimensions do not include mold flash or protrusion not to exceed 0.006 (0,15).
- Δ This package is designed to be soldered to a thermal pad on the board. Refer to Technical Brief, PowerPad Thermally Enhanced Package, Texas Instruments Literature No. SLMA002 for information regarding recommended board layout. This document is available at www.ti.com <<http://www.ti.com>>. See the product data sheet for details regarding the exposed thermal pad dimensions.

PowerPAD is a trademark of Texas Instruments.

THERMAL PAD MECHANICAL DATA

DWP (R-PDSO-G20)

PowerPAD™ PLASTIC SMALL OUTLINE

THERMAL INFORMATION

This PowerPAD™ package incorporates an exposed thermal pad that is designed to be attached to a printed circuit board (PCB). The thermal pad must be soldered directly to the PCB. After soldering, the PCB can be used as a heatsink. In addition, through the use of thermal vias, the thermal pad can be attached directly to the appropriate copper plane shown in the electrical schematic for the device, or alternatively, can be attached to a special heatsink structure designed into the PCB. This design optimizes the heat transfer from the integrated circuit (IC).

For additional information on the PowerPAD package and how to take advantage of its heat dissipating abilities, refer to Technical Brief, PowerPAD Thermally Enhanced Package, Texas Instruments Literature No. SLMA002 and Application Brief, PowerPAD Made Easy, Texas Instruments Literature No. SLMA004. Both documents are available at www.ti.com.

The exposed thermal pad dimensions for this package are shown in the following illustration.

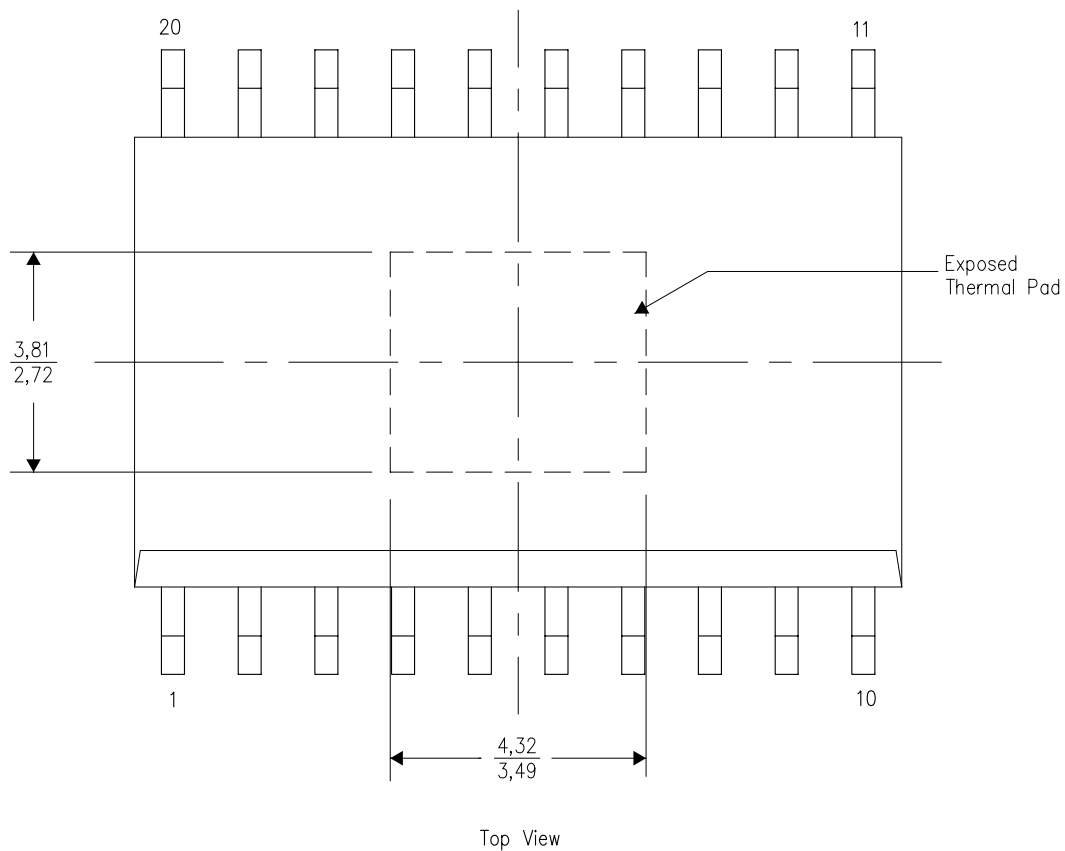

4206325-2/E 12/10

NOTE: A. All linear dimensions are in millimeters

IMPORTANT NOTICE

Texas Instruments Incorporated (TI) reserves the right to make corrections, enhancements, improvements and other changes to its semiconductor products and services per JESD46, latest issue, and to discontinue any product or service per JESD48, latest issue. Buyers should obtain the latest relevant information before placing orders and should verify that such information is current and complete.

TI's published terms of sale for semiconductor products (<http://www.ti.com/sc/docs/stdterms.htm>) apply to the sale of packaged integrated circuit products that TI has qualified and released to market. Additional terms may apply to the use or sale of other types of TI products and services.

Reproduction of significant portions of TI information in TI data sheets is permissible only if reproduction is without alteration and is accompanied by all associated warranties, conditions, limitations, and notices. TI is not responsible or liable for such reproduced documentation. Information of third parties may be subject to additional restrictions. Resale of TI products or services with statements different from or beyond the parameters stated by TI for that product or service voids all express and any implied warranties for the associated TI product or service and is an unfair and deceptive business practice. TI is not responsible or liable for any such statements.

Buyers and others who are developing systems that incorporate TI products (collectively, "Designers") understand and agree that Designers remain responsible for using their independent analysis, evaluation and judgment in designing their applications and that Designers have full and exclusive responsibility to assure the safety of Designers' applications and compliance of their applications (and of all TI products used in or for Designers' applications) with all applicable regulations, laws and other applicable requirements. Designer represents that, with respect to their applications, Designer has all the necessary expertise to create and implement safeguards that (1) anticipate dangerous consequences of failures, (2) monitor failures and their consequences, and (3) lessen the likelihood of failures that might cause harm and take appropriate actions. Designer agrees that prior to using or distributing any applications that include TI products, Designer will thoroughly test such applications and the functionality of such TI products as used in such applications.

TI's provision of technical, application or other design advice, quality characterization, reliability data or other services or information, including, but not limited to, reference designs and materials relating to evaluation modules, (collectively, "TI Resources") are intended to assist designers who are developing applications that incorporate TI products; by downloading, accessing or using TI Resources in any way, Designer (individually or, if Designer is acting on behalf of a company, Designer's company) agrees to use any particular TI Resource solely for this purpose and subject to the terms of this Notice.

TI's provision of TI Resources does not expand or otherwise alter TI's applicable published warranties or warranty disclaimers for TI products, and no additional obligations or liabilities arise from TI providing such TI Resources. TI reserves the right to make corrections, enhancements, improvements and other changes to its TI Resources. TI has not conducted any testing other than that specifically described in the published documentation for a particular TI Resource.

Designer is authorized to use, copy and modify any individual TI Resource only in connection with the development of applications that include the TI product(s) identified in such TI Resource. NO OTHER LICENSE, EXPRESS OR IMPLIED, BY ESTOPPEL OR OTHERWISE TO ANY OTHER TI INTELLECTUAL PROPERTY RIGHT, AND NO LICENSE TO ANY TECHNOLOGY OR INTELLECTUAL PROPERTY RIGHT OF TI OR ANY THIRD PARTY IS GRANTED HEREIN, including but not limited to any patent right, copyright, mask work right, or other intellectual property right relating to any combination, machine, or process in which TI products or services are used. Information regarding or referencing third-party products or services does not constitute a license to use such products or services, or a warranty or endorsement thereof. Use of TI Resources may require a license from a third party under the patents or other intellectual property of the third party, or a license from TI under the patents or other intellectual property of TI.

TI RESOURCES ARE PROVIDED "AS IS" AND WITH ALL FAULTS. TI DISCLAIMS ALL OTHER WARRANTIES OR REPRESENTATIONS, EXPRESS OR IMPLIED, REGARDING RESOURCES OR USE THEREOF, INCLUDING BUT NOT LIMITED TO ACCURACY OR COMPLETENESS, TITLE, ANY EPIDEMIC FAILURE WARRANTY AND ANY IMPLIED WARRANTIES OF MERCHANTABILITY, FITNESS FOR A PARTICULAR PURPOSE, AND NON-INFRINGEMENT OF ANY THIRD PARTY INTELLECTUAL PROPERTY RIGHTS. TI SHALL NOT BE LIABLE FOR AND SHALL NOT DEFEND OR INDEMNIFY DESIGNER AGAINST ANY CLAIM, INCLUDING BUT NOT LIMITED TO ANY INFRINGEMENT CLAIM THAT RELATES TO OR IS BASED ON ANY COMBINATION OF PRODUCTS EVEN IF DESCRIBED IN TI RESOURCES OR OTHERWISE. IN NO EVENT SHALL TI BE LIABLE FOR ANY ACTUAL, DIRECT, SPECIAL, COLLATERAL, INDIRECT, PUNITIVE, INCIDENTAL, CONSEQUENTIAL OR EXEMPLARY DAMAGES IN CONNECTION WITH OR ARISING OUT OF TI RESOURCES OR USE THEREOF, AND REGARDLESS OF WHETHER TI HAS BEEN ADVISED OF THE POSSIBILITY OF SUCH DAMAGES.

Unless TI has explicitly designated an individual product as meeting the requirements of a particular industry standard (e.g., ISO/TS 16949 and ISO 26262), TI is not responsible for any failure to meet such industry standard requirements.

Where TI specifically promotes products as facilitating functional safety or as compliant with industry functional safety standards, such products are intended to help enable customers to design and create their own applications that meet applicable functional safety standards and requirements. Using products in an application does not by itself establish any safety features in the application. Designers must ensure compliance with safety-related requirements and standards applicable to their applications. Designer may not use any TI products in life-critical medical equipment unless authorized officers of the parties have executed a special contract specifically governing such use. Life-critical medical equipment is medical equipment where failure of such equipment would cause serious bodily injury or death (e.g., life support, pacemakers, defibrillators, heart pumps, neurostimulators, and implantables). Such equipment includes, without limitation, all medical devices identified by the U.S. Food and Drug Administration as Class III devices and equivalent classifications outside the U.S.

TI may expressly designate certain products as completing a particular qualification (e.g., Q100, Military Grade, or Enhanced Product). Designers agree that it has the necessary expertise to select the product with the appropriate qualification designation for their applications and that proper product selection is at Designers' own risk. Designers are solely responsible for compliance with all legal and regulatory requirements in connection with such selection.

Designer will fully indemnify TI and its representatives against any damages, costs, losses, and/or liabilities arising out of Designer's non-compliance with the terms and provisions of this Notice.

Looking for pricing, stock, or lifecycle information?

Click below to explore more details on WIN SOURCE:

 [View OPA569AIDWPRG4](#) on WIN SOURCE

 [Texas Instruments](#) Information

Optimize Your Supply Chain with WIN SOURCE Solutions

-  Global Sourcing Solution
-  Obsolete Management
-  Cost Control Management
-  Shortage Management
-  Alternative Solution
-  Excess Inventory Management