



THE DATASHEET OF STL6P3LLH6



P-channel 30 V, 0.024 Ω typ., 6 A STripFET™ H6 Power MOSFET in a PowerFLAT™ 3.3 x 3.3 package

Datasheet - production data

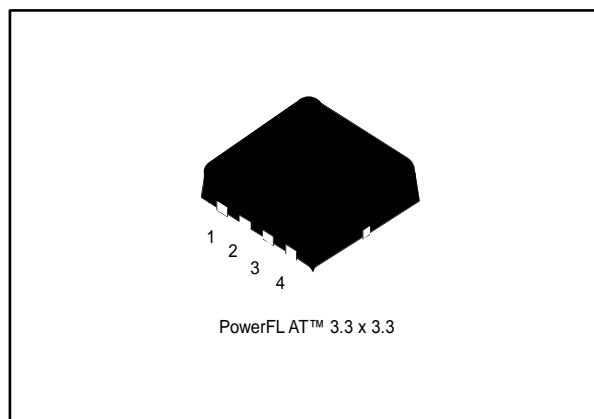
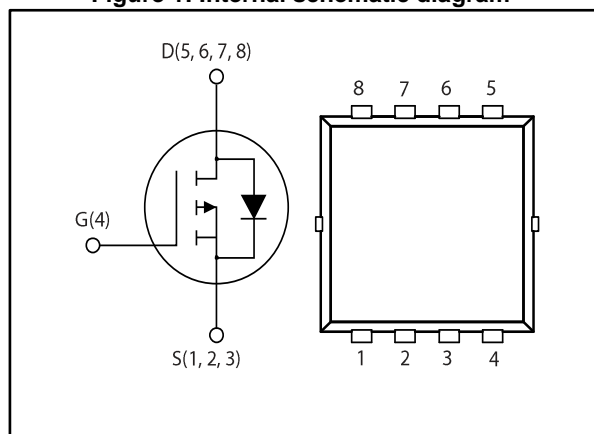

Figure 1: Internal schematic diagram



Features

Order code	V _{DS}	R _{DS(on)} max	I _D	P _{TOT}
STL6P3LLH6	30 V	0.03 Ω	6 A	2.9 W

- Very low on-resistance
- Very low gate charge
- High avalanche ruggedness
- Low gate drive power loss

Applications

- Switching applications

Description

This device is a P-channel Power MOSFET developed using the STripFET™ H6 technology, with a new trench gate structure. The resulting Power MOSFET exhibits very low R_{DS(on)} in all packages.

Table 1: Device summary

Order code	Marking	Package	Packaging
STL6P3LLH6	6P3L	PowerFLAT™ 3.3 x 3.3	Tape and reel

 For the P-channel Power MOSFETs the actual polarity of the voltages and the current must be reversed.

Contents

1 Electrical ratings 3

2 Electrical characteristics 4

 2.1 Electrical characteristics (curves) 6

3 Test circuits 8

4 Package mechanical data 9

 4.1 PowerFLAT™ 3.3 x 3.3 type C package information 9

 4.2 PowerFLAT™ 3.3 x 3.3 type F package information..... 11

5 Revision history 14



1 Electrical ratings

Table 2: Absolute maximum ratings

Symbol	Parameter	Value	Unit
V_{DS}	Drain-source voltage	30	V
V_{GS}	Gate-source voltage	± 20	V
$I_D^{(1)}$	Drain current (continuous) at $T_C = 25\text{ }^\circ\text{C}$	6	A
$I_D^{(1)}$	Drain current (continuous) at $T_C = 100\text{ }^\circ\text{C}$	3.8	A
$I_{DM}^{(1)(2)}$	Drain current (pulsed)	24	A
P_{TOT}	Total dissipation at $T_C = 25\text{ }^\circ\text{C}$	2.9	W
T_{stg}	Storage temperature	- 55 to 150	$^\circ\text{C}$
T_j	Max. operating junction temperature	150	$^\circ\text{C}$

Notes:

⁽¹⁾The value is rated according $R_{thj-pcb}$.

⁽²⁾Pulse width limited by safe operating area.

Table 3: Thermal data

Symbol	Parameter	Value	Unit
$R_{thj-case}$	Thermal resistance junction-case max	2.50	$^\circ\text{C/W}$
$R_{thj-pcb}^{(1)}$	Thermal resistance junction-pcb, single operation	42.8	$^\circ\text{C/W}$

Notes:

⁽¹⁾When mounted on FR-4 board of 1inch², 2oz Cu, t<10 sec.



For the P-channel Power MOSFETs the actual polarity of the voltages and the current must be reversed.

2 Electrical characteristics

($T_C = 25\text{ °C}$ unless otherwise specified)

Table 4: On /off states

Symbol	Parameter	Test conditions	Min.	Typ.	Max.	Unit
$V_{(BR)DSS}$	Drain-source breakdown voltage	$V_{GS} = 0, I_D = 250\ \mu\text{A}$	30			V
I_{DSS}	Zero gate voltage drain current	$V_{GS} = 0, V_{DS} = 30\ \text{V}$			1	μA
		$V_{GS} = 0, V_{DS} = 30\ \text{V}$ $T_C = 125\text{ °C}$			10	μA
I_{GSS}	Gate-body leakage current	$V_{DS} = 0, V_{GS} = \pm 20\ \text{V}$			± 100	nA
$V_{GS(th)}$	Gate threshold voltage	$V_{DS} = V_{GS}, I_D = 250\ \mu\text{A}$	1			V
$R_{DS(on)}$	Static drain-source on-resistance	$V_{GS} = 10\ \text{V}, I_D = 3\ \text{A}$		0.024	0.03	Ω
		$V_{GS} = 4.5\ \text{V}, I_D = 3\ \text{A}$		0.038	0.05	Ω

Table 5: Dynamic

Symbol	Parameter	Test conditions	Min.	Typ.	Max.	Unit
C_{iss}	Input capacitance	$V_{DS} = 25\ \text{V}$ $f = 1\ \text{MHz}$ $V_{GS} = 0$	-	1450	-	pF
C_{oss}	Output capacitance		-	178	-	pF
C_{rss}	Reverse transfer capacitance		-	120	-	pF
Q_g	Total gate charge	$V_{DD} = 24\ \text{V}, I_D = 6\ \text{A},$ $V_{GS} = 4.5\ \text{V}$ (see Figure 13: "Switching times test circuit for resistive load")	-	12	-	nC
Q_{gs}	Gate-source charge		-	4.4	-	nC
Q_{gd}	Gate-drain charge		-	5	-	nC

Table 6: Switching times

Symbol	Parameter	Test conditions	Min.	Typ.	Max.	Unit
$t_{d(on)}$	Turn-on delay time	$V_{DD} = 24\ \text{V}, I_D = 3\ \text{A}$ $R_G = 4.7\ \Omega$ $V_{GS} = 10\ \text{V}$	-	15	-	ns
t_r	Rise time		-	15	-	ns
$t_{d(off)}$	Turn-off delay time		-	24	-	ns
t_f	Fall time		-	21	-	ns



For the P-channel Power MOSFETs the actual polarity of the voltages and the current must be reversed.

Table 7: Source drain diode

Symbol	Parameter	Test conditions	Min.	Typ.	Max.	Unit
V_{SD}	Forward on voltage	$I_{SD} = 6 \text{ A}$, $V_{GS} = 0$	-		1.1	V
t_{rr}	Reverse recovery time	$I_{SD} = 6 \text{ A}$, $di/dt = 100 \text{ A}/\mu\text{s}$ $V_{DD} = 16 \text{ V}$, $T_j = 150 \text{ }^\circ\text{C}$	-	15		ns
Q_{rr}	Reverse recovery charge		-	6.5		nC
I_{RRM}	Reverse recovery current		-	0.9		A

2.1 Electrical characteristics (curves)

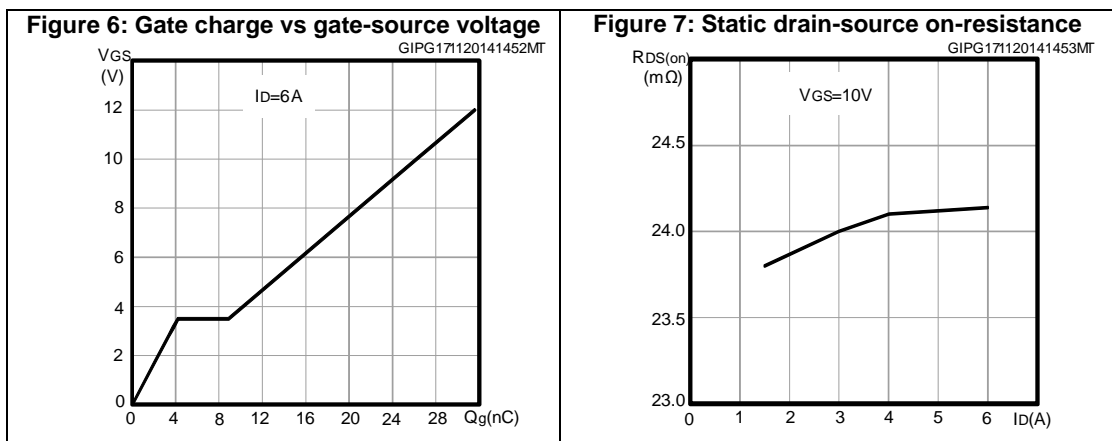
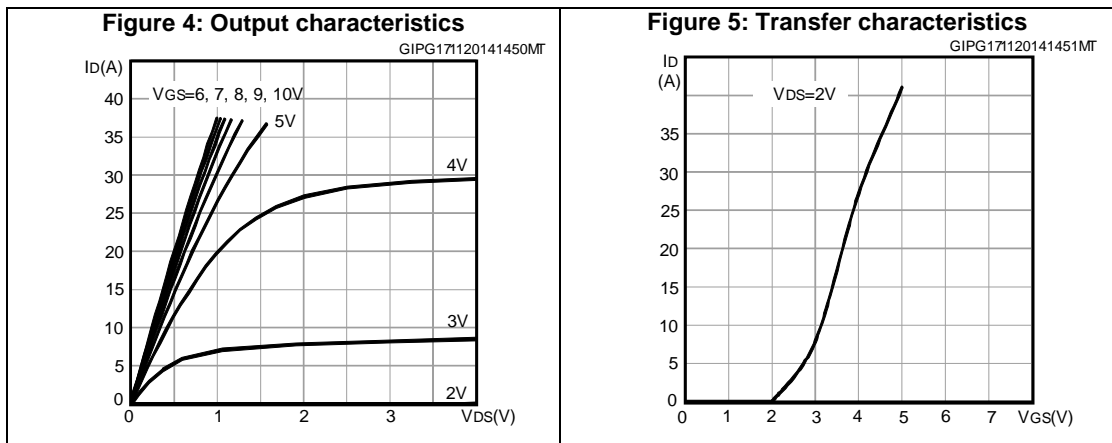
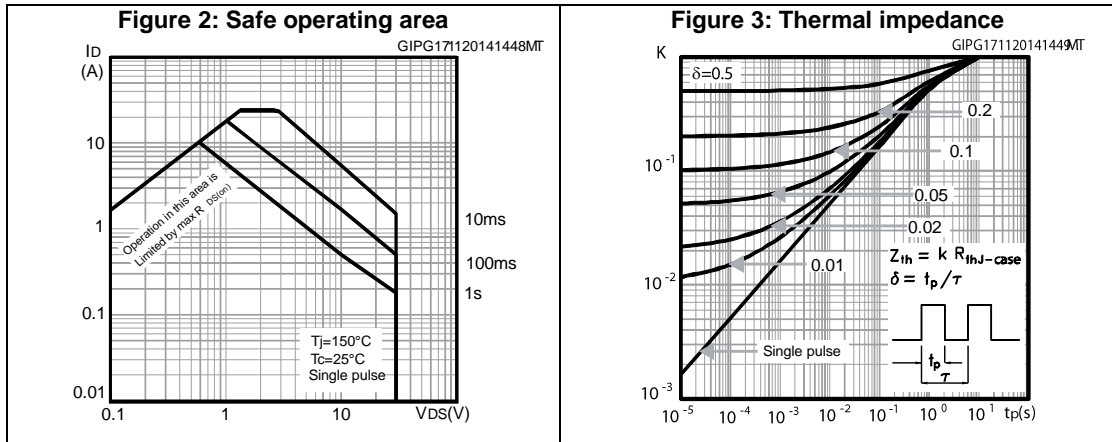

Figure 8: Capacitance variations

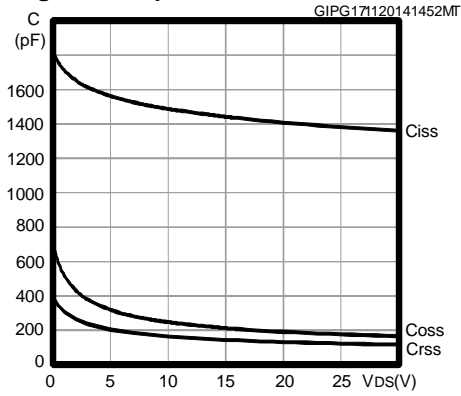

Figure 9: Normalized gate threshold voltage vs temperature

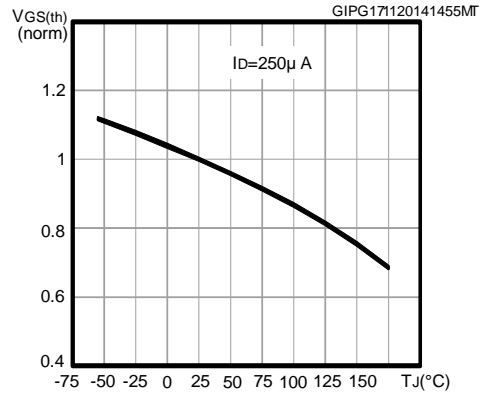

Figure 10: Normalized on-resistance vs temperature

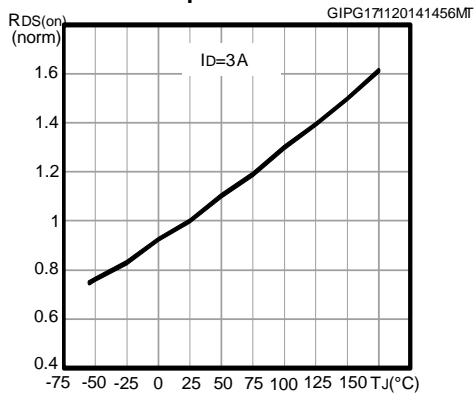

Figure 11: Normalized VDS vs temperature

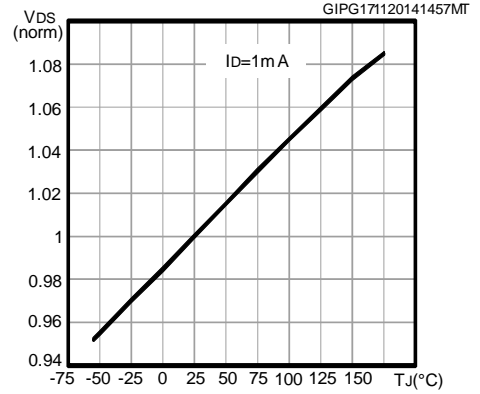
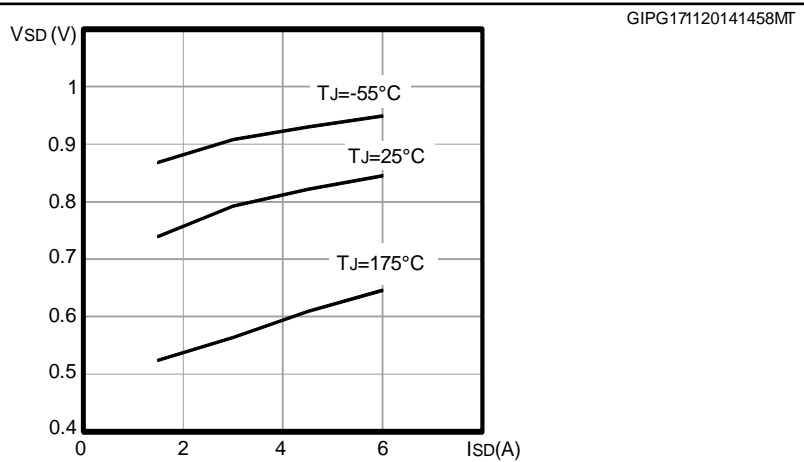

Figure 12: Source-drain diode forward characteristics



3 Test circuits

Figure 13: Switching times test circuit for resistive load

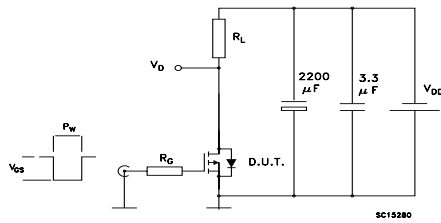

Figure 14: Gate charge test circuit

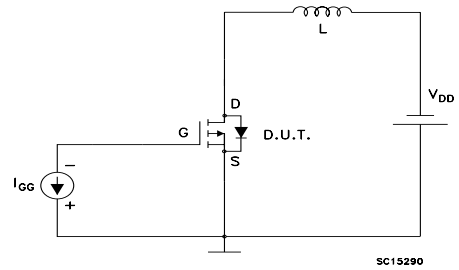
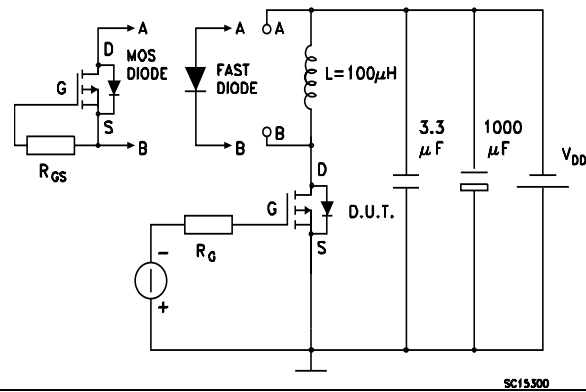

Figure 15: Test circuit for inductive load switching and diode recovery times



4 Package mechanical data

In order to meet environmental requirements, ST offers these devices in different grades of ECOPACK® packages, depending on their level of environmental compliance. ECOPACK® specifications, grade definitions and product status are available at: www.st.com. ECOPACK® is an ST trademark.

4.1 PowerFLAT™ 3.3 x 3.3 type C mechanical data

Figure 16: PowerFLAT™ 3.3 x 3.3 type C drawing

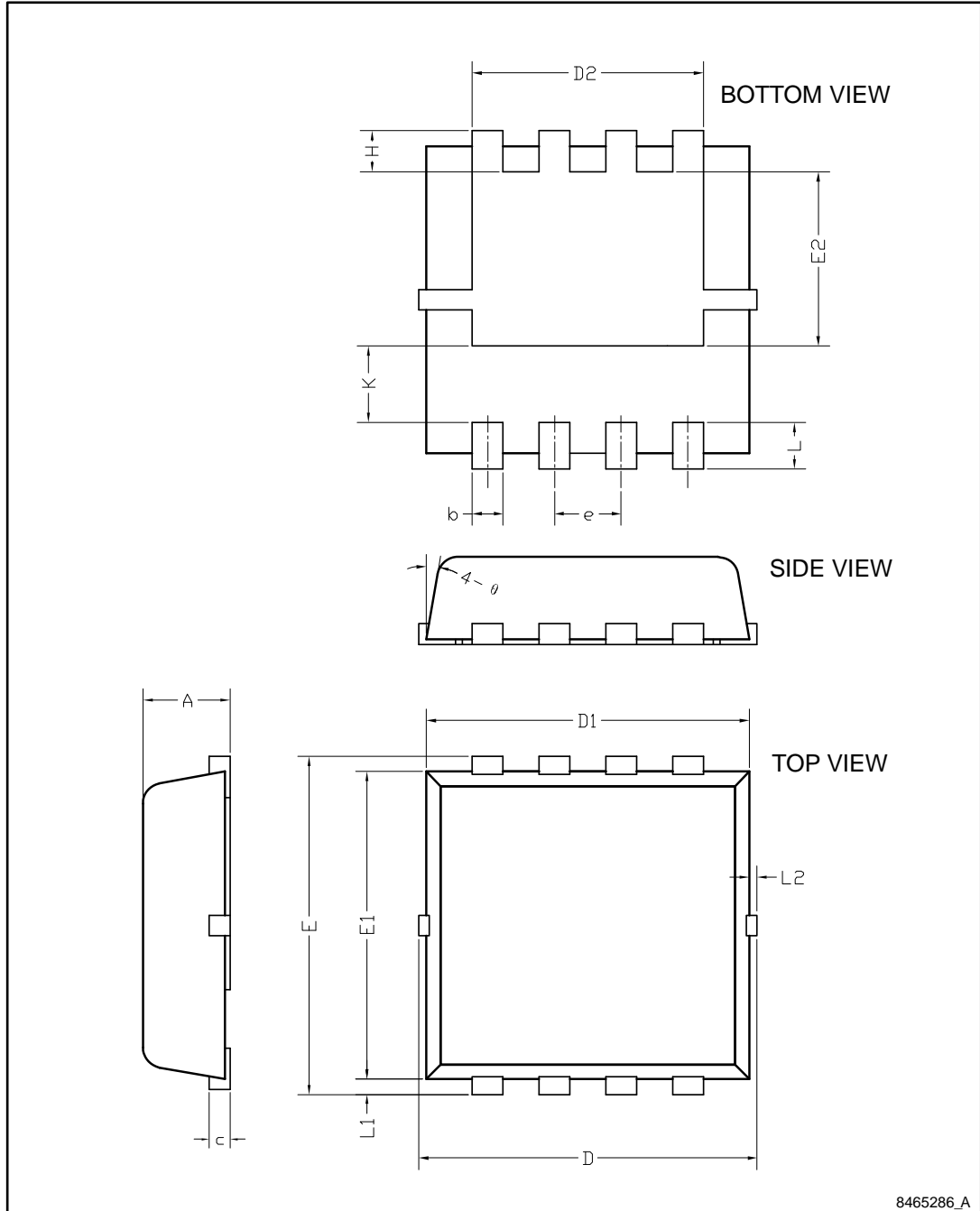
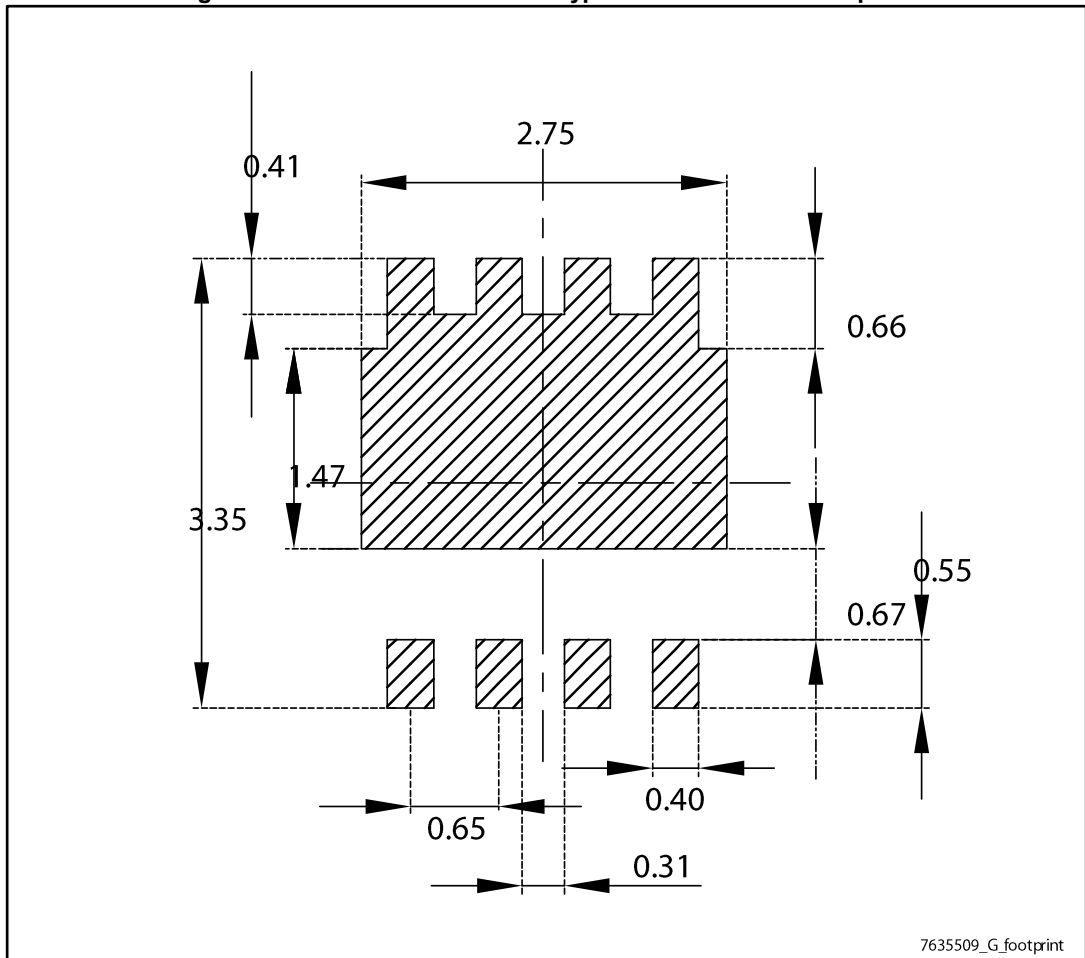

Table 8: PowerFLAT™ 3.3 x 3.3 type C mechanical data

Dim.	mm		
	Min.	Typ.	Max.
A	0.80	0.90	1.00
A1	0		0.05
A3		0.20	
b	0.23		0.38
D	3.20	3.30	3.40
D2	2.50		2.75
E	3.20	3.30	3.40
E2	1.25		1.50
e		0.65	
L	0.30		0.50

Figure 17: PowerFLAT™ 3.3 x 3.3 type C recommended footprint



4.2 PowerFLAT™ 3.3 x 3.3 type F mechanical data

Figure 18: PowerFLAT™ 3.3 x 3.3 type F drawing

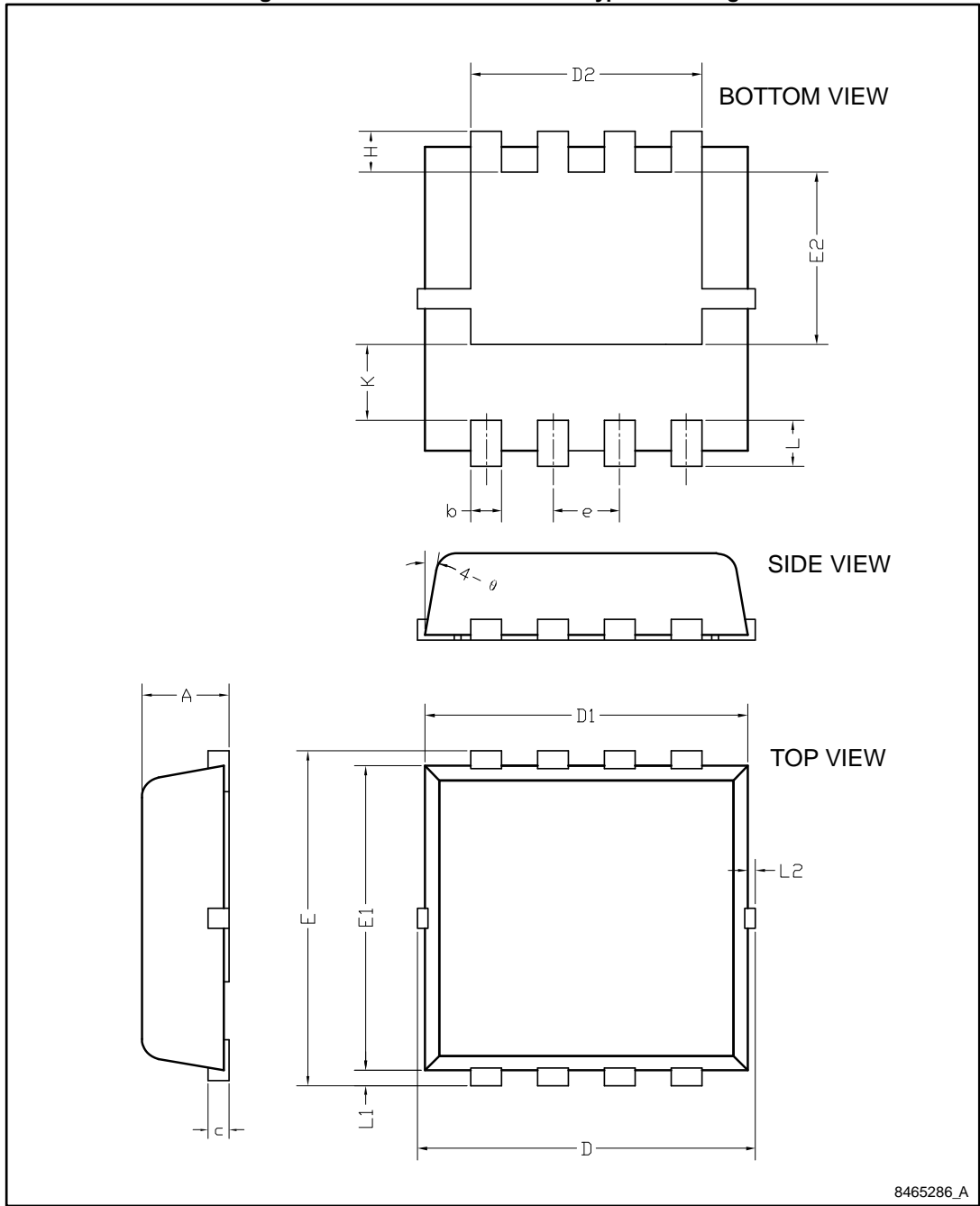
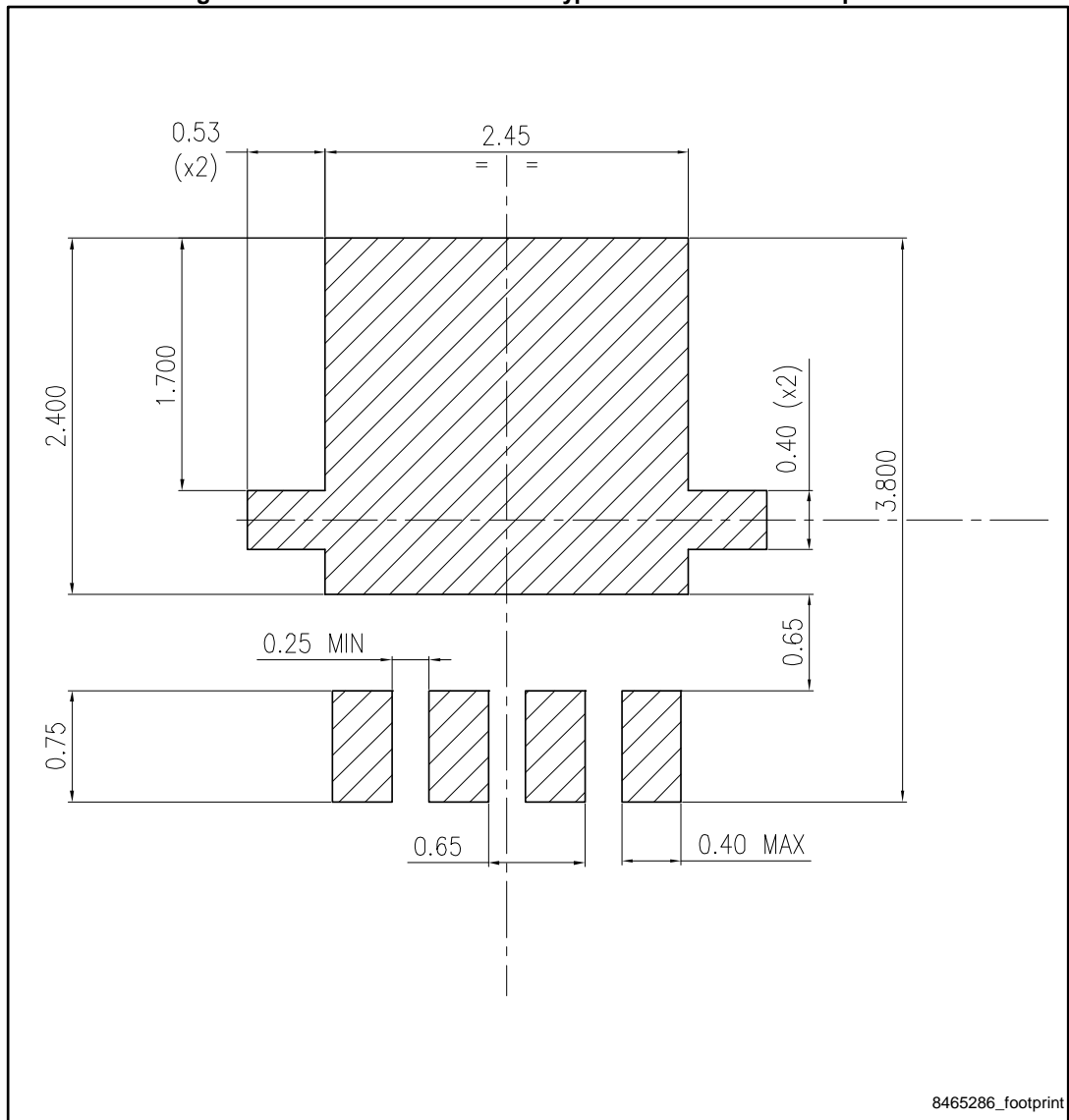

Table 9: PowerFLAT™ 3.3 x 3.3 type F mechanical data

Dim.	mm		
	Min.	Typ.	Max.
A	0.70	0.80	0.90
b	0.25	0.30	0.39
c	0.14	0.15	0.20
D	3.10	3.30	3.50
D1	3.05	3.15	3.25
D2	2.15	2.25	2.35
e	0.55	0.65	0.75
E	3.10	3.30	3.50
E1	2.90	3.00	3.10
E2	1.60	1.70	1.80
H	0.25	0.40	0.55
K	0.65	0.75	0.85
L	0.30	0.45	0.60
L1	0.05	0.15	0.25
L2			0.15
J	8°	10°	12°

Figure 19: PowerFLAT™ 3.3 x 3.3 type F recommended footprint



5 Revision history

Table 10: Document revision history

Date	Revision	Changes
04-Mar-2013	1	First release.
28-Nov-2013	2	<ul style="list-style-type: none"> Modified: P_{TOT} value, silhouette and not found in cover page Modified: V_{GS} and P_{TOT} values in not found Modified: $R_{thj-pcb}$ value and note ⁽¹⁾ in Table 3: "Thermal data" Modified: I_{GSS} test conditions value Modified: Q_g in Table 5: "Dynamic" Added: Table 9: "PowerFLAT™ 3.3 x 3.3 type F mechanical data", Figure 18: "PowerFLAT™ 3.3 x 3.3 type F drawing" and Figure 19: "PowerFLAT™ 3.3 x 3.3 type F recommended footprint" Minor text changes
26-Nov-2014	3	<p>Updated Figure 1: "Internal schematic diagram".</p> <p>Added Section 4.1: "PowerFLAT™ 3.3 x 3.3 type C package information" and Section 4.2: "PowerFLAT™ 3.3 x 3.3 type F package information".</p> <p>Minor text changes.</p>

IMPORTANT NOTICE – PLEASE READ CAREFULLY

STMicroelectronics NV and its subsidiaries ("ST") reserve the right to make changes, corrections, enhancements, modifications, and improvements to ST products and/or to this document at any time without notice. Purchasers should obtain the latest relevant information on ST products before placing orders. ST products are sold pursuant to ST's terms and conditions of sale in place at the time of order acknowledgement.

Purchasers are solely responsible for the choice, selection, and use of ST products and ST assumes no liability for application assistance or the design of Purchasers' products.

No license, express or implied, to any intellectual property right is granted by ST herein.

Resale of ST products with provisions different from the information set forth herein shall void any warranty granted by ST for such product.



ST and the ST logo are trademarks of ST. All other product or service names are the property of their respective owners.

Information in this document supersedes and replaces information previously supplied in any prior versions of this document.

© 2014 STMicroelectronics – All rights reserved

Looking for pricing, stock, or lifecycle information?

Click below to explore more details on WIN SOURCE:

-  [View STL6P3LLH6 on WIN SOURCE](#)
-  [STMicroelectronics Information](#)

Optimize Your Supply Chain with WIN SOURCE Solutions

-  Global Sourcing Solution
-  Obsolete Management
-  Cost Control Management
-  Shortage Management
-  Alternative Solution
-  Excess Inventory Management