



**THE DATASHEET OF  
IRFHM8235TRPBF**



$V_{DSS}$	<b>25</b>	<b>V</b>
$V_{GS\ max}$	<b>±20</b>	<b>V</b>
$R_{DS(on)\ max}$ (@ $V_{GS} = 10V$ )	<b>7.7</b>	<b>mΩ</b>
(@ $V_{GS} = 4.5V$ )	<b>13.4</b>	
$Q_g$ (typical)	<b>7.7</b>	<b>nC</b>
$I_D$ (@ $T_C(Bottom) = 25^\circ C$ )	<b>25</b>	<b>A</b>

HEXFET® Power MOSFET

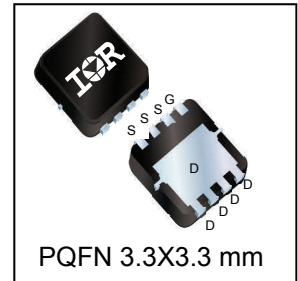
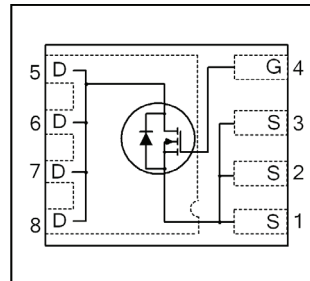
**Applications**

- Control MOSFET for synchronous buck converter

**Features**

Low Thermal Resistance to PCB (<4.1°C/W)
Low Profile (<1.05mm)
Industry-Standard Pin out
Compatible with Existing Surface Mount Techniques
RoHS Compliant, Halogen-Free
MSL1, Consumer Qualification

 results in  
⇒

**Benefits**

Enable better Thermal Dissipation
Increased Power Density
Multi-Vendor Compatibility
Easier Manufacturing
Environmentally Friendlier
Increased Reliability

Base part number	Package Type	Standard Pack		Orderable Part Number
		Form	Quantity	
IRFHM8235PbF	PQFN 3.3 mm x 3.3 mm	Tape and Reel	4000	IRFHM8235TRPbF

**Absolute Maximum Ratings**

	Parameter	Max.	Units
$V_{GS}$	Gate-to-Source Voltage	± 20	V
$I_D @ T_A = 25^\circ C$	Continuous Drain Current, $V_{GS} @ 10V$	16	A
$I_D @ T_A = 70^\circ C$	Continuous Drain Current, $V_{GS} @ 10V$	13	
$I_D @ T_C(Bottom) = 25^\circ C$	Continuous Drain Current, $V_{GS} @ 10V$	50 <sup>⑥⑦</sup>	
$I_D @ T_C(Bottom) = 100^\circ C$	Continuous Drain Current, $V_{GS} @ 10V$	32 <sup>⑥⑦</sup>	
$I_D @ T_C = 25^\circ C$	Continuous Drain Current, $V_{GS} @ 10V$ (Source Bonding Technology Limited)	25 <sup>⑦</sup>	
$I_{DM}$	Pulsed Drain Current <sup>①</sup>	240 <sup>⑧</sup>	
$P_D @ T_A = 25^\circ C$	Power Dissipation <sup>⑤</sup>	3.0	W
$P_D @ T_C(Bottom) = 25^\circ C$	Power Dissipation <sup>⑤</sup>	30	
	Linear Derating Factor <sup>⑤</sup>	0.024	W/°C
$T_J$ $T_{STG}$	Operating Junction and Storage Temperature Range	-55 to + 150	°C

 Notes <sup>①</sup> through <sup>⑧</sup> are on page 10

**Static @ T<sub>J</sub> = 25°C (unless otherwise specified)**

	Parameter	Min.	Typ.	Max.	Units	Conditions					
BV <sub>DSS</sub>	Drain-to-Source Breakdown Voltage	25	—	—	V	V <sub>GS</sub> = 0V, I <sub>D</sub> = 250μA					
ΔBV <sub>DSS</sub> /ΔT <sub>J</sub>	Breakdown Voltage Temp. Coefficient	—	19	—	mV/°C	Reference to 25°C, I <sub>D</sub> = 1.0mA					
R <sub>DS(on)</sub>	Static Drain-to-Source On-Resistance	—	6.2	7.7	mΩ	V <sub>GS</sub> = 10V, I <sub>D</sub> = 20A ③					
		—	10.3	13.4		V <sub>GS</sub> = 4.5V, I <sub>D</sub> = 16A ③					
V <sub>GS(th)</sub>	Gate Threshold Voltage	1.35	1.8	2.35	V	V <sub>DS</sub> = V <sub>GS</sub> , I <sub>D</sub> = 25μA					
ΔV <sub>GS(th)</sub>	Gate Threshold Voltage Coefficient	—	-5.9	—	mV/°C						
I <sub>DSS</sub>	Drain-to-Source Leakage Current	—	—	1.0	μA	V <sub>DS</sub> = 20V, V <sub>GS</sub> = 0V					
		—	—	150		V <sub>DS</sub> = 20V, V <sub>GS</sub> = 0V, T <sub>J</sub> = 125°C					
I <sub>GSS</sub>	Gate-to-Source Forward Leakage	—	—	100	nA	V <sub>GS</sub> = 20V					
	Gate-to-Source Reverse Leakage	—	—	-100		V <sub>GS</sub> = -20V					
g <sub>fs</sub>	Forward Transconductance	43	—	—	S	V <sub>DS</sub> = 10V, I <sub>D</sub> = 20A					
Q <sub>g</sub>	Total Gate Charge	—	16	—	nC	V <sub>GS</sub> = 10V, V <sub>DS</sub> = 13V, I <sub>D</sub> = 20A					
Q <sub>g</sub>	Total Gate Charge	—	7.7	12	nC	V <sub>DS</sub> = 13V V <sub>GS</sub> = 4.5V I <sub>D</sub> = 20A					
							Q <sub>gs1</sub>	Pre-V <sub>th</sub> Gate-to-Source Charge	—	1.9	—
							Q <sub>gs2</sub>	Post-V <sub>th</sub> Gate-to-Source Charge	—	1.3	—
							Q <sub>gd</sub>	Gate-to-Drain Charge	—	2.7	—
							Q <sub>godr</sub>	Gate Charge Overdrive	—	1.5	—
Q <sub>sw</sub>	Switch Charge (Q <sub>gs2</sub> + Q <sub>gd</sub> )	—	4.0	—							
Q <sub>oss</sub>	Output Charge	—	6.4	—	nC	V <sub>DS</sub> = 16V, V <sub>GS</sub> = 0V					
R <sub>G</sub>	Gate Resistance	—	1.6	—	Ω						
t <sub>d(on)</sub>	Turn-On Delay Time	—	7.9	—	ns	V <sub>DD</sub> = 13V, V <sub>GS</sub> = 4.5V I <sub>D</sub> = 20A R <sub>G</sub> = 1.8Ω					
	t <sub>r</sub>	Rise Time	—	16			—				
	t <sub>d(off)</sub>	Turn-Off Delay Time	—	7.5			—				
	t <sub>f</sub>	Fall Time	—	5.2			—				
C <sub>iss</sub>	Input Capacitance	—	1040	—	pF	V <sub>GS</sub> = 0V V <sub>DS</sub> = 10V f = 1.0MHz					
C <sub>oss</sub>	Output Capacitance	—	300	—							
C <sub>rss</sub>	Reverse Transfer Capacitance	—	120	—							

**Avalanche Characteristics**

	Parameter	Typ.	Max.	Units
E <sub>AS</sub>	Single Pulse Avalanche Energy ②	—	41	mJ

**Diode Characteristics**

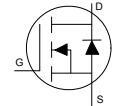
	Parameter	Min.	Typ.	Max.	Units	Conditions
I <sub>S</sub>	Continuous Source Current (Body Diode)	—	—	25⑦	A	MOSFET symbol showing the integral reverse p-n junction diode. 
I <sub>SM</sub>	Pulsed Source Current (Body Diode) ①	—	—	240⑧		
V <sub>SD</sub>	Diode Forward Voltage	—	—	1.0	V	T <sub>J</sub> = 25°C, I <sub>S</sub> = 20A, V <sub>GS</sub> = 0V ③
t <sub>rr</sub>	Reverse Recovery Time	—	10	15	ns	T <sub>J</sub> = 25°C, I <sub>F</sub> = 20A, V <sub>DD</sub> = 13V
Q <sub>rr</sub>	Reverse Recovery Charge	—	4.9	7.4	nC	di/dt = 300A/μs ③

**Thermal Resistance**

	Parameter	Typ.	Max.	Units
R <sub>θJC</sub> (Bottom)	Junction-to-Case ④	—	4.1	°C/W
R <sub>θJC</sub> (Top)	Junction-to-Case ④	—	42	
R <sub>θJA</sub>	Junction-to-Ambient ⑤	—	42	
R <sub>θJA</sub> (<10s)	Junction-to-Ambient ⑤	—	28	

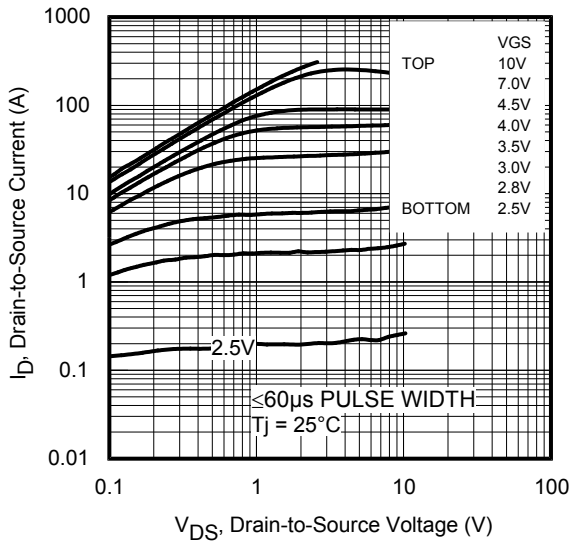
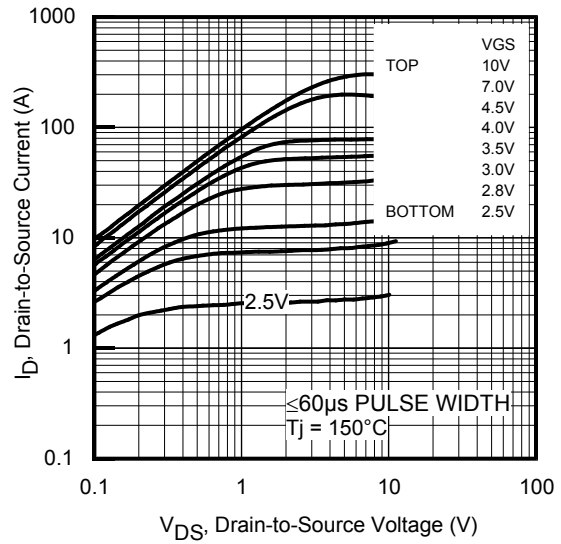
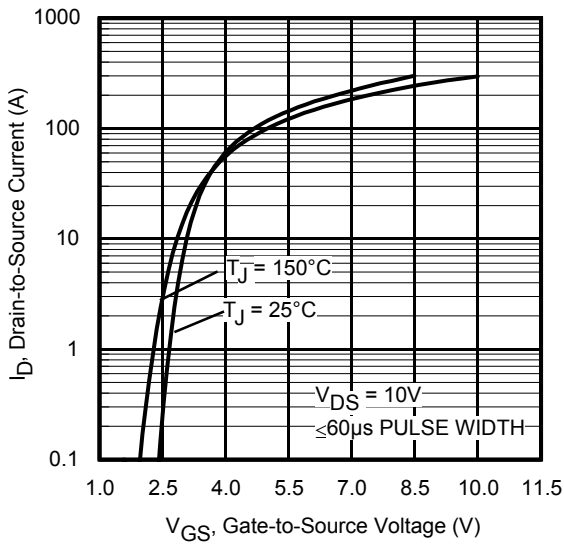
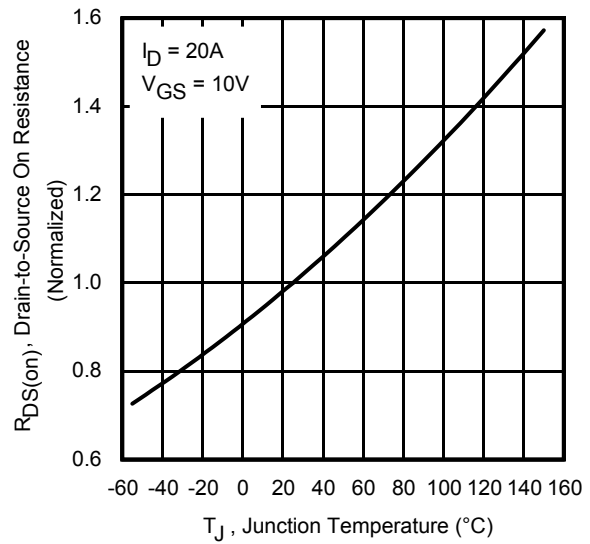
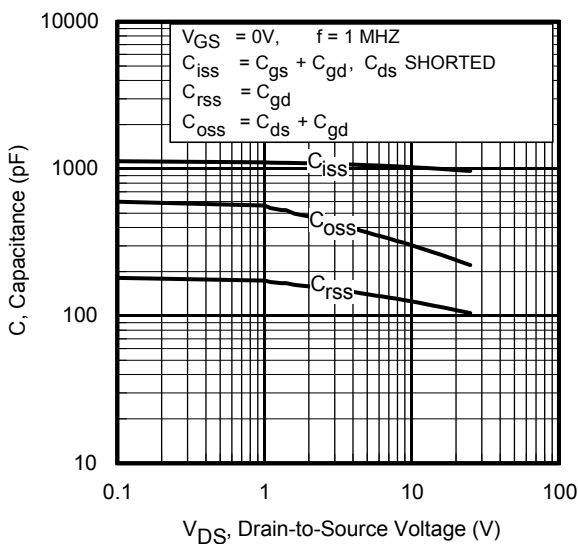
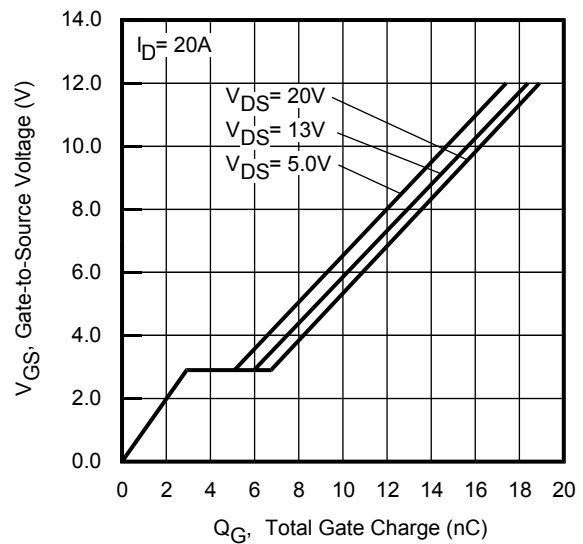
**Fig 1. Typical Output Characteristics**

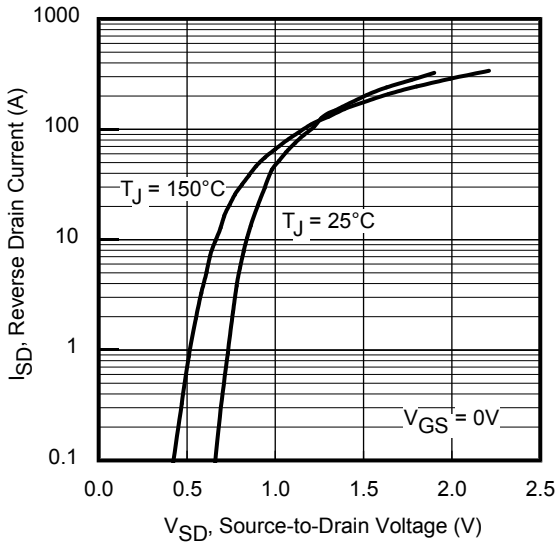
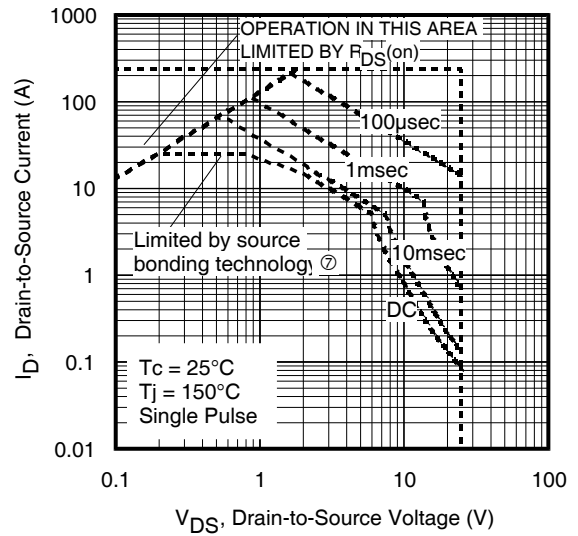
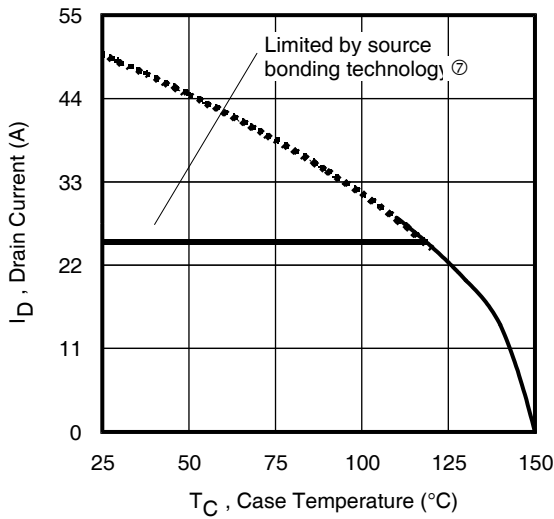
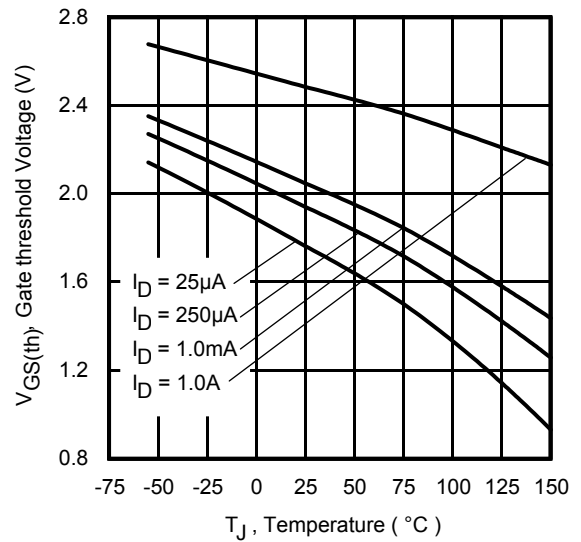
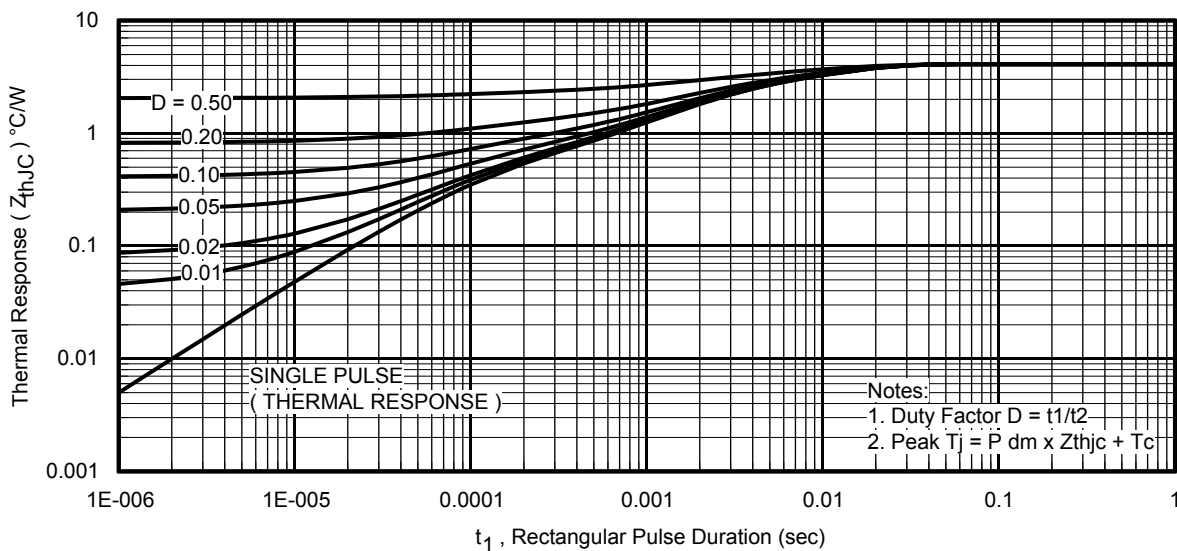
**Fig 2. Typical Output Characteristics**

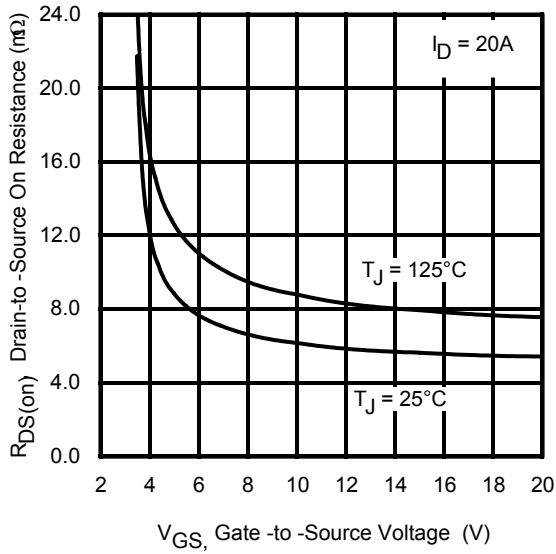
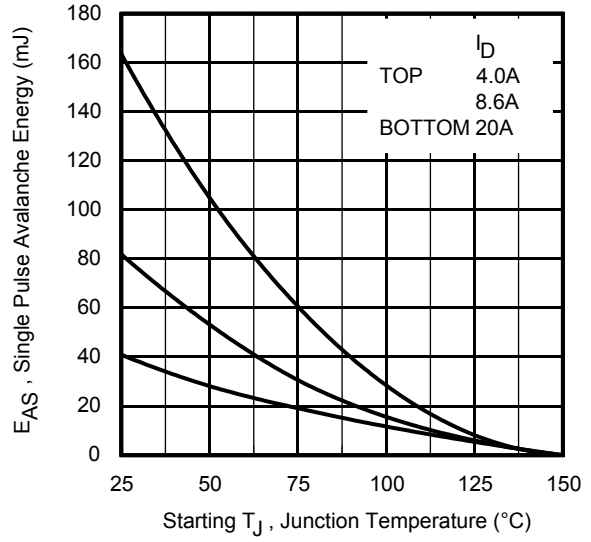
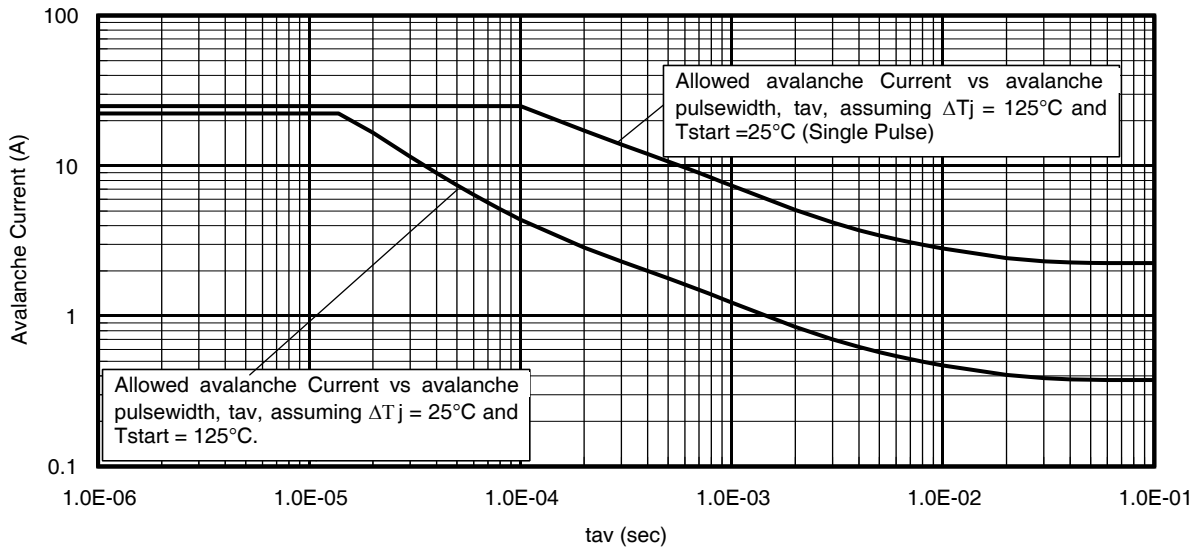
**Fig 3. Typical Transfer Characteristics**

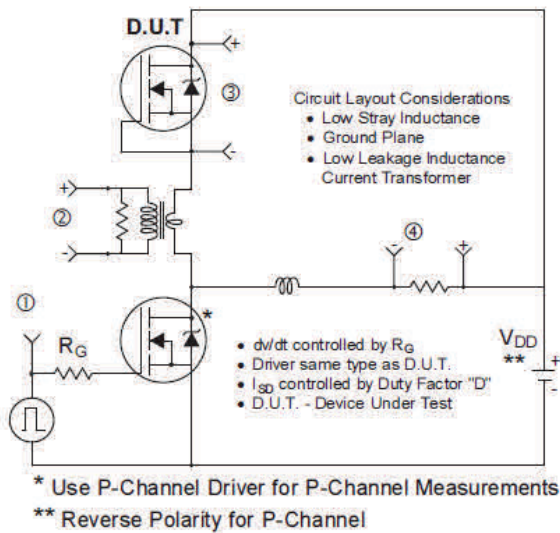
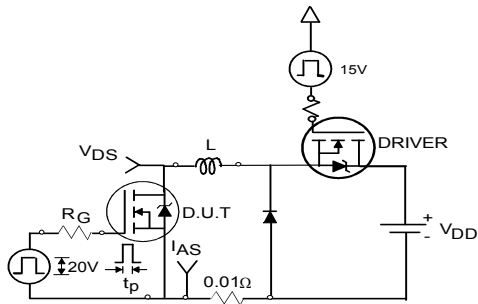
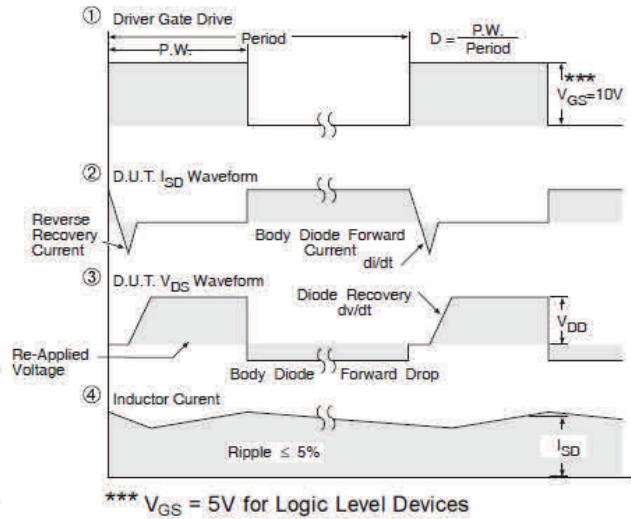
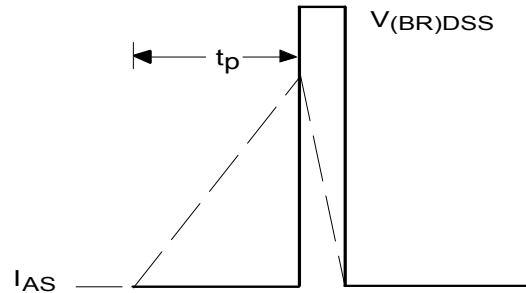
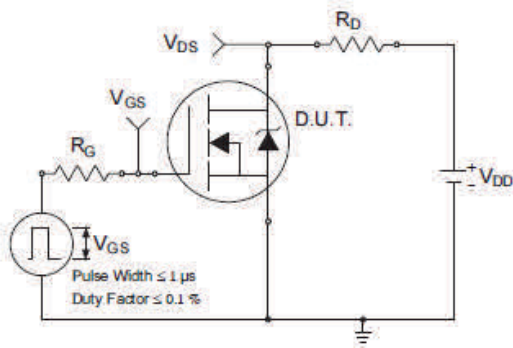
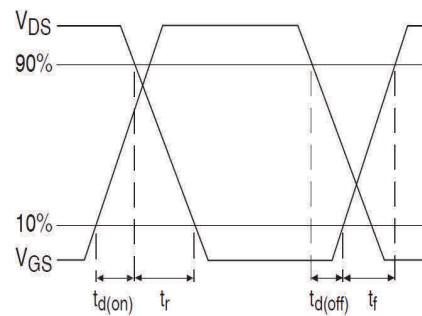
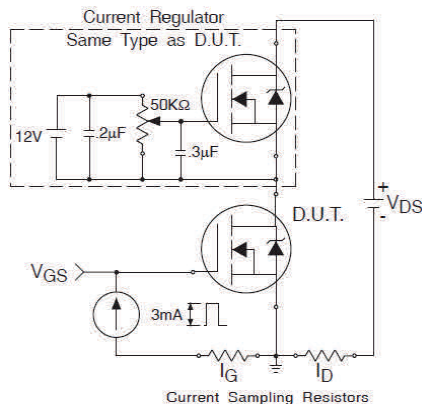
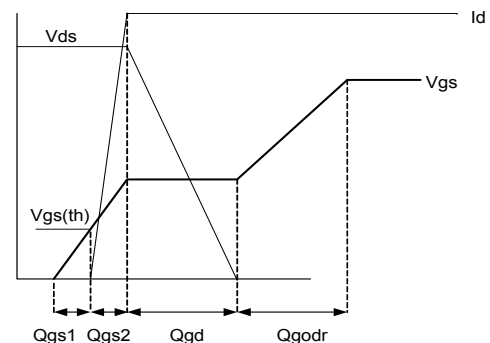
**Fig 4. Normalized On-Resistance vs. Temperature**

**Fig 5. Typical Capacitance vs. Drain-to-Source Voltage**

**Fig 6. Typical Gate Charge vs. Gate-to-Source Voltage**

**Fig 7.** Typical Source-Drain Diode Forward Voltage

**Fig 8.** Maximum Safe Operating Area

**Fig 9.** Maximum Drain Current vs. Case Temperature

**Fig 10.** Threshold Voltage Vs. Temperature

**Fig 11.** Maximum Effective Transient Thermal Impedance, Junction-to-Case

**Fig 12.** On-Resistance vs. Gate Voltage

**Fig 13.** Maximum Avalanche Energy vs. Drain Current

**Fig 14.** Single avalanche event: pulse current vs. pulse width

**Fig 15. Peak Diode Recovery dv/dt Test Circuit for N-Channel HEXFET® Power MOSFETs**

**Fig 16a. Unclamped Inductive Test Circuit**

**Fig 16b. Unclamped Inductive Waveforms**

**Fig 17a. Switching Time Test Circuit**

**Fig 17b. Switching Time Waveforms**

**Fig 18a. Gate Charge Test Circuit**

**Fig 18b. Gate Charge Waveform**

### Placement and Layout Guidelines

The typical application topology for this product is the synchronous buck converter. These converters operate at high frequencies (typically around 400 kHz). During turn-on and turn-off switching cycles, the high di/dt currents circulating in the parasitic elements of the circuit induce high voltage ringing which may exceed the device rating and lead to undesirable effects. One of the major contributors to the increase in parasitics is the PCB power circuit inductance.

This section introduces a simple guideline that mitigates the effect of these parasitics on the performance of the circuit and provides reliable operation of the devices.

To reduce high frequency switching noise and the effects of Electromagnetic Interference (EMI) when the control MOSFET (Q1) is turned on, the layout shown in Figure 19 is recommended. The input bypass capacitors, control MOSFET and output capacitors are placed in a tight loop to minimize parasitic inductance which in turn lowers the amplitude of the switch node ringing, and minimizes exposure of the MOSFETs to repetitive avalanche conditions.

When the synchronous MOSFET (Q2) is turned on, high average DC current flows through the path indicated in Figure 19. Therefore, the Q2 turn-on path should be laid out with a tight loop and wide traces at both ends of the inductor to minimize loop resistance.

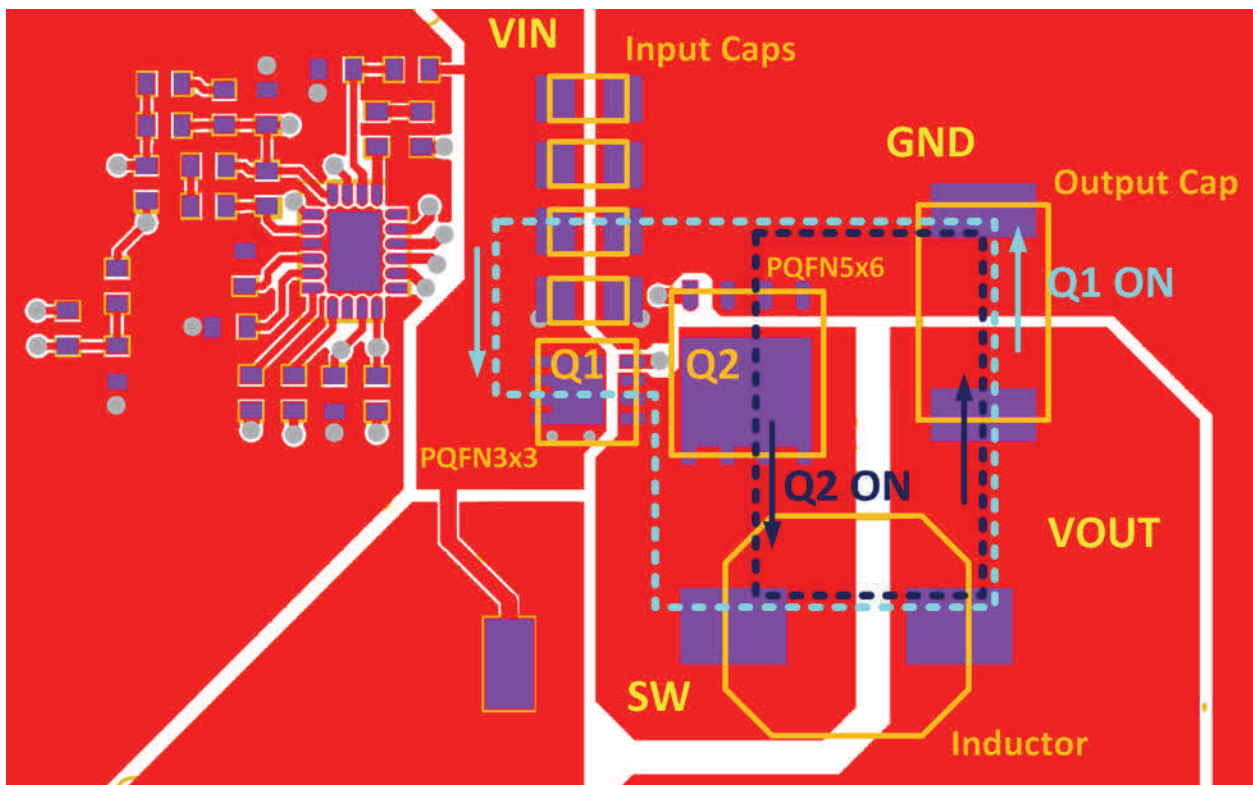

## PQFN 3.3 x 3.3 Outline "C" Package Details

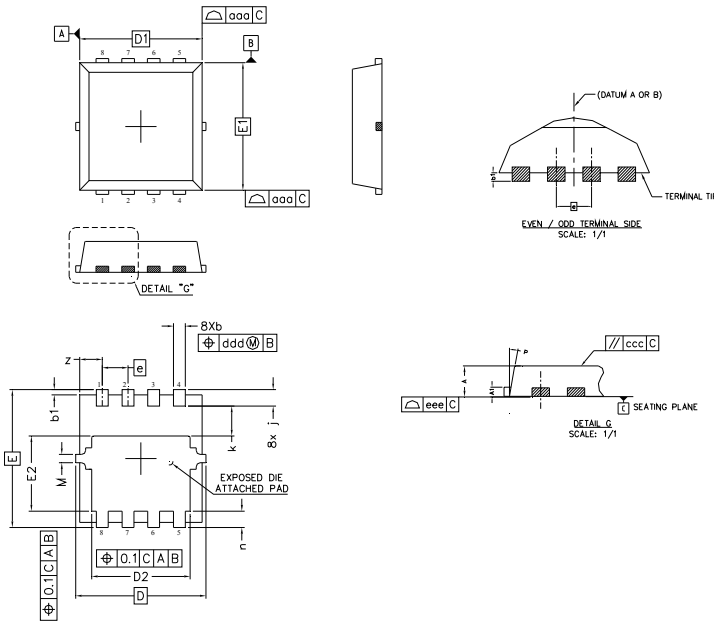

DIM	MILLIMETERS		INCHES	
	MIN	MAX	MIN	MAX
A	0.70	0.80	.0276	.0315
A1	0.10	0.25	.0039	.0098
b	0.25	0.35	.0098	.0138
b1	0.05	0.15	.0020	.0059
D	3.20	3.40	.1260	.1339
D1	3.00	3.20	.1181	.1260
D2	2.39	2.59	.0941	.1020
E	3.25	3.45	.1280	.1358
E1	3.00	3.20	.1181	.1260
E2	1.78	1.98	.0701	.0780
e	0.65 BSC		.0255 BSC	
j	0.30	0.50	.0118	.0197
k	0.59	0.79	.0232	.0311
n	0.30	0.50	.0118	.0197
M	0.03	0.23	.0012	.0091
P	10°	12°	10°	12°
z	0.50	0.70	.0197	.0276

## PQFN 3.3 x 3.3 Outline "G" Package Details

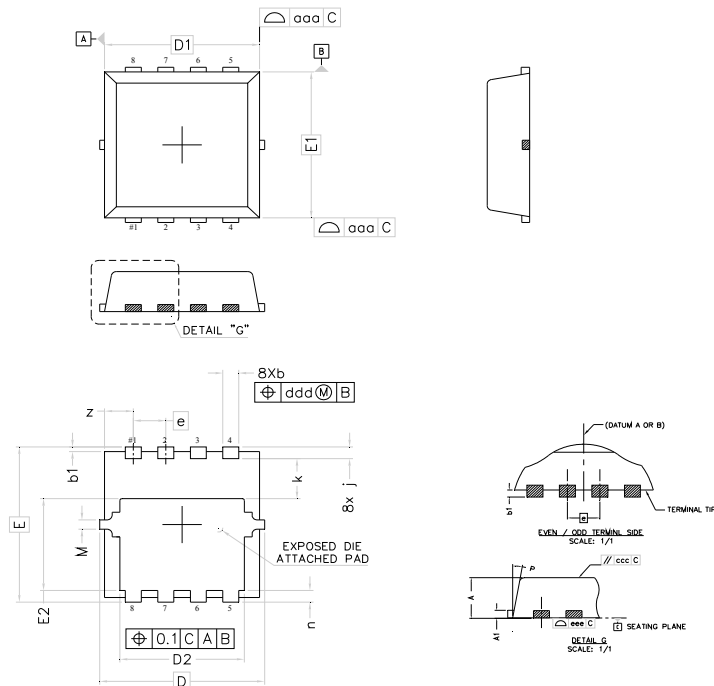

DIM	MILLIMETERS		INCHES	
	MIN	MAX	MIN	MAX
A	0.80	0.90	.0315	.0354
A1	0.12	0.22	.0047	.0086
b	0.22	0.42	.0087	.0165
b1	0.05	0.15	.0020	.0059
D	3.30 BSC		.1299 BSC	
D1	3.10 BSC		.1220 BSC	
D2	2.29	2.69	.0902	.1059
E	3.30 BSC		.1299 BSC	
E1	3.10 BSC		.1220 BSC	
E2	1.85	2.05	.0728	.0807
e	0.65 BSC		.0255 BSC	
j	0.15	0.35	.0059	.0137
k	0.75	0.95	.0295	.0374
n	0.15	0.35	.0059	.0137
M	NOM.	0.20	NOM.	.0078
P	9°	11°	9°	11°

For more information on board mounting, including footprint and stencil recommendation, please refer to application note AN-1136: <http://www.irf.com/technical-info/appnotes/an-1136.pdf>

For more information on package inspection techniques, please refer to application note AN-1154: <http://www.irf.com/technical-info/appnotes/an-1154.pdf>

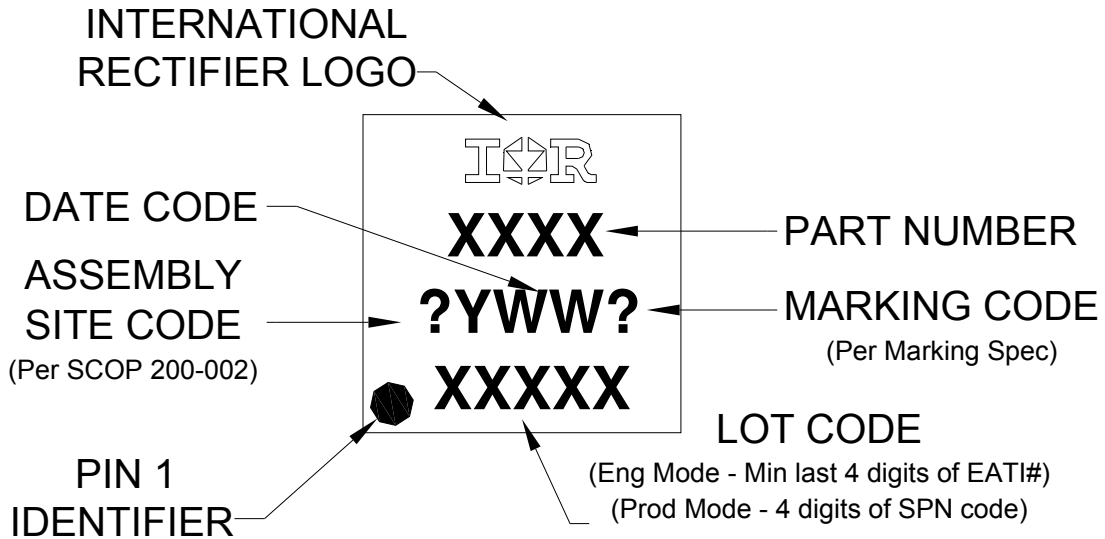
**PQFN 3.3mm x 3.3mm Outline Part Marking**

Note: For the most current drawing please refer to IR website at <http://www.irf.com/package/>

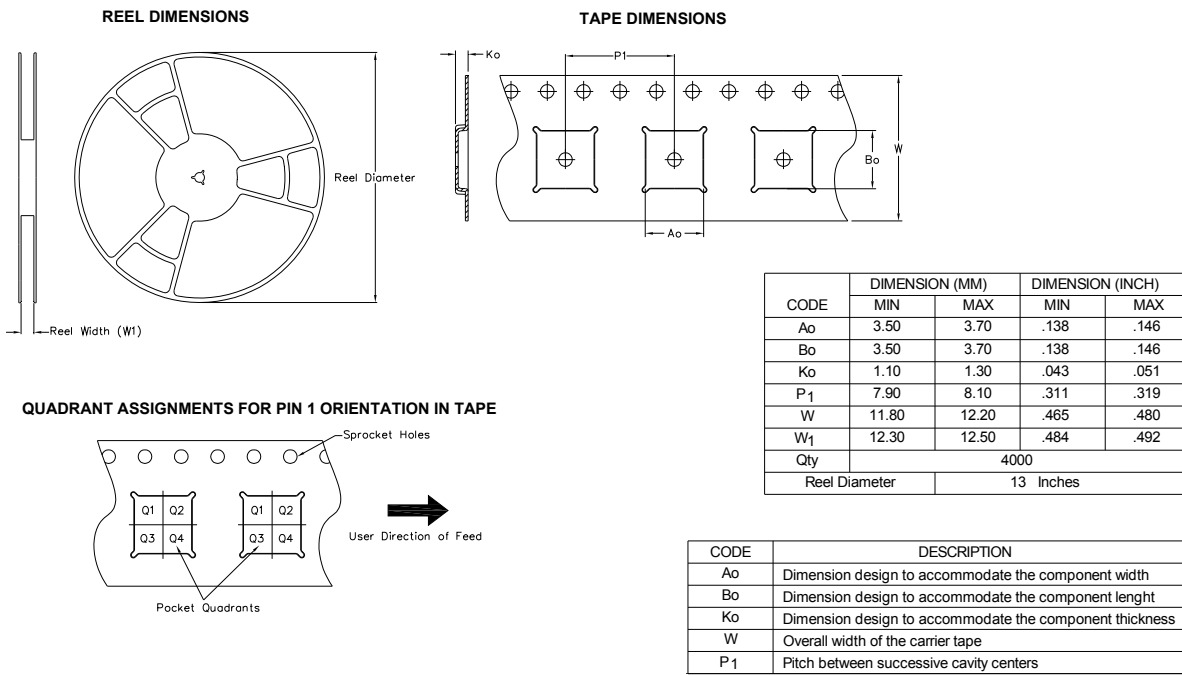
**PQFN 3.3mm x 3.3mm Outline Tape and Reel**

Note: For the most current drawing please refer to IR website at <http://www.irf.com/package/>

**Qualification Information†**

<b>Qualification Level</b>	Consumer <sup>††</sup> (per JEDEC JESD47F guidelines)	
<b>Moisture Sensitivity Level</b>	PQFN 3.3mm x 3.3mm	MSL1 (per JEDEC J-STD-020D <sup>†††</sup> )
<b>RoHS Compliant</b>	Yes	

† Qualification standards can be found at International Rectifier's web site: <http://www.irf.com/product-info/reliability/>

†† Higher qualification ratings may be available should the user have such requirements. Please contact your International Rectifier sales representative for further information: <http://www.irf.com/whoto-call/salesrep/>

††† Applicable version of JEDEC standard at the time of product release.

**Notes:**

- ① Repetitive rating; pulse width limited by max. junction temperature.
- ② Starting  $T_J = 25^\circ\text{C}$ ,  $L = 0.21\text{mH}$ ,  $R_G = 50\Omega$ ,  $I_{AS} = 20\text{A}$ .
- ③ Pulse width  $\leq 400\mu\text{s}$ ; duty cycle  $\leq 2\%$ .
- ④  $R_\theta$  is measured at  $T_J$  of approximately  $90^\circ\text{C}$ .
- ⑤ When mounted on 1 inch square 2 oz copper pad on 1.5x1.5 in. board of FR-4 material. Please refer to AN-994 for more details: <http://www.irf.com/technical-info/appnotes/an-994.pdf>
- ⑥ Calculated continuous current based on maximum allowable junction temperature.
- ⑦ Current is limited to 25A by source bonding technology.
- ⑧ Pulse drain current is limited to 100A by source bonding technology.

**Revision History**

Date	Comments
6/5/2014	<ul style="list-style-type: none"> <li>• Updated schematic on page 1</li> <li>• Updated part marking on page 8</li> <li>• Updated tape and reel on page 9</li> </ul>
6/30/2014	<ul style="list-style-type: none"> <li>• Remove "SAWN" package outline on page 8.</li> </ul>
2/23/2016	<ul style="list-style-type: none"> <li>• Updated datasheet with corporate template</li> <li>• Updated package outline to reflect the PCN # (241-PCN30-Public) for "Option C" and "Option G" on page 8.</li> </ul>

**Published by**  
**Infineon Technologies AG**  
**81726 München, Germany**  
**© Infineon Technologies AG 2015**  
**All Rights Reserved.**

**IMPORTANT NOTICE**

The information given in this document shall in no event be regarded as a guarantee of conditions or characteristics ("Beschaffenheitsgarantie"). With respect to any examples, hints or any typical values stated herein and/or any information regarding the application of the product, Infineon Technologies hereby disclaims any and all warranties and liabilities of any kind, including without limitation warranties of non-infringement of intellectual property rights of any third party.

In addition, any information given in this document is subject to customer's compliance with its obligations stated in this document and any applicable legal requirements, norms and standards concerning customer's products and any use of the product of Infineon Technologies in customer's applications.

The data contained in this document is exclusively intended for technically trained staff. It is the responsibility of customer's technical departments to evaluate the suitability of the product for the intended application and the completeness of the product information given in this document with respect to such application.

For further information on the product, technology, delivery terms and conditions and prices please contact your nearest Infineon Technologies office ([www.infineon.com](http://www.infineon.com)).

**WARNINGS**

Due to technical requirements products may contain dangerous substances. For information on the types in question please contact your nearest Infineon Technologies office.

Except as otherwise explicitly approved by Infineon Technologies in a written document signed by authorized representatives of Infineon Technologies, Infineon Technologies' products may not be used in any applications where a failure of the product or any consequences of the use thereof can reasonably be expected to result in personal injury.

## Looking for pricing, stock, or lifecycle information?

Click below to explore more details on WIN SOURCE:

 [View IRFHM8235TRPBF on WIN SOURCE](#)

 [Infineon Technologies](#) Information

## Optimize Your Supply Chain with WIN SOURCE Solutions

-  Global Sourcing Solution
-  Obsolete Management
-  Cost Control Management
-  Shortage Management
-  Alternative Solution
-  Excess Inventory Management