



**THE DATASHEET OF  
H11G3SR2M**



# H11G1M, H11G2M, H11G3M High Voltage Photodarlington Optocouplers

## Features

- High  $BV_{CEO}$ 
  - Minimum 100V for H11G1M
  - Minimum 80V for H11G2M
  - Minimum 55V for H11G3M
- High sensitivity to low input current  
(Min. 500% CTR at  $I_F = 1\text{mA}$ )
- Low leakage current at elevated temperature  
(Max. 100 $\mu\text{A}$  at 80°C)
- Underwriters Laboratory (UL) recognized  
File # E90700, Volume 2
- IEC 60747-5-2 approved (ordering option V)

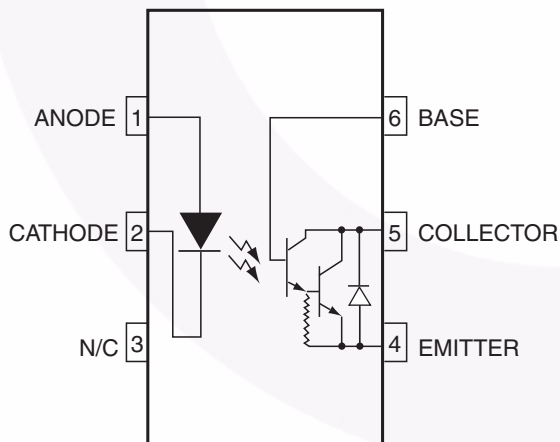
## Applications

- CMOS logic interface
- Telephone ring detector
- Low input TTL interface
- Power supply isolation
- Replace pulse transformer

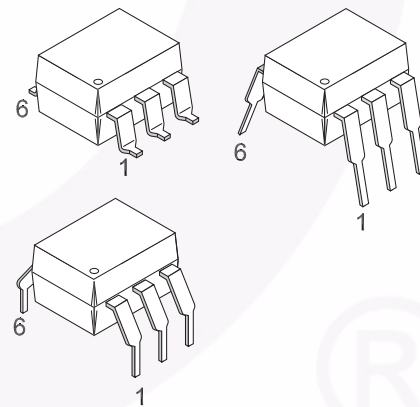
## General Description

The H11GXM series are photodarlington-type optically coupled optocouplers. These devices have a gallium arsenide infrared emitting diode coupled with a silicon darlington connected phototransistor which has an integral base-emitter resistor to optimize elevated temperature characteristics.

## Schematic



## Package Outlines



## Absolute Maximum Ratings

Stresses exceeding the absolute maximum ratings may damage the device. The device may not function or be operable above the recommended operating conditions and stressing the parts to these levels is not recommended. In addition, extended exposure to stresses above the recommended operating conditions may affect device reliability. The absolute maximum ratings are stress ratings only.

Symbol	Parameter	Value	Units
<b>TOTAL DEVICE</b>			
T <sub>STG</sub>	Storage Temperature	-40 to +150	°C
T <sub>OPR</sub>	Operating Temperature	-40 to +100	°C
T <sub>SOL</sub>	Lead Solder Temperature (Wave Solder)	260 for 10 sec	°C
P <sub>D</sub>	Total Device Power Dissipation @ T <sub>A</sub> = 25°C Derate Above 25°C	260	mW
		3.5	mW/°C
<b>EMITTER</b>			
I <sub>F</sub>	Forward Input Current	60	mA
V <sub>R</sub>	Reverse Input Voltage	6.0	V
I <sub>F(pk)</sub>	Forward Current – Peak (1µs pulse, 300pps)	3.0	A
P <sub>D</sub>	LED Power Dissipation @ T <sub>A</sub> = 25°C Derate Above 25°C	100	mW
		1.8	mW/°C
<b>DETECTOR</b>			
V <sub>CEO</sub>	Collector-Emitter Voltage H11G1M H11G2M H11G3M	100	V
		80	
		55	
P <sub>D</sub>	Photodetector Power Dissipation @ T <sub>A</sub> = 25°C Derate Above 25°C	200	mW
		2.67	mW/°C

**Electrical Characteristics** ( $T_A = 25^\circ\text{C}$  unless otherwise specified.)

**Individual Component Characteristics**

Symbol	Characteristic	Test Conditions	Device	Min.	Typ.*	Max.	Unit
<b>EMITTER</b>							
$V_F$	Forward Voltage	$I_F = 10\text{mA}$	All		1.3	1.50	V
$\frac{\Delta V_F}{\Delta T_A}$	Forward Voltage Temp. Coefficient		All		-1.8		mV/°C
$BV_R$	Reverse Breakdown Voltage	$I_R = 10\mu\text{A}$	All	3.0	25		V
$C_J$	Junction Capacitance	$V_F = 0\text{V}, f = 1\text{MHz}$	All		50		pF
		$V_F = 1\text{V}, f = 1\text{MHz}$			65		
$I_R$	Reverse Leakage Current	$V_R = 3.0\text{V}$	All		0.001	10	$\mu\text{A}$
<b>DETECTOR</b>							
$BV_{CEO}$	Breakdown Voltage Collector to Emitter	$I_C = 1.0\text{mA}, I_F = 0$	H11G1M	100			V
			H11G2M	80			
			H11G3M	55			
$BV_{CBO}$	Collector to Base	$I_C = 100\mu\text{A}$	H11G1M	100			V
			H11G2M	80			
			H11G3M	55			
$BV_{EBO}$	Emitter to Base		All	7	10		V
$I_{CEO}$	Leakage Current Collector to Emitter	$V_{CE} = 80\text{V}, I_F = 0$	H11G1M			100	nA
		$V_{CE} = 60\text{V}, I_F = 0$	H11G2M				
		$V_{CE} = 30\text{V}, I_F = 0$	H11G3M				
		$V_{CE} = 80\text{V}, I_F = 0, T_A = 80^\circ\text{C}$	H11G1M			100	$\mu\text{A}$
		$V_{CE} = 60\text{V}, I_F = 0, T_A = 80^\circ\text{C}$	H11G2M				

**Transfer Characteristics**

Symbol	Characteristics	Test Conditions	Device	Min.	Typ.*	Max.	Units
<b>EMITTER</b>							
CTR	Current Transfer Ratio, Collector to Emitter	$I_F = 10\text{mA}, V_{CE} = 1\text{V}$	H11G1M/2M	100 (1000)			mA (%)
		$I_F = 1\text{mA}, V_{CE} = 5\text{V}$	H11G1M/2M	5 (500)			
			H11G3M	2 (200)			
$V_{CE(SAT)}$	Saturation Voltage	$I_F = 16\text{mA}, I_C = 50\text{mA}$	H11G1M/2M		0.85	1.0	V
		$I_F = 1\text{mA}, I_C = 1\text{mA}$	H11G1M/2M		0.75	1.0	
		$I_F = 20\text{mA}, I_C = 50\text{mA}$	H11G3M		0.85	1.2	
<b>SWITCHING TIMES</b>							
$t_{ON}$	Turn-on Time	$R_L = 100\Omega, I_F = 10\text{mA}, V_{CE} = 5\text{V}, f \leq 30\text{Hz}, \text{Pulse Width} \leq 300\mu\text{s}$	All		5		$\mu\text{s}$
$t_{OFF}$	Turn-off Time		All		100		$\mu\text{s}$

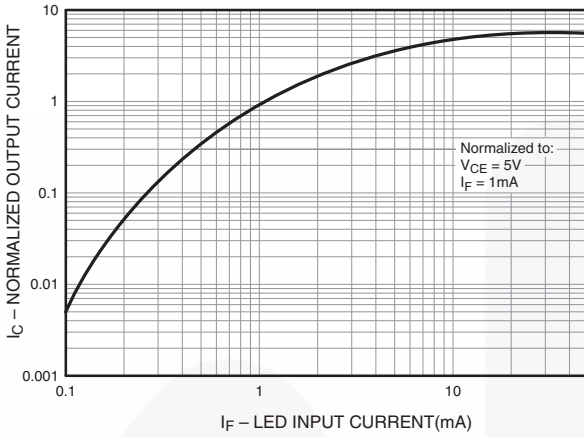
**Isolation Characteristics**

Symbol	Characteristic	Test Conditions	Device	Min.	Typ.*	Max.	Units
$V_{ISO}$	Isolation Voltage	$f = 60\text{Hz}, t = 1 \text{ sec.}$	All	7500			$V_{AC\text{PEAK}}$
$R_{ISO}$	Isolation Resistance	$V_{I-O} = 500 \text{ VDC}$	All	$10^{11}$			$\Omega$
$C_{ISO}$	Isolation Capacitance	$f = 1\text{MHz}$	All		0.2		pF

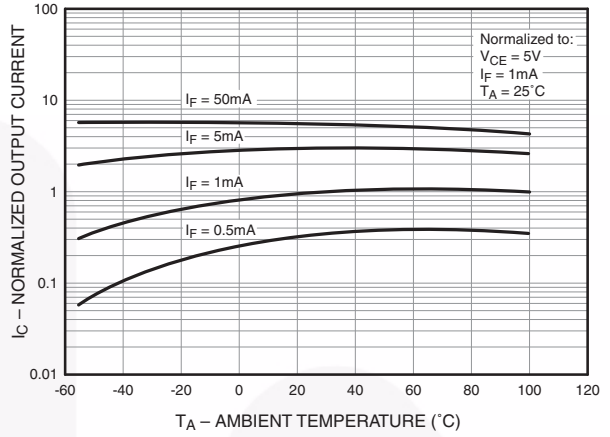
\*All Typical values at  $T_A = 25^\circ\text{C}$

## Typical Performance Curves

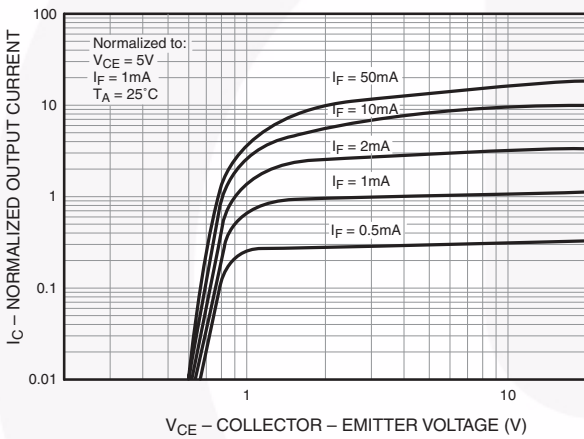
**Fig. 1 Output Current vs. Input Current**



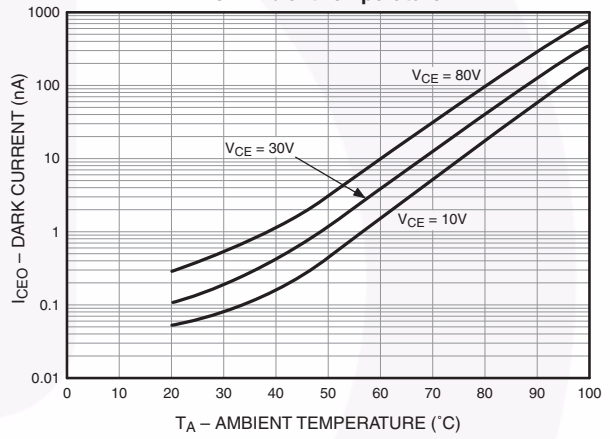
**Fig. 2 Normalized Output Current vs. Temperature**



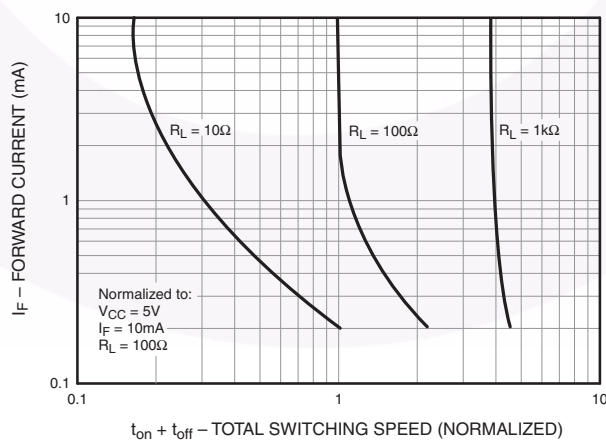
**Fig. 3 Output Current vs. Collector - Emitter Voltage**



**Fig. 4 Collector-Emitter Dark Current vs. Ambient Temperature**

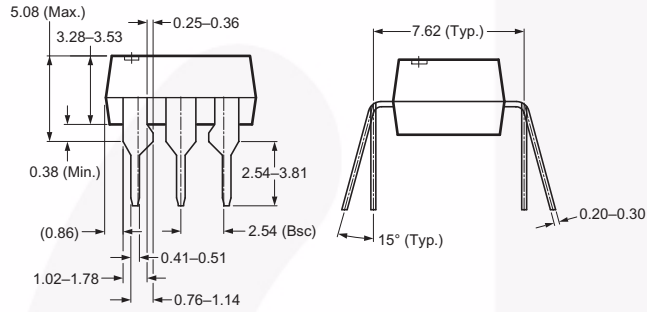
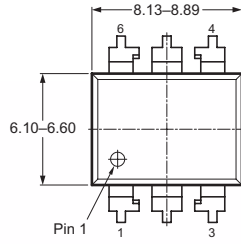


**Fig. 5 Input Current vs. Total Switching Speed (Typical Values)**

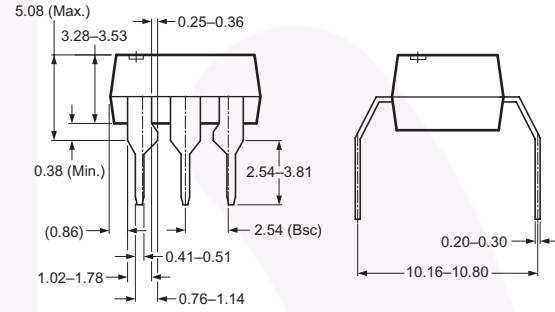
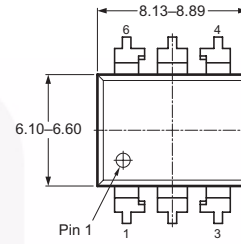


## Package Dimensions

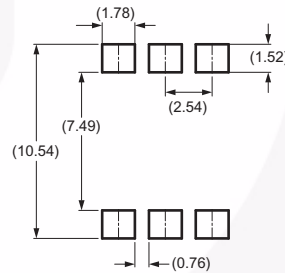
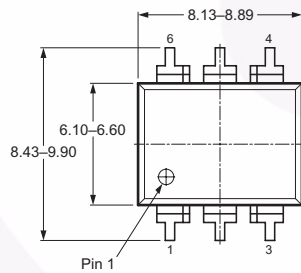
### Through Hole



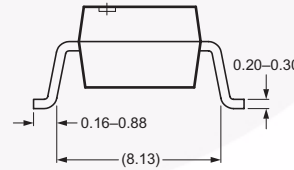
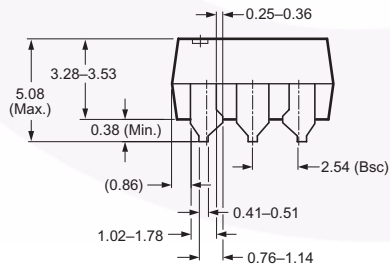
### 0.4" Lead Spacing



### Surface Mount



Recommended Pad Layout

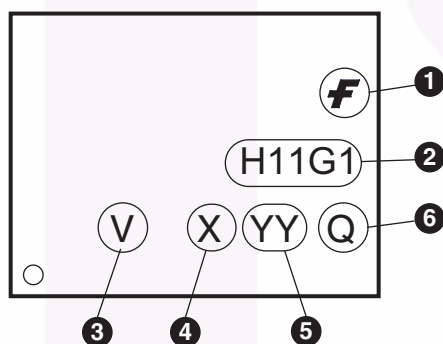


**Note:**  
All dimensions in mm.

## Ordering Information

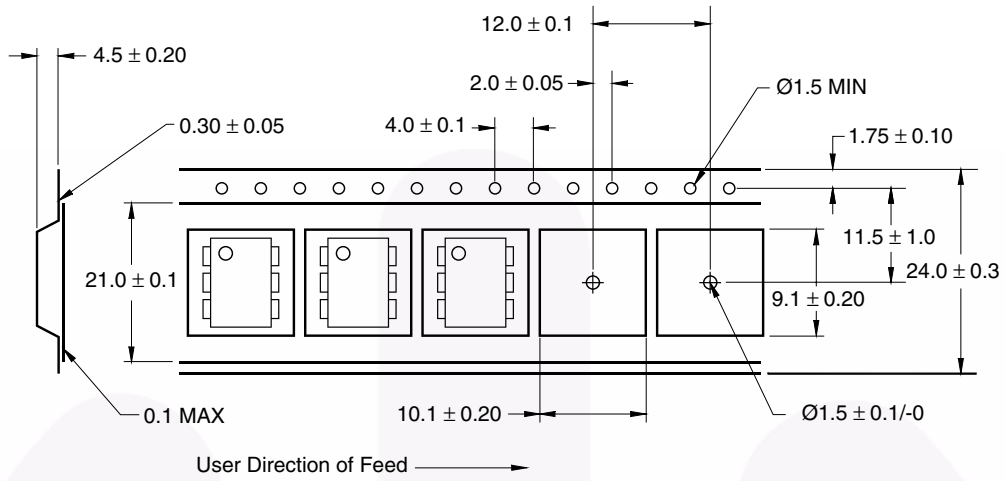
Option	Order Entry Identifier (Example)	Description
No option	H11G1M	Standard Through Hole Device
S	H11G1SM	Surface Mount Lead Bend
SR2	H11G1SR2M	Surface Mount; Tape and Reel
T	H11G1TM	0.4" Lead Spacing
V	H11G1VM	VDE 0884
TV	H11G1TVM	VDE 0884, 0.4" Lead Spacing
SV	H11G1SVM	VDE 0884, Surface Mount
SR2V	H11G1SR2VM	VDE 0884, Surface Mount, Tape and Reel

## Marking Information

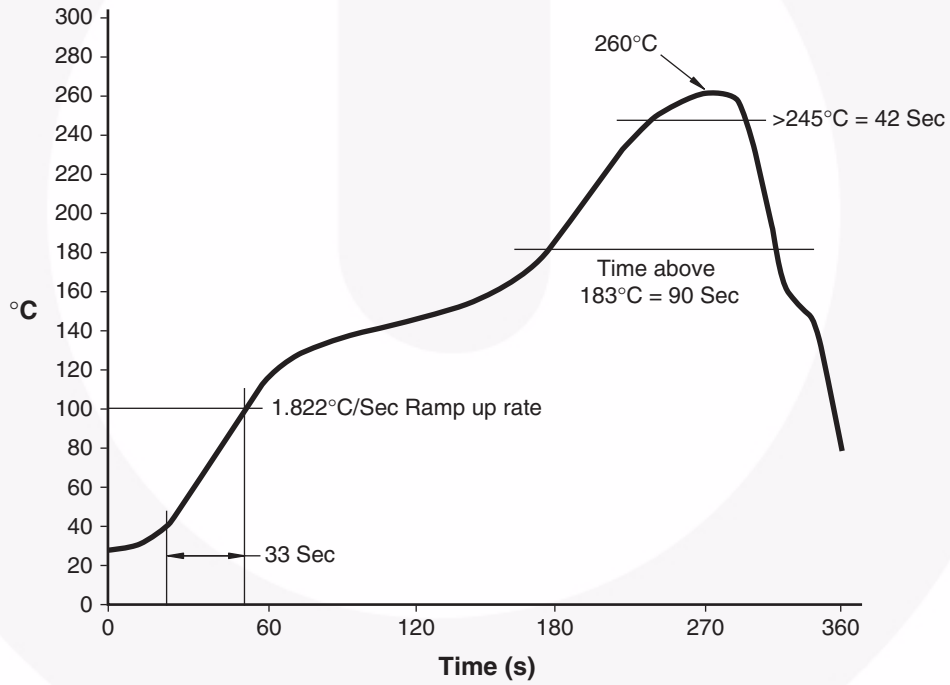


Definitions	
1	Fairchild logo
2	Device number
3	VDE mark (Note: Only appears on parts ordered with VDE option – See order entry table)
4	One digit year code, e.g., '7'
5	Two digit work week ranging from '01' to '53'
6	Assembly package code

### Carrier Tape Specification









### Reflow Profile





**TRADEMARKS**

The following includes registered and unregistered trademarks and service marks, owned by Fairchild Semiconductor and/or its global subsidiaries, and is not intended to be an exhaustive list of all such trademarks.

- |   |   |   |   |
|---|---|---|---|
| Build it Now™   | FRFET®  | Programmable Active Droop™  | the power franchise   |
| CorePLUS™   | Global Power Resource SM  | QFET®   | TinyBoost™  |
| CorePOWER™  | Green FPS™  | QS™   | TinyBuck™   |
| CROSSVOLT™  | Green FPS™ e-Series™  | Quiet Series™   | TinyLogic®  |
| CTL™  | GTO™  | RapidConfigure™   | TINYOPTO™   |
| Current Transfer Logic™   | IntelliMAX™   |  ™ | TinyPower™  |
| EcoSPARK®   | ISOPLANAR™  | Saving our world, 1mW/W/kW at a time™   | TinyPWM™  |
| EfficientMax™   | MegaBuck™   | SmartMax™   | TinyWire™   |
| EZSWITCH™ *   | MICROCOUPLER™   | SMART START™  | TriFault Detect™  |
|  ™ | MicroFET™   | SPM®  | µSerDes™  |
|  ™ | MicroPak™   | STEALTH™  |  ™ |
| Fairchild®  | MillerDrive™  | SuperFET™   | UHC®  |
| Fairchild Semiconductor®  | MotionMax™  | SuperSOT™-3   | Ultra FRFET™  |
| FACT Quiet Series™  | Motion-SPM™   | SuperSOT™-6   | UnifET™   |
| FACT®   | OPTOLOGIC®  | SuperSOT™-8   | VCX™  |
| FAST®   | OPTOPLANAR®   | SupreMOS™   | VisualMax™  |
| FastvCore™  |  ™ | SyncFET™  | XS™   |
| FlashWriter® *  | PDP SPM™  |  ™ |   |
| FPS™  | Power-SPM™  | The Power Franchise®  |   |
| F-PFS™  | PowerTrench®  |   |   |
|   | PowerXS™  |   |   |

\* EZSWITCH™ and FlashWriter® are trademarks of System General Corporation, used under license by Fairchild Semiconductor.

**DISCLAIMER**

FAIRCHILD SEMICONDUCTOR RESERVES THE RIGHT TO MAKE CHANGES WITHOUT FURTHER NOTICE TO ANY PRODUCTS HEREIN TO IMPROVE RELIABILITY, FUNCTION, OR DESIGN. FAIRCHILD DOES NOT ASSUME ANY LIABILITY ARISING OUT OF THE APPLICATION OR USE OF ANY PRODUCT OR CIRCUIT DESCRIBED HEREIN; NEITHER DOES IT CONVEY ANY LICENSE UNDER ITS PATENT RIGHTS, NOR THE RIGHTS OF OTHERS. THESE SPECIFICATIONS DO NOT EXPAND THE TERMS OF FAIRCHILD'S WORLDWIDE TERMS AND CONDITIONS, SPECIFICALLY THE WARRANTY THEREIN, WHICH COVERS THESE PRODUCTS.

**LIFE SUPPORT POLICY**

FAIRCHILD'S PRODUCTS ARE NOT AUTHORIZED FOR USE AS CRITICAL COMPONENTS IN LIFE SUPPORT DEVICES OR SYSTEMS WITHOUT THE EXPRESS WRITTEN APPROVAL OF FAIRCHILD SEMICONDUCTOR CORPORATION.

As used herein:

- Life support devices or systems are devices or systems which, (a) are intended for surgical implant into the body or (b) support or sustain life, and (c) whose failure to perform when properly used in accordance with instructions for use provided in the labeling, can be reasonably expected to result in a significant injury of the user.
- A critical component in any component of a life support, device, or system whose failure to perform can be reasonably expected to cause the failure of the life support device or system, or to affect its safety or effectiveness.

**ANTI-COUNTERFEITING POLICY**

Fairchild Semiconductor Corporation's Anti-Counterfeiting Policy. Fairchild's Anti-Counterfeiting Policy is also stated on our external website, [www.fairchildsemi.com](http://www.fairchildsemi.com), under Sales Support.

Counterfeiting of semiconductor parts is a growing problem in the industry. All manufacturers of semiconductor products are experiencing counterfeiting of their parts. Customers who inadvertently purchase counterfeit parts experience many problems such as loss of brand reputation, substandard performance, failed applications, and increased cost of production and manufacturing delays. Fairchild is taking strong measures to protect ourselves and our customers from the proliferation of counterfeit parts. Fairchild strongly encourages customers to purchase Fairchild parts either directly from Fairchild or from Authorized Fairchild Distributors who are listed by country on our web page cited above. Products customers buy either from Fairchild directly or from Authorized Fairchild Distributors are genuine parts, have full traceability, meet Fairchild's quality standards for handling and storage and provide access to Fairchild's full range of up-to-date technical and product information. Fairchild and our Authorized Distributors will stand behind all warranties and will appropriately address any warranty issues that may arise. Fairchild will not provide any warranty coverage or other assistance for parts bought from Unauthorized Sources. Fairchild is committed to combat this global problem and encourage our customers to do their part in stopping this practice by buying direct or from authorized distributors.

**PRODUCT STATUS DEFINITIONS**



**Definition of Terms**

Datasheet Identification	Product Status	Definition
Advance Information	Formative / In Design	Datasheet contains the design specifications for product development. Specifications may change in any manner without notice.
Preliminary	First Production	Datasheet contains preliminary data; supplementary data will be published at a later date. Fairchild Semiconductor reserves the right to make changes at any time without notice to improve design.
No Identification Needed	Full Production	Datasheet contains final specifications. Fairchild Semiconductor reserves the right to make changes at any time without notice to improve the design.
Obsolete	Not In Production	Datasheet contains specifications on a product that is discontinued by Fairchild Semiconductor. The datasheet is for reference information only.

Rev. 138

## Looking for pricing, stock, or lifecycle information?

Click below to explore more details on WIN SOURCE:

-  [View H11G3SR2M on WIN SOURCE](#)
-  [Fairchild/ON Semiconductor Information](#)

## Optimize Your Supply Chain with WIN SOURCE Solutions

-  Global Sourcing Solution
-  Obsolete Management
-  Cost Control Management
-  Shortage Management
-  Alternative Solution
-  Excess Inventory Management